

Uputstvo za upotrebu (EN)

SINCLAIR odvlaživač vazduha CFO20P



Tehnoteka je online destinacija za upoređivanje cena i karakteristika bele tehnike, potrošačke elektronike i IT uređaja kod trgovinskih lanaca i internet prodavnica u Srbiji. Naša stranica vam omogućava da istražite najnovije informacije, detaljne karakteristike i konkurentne cene proizvoda.

Posetite nas i uživajte u ekskluzivnom iskustvu pametne kupovine klikom na link:

<https://tehnoteka.rs/p/sinclair-odvlazivac-vazduha-cfo20p-akcija-cena/>

USER MANUAL

DEHUMIDIFIERS

CFO-20P, CFO-40P



Content

Operation Notices

- The Refrigerant..... 1
- Safety Precautions.....2
- Operation Area.....3
- Parts Name.....4
- Check Before Operation.....5

Operation Instructions

- Operation Method.....6
- Drainage Method9

Maintenance

- Clean and Maintenance.....12

Malfunction

- Troubleshooting.....15
- Error Codes, Technical specifications.....17
- Electric schematic diagram19
- Producer, service, contact 20

Note:

Graphics in this manual are only for reference. Please refer to actual products for specific details.

This appliance is not intended for use by persons (including children) with reduced physical, sensory or mental capabilities, or lack of experience and knowledge, unless they have been given supervision or instruction concerning use of the appliance by a person responsible for their safety. Children should be supervised to ensure that they do not play with the appliance.



This marking indicates that this product should not be disposed with other household wastes throughout the EU. To prevent possible harm to the environment or human health from uncontrolled waste disposal, recycle it responsibly to promote the sustainable reuse of material resources. To return your used device, please use the return and collection systems or contact the retailer where the product was purchased. They can take this product for environmental safe recycling.

Explanation of Symbols



DANGER

Indicates a hazardous situation that, if not avoided, will result in death or serious injury.



WARNING

Indicates a hazardous situation that, if not avoided, could result in death or serious injury.



CAUTION

Indicates a hazardous situation that, if not avoided, may result in minor or moderate injury.

NOTICE

Indicates important but not hazard-related information, used to indicate risk of property damage.



Indicates a hazard that would be assigned a signal word **WARNING** or **CAUTION**.

Exception Clauses

Manufacturer will bear no responsibilities when personal injury or property loss is caused by the following reasons.

1. Damage the product due to improper use or misuse of the product;
2. Alter, change, maintain or use the product with other equipment without abiding by the instruction manual of manufacturer;
3. After verification, the defect of product is directly caused by corrosive gas;
4. After verification, defects are due to improper operation during transportation of product;
5. Operate, repair, maintain the unit without abiding by instruction manual or related regulations;
6. After verification, the problem or dispute is caused by the quality specification or performance of parts and components that produced by other manufacturers;
7. The damage is caused by natural calamities, bad using environment or force majeure.



Appliance filled with flammable gas R290.



Before install and use the appliance, read the owner's manual first.



Before install the appliance, read the installation manual first.



Before repair the appliance, read the service manual first.

The Refrigerant

- To realize the function of the air conditioner unit, a special refrigerant circulates in the system. The used refrigerant is the fluoride R290, which is specially cleaned. The refrigerant is flammable and inodorous. Furthermore, it can lead to explosion under certain conditions.
- Compared to common refrigerants, R290 is a nonpolluting refrigerant with no harm to the ozone layer. The influence upon the greenhouse effect is also lower. R290 has very good thermodynamic features which lead to a really high energy efficiency. The units therefore need a less filling.
- Please refer to the nameplate for the charging quantity of R290.

WARNING :

- Appliance filled with flammable gas R290.
- Appliance shall be installed, operated and stored in a room with a floor area larger than 4 m².
- The appliance shall be stored in a room without continuously operating ignition sources . (for example: open flames, an operating gas appliance or an operating electric heater.)
- The appliance shall be stored in a well-ventilated area where the room size corresponds to the room area as specified for operation.
- The appliance shall be stored so as to prevent mechanical damage from occurring.
- Keep any required ventilation openings clear of obstruction.
- Do not pierce or burn.
- Be aware that refrigerants may not contain an odour.
- Do not use means to accelerate the defrosting process or to clean, other than those recommended by the manufacturer.
- Servicing shall be performed only as recommended by the manufacturer.
- Should repair be necessary, contact your nearest authorized Service Centre. Any repairs carried out by unqualified personnel may be dangerous.
- Compliance with national gas regulations shall be observed.
- Read specialist's manual.

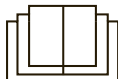

Safety Precautions

- This appliance can be used by children aged from 8 years and above and persons with reduced physical, sensory or mental capabilities or lack of experience and knowledge if they have been given supervision or instruction concerning use of the appliance in a safe way and understand the hazards involved.
- Children shall not play with the appliance.
- Cleaning and user maintenance shall not be made by children without supervision.
- Before operation, please check the power cord if it complies with the requirement indicated on the nameplate.
- Before cleaning, please turn it off and unplug the dehumidifier.
- Make sure the power cord is not pressed by any hard objects.
- Do not remove the power plug or move unit by pulling the power cord.
- Do not operate any heating appliances near the dehumidifier.
- Do not move get the power plug with wet hands.
- Please use grounded power cord and make sure it's well connected and not damaged.
- Children and disabled people are not allowed to use the dehumidifier without supervision.
- Keep children from playing or climbing on the dehumidifier.
- Memory function is included in this dehumidifier. When nobody is taking care of the unit, please turn it off and remove the power plug or disconnect power.
- Do not repair or disassemble the unit by yourself.
- If abnormal condition occurs (e.g. burned smell), please disconnect power at once and then contact local dealer.
- Dehumidifier can not be disposed of everywhere. If you want to get rid of this dehumidifier, please check with local handling disposal or information service center about what to do.
- Do not use an extension cord.
- The appliance shall be installed in accordance with national wiring regulations.
- If the SUPPLY CORD is damaged, it must be replaced by the manufacturer, its service agent or similarly qualified person in order to avoid a hazard.
- Prohibit operating the unit in the bathroom or laundry room.
- Far away from fire source, inflammable and explosive objects.

Operation Area

- This dehumidifier is intended for indoor applications only. It should not be used for commercial or industrial applications.
- Place the dehumidifier on a smooth and level floor.
- During operation, the nearby enclosed space, such as wardrobe can't be dehumidified.
- Place the dehumidifier in an area where the temperature will not below 5°C or above 32°C. The suggested range of relative humidity is between 30% and 90%.
- During operation, please make sure there's enough space around the unit.
- Close all doors, windows and other outside openings of the room to improve the working effect.
- Please keep the air inlet/outlet clean and not blocked.
- Avoid direct sunlight.

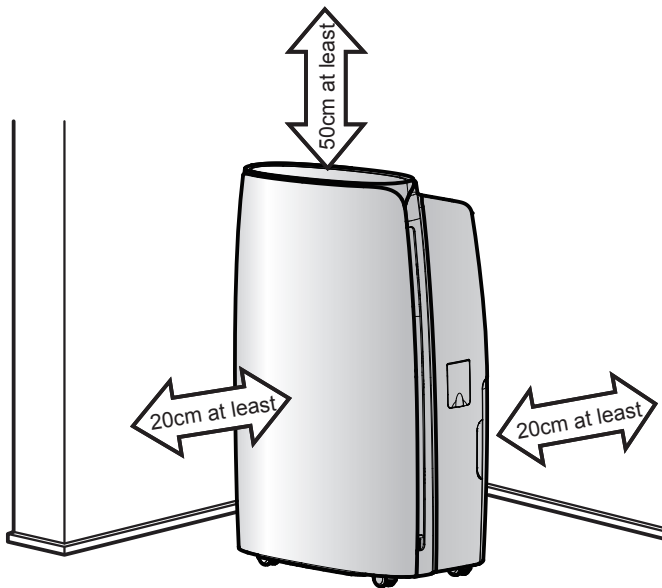

Note:

- The dehumidifier has rollers to aid placement. Do not attempt to roll the dehumidifier on carpet or over objects. Otherwise, water may spill out from the bucket or the dehumidifier may get stuck by the objects.
- Please stop operation before moving the dehumidifier. The tilting angle can't be too large when moving the unit. Do not move the unit along front or back direction.

Parts Name

Front Side

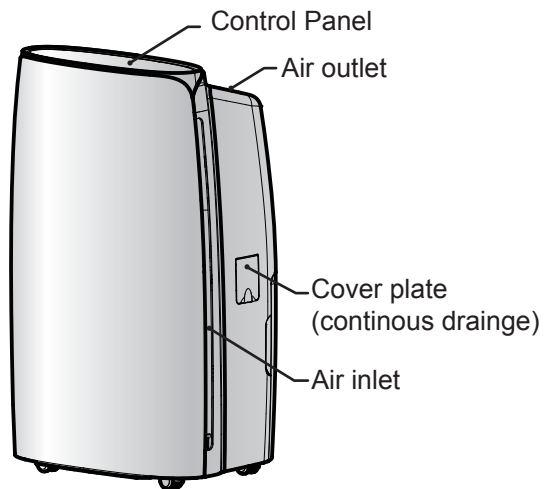

Back Side

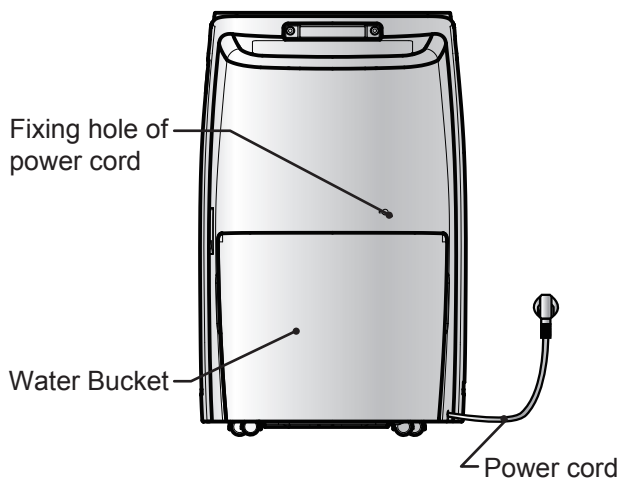

Check Before Operation

Before operation, please first check whether float is properly placed.

Below are the checking steps:

1. Hold the handles on both sides of the water bucket and pull it out following the arrow direction.

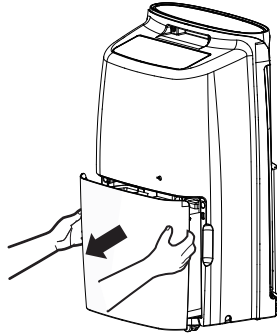

2. Check whether float in the water bucket is properly placed. It might have been moved a little after long-time transportation. If it's not placed properly, move it to the correct position by hand.

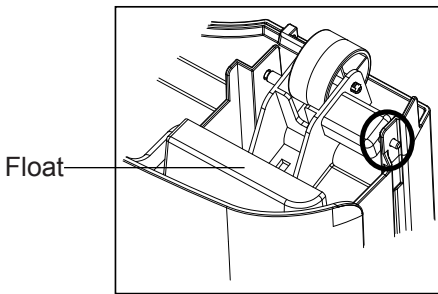

Correct Position

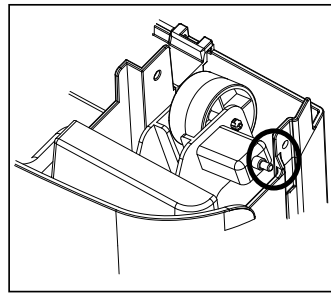

Wrong Position

3. Replace the bucket as instructed in step 1.

Operation Method

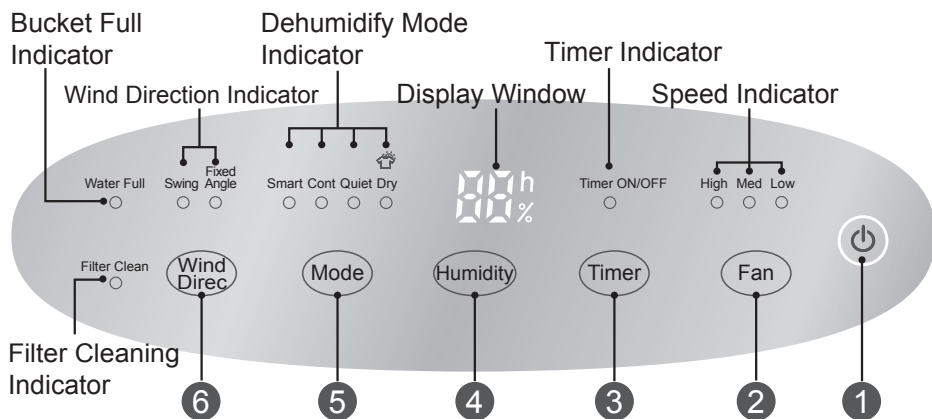

Notes:

- Water bucket must be correctly installed for operation.
- Do not remove the bucket while unit is in operation.
- If you want to use drain hose to drain water away, please install the hose according to section "Drainage method".
- Each time pressing the effective button on the control panel will give out a "beep" sound.
- When power is connected, power indicator on the control panel will be on and dehumidifier gives out a "beep" sound simultaneously.

Basic Functions of the Buttons

- 1** ON/OFF Button
Press this button to turn on/off dehumidifier.
- 2** Fan Button
Press Fan button can set high, medium or low fan speed. When the corresponding indicator is on, it indicates the current fan speed has been set.
- 3** Timer Button
Press Timer button to set timer on or timer off. The timer can be set in 1h increment among 0-24h with each press of Timer button. If hold the Timer button, time will increase rapidly circularly. After timer is set, time will be displayed for 5s and timer indicator will be on.

4 Humidity Button

Press Humidity button to set your required humidity. If hold Humidity button, humidity can be set in 10% increment among 30%-80% circularly. After that, the set humidity will be displayed for 5s.

5 Mode Button

Press Mode button can set 4 kinds of dehumidify mode - Smart, Cont., Quiet and Dry.

- If smart indicator is on, it indicates the unit enters into smart mode. The unit will intelligently select the comfortable humidity for human according to current temperature.
- If cont indicator is on, it indicates the unit enter into continuous dehumidify mode. The unit will always dehumidify only until the humidity is decreased to the inapplicable humidity of human.
- If the quiet indicator is on, the unit enter into quiet mode. The unit will intelligently select the comfortable humidity for human according to current temperature. The unit will operate at the fan speed whose noise is the lowest. The fan speed can't be adjusted.
- If the dry indicator is on, the unit enters into dry mode. After clothes are dried, room humidity will be kept at certain range to prevent mildew. Under dry mode, fan speed and humidity can't be adjusted.

Note:

- Under smart mode and quiet mode, if room humidity is lower than set humidity, or lower than the defaulted comfortable temperature, the unit will stop dehumidifying.
- Under dry mode and cont mode, the humidity can't be adjusted. Under dry mode and quiet mode, fan speed can't be adjusted.

6 Wind Direc Button

When swing of horizontal louver is needed, press Wind Direc button to select swing or fixed angle. When Swing light of Wind Direc indicator is on, the horizontal louver begins to swing; when Fixed Angle light is on, the horizontal louver stays at current position.

Other Instructions

1. Alarm Warning

If the water bucket is full or the water bucket hasn't been put on the correct position for 3mins, the buzzer will give out sound for 10s for reminding you to empty the water bucket or re-install the water bucket at correct position.

2. Auto Stop

When bucket is full, remove the unit or not placed the unit correctly or the humidity is 10% lower than the set humidity, the unit will stop operation automatically.

3. Memory Function

If power failure, all settings will be memorized. After power recovery, the unit will resume operate according to the memorized settings.

4. Bucket full light

This indicates that bucket is full or removed or not placed correctly.

5. Filter reset

When the indicator of filter clean is on, it needs to clean filter. After filter is cleaned, press Fan button and Humidity button simultaneously and then the indicator of filter clean will be off.

6. Child lock function

Press Mode button and Timer button simultaneously for 1s to enter into child lock protection. After pressing any button, LC will be displayed to indicate buttons are locked. Press Mode button and Timer button simultaneously for 1s again to release shielding function.

Drainage Method

Method 1: Drain water through water bucket

Notes:

- Do not remove the bucket when unit is in operation or has just stopped. Otherwise it may cause some water to drip on the floor.
 - Do not use the hose if using water bucket to collect water. When the hose is connected, water will be drained out through it instead of into the bucket.
1. Hold the handles on both sides of the water bucket and pull it out following the arrow direction. (Attention: Pull out the bucket carefully in case the water may spill out from the bucket and onto the floor.)

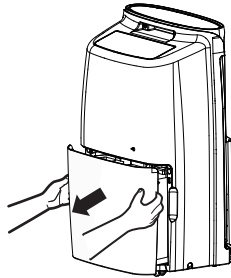

2. Pour out the water.

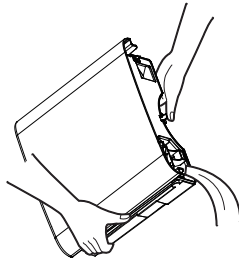

3. Replace bucket in the dehumidifier according to the arrow direction.

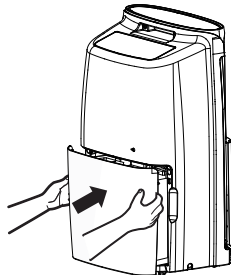

Method 2: Drain water through drain hose

This unit is connect with drain outlet. User can purchase the drain hose whose inner diameter is 14mm (length is 1.3-1.5m) and assemble it on the drain adapter to drain condensate water. When assembling the continuous drain equipment, do turn off the unit and pull out the power plug.

1. Open continuous drain outlet and then remove the drain cover along the arrow direction as shown in below arrow.

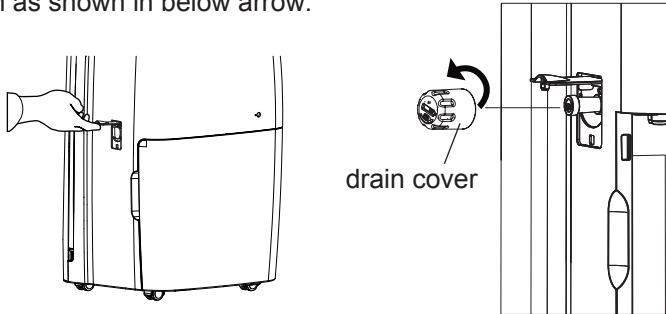

Note:

When using the water bucket to drain water, please re-assemble the drain cover and the drainage choke plug. Otherwise, leakage may occur when using water bucket to drain water.

2. Remove the drainage choke plug at first, rotate the drainage adapter into the continuous drain outlet in clockwise direction.
Pull the drainage adapter through the continuous drain outlet, and then rotate it into the drain outlet of the unit tightly. Please check whether the gasket is in good condition.

Note:

After removing the drainage choke plug, there will be a little residual condensate water. Please use container to collecting it to prevent moistening the floor.

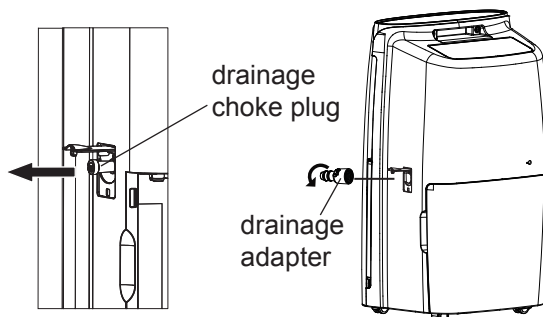

3. Insert the drain hose into drainage adapter to make sure the water won't leak out. The horizontal height of drain hose should not be higher than the drain outlet. Do not block the drain outlet to make the condensate water can be drained out smoothly. Please check drainage adapter and drain hose periodically to see whether they are connected tightly and whether they are damaged or blocked.

Note:

Please make sure the drain hose is put along the direction of drain out of water bucket. Insert one end of drain hose into the floor drain and then cover the lid of floor drain. Please do not press and flatten the drain hose.

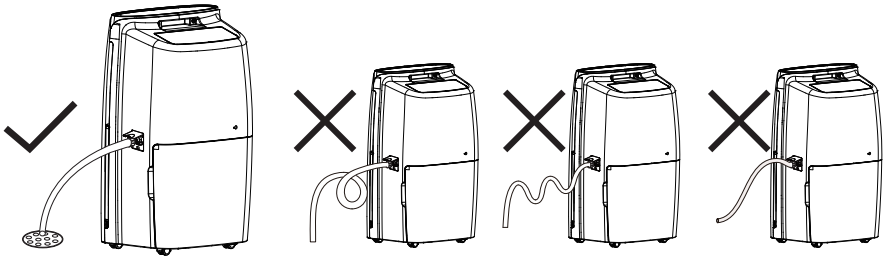

Clean and Maintenance

Warning:

- Before cleaning, turn off the dehumidifier and disconnect the power. Otherwise, it may lead to electric shock.
- Do not wash the dehumidifier with water, or it may lead to electric shock.
- Do not use volatile liquid (such as thinner or gasoline) to clean dehumidifier. Otherwise it will damage unit's appearance.

1. Grille and Case

To clean the case:

When there is dust on the case, use soft towel to dust it off; When the case is very dirty (greasy), use mild detergent to clean it.

To clean the grille: Use a dust catcher or brush.

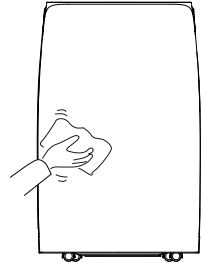

2. Air Filter

1. Remove panel

Open the clasps at both sides of lower side of panel, open the panel as shown in fig ①, and open it to 20°. Do not open it forcibly or open the angle too large. As shown in fig ②, pull up the panel to remove it.

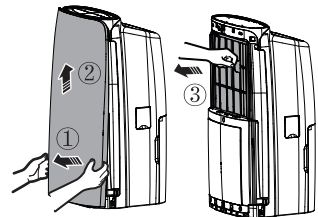

2. Remove air filter

As shown in fig ③, pull the clasps of air filter outwards to remove the air filter.

3. Clean air filter

Clean the filter in warm, soapy water. Rinse it and let the filter dry before replacing it.

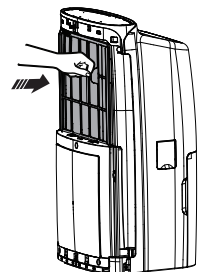

4. Install air filter

Insert the clasp at lower part of air filter into the unit and then press the air filter downwards until you have heard a sound. After that, re-assemble the panel.

Warning:

- Do not operate the dehumidifier without a filter. Otherwise the evaporator will catch dust and affect unit's performance.
- Do not dry the air filter with fire or electric hair dryer. Otherwise the air filter may be unshaped or caught on fire.
- Don't use dust catcher or brush to clean the air filter. Otherwise the air filter may be destroyed.

3. Water Bucket

Every few weeks, clean the bucket to prevent growth of mold, mildew and bacteria. Use soft brush to clean the bucket and then rinse it.

CFO-20P

1. Take out the water bucket and then pour out the residual water.
2. Press down 4 buckles around the water bucket. Lift up the drain lid.

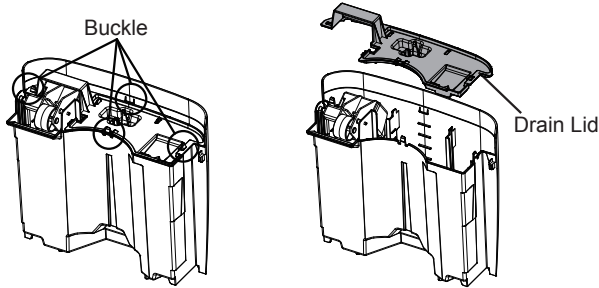

3. After cleaning, replace the drain lid and make sure the float of water bucket is placed properly. The side with foam plastic should be beneath the drain lid. Do not remove the foam plastic on the float.

CFO-40P

1. Take out the water bucket and then pour out the residual water.
2. As shown in the figure, rotate the handle to make it out from the shaft hole and then remove the handle. Open the four clasps on water tank cover and then remove the cover.

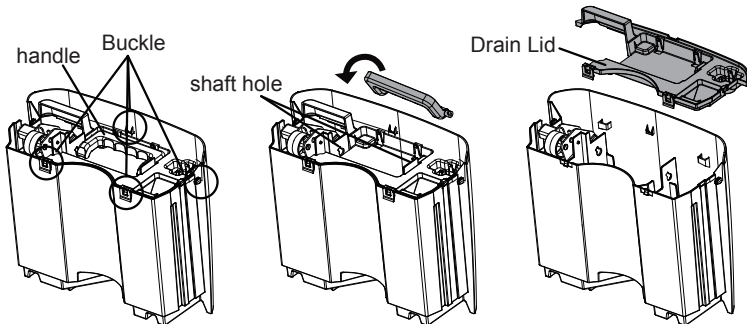

3. After cleaning, replace the drain lid and handle, and make sure the float of water bucket is placed properly. The side with foam plastic should be beneath the drain lid. Do not remove the foam plastic on the float.

Check Before Use-season

- Check whether air outlet is blocked.
- Check whether power plug and power socket are in good condition.
- Check whether air filter is clean.
- Check whether drain hose is damaged.

Care After Use-season

- Disconnect power.
- Clean air filter and case.
- Clean dust and obstacle of the dehumidifier.
- Empty the water bucket.

Long-time Storage

If you won't use the dehumidifier for a long time, we suggest that you follow the steps below in order to maintain the unit in good condition.

- Make sure the water inside the water bucket is poured out and then drain hose is removed.
- Unplug the dehumidifier and pack the power cord.
- Clean the unit and then wrap it well for preventing dust.

Troubleshooting

- Not all the following problems are malfunctions.

Problem	Possible Causes
Dehumidifier is not operating. Controls can not be set.	<ul style="list-style-type: none"> ● Unit is operating in an area where temperature is higher than 32°C or lower than 5°C. ● Bucket is full.
Noise suddenly rises during operation.	<ul style="list-style-type: none"> ● Noise will rise if compressor has just started. ● Power supply problem. ● Unit is placed on uneven floor.
Humidity does not drop.	<ul style="list-style-type: none"> ● Area to be dehumidified is too large. The capacity of your dehumidifier may not be adequate. ● Doors are open. ● There might be some device producing vapor in the room.
Little or no effect in dehumidifying	<ul style="list-style-type: none"> ● Room temperature is too low. ● Humidity level may be improperly set. ● If unit is operating in a room where temperature is from 5 to 15 °C, it will start to defrost automatically. Compressor will stop for a brief period of time(fan will operate in high fan speed). When unit finishes defrosting, it will be back to normal operation.
When first operated, the air emitted has musty-odor.	<ul style="list-style-type: none"> ● Due to temperature rising of heat exchanger, the air may have some strange smell at the beginning.
Unit has noises.	<ul style="list-style-type: none"> ● There might be some noise if unit is operating on wooden floor.
Swooshing sound is heard.	<ul style="list-style-type: none"> ● Normal. This is the sound of the flow of refrigerant.

- Problem of water leakage

Problem	Possible Causes	Solution
When using drain hose, there is water in the bucket.	<ul style="list-style-type: none"> ● Examine the drainage joint. 	<ul style="list-style-type: none"> ● Connect the drainage joint well.
	<ul style="list-style-type: none"> ● Drain hose is not correctly installed. 	<ul style="list-style-type: none"> ● Clear the obstacle from the drain hose.
	<ul style="list-style-type: none"> ● Drain hose is not correctly installed. 	<ul style="list-style-type: none"> ● Remove the drain hose and replace it. Be sure that the hose is correctly installed.

● Dehumidifier can't be started up.

Problem	Possible Causes	Solution
Power indicator is not lit when power is connected.	<ul style="list-style-type: none"> ● Power is not supplied for the dehumidifier or the power plug is not well inserted. 	<ul style="list-style-type: none"> ● Check if power is lost. If yes, wait for the power to restore. ● If not, check whether the power circuit or power socket has been damaged. ● Check whether power plug is loosen. ● Check whether power cord is damaged.
	<ul style="list-style-type: none"> ● Fuse is blown. 	<ul style="list-style-type: none"> ● Replace the fuse.
Bucket full indicator is lit up.	<ul style="list-style-type: none"> ● Bucket is not properly placed. ● Water is full in the bucket. ● Bucket has been removed. 	<ul style="list-style-type: none"> ● Empty the bucket and replace it.
Unit can function normally but it can not start up.	<ul style="list-style-type: none"> ● Humidity is set too high. 	<ul style="list-style-type: none"> ● If you want the air drier, press - button to lower the figure or press CO button for unit to dehumidify continuously.

● Dehumidifier does not dry air as intended.

Bad dehumidifying performance	<ul style="list-style-type: none"> ● Check whether there is any obstacle around the unit. 	<ul style="list-style-type: none"> ● Make sure there is no curtain, shutter or furniture that blocks the dehumidifier.
	<ul style="list-style-type: none"> ● Air filter is dusty and blocked. 	<ul style="list-style-type: none"> ● Clean the filter.
	<ul style="list-style-type: none"> ● Doors and windows are left open. 	<ul style="list-style-type: none"> ● Make sure all doors and windows and other opening to the outside have been closed.
	<ul style="list-style-type: none"> ● Room temperature is too low. 	<ul style="list-style-type: none"> ● Warm temperature is good for dehumidification. Low temperature will reduce unit's working effect. This unit should be working in a place where temperature is above 5°C.

Error Codes

● Unit's Malfunction Codes

No.	Malfunction Name	Display Code	Unit's Condition	Possible Causes
		Display Window		
1	Ambient Temperature Sensor Malfunction	F1	Compressor and fan motor stop. Buttons are invalid.	<ul style="list-style-type: none"> ● Ambient temperature sensor is loosen or is poorly connected with the terminal of display board.
				<ul style="list-style-type: none"> ● Some element of display board may have been put upside down and cause short circuit.
				<ul style="list-style-type: none"> ● Ambient temperature sensor is damaged(Please refer to Checking Table for Temperature Sensor Resistance).
2	Tube Temperature Sensor Malfunction	F2		<ul style="list-style-type: none"> ● Display board is damaged.
				<ul style="list-style-type: none"> ● Temperature sensor on the evaporator is loosen or is poorly connected with the terminal of display board.
				<ul style="list-style-type: none"> ● Some element of display board may have been put upside down and cause short circuit.
				<ul style="list-style-type: none"> ● Temperature sensor on the evaporator is damaged(Please refer to Checking Table for Temperature Sensor Resistance).
3	Humidity Sensor Malfunction	L1		<ul style="list-style-type: none"> ● Display board is damaged.
				<ul style="list-style-type: none"> ● Humidity sensor is short-circuited. ● Humidity sensor is damaged. ● Display board is damaged.

No.	Malfunction Name	Display Code	Unit's Condition	Possible Causes
		Display Window		
4	Freon-lacking protection	F0	The compressor stops. Buttons are invalid.	<ul style="list-style-type: none"> ● Refrigerant is leaking. ● System is blocked.
5	Overload protection	H3	The compressor stops and fan motor keeps on running. Buttons are invalid.	<ul style="list-style-type: none"> ● Ambient operation condition is bad. ● The evaporator and condenser are blocked with filth. ● The system is abnormal.
6	Overcurrent protection	E5		<ul style="list-style-type: none"> ● Relay is short-circuited or broken-circuited; ● Operation environment condition is formidable high temperature and high humidity.

Model	CFO-20P	CFO-40P
Rated voltage	220-240 V~	
Rated frequency	50 Hz	
Power input	360 W (max. 450 W)	670 W (max. 900 W)
Dehumidifying (temper. 30°C a RH 80%)	20 l / day	40 l / day
Operating temperature	5 - 32 °C	
Refrigerant (charge)	R290 (0,11kg)	R290 (0,15kg)
Sound pressure level	max. 43 dB(A)	max. 48 dB(A)
Weight netto / bruto	15,5 / 17,0 kg	22,5 / 24,5 kg
Water tank volume	3,5 l	6,5 l

Electric schematic diagram

The Electric schematic diagram are subject to change without notice. Please refer to which one on the unit.

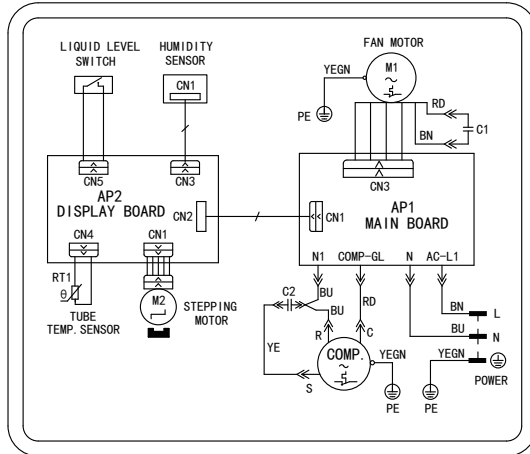

Producer, service, contact

Producer:

SINCLAIR CORPORATION Ltd., 1-4 Argyll St., London, UK

The device was made in China.

Service, authorised representative, contact:

SINCLAIR Global Group s.r.o.

Purky ova 45

Brno

612 00

Czech republic

Tel.: +420 541 590 140

Fax: +420 541 590 124

info@sinclair-solutions.com

www.sinclair-solutions.com



Ovaj dokument je originalno proizveden i objavljen od strane proizvođača, brenda Sinclair, i preuzet je sa njihove zvanične stranice. S obzirom na ovu činjenicu, Tehnoteka ističe da ne preuzima odgovornost za tačnost, celovitost ili pouzdanost informacija, podataka, mišljenja, saveta ili izjava sadržanih u ovom dokumentu.

Napominjemo da Tehnoteka nema ovlašćenje da izvrši bilo kakve izmene ili dopune na ovom dokumentu, stoga nismo odgovorni za eventualne greške, propuste ili netačnosti koje se mogu naći unutar njega. Tehnoteka ne odgovara za štetu nanесenu korisnicima pri upotrebi netačnih podataka. Ukoliko imate dodatna pitanja o proizvodu, ljubazno vas molimo da kontaktirate direktno proizvođača kako biste dobili sve detaljne informacije.

Za najnovije informacije o ceni, dostupnim akcijama i tehničkim karakteristikama proizvoda koji se pominje u ovom dokumentu, molimo posetite našu stranicu klikom na sledeći link:

<https://tehnoteka.rs/p/sinclair-odvlazivac-vazduha-cfo20p-akcija-cena/>