

## Uputstvo za upotrebu

PHILIPS ručni mikser HR3739/00

# PHILIPS



Tehnoteka je online destinacija za upoređivanje cena i karakteristika bele tehnike, potrošačke elektronike i IT uređaja kod trgovinskih lanaca i internet prodavnica u Srbiji. Naša stranica vam omogućava da istražite najnovije informacije, detaljne karakteristike i konkurentne cene proizvoda.

Posetite nas i uživajte u ekskluzivnom iskustvu pametne kupovine klikom na link:

<https://tehnoteka.rs/p/philips-rucni-mikser-hr373900-akcija-cena/>

**PHILIPS**

HR3739



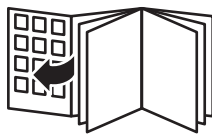





English 6  
Čeština 10  
Dansk 14  
Deutsch 18  
Eesti 22  
Español 26  
Français 30  
Hrvatski 34  
Italiano 38  
Latviešu 42  
Lietuviškai 46  
Magyar 50  
Nederlands 54  
Norsk 58  
Polski 62  
Português 66  
Română 70  
Shqip 74  
Slovenščina 78  
Slovensky 82  
Srpski 86  
Suomi 90  
Svenska 94  
Türkçe 98  
Ελληνικά 102  
Български 106  
Македонски 110  
Русский 114  
Українська 118  
Қазақша 122  
עברית 126

# Introduction

Congratulations on your purchase and welcome to Philips!

To fully benefit from the support that Philips offers, register your product at [www.philips.com/welcome](http://www.philips.com/welcome).

## General description

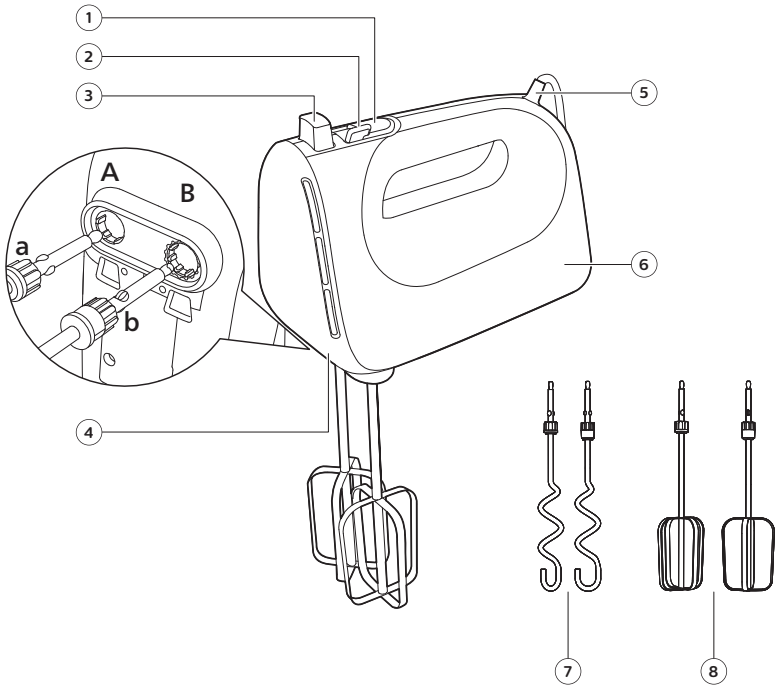

- 1 Turbo button  
Press and hold to reach the maximum speed
- 2 Speed control  
0: OFF position  
1-5: speed setting
- 3 Eject button  
Press to release the beaters or dough hooks
- 4 Hole for the beaters and dough hooks
- 5 Power cord
- 6 Main unit
- 7 Two dough hooks
- 8 Two beaters

## Before first use

Before the first use, wash the appliance and accessories with warm soapy water. Rinse them thoroughly and dry them completely before assembling. Avoid placing it near heat sources, water, or flammable materials.

## Using the appliance

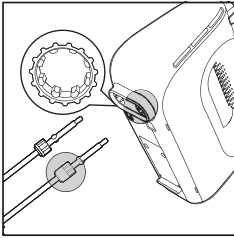

- 1 Insert the beaters or kneading hooks into the main unit.

**Insert the beater or kneading hook with the plastic collar into the larger opening.**

- 2 Put the plug in the wall socket.
- 3 Put the ingredients in a bowl.

**See the recommended quantities and processing times in the section "Processing quantities and processing time".**

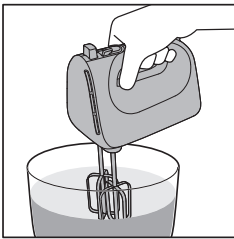

- 4 Lower the beaters or kneading hooks into the ingredients.

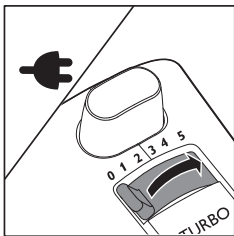

- 5 Set the speed control to the desired speed setting to switch on the appliance.

**Start mixing at a low speed to avoid splashing. Switch to a higher speed later.**

You can press the turbo button to mix more quickly or increase the speed during heavy tasks, e.g., kneading yeast dough.

If you want to stop mixing for a while, set the speed control to '0' to switch off the appliance.

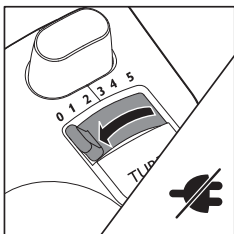

- 6 When you have finished mixing, set the speed control to '0' and unplug the appliance.



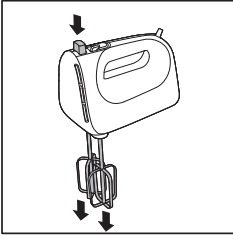









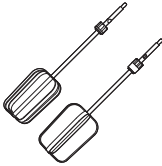

7 To release the beaters or kneading hooks, press the eject button.

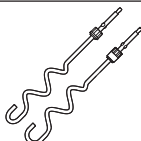
## Processing quantities and processing time

**Do not exceed the maximum quantities and processing times indicated.**











		 Kg (MAX)		
		500 ml	6 min	5
		8 x 	2 min	5
		750 g	3 min	1-5
		 1000 g	5 min	5
		 720 g		

# Cleaning and Maintenance

**Always unplug the appliance before you clean it.**

**Never immerse the motor unit in water or rinse it under the tap.**

- 1 Clean the beaters and the kneading hooks in warm water with some washing-up liquid or in the dishwasher.
- 2 Clean the motor unit with a moist cloth.

# Úvod

Gratuluje k nákupu a vítáme vás mezi uživateli výrobků společnosti Philips!  
 Chcete-li plně využívat výhod, které nabízí podpora společnosti Philips, zaregistrujte svůj výrobek na adrese [www.philips.com/welcome](http://www.philips.com/welcome).

## Všeobecný popis

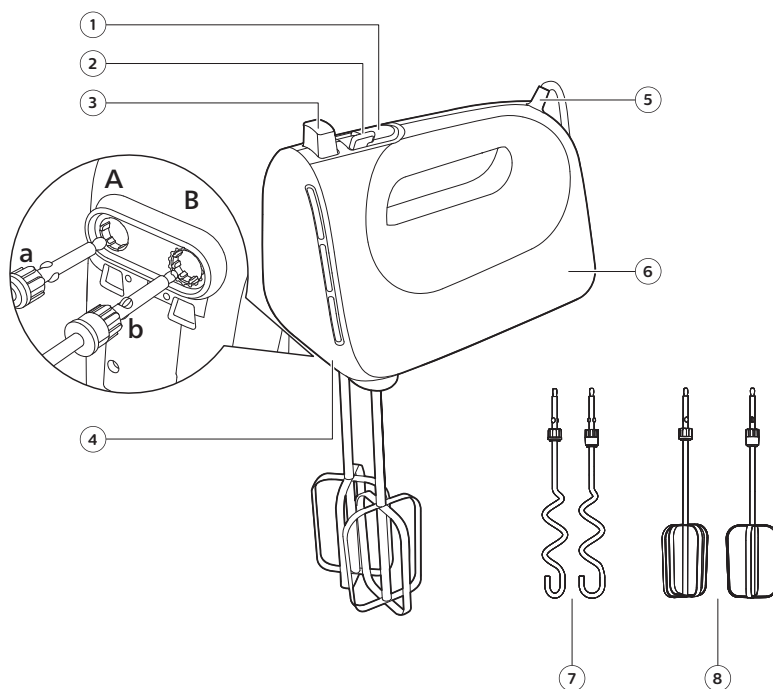

- 1 Tlačítko Turbo  
Stisknutím a podržením dosáhnete maximální rychlosti
- 2 Ovládání rychlosti  
0: Poloha VYPNUTO  
1-5: nastavení rychlosti
- 3 Uvolňovací tlačítko  
Stisknutím tlačítka uvolníte šlehací metly nebo hnětací háky.
- 4 Otvor pro šlehací metly a hnětací háky
- 5 Napájecí kabel
- 6 Hlavní jednotka
- 7 Dva hnětací háky
- 8 Dva šlehací háky

## Před prvním použitím

Před prvním použitím umyjte přístroj a příslušenství teplou mýdlovou vodou. Poté vše důkladně opláchněte a před sestavením zcela usušte. Neumisťujte ho do blízkosti zdrojů tepla, vody nebo hořlavých materiálů.

## Použití přístroje

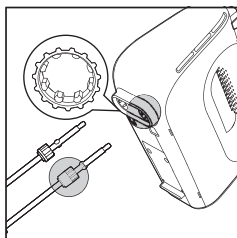

- 1 Metly nebo hnětací háky vložte do hlavní jednotky.

**Hnětací hák nebo metlu s plastovou objímkou vkládejte do většího otvoru.**

- 2 Zasuňte zástrčku do síťové zásuvky.
- 3 Vložte potraviny do mísy.

**Doporučená množství a dobu zpracování naleznete v části Množství surovin a doba zpracování.**

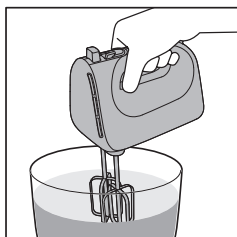

- 4 Metly nebo hnětací háky vložte do nádoby se surovinami.

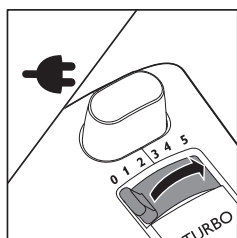

- 5 Přístroj zapnete nastavením ovladače rychlosti na požadovanou rychlost.

**Abyste zabránili stříkání, začněte mixovat při nízké rychlosti. Teprve pak můžete přejít na vyšší rychlost.**

Stisknutím tlačítka turbo urychlíte mixování nebo zvýšíte rychlost zpracování náročnějších surovin, například hnětení kynutého těsta.

Pokud chcete mixování na chvíli zastavit, nastavte ovladač rychlosti do polohy 0, čímž mixér vypnete.

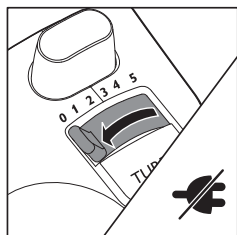



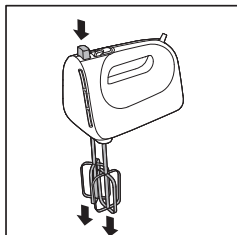







- 6 Po dokončení mixování nastavte ovladač rychlosti do polohy 0 a přístroj odpojte od napájení.

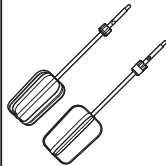

7 Metly nebo hnětačí háky sejmete stisknutím uvolňovacího tlačítka.

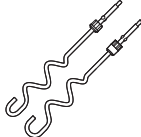
## Množství surovin a doba zpracování

**Nikdy nepřekračujte uvedené maximální množství a dobu zpracování potravin.**





		 Kg (MAX)		
		500 ml	6 min	5
		☺ x8	2 min	5
		750 g	3 min	1-5
		 1000 g	5 min	5
		720 g		

# Čištění a údržba

**Před čištěním přístroj vždy odpojte ze sítě.**

**Motorovou jednotku nesmíte nikdy ponořit do vody ani mýt pod tekoucí vodou.**

- 1 Metly nebo hnětací háky myjte v teplé vodě s prostředkem na umývání nádobí nebo v myčce nádobí.
- 2 Motorovou jednotku čistěte pouze navlhčeným hadříkem.

			
	✗	✗	✓
	✓	✓	✓

# Indledning

Tillykke med dit køb, og velkommen til Philips!

Hvis du vil have fuldt udbytte af den support, som Philips tilbyder, kan du registrere dit produkt på [www.philips.com/welcome](http://www.philips.com/welcome).

## Generel beskrivelse

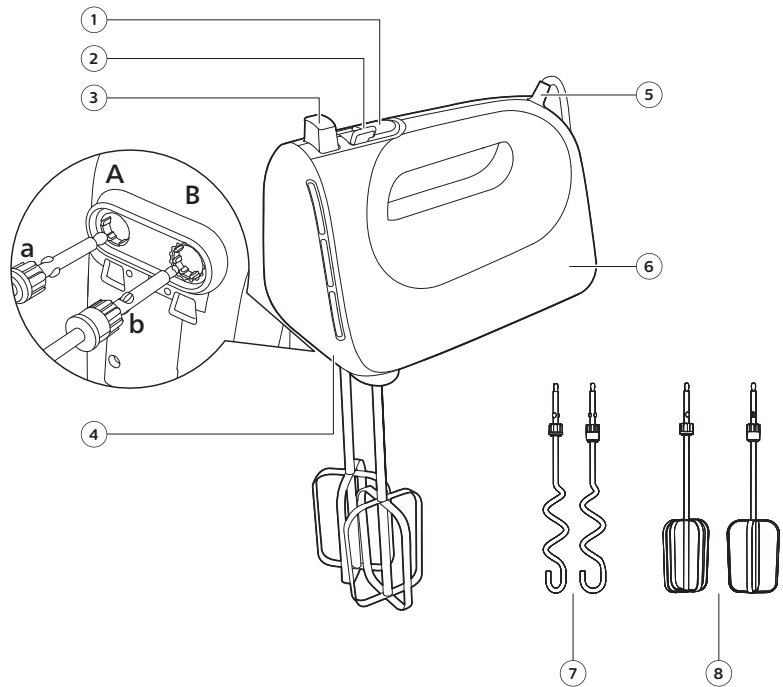

- 1 Turboknap  
Tryk og hold nede for at nå den maksimale hastighed
- 2 Hastighedskontrol  
0: OFF-position  
1-5: hastighedsindstilling
- 3 Udløserknap  
Tryk for at frigøre piskerisene eller dejkrogene
- 4 Hul til piskerisene og dejkrogene
- 5 Netledning
- 6 Hovedenhed
- 7 To dejkroge
- 8 To piskeris

## Før apparatet tages i brug

Vask apparatet og tilbehøret med varmt sæbevand, inden det tages i brug første gang. Skyl delene grundigt, og tør dem helt, inden de samles.

Undgå at placere den i nærheden af varmekilder, vand eller brændbare materialer.

## Sådan bruges apparatet

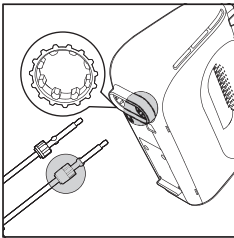

- 1 Indsæt piskeris eller dejkroge i hovedenheden.

**Indsæt piskeriset eller dejkroge med plasticappen i den største af åbningerne.**

- 2 Sæt stikket i stikkontakten.  
3 Kom ingredienserne i en skål.

**Se de anbefalede mængder og tilberedningstider i afsnittet "Mængder og tilberedningstider ved tilberedning".**

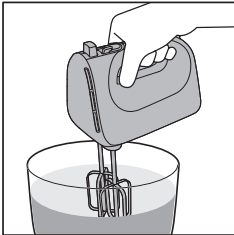

- 4 Sænk piskeris eller dejkroge ned i ingredienserne.

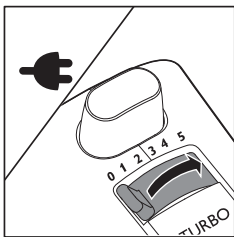

- 5 Sæt hastighedsknappen på den ønskede hastighed for at tænde for apparatet.

**Begynd med lav hastighed for at undgå stænk og sprøjt. Skift gradvist til højere hastighed.**

Tryk på turboknappen for at piske hurtigere eller øge hastigheden ved tunge processer, f.eks. æltning af gærdej.

Hvis du vil afbryde midlertidigt, skal du sætte hastighedskontrollen på "0" for at slukke apparatet.

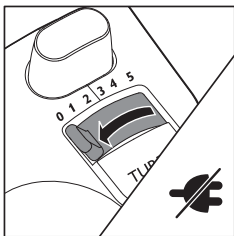

- 6 Efter brug skal du sætte hastighedskontrollen på 0 og tage stikket ud af stikkontakten.



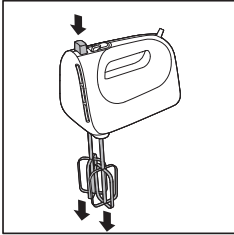









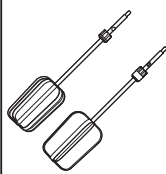

7 Piskeris og dejkroge frigøres ved at trykke på udløserknappen.

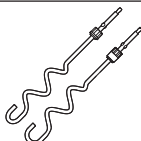
## Mængder og tilberedningstider ved tilberedning

Overskrid ikke de angivne maksimale mængder og tilberedningstider.





		 Kg (MAX)		
		500 ml	6 min	5
		8 x	2 min	5
		750 g	3 min	1-5
		 1000 g	5 min	5
		 720 g		

# Rengøring og vedligeholdelse

**Tag altid stikket ud af stikkontakten, inden apparatet rengøres.**

**Motorenheden må aldrig komme i vand eller skylles under vandhanen.**

- 1 Vask piskeris og dejkroge i varmt vand tilsat lidt opvaskemiddel eller i opvaskemaskinen.
- 2 Motorenheden kan rengøres med en fugtig klud.

			
	✗	✗	✓
	✓	✓	✓

# Einführung

Herzlichen Glückwunsch zu Ihrem Kauf und willkommen bei Philips!  
Um das Kundendienstangebot von Philips vollständig nutzen zu können, registrieren Sie Ihr Produkt unter [www.philips.com/welcome](http://www.philips.com/welcome).

## Allgemeine Beschreibung

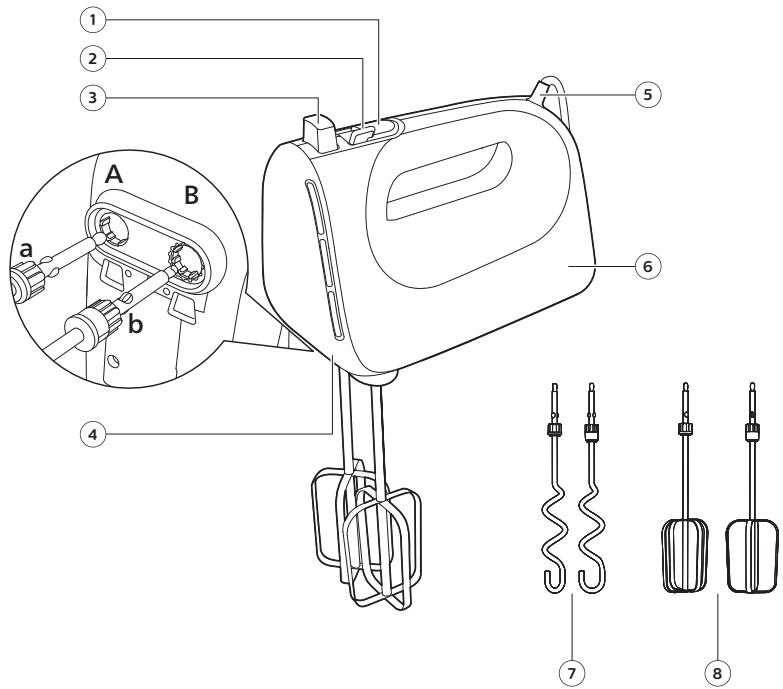

- 1 Turbotaste  
Gedrückt halten für maximale Geschwindigkeit
- 2 Geschwindigkeitskontrolle  
0: Position OFF  
1-5: Geschwindigkeitseinstellung
- 3 Auswurfaste  
Drücken, um die Quirle oder Knethaken zu entfernen
- 4 Öffnung für Quirle und Knethaken
- 5 Netzkabel
- 6 Hauptgerät
- 7 Zwei Knethaken
- 8 Zwei Quirle

## Vor dem ersten Gebrauch

Reinigen Sie das Gerät und die Zubehörteile vor dem ersten Gebrauch mit warmem Seifenwasser. Spülen Sie das Gerät und die Zubehörteile gründlich ab, und trocknen Sie sie vor dem Zusammensetzen vollständig ab.

Stellen Sie das Gerät nicht in der Nähe von Wärmequellen, Wasser oder entflammaren Materialien auf.

## Das Gerät benutzen

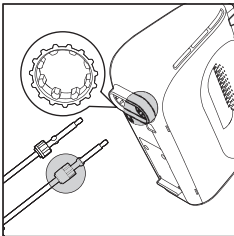

- 1 Stecken Sie die Quirle oder Knethaken in das Hauptgerät.

**Stecken Sie den Quirl oder Knethaken mit dem Plastikstück in die große Öffnung.**

- 2 Stecken Sie den Stecker in die Steckdose.
- 3 Die Zutaten in eine Schüssel geben.

**Sehen Sie sich die empfohlenen Mengen und Verarbeitungszeiten im Abschnitt "Empfohlenen Mengen und Verarbeitungszeiten" an.**

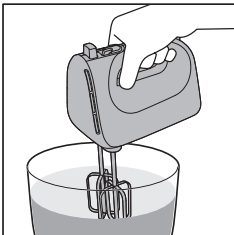

- 4 Führen Sie die Quirle oder den Pürierstab in die Zutaten.

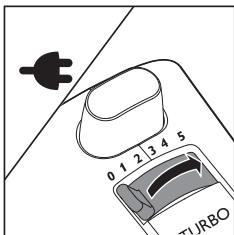

- 5 Stellen Sie den Geschwindigkeitsregler auf die gewünschte Geschwindigkeitseinstellung, um das Gerät einzuschalten.

**Beginnen Sie zum Vermeiden von Spritzern mit einer niedrigen Geschwindigkeit. Wechseln Sie später zu einer höheren Geschwindigkeit.**

Sie können auf die Turbotaste drücken, um Zutaten schneller zu vermengen oder die Geschwindigkeiten während anspruchsvollerer Aufgaben wie dem Verkneten von Hefeteig erhöhen.

Wenn Sie für eine Weile pausieren möchten, dann stellen Sie den Geschwindigkeitsregler einfach auf "0", um das Gerät auszuschalten.

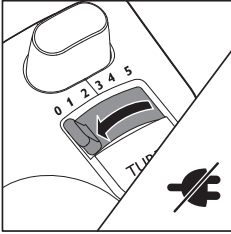



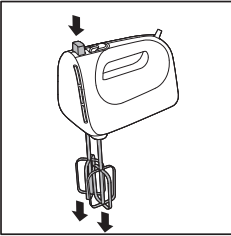







6 Wenn Sie mit dem Mixen fertig sind, dann stellen Sie den Geschwindigkeitsregler einfach auf "0", um das Gerät auszuschalten.

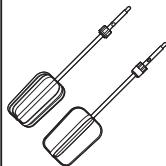

7 Drücken Sie auf die Auswurfaste, um die Quirle und Knethaken auszuwerfen.

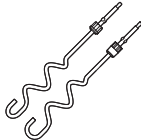
## Verarbeitungsmengen und -zeiten

Überschreiten Sie nicht die angegebenen Höchstmengen und Verarbeitungszeiten.





		 (MAX)		
		500 ml	6 min	5
		☉ x8	2 min	5
		750 g	3 min	1-5
			5 min	5
				

## Reinigung und Wartung

Ziehen Sie vor dem Reinigen des Geräts stets den Netzstecker aus der Steckdose.

Tauchen Sie die Motoreinheit niemals in Wasser. Spülen Sie sie auch nicht unter fließendem Wasser ab.

- 1 Reinigen Sie die Quirle und Knethaken in warmem Spülwasser oder im Geschirrspüler.
- 2 Reinigen Sie die Motoreinheit mit einem feuchten Tuch.

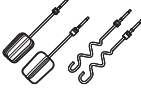
			
	✗	✗	✓
	✓	✓	✓

## Tutvustus

Õnnitleme ostu puhul ja tervitame Philipsi poolt!

Philipsi pakutava tootetoe eeliste täielikuks kasutamiseks registreerige oma toode veebilehel [www.philips.com/welcome](http://www.philips.com/welcome).

## Üldine kirjeldus

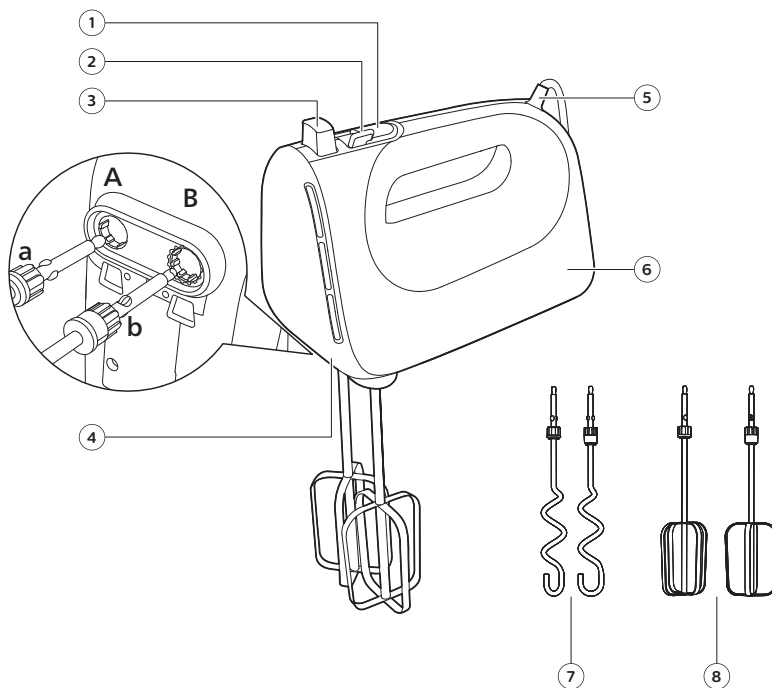

- 1 Turbo-nupp  
Vajutage ja hoidke all, et saavutada maksimaalne kiirus.
- 2 Kiiruse regulaator  
0: asend „OFF”  
1–5: kiiruseadistus
- 3 Vabastusnupp  
Vajutage visplite või tainasegamiskonksude vabastamiseks.
- 4 Avaus visplite ja tainasegamiskonksude jaoks
- 5 Toitekaabel
- 6 Põhiseade
- 7 Kaks tainakonksu
- 8 Kaks visplit

## Enne esimest kasutamist

Enne esmast kasutamist peske seade ja tarvikud sooja seebiveega. Loputage hoolikalt ja kuivatage enne kokkupanekut täielikult.

Ärge asetage seda soojusallikate, vee või tuleohtlike materjalide lähedusse.

## Seadme kasutamine

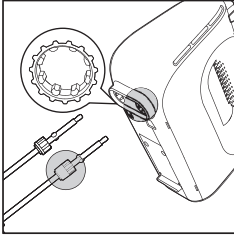

- 1 Sisestage visplid või tainakonksud põhiseadmesse.

**Kinnitage visplid või tainakonksud plastmassist kraega suurematesse avadesse.**

- 2 Sisestage pistik pistikupessa.  
3 Mõõtkoostisained kaussi.

**Soovitavaid koguseid ja töötlemisaegu vaadake jaotisest „Töötlemiskogused ja -ajad“.**

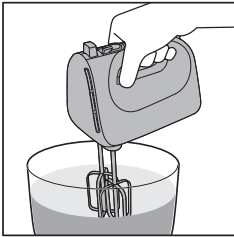

- 4 Suruge visplid või tainakonksud vastu nõu põhja.

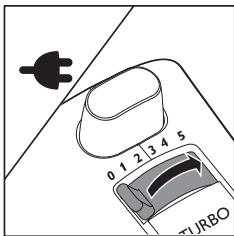

- 5 Seadme sisselülitamiseks seadistage kiirusenupp soovitud kiirusele.

**Alustage segamist madalal kiirusel, et vältida pritsimist. Lülituge hiljem suuremale kiirusele.**

Vajutage turbolülitit, et segamine toimuks kiiremini või raskete ülesannete, nagu näiteks tainasõtkumise ajal suurendataks kiirust.

Kui soovite segamise mõneks ajaks peatada, lülitage seade välja, seades kiiruse regulaatori asendisse „0“.

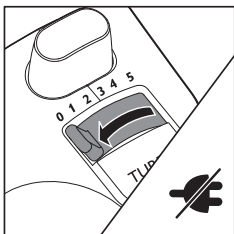

- 6 Kui olete segamise lõpetanud, seadke kiiruse regulaator asendisse „0“ ja võtke pistik seinakontaktist välja.



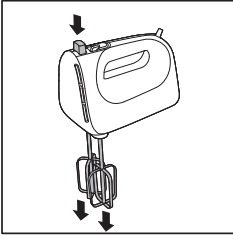







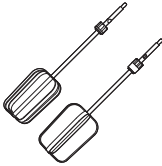

7 Visplite või tainakonsude vabastamiseks vajutage vabastusnuppu.

## Töötlemiskogused ja -aeg

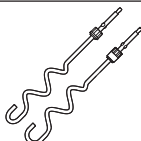
Ärge ületage viidatud maksimaalset kogust ega töötlemise kestust.





		 Kg (MAX)		
		500 ml	6 min	5
		8 x	2 min	5
		750 g	3 min	1-5
		1000 g	5 min	5
		720 g		

# Puhastamine ja hooldus

**Tõmmake seadme pistik alati enne puhastamist seinakontaktist välja.**

**Ärge kastke kunagi mootorit vette ega peske voolava vee all.**

- 1 Peske vispleid ja tainakonkse sooja veega, millesse on lisatud vedelat pesemisvahendit või nõudepesumasinas.
- 2 Puhastage mootorit niiske lapiga.

			
	✗	✗	✓
	✓	✓	✓

# Introducción

Le damos la enhorabuena por su adquisición y la bienvenida a Philips.

Para poder beneficiarse por completo de la asistencia que ofrece Philips, registre el producto en [www.Philips.com/welcome](http://www.Philips.com/welcome).

# Descripción general

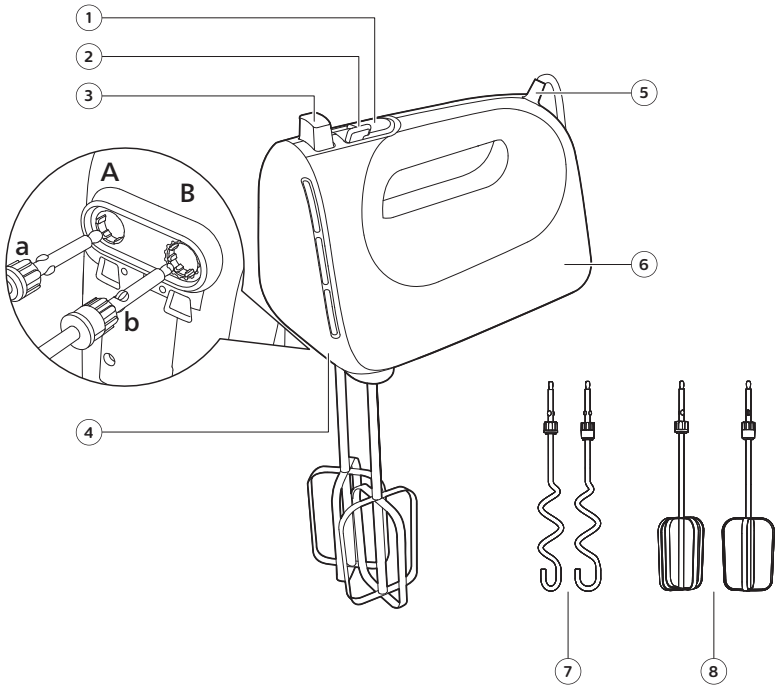

- 1 Botón turbo  
Manténgalo pulsado para alcanzar la velocidad máxima
- 2 Control de velocidad  
0: posición de apagado  
1-5: posiciones de velocidad
- 3 Botón de expulsión  
Púlselo para quitar las varillas para batir y los ganchos para amasar
- 4 Orificio para las varillas para batir y los ganchos para amasar
- 5 Cable de alimentación
- 6 Unidad principal
- 7 Dos ganchos para amasar
- 8 Dos varillas batidoras

## Antes de utilizarlo por primera vez

Antes del primer uso, lave el aparato y los accesorios con agua jabonosa tibia. Enjuáguelos bien y séquelos completamente antes de ensamblarlos. Evite colocarla cerca de fuentes de calor, agua o materiales inflamables.

## Uso del aparato

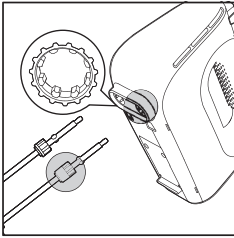

- 1 Inserte las varillas batidoras o los ganchos amasadores en la unidad principal.

**Inserte la varilla batidora o el gancho amasador con la arandela de plástico en la abertura más grande.**

- 2 Enchufe el aparato a la toma de corriente.
- 3 Ponga los ingredientes en el recipiente.

**Consulte las cantidades y los tiempos de procesamiento recomendados en el apartado "Cantidades y tiempos de procesamiento".**

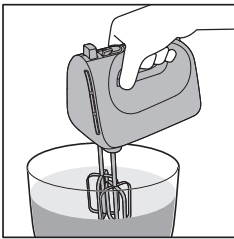

- 4 Introduzca las varillas batidoras o los ganchos para amasar en los ingredientes.

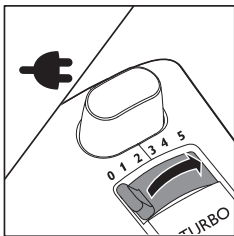

- 5 Coloque el control de velocidad en la posición deseada para encender el aparato.

**Empiece a mezclar a baja velocidad para evitar salpicaduras. Vaya aumentando la velocidad progresivamente.**

Puede pulsar el botón Turbo para mezclar más rápidamente o para aumentar la velocidad durante determinadas tareas exigentes, como amasar masa de levadura.

Si desea dejar de mezclar durante un tiempo, ajuste el control de velocidad a la posición "0" para apagar el aparato.

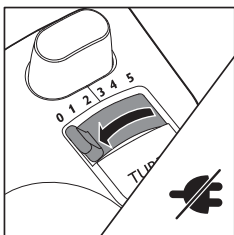



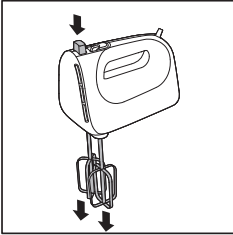





- 6 Cuando haya terminado, coloque el control de velocidad en la posición "0" y desenchufe el aparato.

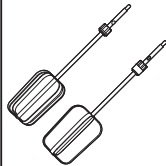

7 Para liberar las varillas batidoras o los ganchos amasadores, presione el botón de expulsión.

## Cantidades y tiempos de procesamiento

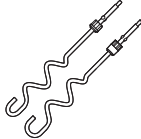
No supere los valores máximos de cantidades y tiempos de procesamiento indicados.

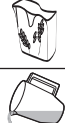



		 Kg (MAX)		
		500 ml	6 min	5
		 x8	2 min	5
		750 g	3 min	1-5
		1000 g	5 min	5
		720 g		

# Limpeza y mantenimiento

**Desenchufe siempre el aparato antes de limpiarlo.**

**No sumerja nunca la unidad motora en agua ni la enjuague bajo el grifo.**

- 1 Lave las varillas batidoras y los ganchos amasadores con agua tibia y un poco de detergente líquido, o en el lavavajillas.
- 2 Limpie la unidad motora con un paño húmedo.

			
	✗	✗	✓
	✓	✓	✓

# Introduction

Félicitations pour votre achat et bienvenue chez Philips !

Pour profiter pleinement de l'assistance offerte par Philips, enregistrez votre appareil à l'adresse suivante : [www.philips.com/welcome](http://www.philips.com/welcome).

## Description générale

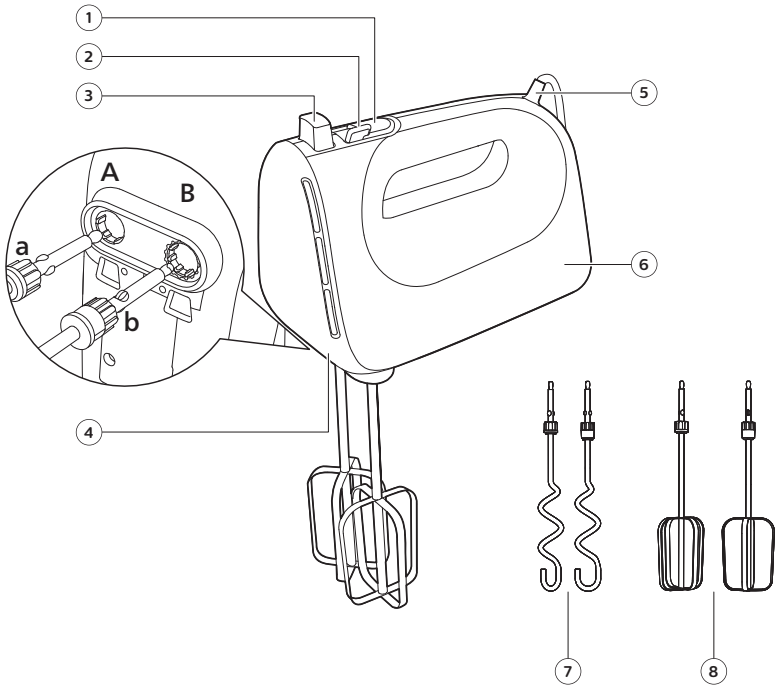

- 1 Bouton Turbo  
Maintenez ce bouton enfoncé pour atteindre la vitesse maximale
- 2 Contrôle de la vitesse  
0 : Position ARRÊT  
1-5 : réglage de la vitesse
- 3 Bouton d'éjection  
Appuyez sur ce bouton pour libérer les fouets ou les crochets de pétrissage
- 4 Trou pour les fouets et les crochets de pétrissage
- 5 Cordon d'alimentation
- 6 Unité principale
- 7 Deux crochets de pétrissage
- 8 Deux fouets

## Avant la première utilisation

Avant la première utilisation, lavez l'appareil et ses accessoires à l'eau chaude savonneuse. Rincez-les soigneusement et séchez-les complètement avant de les assembler.

Évitez de le placer près de sources de chaleur, d'eau ou de matériaux inflammables.

## Utilisation de l'appareil

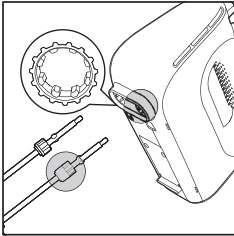

- 1 Insérez les fouets ou les crochets de pétrissage dans l'unité principale.

**Introduisez le fouet ou le crochet de pétrissage équipé du collier en plastique dans la plus grande ouverture.**

- 2 Branchez le cordon d'alimentation sur la prise secteur.
- 3 Placez les ingrédients dans un saladier.

**Reportez-vous aux quantités et temps de préparation recommandés dans la section « Quantités et temps de préparation ».**

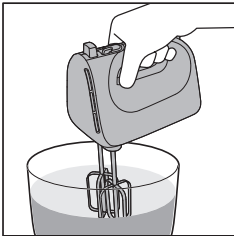

- 4 Placez les fouets ou les crochets à pétrir dans les ingrédients.

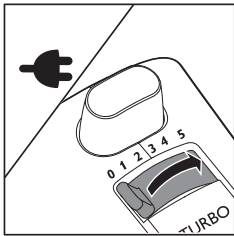

- 5 Réglez le variateur de vitesse sur la vitesse souhaitée avant d'allumer l'appareil.

**Commencez à vitesse réduite pour éviter les éclaboussures. Augmentez la vitesse ultérieurement.**

Vous pouvez appuyer sur le bouton Turbo pour mélanger plus rapidement ou pour augmenter la vitesse pendant les opérations plus difficiles, par exemple pour pétrir de la pâte à pain.

Si vous souhaitez interrompre l'opération, réglez le variateur de vitesse sur 0 pour éteindre l'appareil.

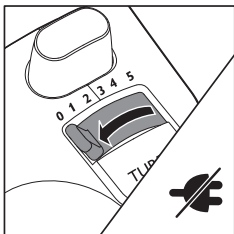

- 6 Lorsque vous avez fini, réglez le variateur de vitesse sur 0 et débranchez l'appareil.



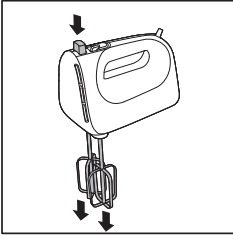









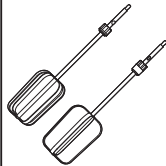

7 Pour libérer les fouets ou les crochets de pétrissage, appuyez sur le bouton d'éjection.

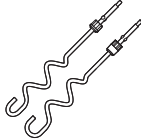
## Quantités à préparer et temps de préparation

Ne dépassez pas les quantités et les temps de fonctionnement maximaux indiqués.





		 Kg (MAX)		
		500 ml	6 min	5
		 x8	2 min	5
		750 g	3 min	1-5
		 1000 g	5 min	5
		720 g		

# Nettoyage et entretien

**Débranchez toujours l'appareil avant de le nettoyer.**

**Ne plongez jamais le bloc moteur dans l'eau et ne le rincez pas sous le robinet.**

- 1 Nettoyez les fouets et les crochets à l'eau chaude additionnée d'un peu de liquide vaisselle ou au lave-vaisselle.
- 2 Nettoyez le bloc moteur à l'aide d'un chiffon humide.

			
	✗	✗	✓
	✓	✓	✓

## Uvod

Čestitamo Vam na kupnji i dobro došli u Philips!

Kako biste potpuno iskoristili podršku koju nudi Philips, registrirajte svoj proizvod na [www.philips.com/welcome](http://www.philips.com/welcome).

## Opći opis

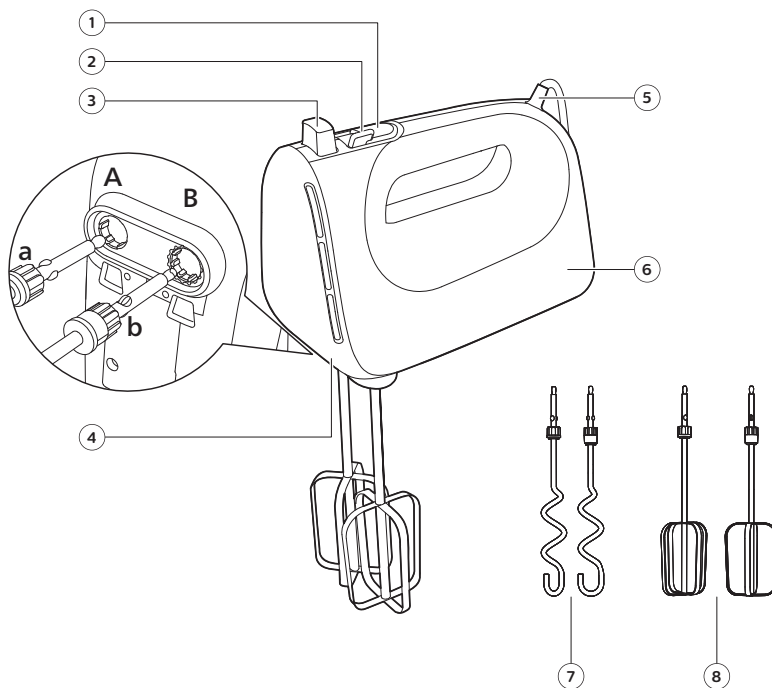

- 1 Gumb Turbo  
Pritisnite i zadržite za dosezanje maksimalne brzine
- 2 Kontrola brzine  
0: položaj OFF (isključeno)  
1 – 5: postavka brzine
- 3 Gumb za izbacivanje  
Pritisnite kako biste oslobodili nastavke za miješanje ili kuke za tijesto
- 4 Otvor za nastavke za miješanje i kuke za tijesto
- 5 Kabel za napajanje
- 6 Glavna jedinica
- 7 Dvije kuke za tijesto
- 8 Dva nastavka za miješanje

## Prije prve uporabe

Prije prve uporabe operite aparat i dodatke toplom vodom sa sapunicom. Dobro ih isperite i u potpunosti osušite prije sastavljanja.

Nemojte ga postavljati u blizini izvora topline, vode ili zapaljivih materijala.

## Uporaba aparata

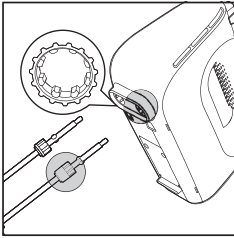

- 1 Umetnite nastavke za miješanje ili kuke za tijesto u glavnu jedinicu.

**Nastavak za miješanje ili kuke za tijesto koja ima plastični prsten umetnite u veći otvor.**

- 2 Ukopčajte utikač u zidnu utičnicu.
- 3 Stavite sastojke u zdjelu.

**Preporučene količine i vrijeme obrade potražite u odjeljku „Količine i vrijeme obrade“.**

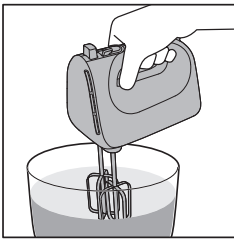

- 4 Spustite nastavke za miješanje ili kuke za tijesto u sastojke.

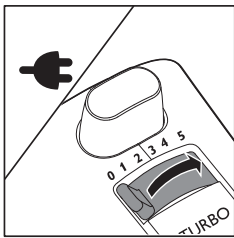

- 5 Kako biste uključili aparat, regulator brzine postavite na željenu postavku brzine.

**Započnite miješanje na nižoj brzini kako biste izbjegli prskanje. Poslije prijedite na veću brzinu.**

Možete pritisnuti gumb turbo za brže miješanje ili povećanje brzine tijekom miješanja gušćih sastojaka, npr. kada se mijesi tijesto.

Ako želite privremeno zaustaviti miješanje, kontrolu brzine postavite na „0“ kako biste isključili aparat.

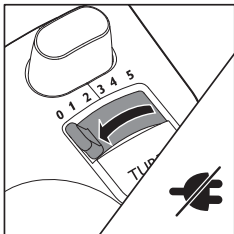



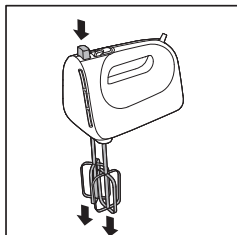







- 6 Kada završite miješanje, kontrolu brzine postavite na „0“ i iskopčajte aparat.

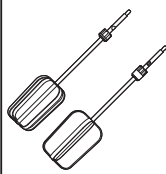

- 7 Kako biste otpustili nastavke za miješanje ili kuke za tijesto, pritisnite gumb za izbacivanje.

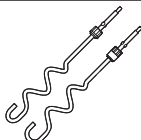
## Količine za obradu i vrijeme obrade

**Nemojte premašiti naznačene maksimalne količine i vrijeme obrade.**





		 Kg (MAX)		
		500 ml	6 min	5
		8 x	2 min	5
		750 g	3 min	1-5
		 1000 g	5 min	5
		 720 g		

# Čišćenje i održavanje

**Prije čišćenja aparata kabel za napajanje obavezno iskopčajte iz utičnice.**

**Jedinicu motora nikada nemojte uranjati u vodu niti je ispirati pod mlazom vode.**

- 1 Nastavke za miješanje i kuke za tijesto perite u toploj vodi s malo deterdženta ili u perilici posuda.
- 2 Jedinicu motora čistite vlažnom krpom.

			
	✗	✗	✓
	✓	✓	✓

# Introduzione

Congratulazioni per l'acquisto e benvenuti in Philips.  
Per trarre il massimo vantaggio dall'assistenza fornita da Philips, registrare il proprio prodotto sul sito [www.philips.com/welcome](http://www.philips.com/welcome).

# Descrizione generale

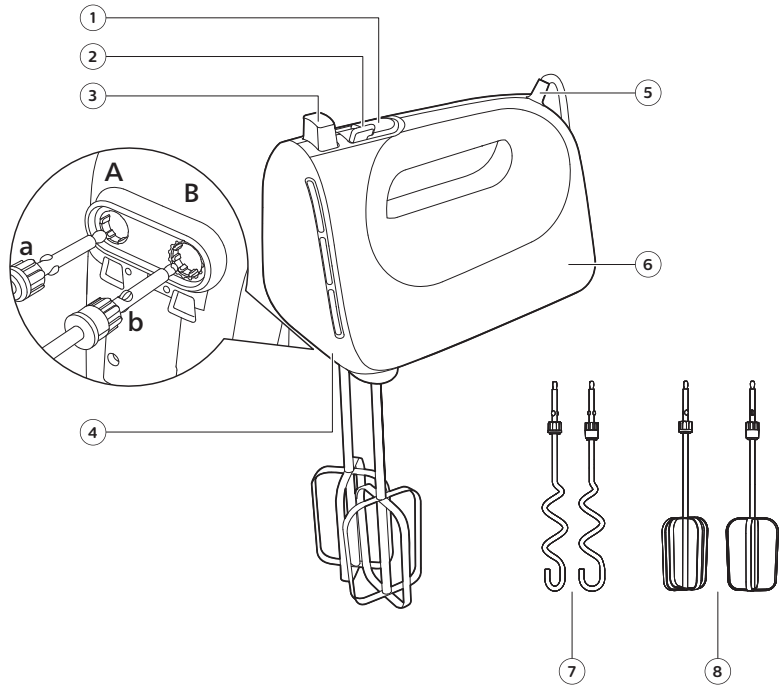

- 1 Pulsante Turbo  
Tenere premuto per raggiungere la velocità massima
- 2 Selettore della velocità  
0: posizione OFF  
1-5: impostazioni di velocità
- 3 Pulsante di espulsione  
Premere per sganciare le fruste o i ganci per impastare
- 4 Foro per fruste e ganci per impastare
- 5 Cavo di alimentazione
- 6 Unità principale
- 7 Due ganci per impastare
- 8 Due fruste

# Prima di utilizzare l'apparecchio per la prima volta

Prima del primo utilizzo, lavare l'apparecchio e gli accessori con acqua calda e sapone. Sciacquarli accuratamente e asciugarli completamente prima di assemblarli.

Non posizionarlo vicino a fonti di calore, acqua o materiali infiammabili.

## Utilizzo dell'apparecchio

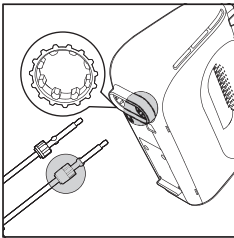

- 1 Inserire le fruste o i ganci per impastare nell'unità principale.

**Inserire la frusta o il gancio per impastare con l'anello in plastica nell'apertura più grande.**

- 2 Inserire la spina nella presa di corrente a muro.
- 3 Mettere gli ingredienti nel recipiente.

**Consultare le quantità consigliate e i tempi di lavorazione nella sezione "Dosi e tempi di lavorazione".**

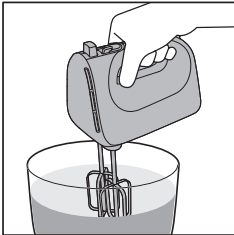

- 4 Immergere le fruste o i ganci per impastare negli ingredienti.

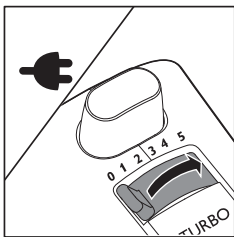

- 5 Impostare il selettore della velocità sul valore desiderato per accendere l'apparecchio.

**Iniziare a miscelare a bassa velocità per evitare schizzi. Passare successivamente a una velocità più alta.**

È possibile premere il pulsante Turbo per miscelare più rapidamente o aumentare la velocità durante le preparazioni più complesse, ad esempio per impasti vari.

Se si desidera interrompere momentaneamente la miscelazione, impostare il selettore della velocità "0" per spegnere l'apparecchio.

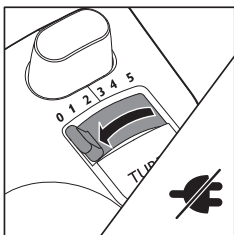

- 6 Al termine della miscelazione, impostate il selettore della velocità su "0" e scollegare l'apparecchio.



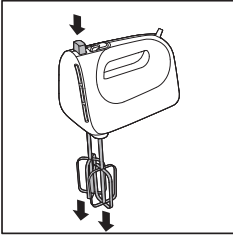









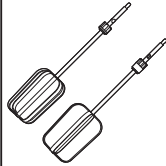

7 Per sganciare le fruste o i ganci per impastare, premere il pulsante di espulsione.

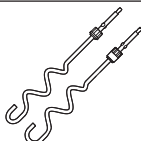
## Dosi e tempi di lavorazione

**Non superare le quantità massime e i tempi di preparazione indicati.**





		 Kg (MAX)		
		500 ml	6 min	5
		8 x 	2 min	5
		750 g	3 min	1-5
		 1000 g	5 min	5
		 720 g		

## Pulizia e manutenzione

**Prima di pulire l'apparecchio, rimuovere sempre la spina dalla presa di corrente.**

**Non immergere il gruppo motore in acqua e non sciacquarlo mai sotto l'acqua corrente.**

- 1 Lavare le fruste e i ganci per impastare in acqua calda con un po' di detersivo liquido oppure direttamente in lavastoviglie.
- 2 Pulire il gruppo motore con un panno umido.

			
	✗	✗	✓
	✓	✓	✓

# Ievads

Apsveicam ar pirkumu un laipni lūdzam Philips!

Lai pīlnībā gūtu labumu no Philips piedāvātā atbalsta, reģistrējiet savu izstrādājumu [www.philips.com/welcome](http://www.philips.com/welcome).

## Vispārīgs apraksts

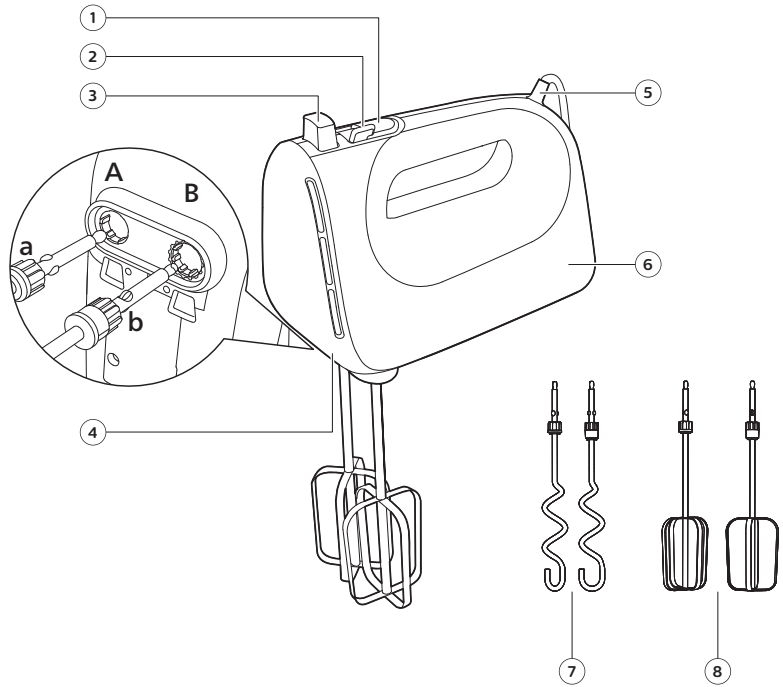

- 1 Turbo poga  
Nospiediet un turiet, lai sasniegtu maksimālo ātrumu
- 2 Ātruma kontrole  
0: ierīce izslēgta  
1–5: ātruma iestatījumi
- 3 Izstumšanas poga  
Nospiediet, lai izņemtu putotājus vai mīklas āķus
- 4 Putotāju un mīklas āķu atvere
- 5 Strāvas padeves vads
- 6 Galvenais bloks
- 7 Divi mīklas āķi
- 8 Divi putotāji

## Pirms pirmās lietošanas reizes

Pirms pirmās lietošanas reizes nomazgājiet ierīci un piederumus ar siltu ziepju ūdeni. Rūpīgi noskalojiet un pirms samontēšanas ļaujiet pilnībā nožūt. Nenovietojiet siltuma avotu, ūdens vai viegli uzliesmojošu materiālu tuvumā.

## Ierīces lietošana

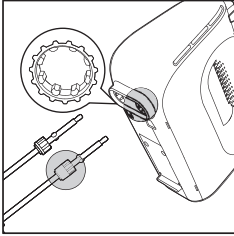

1 Ievietojiet putotājus vai mīcīšanas āķus ierīcē.

**Ievietojiet putotāju vai mīcīšanas āķi ar plastmasas gredzenu ierīces lielākajā atverē.**

2 Iespraudiet kontaktdakšu kontaktligzdā.

3 Ievietojiet traukā produktus.

**Ieteicamos daudzumus un apstrādāšanas ilgumu skatiet sadaļā "Apstrādājamo produktu daudzums un apstrādāšanas ilgums".**

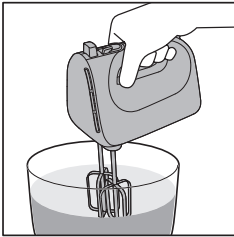

4 Iegremdējiet putotājus vai mīcīšanas āķus produktos.

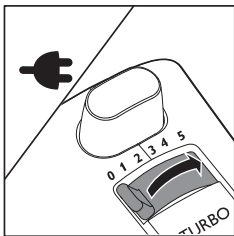

5 Noregulējiet vadības slīdslēdzi vēlamajā ātrumā iestatījumā, lai ieslēgtu ierīci.

**Lai neizšļakstītu produktus, vispirms ieslēdziet mikseri mazā ātrumā. Pēc tam pārslēdziet uz lielāku ātrumu.**

Lai paātrinātu darbību vai palielinātu ātrumu grūti mīcāmu vai kuļamu produktu apstrādes laikā, piemēram, mīcot rauga mīklu, nospiediet turbo pogu.

Ja vēlaties uz brīdi pārtraukt darbību, pārvirziet ierīces ātruma kontroles slēdzi pozīcijā "0", lai izslēgtu ierīci.

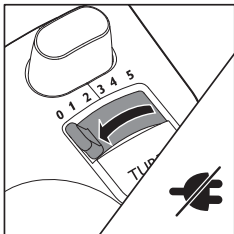



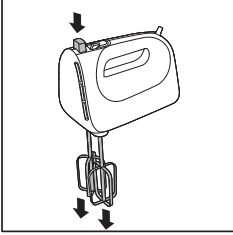







6 Kad kuļšana ir pabeigta, pārvirziet ierīces ātruma kontroles slēdzi pozīcijā "0", un atvienojiet ierīci no elektrotīkla.

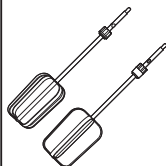

7 Lai atbrīvotu putotājus vai mīcīšanas āķus, nospiediet izstumšanas pogu.

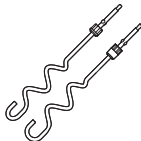
## Apstrādājamo produktu daudzums un apstrādes laiks

Nepārsniedziet norādīto maksimālo produktu daudzumu un apstrādes ilgumu.





		 Kg (MAX)		
		500 ml	6 min	5
		8 x	2 min	5
		750 g	3 min	1-5
		 1000 g	5 min	5
		 720 g		

## Tīrīšana un apkope

**Pirms ierīces tīrīšanas atvienojiet to no elektrotīkla.**

**Miksera motora nodaļījumu aizliegts mērkēt ūdenī un skalot tekošā ūdenī.**

- 1 Nomazgājiet putotājus un mīcīšanas āķus siltā ūdenī, kam pievienots trauku mazgāšanas līdzeklis, vai trauku mazgājamajā mašīnā.
- 2 Tīriet motora bloku ar mitru drānu.

			
	✗	✗	✓
	✓	✓	✓

## Įvadas

Sveikiname įsigijus „Philips“ gaminį ir sveiki atvykę!

Norėdami pasinaudoti „Philips“ siūloma pagalba, užregistruokite savo gaminį adresu [www.philips.com/welcome](http://www.philips.com/welcome).

## Bendrasis aprašymas

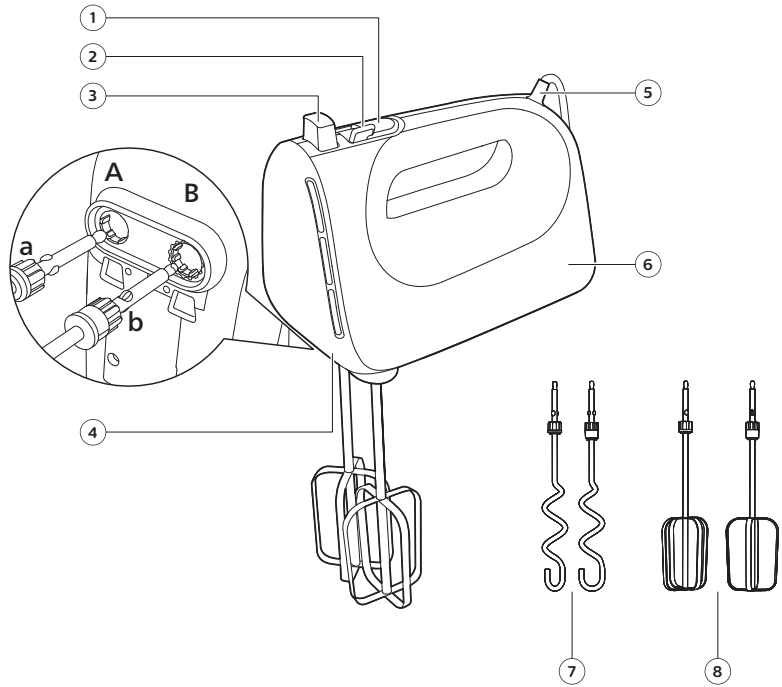

- 1 Turbo mygtukas  
Paspauskite ir laikykite, kad pasiektumėte didžiausią greitį
- 2 Greičio jungiklis  
0 pav.: IŠJUNGIMO padėtis  
1–5 greičio nustatymai
- 3 Išstūmimo mygtukas  
Paspauskite, kad atsilaisvintumėte plaktuvėlius arba tešlos minkytuvėlius
- 4 Anga plaktuvėliams ir tešlos minkytuvėliams
- 5 Maitinimo laidas
- 6 Pagrindinis įrenginys
- 7 Du tešlos minkytuvėliai
- 8 Du plaktuvėliai

## Prieš naudojant pirmą kartą

Prieš pirmą kartą naudodami prietaisą ir priedus nuplaukite šiltu muiluotu vandeniu. Prieš surinkdami kruopščiai praskalaukite ir visiškai išdžiovinkite. Nestatykite šalia šilumos šaltinių, vandens ar degių medžiagų.

## Prietaiso naudojimas

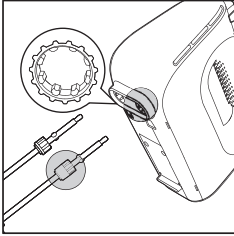

1 Įdėkite plaktuvėlius arba minkytuvėlius į pagrindinį įrenginį.

**Plaktuvėlį arba minkytuvėlį su plastmasiniu žiedeliu įstatykite į didesnę angą.**

2 Įkiškite į maitinimo lizdą kištuką.

3 Sudėkite produktus į dubenį.

**Rekomenduojamus kiekius ir ruošimo trukmę žr. skyriuje „Ruošimo kiekiai ir ruošimo trukmė“.**

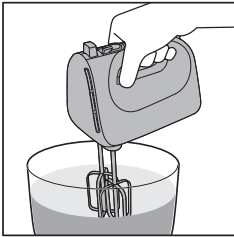

4 Įleiskite plaktuvėlius arba minkytuvėlius į produktus.

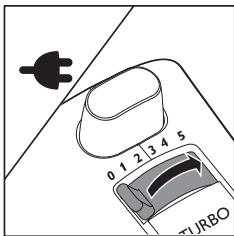

5 Norėdami įjungti prietaisą, nustatykite greičio reguliatorių į norimo greičio padėtį.

**Pradėkite maišyti mažais greičiais, kad neapsitaškytumėte. Vėliau pereikite prie didesnio greičio.**

Norėdami plakti greičiau arba padidinti tirštų produktų, pvz., mielinės tešlos, minkymo greitį, paspauskite turbo mygtuką.

Jei norite trumpam nutraukti maišymą, nustatykite greičio jungiklį į „0“ padėtį, kad išjungtumėte prietaisą.

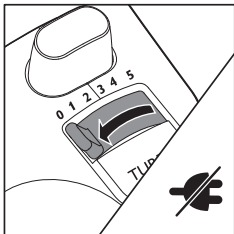

6 Kai pabaigsite plakti, nustatykite greičio reguliatorių į „0“ padėtį ir ištraukite kištuką iš elektros tinklo.



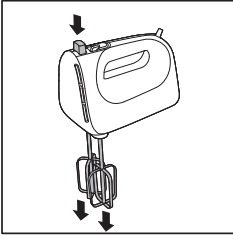









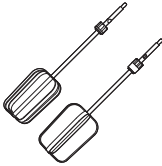

7 Norėdami išimti plaktuvėlius arba tešlos minkytuvėlius, paspauskite išstūmimo mygtuką.

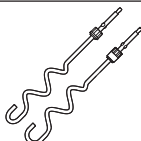
## Apdorojami kiekiai ir apdorojimo trukmė

**Neviršykite didžiausių kiekių ir maisto ruošimo laiko.**





		 Kg (MAX)		
		500 ml	6 min	5
		☉ x8	2 min	5
		750 g	3 min	1-5
		 1000 g	5 min	5
		720 g		

## Valymas ir priežiūra

**Prieš pradėdami valyti prietaisą, visada jį išjunkite iš elektros tinklo.**

**Variklio niekada nemerkite į vandenį ir neskalaukite jo po tekančiu vandeniu.**

- 1 Plaktuvėlius ir minkytuvėlius plaukite šiltu vandeniu su indų plovikliu arba indaplovėje.
- 2 Prietaisą su varikliu nuvalykite drėgna šluoste.

			
	✗	✗	✓
	✓	✓	✓

## Bevezetés

A Philips köszönti Önt! Gratulálunk a vásárláshoz!

A Philips által biztosított teljes körű támogatáshoz regisztrálja termékét a [www.philips.com/welcome](http://www.philips.com/welcome) oldalon.

## Általános leírás

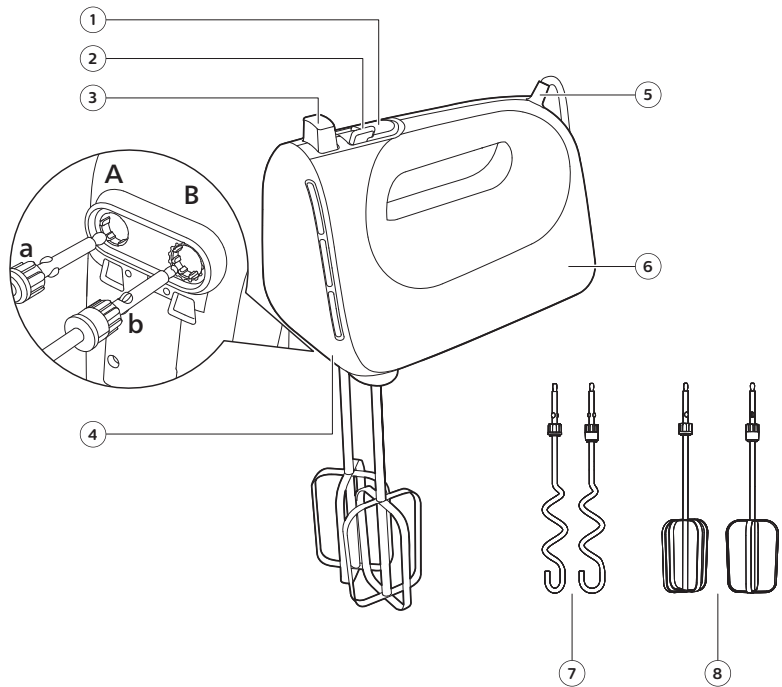

- 1 Turbó gomb  
Nyomja meg és tartsa lenyomva a maximális sebesség eléréséhez
- 2 Sebességszabályozó  
0: OFF (KI) pozíció  
1–5: sebességfokozat
- 3 Kiadó gomb  
A gomb megnyomásával a készülék kiadja a behelyezett habverőket vagy dagasztóhorgokat
- 4 Nyílás a habverők és dagasztóhorgok számára
- 5 Hálózati kábel
- 6 Főegység
- 7 Két dagasztóhorg
- 8 Két habverő

## Teendők az első használat előtt

Az első használat előtt meleg szappanos vízzel mossa el a készüléket és a tartozékokat. Alaposan öblítse le, és összeszerelés előtt teljesen szárítsa meg őket.

Ne helyezze hőforrás, víz vagy gyúlékony anyagok közelébe.

## A készülék használata

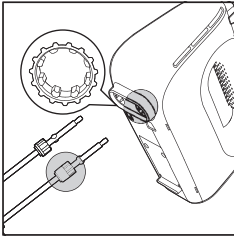

1 Illessze be a habverőket vagy dagasztóhorgokat a főegységbe.

**A műanyag peremmel rendelkező habverőt vagy dagasztóhorgot a nagyobbik nyílásba illessze be.**

2 Csatlakoztassa a hálózati dugót a fali aljzatba.

3 Tegye a hozzávalókat egy tálba.

**Az ajánlott mennyiségeket és feldolgozási időket lásd a „Feldolgozási mennyiségek és feldolgozási idők” című részben.**

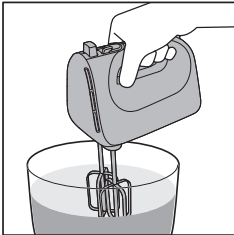

4 Engedje bele a habverőket vagy dagasztóhorgokat a hozzávalókba.

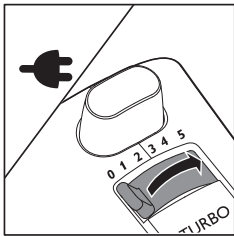

5 A sebességszabályozó kívánt sebességfokozatra állításával kapcsolja be a készüléket.

**A kifröccsenés megakadályozása érdekében alacsony sebességen kezdje a keverést. Később váltson nagyobb sebességre.**

A gyorsabb keveréshez vagy nehezebb feladat esetén – pl. kelt tészta dagasztásakor – a sebesség növeléséhez nyomja meg a turbó gombot.

Ha egy időre abba szeretné hagyni a keverést, a sebességszabályozó „0” helyzetbe állításával kapcsolhatja ki a készüléket.

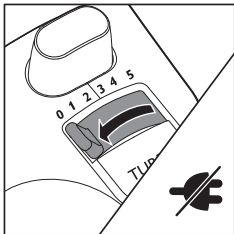



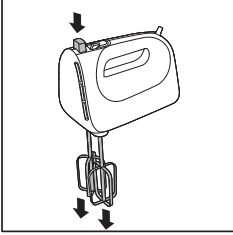







6 Ha befejezte a keverést, állítsa a sebességszabályozót „0” helyzetbe, és húzza ki a készülék hálózati csatlakozódugóját a konnektorból.

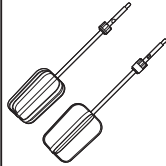

7 A habverők vagy dagasztóhorgok kiengedéséhez nyomja meg a kiadó gombot.

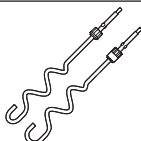
## Feldolgozási mennyiségek és feldolgozási idő

Ne lépje túl az alább jelzett maximális mennyiséget és használati időt.





		 Kg (MAX)		
		500 ml	6 min	5
		8 x	2 min	5
		750 g	3 min	1-5
		 1000 g	5 min	5
		720 g		

# Tisztítás és karbantartás

**Tisztítás előtt mindig húzza ki a készülék hálózati dugóját a fali aljzatból.**

**Ne merítse a motoregységet vízbe, és ne öblítse le csapvíz alatt sem.**

- 1 A habverőket és dagasztóhorgokat mosogatószeres meleg vízben vagy mosogatógépben tisztítsa.
- 2 A motoregységet nedves ruhával tisztítsa.

			
	✗	✗	✓
	✓	✓	✓

# Introductie

Gefeliciteerd met uw aankoop en welkom bij Philips!

Registreer uw product op [www.philips.com/welcome](http://www.philips.com/welcome) om optimaal gebruik te kunnen maken van de door Philips geboden ondersteuning.

## Algemene beschrijving

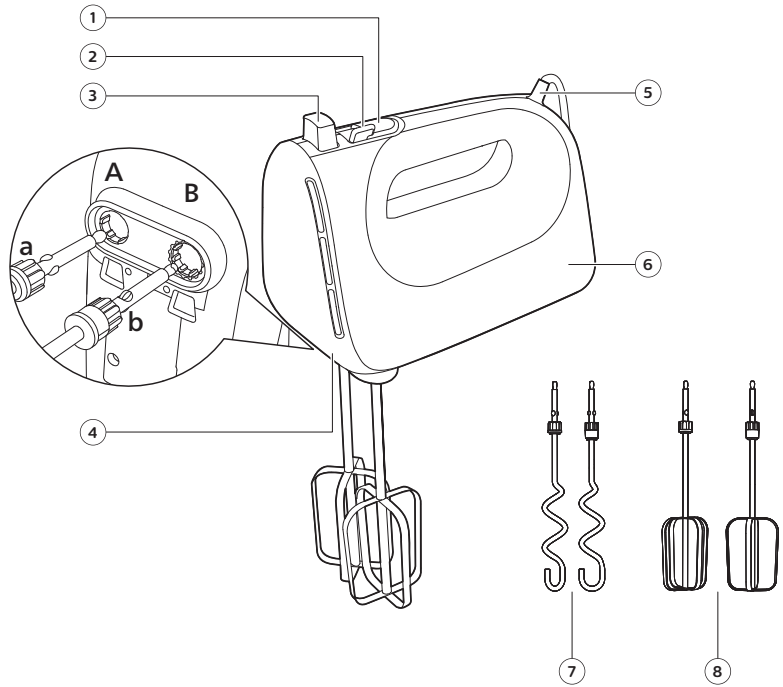

- 1 Turboknop  
Houd deze ingedrukt voor de maximale snelheid
- 2 Snelheidsregeling  
0: UIT-stand  
1-5: snelheidsinstelling
- 3 Uitwerpknop  
Druk hierop om de kloppers of kneedhaken te verwijderen
- 4 Gat voor de kloppers en kneedhaken
- 5 Voedingskabel
- 6 Apparaat
- 7 Twee kneedhaken
- 8 Twee kloppers

## Voor het eerste gebruik

Maak het apparaat en de accessoires voor het eerste gebruik schoon met warm water en afwasmiddel. Spoel en droog ze grondig voordat u alles in elkaar zet.

Plaats hem niet in de buurt van warmtebronnen, water of ontvlambare materialen.

## Het apparaat gebruiken

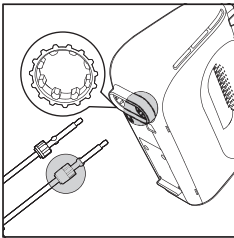

- 1 Plaats de kloppers of kneedhaken in het apparaat.

**Steek de klopper of kneedhaak met de plastic kraag in de grotere opening.**

- 2 Steek de stekker in het stopcontact.

- 3 Plaats de ingrediënten in de kom.

**Raadpleeg voor de aanbevolen hoeveelheden en verwerkingstijden het gedeelte 'Verwerkingshoeveelheden en -tijden'.**

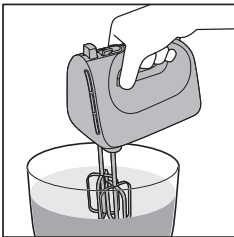

- 4 Laat de kloppers of kneedhaken in de ingrediënten zakken.

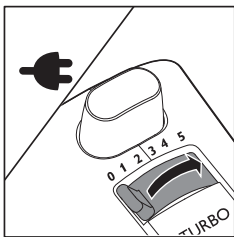

- 5 Stel de snelheid in de op de gewenste instelling en schakel het apparaat in.

**Begin op een lage snelheid met mixen om spatten te voorkomen. Schakel later naar een hogere snelheid.**

U kunt de turboknop indrukken om sneller te mixen of de snelheid te verhogen bij zware taken, bijvoorbeeld het kneden van gistdeeg.

Als u even wilt stoppen met mixen, zet u de snelheidsregeling op '0' om het apparaat uit te schakelen.

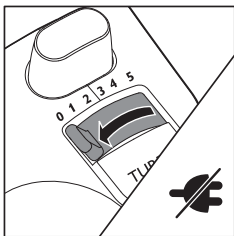

- 6 Wanneer u klaar bent met mixen, zet u de snelheidsregeling op '0' en haalt u de stekker uit het stopcontact.



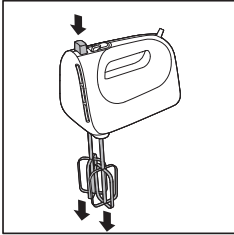









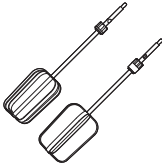

7 Druk op de uitwerpknop om de kloppers of kneedhaken te verwijderen.

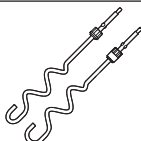
## Verwerkbare hoeveelheden en verwerkingstijd

**Overschrijd de hoeveelheden en bereidingstijden die zijn aangegeven niet.**





		 Kg (MAX)		
		500 ml	6 min	5
		8 x 	2 min	5
		750 g	3 min	1-5
		 1000 g	5 min	5
		 720 g		

# Reiniging en onderhoud

**Haal altijd de stekker uit het stopcontact voordat u het apparaat schoonmaakt.**

**Dompel de motorunit niet in water en spoel deze ook niet af.**

- 1 Maak de kloppers en de kneedhaken schoon in warm water met een beetje afwasmiddel of in de vaatwasmachine.
- 2 Maak de motorunit schoon met een vochtige doek.

			
	✗	✗	✓
	✓	✓	✓

# Innledning

Gratulerer med kjøpet, og velkommen til Philips!

Hvis du vil dra full nytte av støtten som Philips tilbyr, kan du registrere produktet ditt på [www.philips.com/welcome](http://www.philips.com/welcome).

## Generell beskrivelse

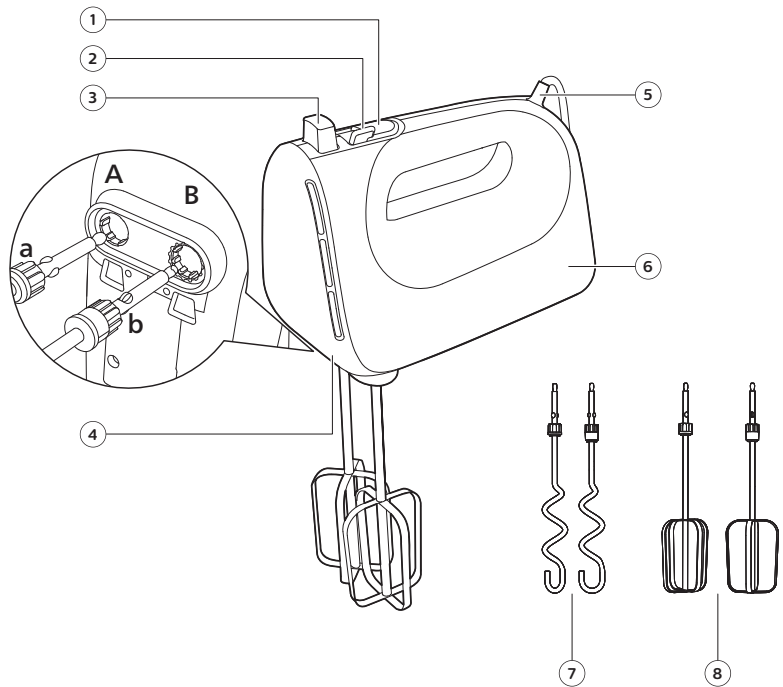

- 1 Turbo-knapp  
Trykk på og hold nede for å nå maksimal hastighet
- 2 Hastighetskontroll  
0: AV-posisjon  
1–5: hastighetsinnstilling
- 3 Utløserknapp  
Trykk for å løse ut vispene eller deigkrokene
- 4 Hull for vispene og deigkrokene
- 5 Nettledning
- 6 Hovedenhet
- 7 To deigkroker
- 8 To visper

## Før bruk første gang

Før førstegangsbruk må du vaske apparatet og tilbehøret med varmt såpevann. Skyll dem grundig og tørk dem helt før montering.

Unngå å plassere den i nærheten av varmekilder, vann eller brennbare materialer.

## Bruke apparatet

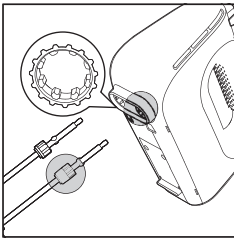

1 Sett vispene eller eltekrokene inn i hovedenheten.

**Sett vispen eller eltekroken med plastkragen inn i den større åpningen.**

2 Sett støpselet inn i stikkontakten.

3 Ha ingrediensene i en bolle.

**Se anbefalte mengder og behandlingstider i avsnittet «Behandlingsmengder og behandlingstider».**

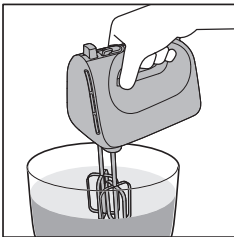

4 Senk vispene eller eltekrokene ned i ingrediensene.

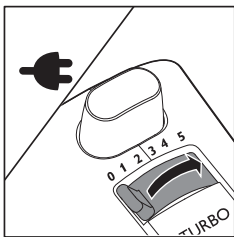

5 Still hastighetskontrollen til ønsket hastighetsinnstilling for å slå på apparatet.

**Begynn å blande på lav hastighet for å unngå sprut. Øk til høyere hastighet etter hvert.**

Du kan trykke på turbo-knappen for å mikse raskere eller øke hastigheten under tunge oppgaver, f.eks. elting av gjærdeig.

Hvis du vil stoppe miksingene en stund, sett hastighetskontrollen til «0» for å slå av apparatet.

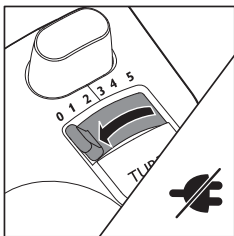



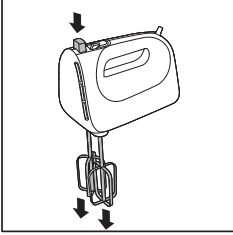







6 Når du er ferdig med å mikse, setter du hastighetskontrollen til «0» og trekker ut støpselet fra apparatet.

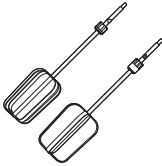

7 For å løsne vispene eller eltekrokene, trykk på utløserknappen.

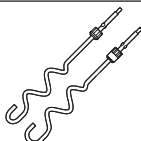
## Bearbeide mengder og bearbeidingstider

**Ikke overskrid maksimumsmengdene og tilberedningstidene som er angitt.**





		 Kg (MAX)		
		500 ml	6 min	5
		8 x	2 min	5
		750 g	3 min	1-5
		 1000 g	5 min	5
		 720 g		

# Rengjøring og vedlikehold

**Trekk alltid ut støpselet før du rengjør apparatet.**

**Motorenheten må aldri senkes ned i vann eller skylles under springen.**

- 1 Rengjør vispene og eltekroene i varmt vann med oppvaskmiddel, eller i oppvaskmaskinen.
- 2 Rengjør motorenheten med en fuktig klut.

			
	✗	✗	✓
	✓	✓	✓

## Wstęp

Gratulujemy zakupu i witamy w firmie Philips!

Aby w pełni skorzystać z obsługi świadczonej przez firmę Philips, należy zarejestrować zakupiony produkt na stronie [www.philips.com/welcome](http://www.philips.com/welcome).

## Opis ogólny

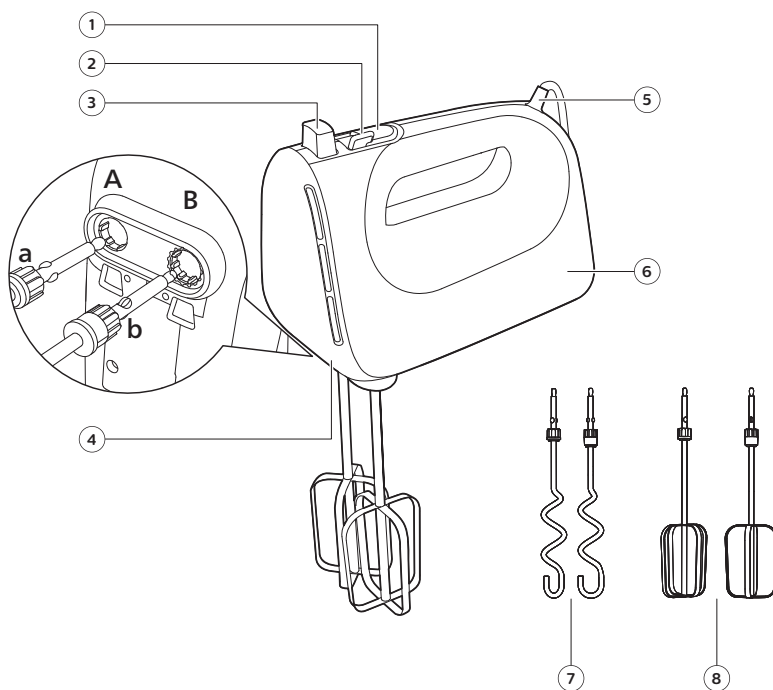

- 1 Przycisk turbo  
Naciśnij i przytrzymaj, aby osiągnąć maksymalną prędkość.
- 2 Regulacja prędkości  
0: Pozycja wyłączenia  
1-5: ustawienie prędkości
- 3 Przycisk wysuwający  
Naciśnij, aby zwolnić końcówki do ubijania piany lub końcówki do wyrabiania ciasta
- 4 Otwór do umieszczania końcówek do ubijania piany i końcówek do wyrabiania ciasta
- 5 Przewód zasilający
- 6 Jednostka centralna
- 7 Dwie końcówki do wyrabiania ciasta
- 8 Dwie końcówki do ubijania piany

## Przed pierwszym użyciem

Przed pierwszym użyciem dokładnie umyj urządzenie i akcesoria przy użyciu ciepłej wody z mydłem. Dokładnie opłucz elementy i pozostaw do całkowitego wysuszenia przez ponownym złożeniem.

Nie ustawiaj urządzenia blisko źródeł ciepła, wody lub materiałów łatwopalnych.

## Zasady używania urządzenia

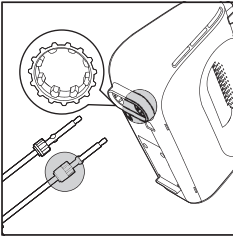

- 1 Włóż końcówki do ubijania piany lub haki do ugniatania do urządzenia głównego.

**Włóż końcówkę do ubijania piany lub hak do ugniatania z plastikową nasadką do większego otworu.**

- 2 Włóż wtyczkę do gniazdka elektrycznego.
- 3 Włóż składniki do pojemnika.

**Zobacz zalecane ilości i czasy przetwarzania w sekcji „Ilości przetwarzania i czasy przetwarzania”.**

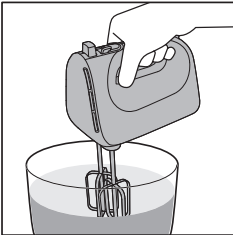

- 4 Włóż końcówki do ubijania piany lub haki do ugniatania do składników.

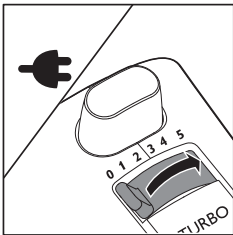

- 5 Ustaw regulator prędkości na żądaną prędkość, aby włączyć urządzenie.

**Rozpocznij mieszanie na niskich obrotach, aby uniknąć rozpryskiwania. Później zwiększ prędkość.**

Możesz nacisnąć przycisk turbo, aby szybciej mieszać lub zwiększyć prędkość podczas wykonywania ciężkich zadań, np. wyrabiania ciasta drożdżowego.

Jeśli chcesz na chwilę przerwać mieszanie, ustaw regulator prędkości na „0”, aby wyłączyć urządzenie.

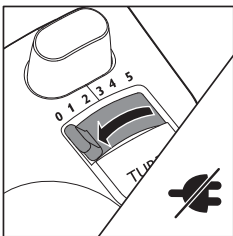

- 6 Po zakończeniu mieszania ustaw regulator prędkości na „0” i odłącz urządzenie od zasilania.



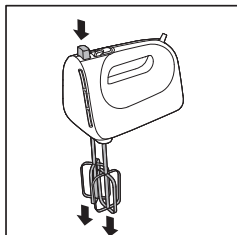









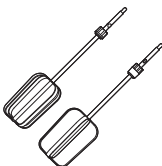

7 Aby zwolnić ubijaki lub haki do ugniatania, naciśnij przycisk wysuwania.

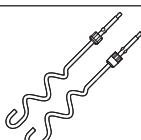
## Ilości składników i czas przygotowania (miksowanie)

Nie przekraczaj maksymalnej ilości składników ani podanych czasów przygotowania.





		 Kg (MAX)		
		500 ml	6 min	5
		8 x	2 min	5
		750 g	3 min	1-5
			5 min	5
				

## Czyszczenie i konserwacja

Zanim zaczniesz czyścić urządzenie, zawsze wyjmij wtyczkę z gniazdka elektrycznego.

Nigdy nie zanurzaj części silnikowej w wodzie ani nie opłukuj pod bieżącą wodą.

- 1 Umyj końcówki do ubijania piany i końcówki do wyrabiania ciasta w ciepłej wodzie z dodatkiem niewielkiej ilości płynu do mycia naczyń lub w zmywarce.
- 2 Wytrzyj część silnikową wilgotną szmatką.

			
	✗	✗	✓
	✓	✓	✓

# Introdução

Parabéns pela sua aquisição e bem-vindo à Philips!

Para tirar o máximo partido da assistência oferecida pela Philips, registre o seu produto em: [www.philips.com/welcome](http://www.philips.com/welcome).

## Descrição geral

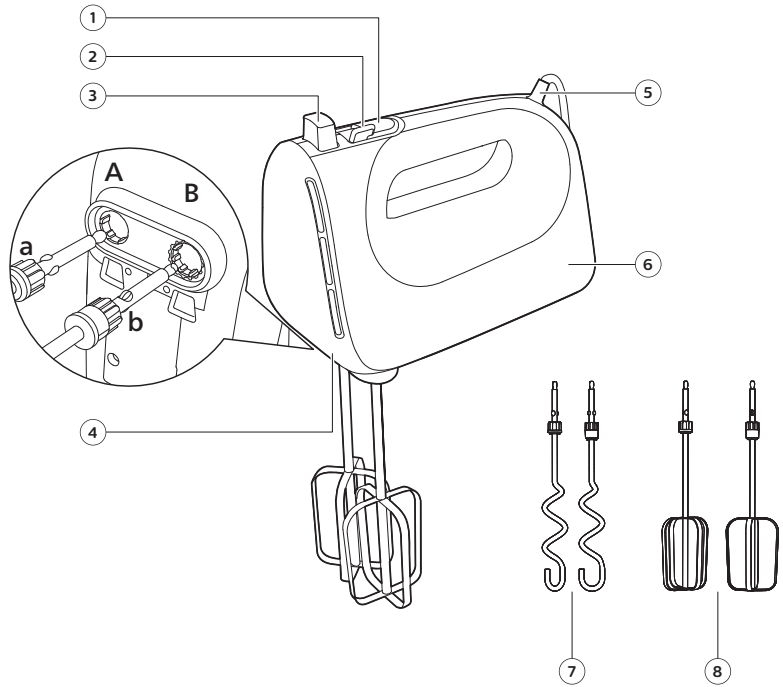

- 1 Botão turbo  
Manter premido para alcançar a velocidade máxima
- 2 Controlo de velocidade  
0: posição "OFF"  
1-5: definições de velocidade
- 3 Botão de ejeção  
Prima para soltar as varas de bater ou as pás de amassar
- 4 Orifício para as varas de bater e pás de amassar
- 5 Cabo de alimentação
- 6 Componente principal
- 7 Duas pás de amassar
- 8 Duas varas

## Antes da primeira utilização

Antes da primeira utilização, lave o aparelho e respetivos acessórios com água morna e detergente. Enxague-os cuidadosamente e seque-os completamente antes de montar.

Evite colocá-la perto de fontes de calor, água ou materiais inflamáveis.

## Utilizar o aparelho

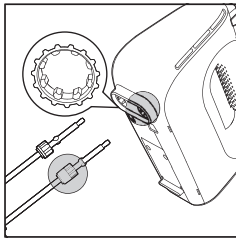

- 1 Introduza as varas ou as pás para amassar na unidade principal.

**Introduza a vara ou a pá para amassar com o anel de plástico na abertura maior.**

- 2 Ligue a ficha à tomada eléctrica.
- 3 Coloque os ingredientes numa taça.

**Consulte as quantidades e os tempos de processamento recomendados na secção "Quantidades e tempo de processamento".**

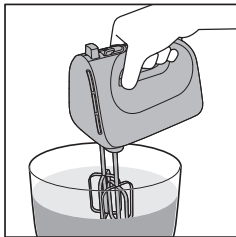

- 4 Coloque as varas ou pás para amassar nos ingredientes.

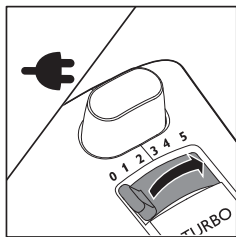

- 5 Regule o controlo de velocidade para a definição de velocidade pretendida para ligar o aparelho.

**Comece a misturar em velocidade baixa para evitar salpicos. Mude para uma velocidade mais elevada mais tarde.**

Pode premir o botão turbo para misturar mais rapidamente ou aumentar a velocidade durante tarefas exigentes, por exemplo, amassar massa com fermento.

Se quiser parar de misturar, defina o controlo de velocidade para "0" para desligar o aparelho.

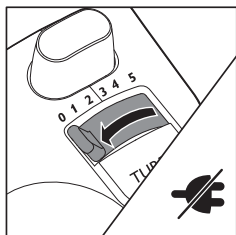



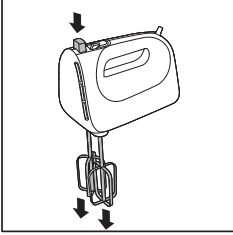





- 6 Quando terminar de misturar, defina o controlo de velocidade para "0" e desligue o aparelho da corrente.

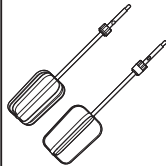

7 Para soltar as varas ou as pás para amassar, prima o botão de ejeção.

## Quantidades e tempos de processamento

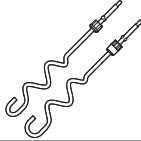
Não exceda as quantidades nem os tempos de processamento máximos indicados.





		 Kg (MAX)		
		500 ml	6 min	5
		 x8	2 min	5
		750 g	3 min	1-5
		1000 g	5 min	5
		720 g		

# Limpeza e manutenção

**Desligue sempre o aparelho antes de o limpar.**

**Nunca mergulhe o motor em água nem o enxague em água corrente.**

- 1 Lave as varas e as pás para amassar com água quente e um pouco de detergente líquido, ou coloque-as na máquina de lavar loiça.
- 2 Limpe o motor com um pano húmido.

			
	✗	✗	✓
	✓	✓	✓

# Introducere

Felicitări pentru achiziție și bun venit la Philips!

Pentru a beneficia pe deplin de asistența oferită de Philips, înregistrează-ți produsul la [www.philips.com/welcome](http://www.philips.com/welcome).

## Descriere generală

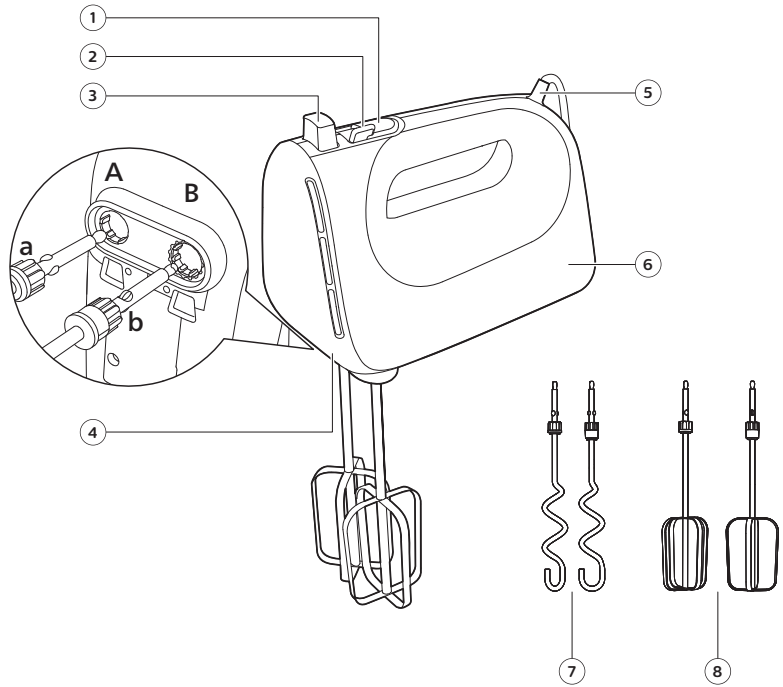

- 1 Butonul turbo  
Apasă-l și menține-l apăsat pentru a crește viteza
- 2 Control al vitezei  
0: Poziția OPRIT  
1-5: setare de viteză
- 3 Buton detașare  
Apasă-l pentru a elibera paletele sau spiralele pentru aluat
- 4 Orificiu pentru paletele și spiralele pentru aluat
- 5 Cablu de alimentare
- 6 Unitatea principală
- 7 Două spirale pentru aluat
- 8 Două palete

## Înainte de prima utilizare

Înainte de prima utilizare, spală aparatul și accesoriile cu apă caldă cu săpun. Clătește-le bine și usucă-le complet înainte de asamblare.

Evită amplasarea acestuia în apropierea surselor de căldură, a apei sau a materialelor inflamabile.

## Utilizarea aparatului

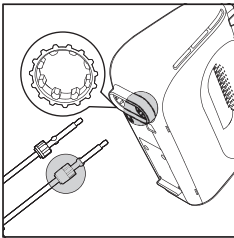

- 1 Introdu paletelile sau spiralele pentru aluat în unitatea principală.

**Introdu paleta sau spirala pentru aluat cu manșonul de plastic în orificiul mai mare.**

- 2 Introdu ștecărul în priză.

- 3 Pune ingredientele într-un castron.

**Consultă cantitățile și timpii de procesare recomandați în secțiunea „Cantități de procesare și timpi de procesare”.**

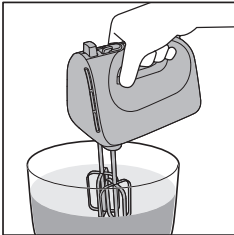

- 4 Coboară paletelile sau spiralele pentru aluat în ingrediente.

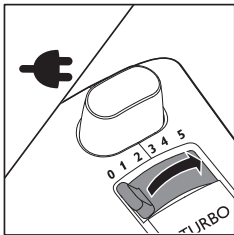

- 5 Setează butonul de viteză la viteza dorită pentru a porni aparatul.

**Începe să mixezi la viteză mică pentru a evita stropirea. Comută mai târziu la o viteză mai mare.**

Poți apăsa butonul turbo pentru a mixa mai repede sau pentru a mări viteza în timpul sarcinilor grele, de ex., frământarea aluatului dospit.

Dacă dorești să oprești mixarea pentru un timp, setează butonul vitezei la „0” pentru a opri aparatul.

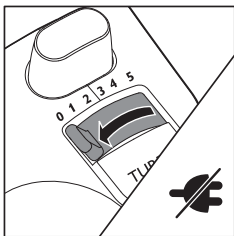

- 6 După ce ai terminat de mixat, setează butonul vitezei la „0” și scoate aparatul din priză.



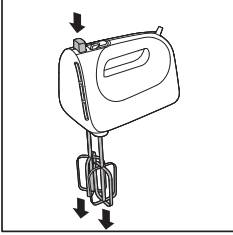









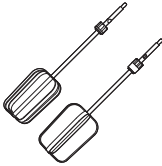

- 7 Pentru a elibera paletele sau spiralele pentru aluat, apăsați butonul de detașare.

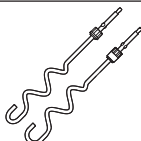
## Cantități și timpi de procesare

**Nu depăși cantitățile și duratele de procesare maxime indicate.**





		 Kg (MAX)		
		500 ml	6 min	5
		8 x	2 min	5
		750 g	3 min	1-5
		 1000 g	5 min	5
		720 g		

## Curățare și întreținere

**Scoate întotdeauna aparatul din priză înainte de a-l curăța.**

**Nu introdu blocul motor în apă și nici nu îl clăți la robinet.**

- 1 Curăță paletele și spiralele pentru aluat în apă fierbinte cu puțin detergent lichid sau într-o mașină de spălat vase.
- 2 Curăță blocul motor cu o cârpă umedă.

			
	✗	✗	✓
	✓	✓	✓

# Hyrje

Urime për blerjen dhe mirë se vini te Philips!

Për të përfutur plotësisht nga mbështetja që ofron Philips, regjistroni produktin në faqen [www.philips.com/welcome](http://www.philips.com/welcome).

## Përshkrim i përgjithshëm

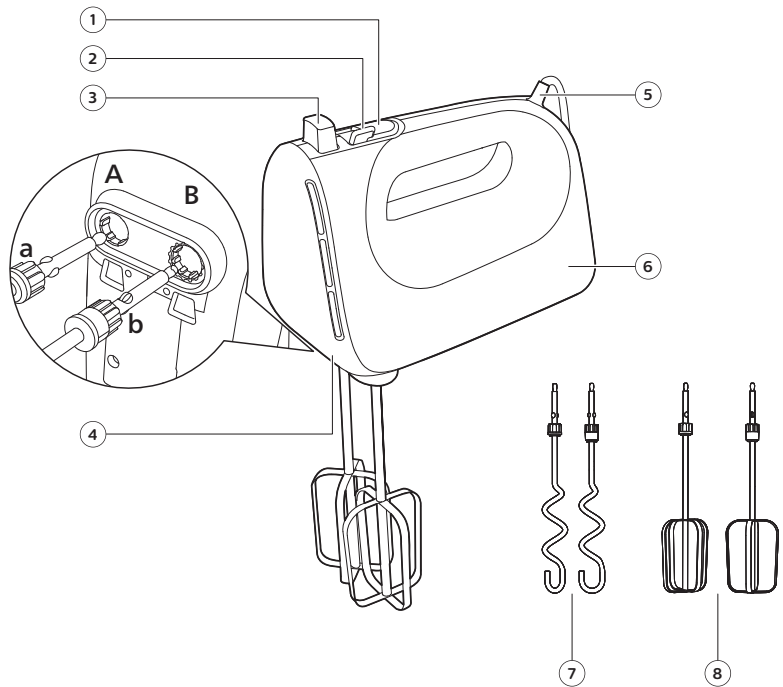

- 1 Butoni "Turbo"  
Shtypeni e mbajeni për të arritur shpejtësinë maksimale
- 2 Kontrolli i shpejtësisë  
0: Pozicioni "FIKUR"  
1-5: cilësimi i shpejtësisë
- 3 Butoni "Eject"  
Shtypeni për të çliruar rrahëset ose kapëset e brumit
- 4 Vrimë për rrahëset dhe kapëset e brumit
- 5 Kordoni elektrik
- 6 Njësia kryesore
- 7 Dy kapëse brumi
- 8 Dy rrahëse

## Përpara përdorimit të parë

Para përdorimit të parë, lani pajisjen dhe aksesoret me ujë të ngrohtë me sapun. Shpëlajini tërësisht dhe thajini plotësisht përpara se t'i montoni.

Shmangni vendosjen pranë burimeve të nxehtësisë, ujit apo materialeve të ndezshme.

## Përdorimi i pajisjes

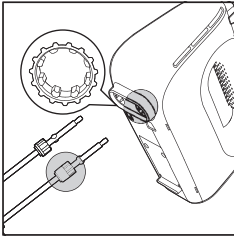

- 1 Futni rrahëset ose grepat e trazimit në njësinë kryesore.

**Fusni rrahësen ose grepin e trazimit me qafën plastike në vrimën më të madhe.**

- 2 Futni spinën në prizë.
- 3 Hidhni përbërësit në një tas.

**Shikoni sasi të rekomanduara dhe kohët e përpunimit në seksionin "Sasi të dhe koha e përpunimit".**

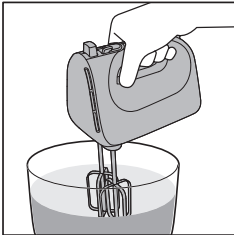

- 4 Ulni rrahëset ose grepat e trazimit mbi përbërës.

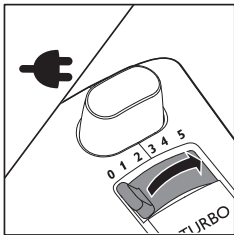

- 5 Caktoni kontrollin e shpejtësinë në nivelin e dëshiruar, për të ndezur pajisjen.

**Filloni të përzieni me shpejtësi të ulët për të shmangur spërkatjen. Kaloni në një shpejtësi më të lartë më vonë.**

Mund të shtypni butonin e turbos për të përzier më shpejt ose për të rritur shpejtësinë gjatë detyrave të rënda, p.sh. zënies së brumit me maja.

Nëse dëshironi të ndaloni përzierjen për njëfarë kohe, vendosni kontrollin e shpejtësisë në "0" për të fikur pajisjen.

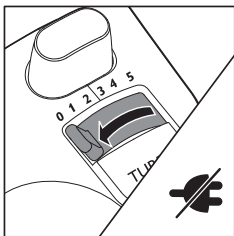



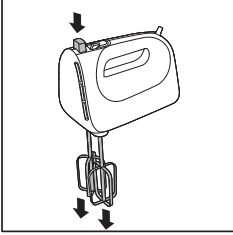







- 6 Kur të keni përfunduar përzierjen, caktoni kontrollin e shpejtësisë në "0" dhe shkëputni pajisjen.

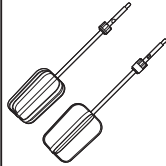

7 Për të liruar rrahëset ose grepat e trazimit, shtypni butonin e nxjerrjes.

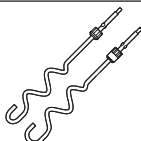
## Sasitë dhe koha e përpunimit

Mos i tejkaloni sasitë dhe kohët e përcaktuara maksimale të përzierjes.





		 Kg (MAX)		
		500 ml	6 min	5
		8 x	2 min	5
		750 g	3 min	1-5
		 1000 g	5 min	5
		720 g		

## Pastrimi dhe mirëmbajtja

**Hiqeni gjithmonë pajisjen nga priza përpara se ta pastroni.**

**Mos e zhytni kurrë njësinë e motorit në ujë as mos e shpëlani në rubinet.**

- 1 Pastrojini rrahëset dhe greap trazimit në ujë të ngrohtë me pak lëng larës ose në enëlarëse.
- 2 Pastrojini njësinë e motorit me një leckë të lagur.

			
	✗	✗	✓
	✓	✓	✓

## Uvod

Čestitamo vam za nakup in dobrodošli pri Philipsu!

Da bi izkoristili vse prednosti Philipsove podpore, izdelek registrirajte na [www.philips.com/welcome](http://www.philips.com/welcome).

## Splošni opis

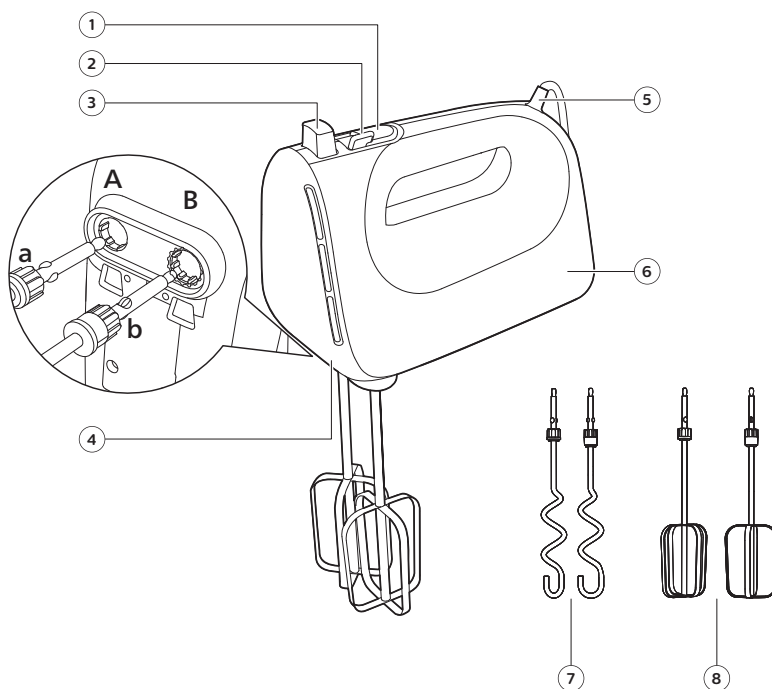

- 1 Gumb Turbo  
Pridržite, da dosežete najvišjo hitrost
- 2 Regulator hitrosti  
0: IZKLOPLJENI položaj  
1–5: nastavitve hitrosti
- 3 Gumb za izmet  
Pritisnite, da sprostite metlici ali kavlja za gnetenje testa
- 4 Reža za metlici in kavlja za gnetenje testa
- 5 Napajalni kabel
- 6 Glavna enota
- 7 Dva kavlja za gnetenje testa
- 8 Dve metlici

## Pred prvo uporabo

Pred prvo uporabo aparat in dodatke očistite s toplo milnico. Preden ga sestavite, aparat temeljito sperite in popolnoma osušite.

Ne postavljajte ga v bližino virov toplote, vode ali vnetljivih materialov.

## Uporaba aparata

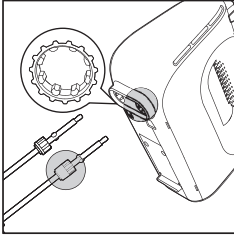

- 1 Metlici ali kavlja za gnetenje vstavite v glavno enoto.

**Metlico ali kavelj za gnetenje s plastičnim obročkom vstavite v večjo odprtino.**

- 2 Vtič priključite v stensko vtičnico.  
3 Sestavine dajte v posodo.

**Priporočene količine in čase obdelave si oglejte v razdelku "Količine in časi obdelave".**

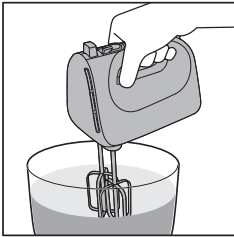

- 4 Metlici ali kavlja za gnetenje pogreznite v sestavine.

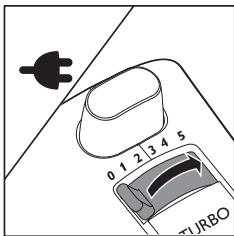

- 5 Regulator hitrosti nastavite na želeno hitrost, da vklopite aparat.

**Mešati začnite pri manjši hitrosti, da se izognete pljuskanju. Pozneje preklopite na večjo hitrost.**

Za hitrejše mešanje ali za večjo hitrost med zahtevnejšimi opravili, na primer pri gnetenju kvašenega testa, pritisnite gumb Turbo.

Če mešanje želite začasno prekiniti, regulator hitrosti nastavite na "0", da izklopite aparat.

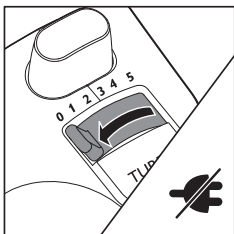

- 6 Ko končate z mešanjem, regulator hitrosti nastavite na '0' in aparat izključite iz električnega omrežja.



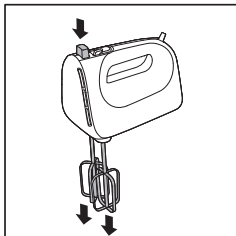







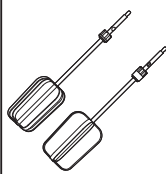

7 Pritisnite gumb za izmet, da sprostite metlici ali kavlja za gnetenje.

## Količine in časi obdelave

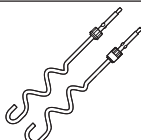
Ne prekoračite navedenih maksimalnih količin in časov obdelave.





		 Kg (MAX)		
		500 ml	6 min	5
		8 x	2 min	5
		750 g	3 min	1-5
		1000 g	5 min	5
		720 g		

# Čiščenje in vzdrževanje

**Aparat pred čiščenjem izključite iz električnega omrežja.**

**Motorne enote nikoli ne potaplajte v vodo, niti je ne izpirajte pod vodnim curkom.**

- 1 Metlici in kavlja za gnetenje pomijte v topli vodi z nekaj tekočega čistila ali v pomivalnem stroju.
- 2 Motorno enoto očistite z vlažno krpo.

			
	✗	✗	✓
	✓	✓	✓

# Úvod

Blahoželáme vám ku kúpe a vítame vás medzi používateľmi produktov spoločnosti Philips.

Ak chcete naplno využiť podporu ponúkanú spoločnosťou Philips, zaregistrujte svoj produkt na lokalite [www.philips.com/welcome](http://www.philips.com/welcome).

## Opis zariadenia

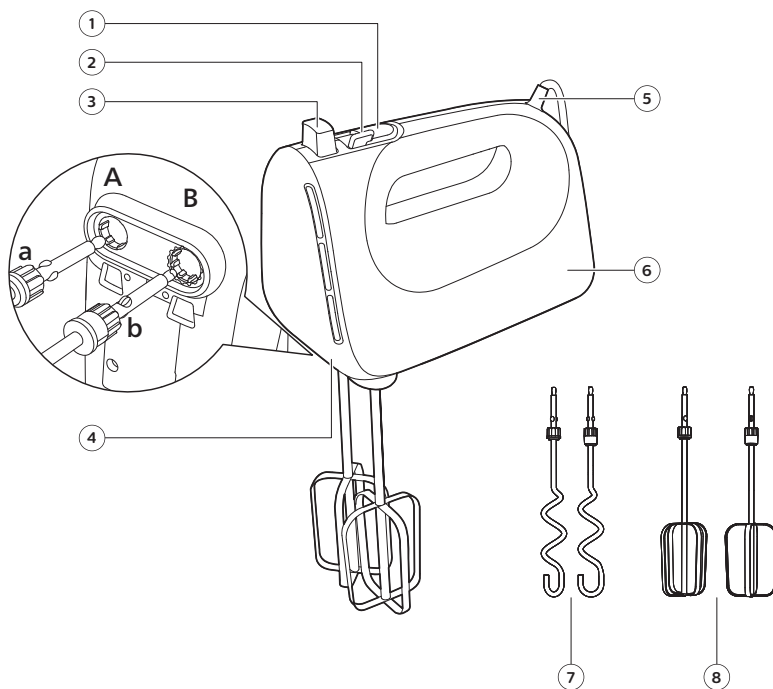

- 1 Tlačidlo Turbo  
Stlačením a podržaním dosiahnete maximálnu rýchlosť
- 2 Regulácia rýchlosti  
0: poloha VYP.  
1 – 5: nastavenie rýchlosti
- 3 Tlačidlo na uvoľnenie nadstavcov  
Stlačením uvoľníte šľahacie nadstavce alebo háky na cesto
- 4 Otvor pre šľahacie nadstavce a háky na cesto
- 5 Sieťový kábel
- 6 Hlavná jednotka
- 7 Dva háky na cesto
- 8 Dva šľahacie nadstavce

## Pred prvým použitím

Pred prvým použitím umyte zariadenie a príslušenstvo teplou mydlovou vodou. Pred zostavením ich dôkladne opláchnite a úplne vysušte. Neumiestňujte ho do blízkosti zdrojov tepla, vody alebo horľavých materiálov.

## Používanie spotrebiča

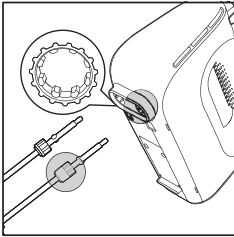

- 1 Vložte šľahacie nadstavce alebo háky na miesenie do hlavnej jednotky.

**Vložte šľahací nadstavec alebo hák na miesenie s plastovým krúžkom do väčšieho otvoru.**

- 2 Pripojte zástrčku do zásuvky na stene.  
3 Do misky vložte suroviny.

**Pozrite si odporúčané množstvá a časy spracovania v časti „Spracované množstvá a čas spracovania“.**

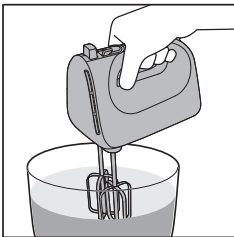

- 4 Šľahacie nadstavce alebo háky na miesenie ponorte do prísad.

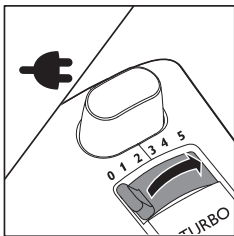

- 5 Nastavte reguláciu rýchlosti na požadované nastavenie rýchlosti a zapnite zariadenie.

**Začnite mixovať pri nízkej rýchlosti, aby ste zabránili vyšplechovaniu. Neskôr prejdite na vyššiu rýchlosť.**

Môžete stlačiť tlačidlo Turbo na rýchlejšie mixovanie alebo zvýšiť rýchlosť počas náročných úloh, napríklad miesenia kysnutého cesta.

Ak chcete na chvíľu prestať mixovať, nastavte reguláciu rýchlosti na „0“ a vypnite zariadenie.

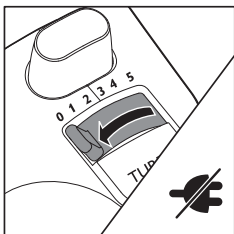



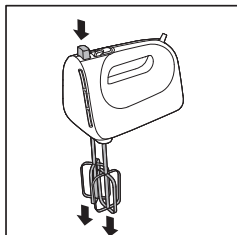







- 6 Po skončení mixovania nastavte reguláciu rýchlosti na „0“ a odpojte zariadenie.

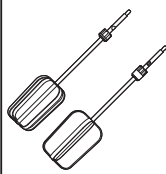

- 7 Stlačením tlačidla na uvoľnenie nastavcov uvoľnite šlahacie nastavce alebo háky na miesenie.

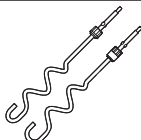
## Spracované množstvá a čas spracovania

**Neprekráčajte maximálne uvedené množstvá a doby spracovania.**





		 Kg (MAX)		
		500 ml	6 min	5
		8 x	2 min	5
		750 g	3 min	1-5
		 1000 g	5 min	5
		720 g		

## Čistenie a údržba

**Pred začatím čistenia vždy odpojte zariadenie zo siete.**

**Pohonnú jednotku nikdy neponárajte do vody ani neumývajte pod tečúcou vodou.**

- 1 Šľahacie nadstavce a háky na miesenie umyte v teplej vode s prídavkom saponátu alebo v umývačke na riad.
- 2 Pohonnú jednotku očistite navlhčenou tkaninou.

			
	✗	✗	✓
	✓	✓	✓

## Uvod

Čestitamo na kupovini i dobro došli u Philips!

Da biste najbolje iskoristili podršku koju nudi kompanija Philips, registrujte svoj proizvod na: [www.philips.com/welcome](http://www.philips.com/welcome).

## Opšti opis

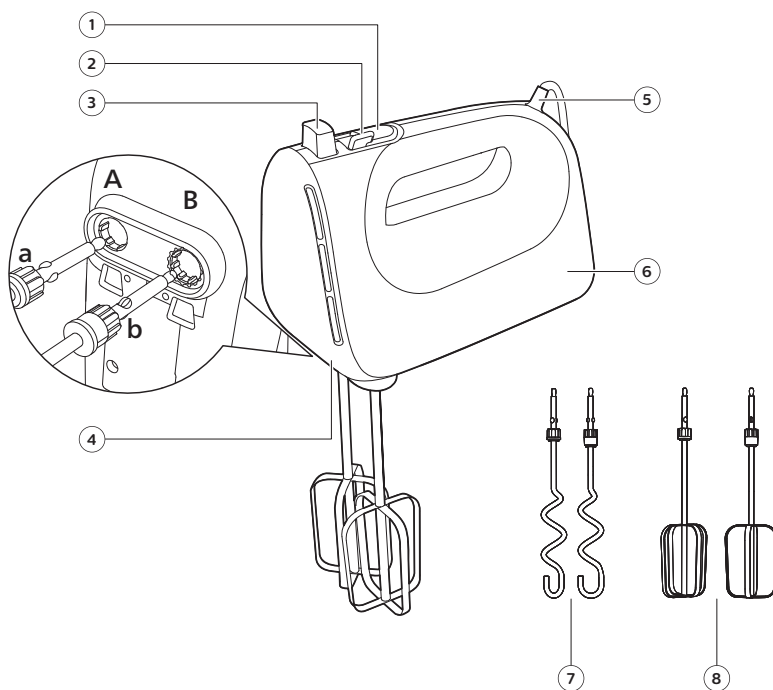

- 1 Dugme turbo  
Pritisnite i zadržite da biste postigli maksimalnu brzinu
- 2 Kontrola brzine  
0: Položaj ISKLJ.  
1–5: postavka brzine
- 3 Dugme za izbacivanje  
Pritisnite da biste oslobodili dodatke za mućenje ili spiralne dodatke za testo
- 4 Otvor za dodatke za mućenje i spiralne dodatke za testo
- 5 Kabl za napajanje
- 6 Glavna jedinica
- 7 Dva spiralna dodatka za testo
- 8 Dva dodatka za mućenje

## Pre prve upotrebe

Pre prve upotrebe, operite aparat i dodatke toplom vodom sa sapunom. Temeljno ih isperite i potpuno osušite pre sastavljanja. Izbegavajte postavljanje blizu izvora toplote, vode ili zapaljivih materijala.

## Upotreba aparata

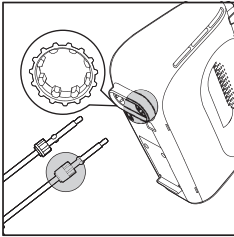

- 1 Spustite dodatke za mućenje ili spiralne dodatke za testo u glavnu jedinicu.

**Dodatak za mućenje ili spiralni dodatak za testo sa plastičnim naglavkom umetnite u veći prorez.**

- 2 Uključite utikač u zidnu utičnicu.  
3 Stavite sastojke u činiju.

**Pogledajte preporučene količine i vremena obrade u odeljku „Količine i vremena obrade“.**

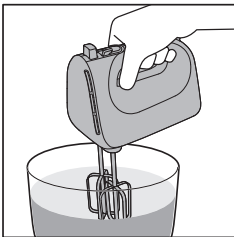

- 4 Spustite dodatke za mućenje ili spiralne dodatke za testo u sastojke.

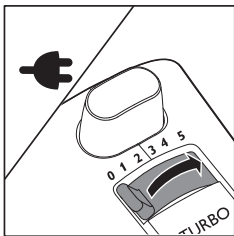

- 5 Postavite regulator brzine na željenu postavku da biste uključili aparat.

**Počnite sa mućenjem na maloj brzini da biste izbegli prskanje. Kasnije prebacite na veću brzinu.**

Možete pritisnuti turbo dugme da biste mutili brže ili povećali brzinu tokom zahtevnijih zadataka, npr. mešenja testa sa kvascem.

Ako želite da na trenutak prekinete mućenje, postavite regulator brzine na „0“ da biste isključili aparat.

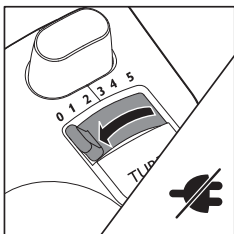

- 6 Kada završite sa mućenjem, postavite regulator brzine na „0“ i isključite aparat iz struje.



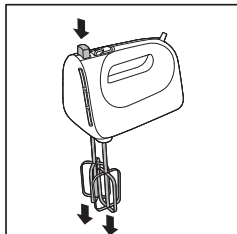









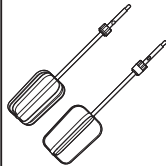

- 7 Da biste oslobodili dodatke za mućenje ili spiralne dodatke za testo, pritisnite dugme za izbacivanje.

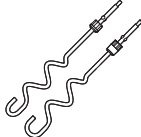
## Količine za obradu i vreme obrade

Nemojte da prekoračujete maksimalne količine i vremena obrade koji su navedeni.





		 Kg (MAX)		
		500 ml	6 min	5
		 x8	2 min	5
		750 g	3 min	1-5
		 1000 g	5 min	5
		720 g		

## Čišćenje i održavanje

**Aparat uvek isključite iz napajanja pre nego što počnete sa čišćenjem.**

**Jedinicu motora nikada me uranjajte u vodu i ne perite je ispod slavine.**

- 1 Dodatke za mućenje i spiralne dodatke za testo čistite u toploj vodi sa malo deterdženta ili u mašini za pranje sudova.
- 2 Jedinicu motora čistite vlažnom krpom.

			
	✗	✗	✓
	✓	✓	✓

# Johdanto

Onnittelut ostoksestasi ja tervetuloa Philips-tuotteen käyttäjäksi!  
Hyödynnä Philipsin tukipalveluita rekisteröimällä tuotteesi osoitteessa  
[www.Philips.com/welcome](http://www.Philips.com/welcome).

# Yleiskuvaus

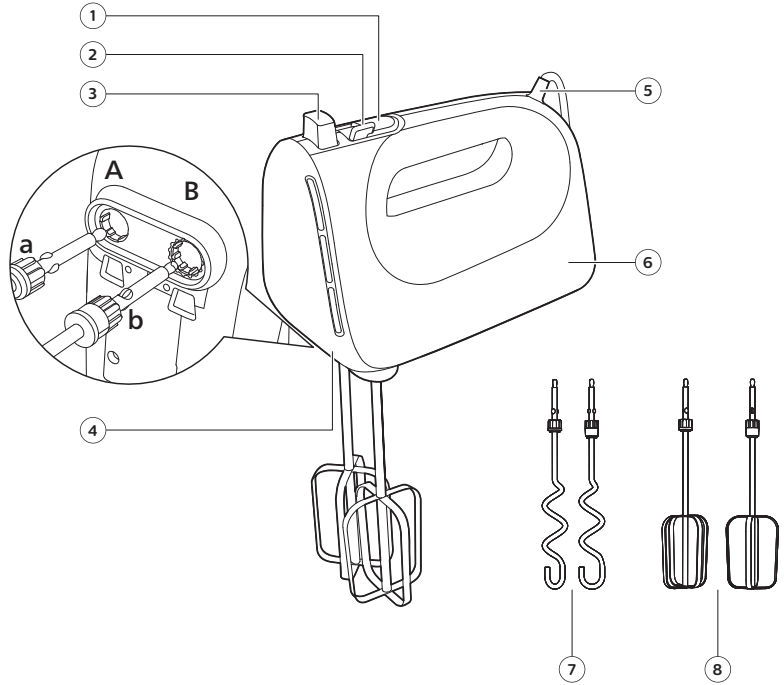

- 1 Turbopainike  
Voit ottaa suurimman nopeuden käyttöön pitämällä painiketta painettuna
- 2 Nopeuden säätö  
0: OFF-asento  
1–5: nopeusasetus
- 3 Poistopainike  
Painallus irrottaa vispilät tai taikinakoukut
- 4 Vispilöiden ja taikinakoukkujen kiinnitysaukko
- 5 Virtajohto
- 6 Päälaite
- 7 Kaksi taikinakoukku
- 8 Kaksi vispilää

## Ennen käyttöönottoa

Pese laite ja lisävarusteet lämpimällä saippuvedellä ennen ensimmäistä käyttökertaa. Huuhtelee osat huolellisesti ja kuivaa ne täysin ennen kokoamista. Vältä sijoittamista sitä lämmönlähteiden, veden tai herkästi syttyvien materiaalien lähelle.

## Käyttö

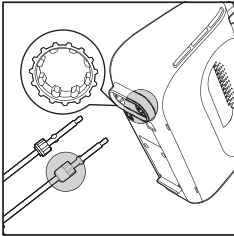

- 1 Kiinnitä vispilät tai taikinakoukut päälaitteeseen.

**Työnnä muovirenkaalla varustettu vispilä tai taikinakoukku suurempaan aukkoon.**

- 2 Työnnä pistoke pistorasiaan.
- 3 Mittaa aineet kulhoon.

**Katso suositellut määrät ja käsittelyajat osiosta "Käsiteltävät määrät ja valmistusajat".**

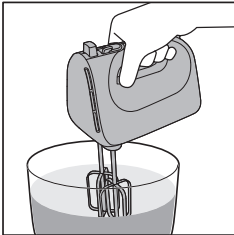

- 4 Laske vispilät tai taikinakoukut aineiden joukkoon.

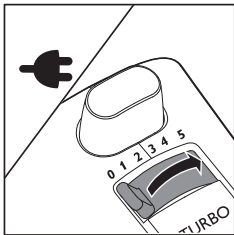

- 5 Valitse nopeus ja käynnistä laite.

**Aloita vatkaaminen pienimmällä nopeudella roiskumisen välttämiseksi. Vaihda myöhemmin suuremmalle nopeudelle.**

Paina turbopainiketta, kun haluat lisätä vatkauksen nopeutta tai tarvitset enemmän voimaa esimerkiksi leipätaikinan vaivaamiseen.

Jos haluat lopettaa vatkauksen hetkeksi, valitse nopeusasetukseksi 0, jolloin laitteen virta katkeaa.

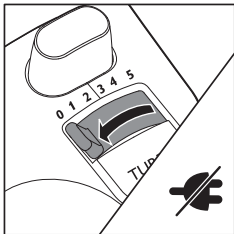



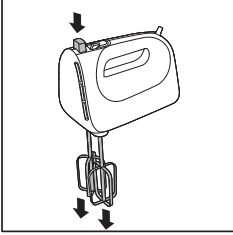







- 6 Kun olet lopettanut vatkauksen, valitse nopeudeksi 0 ja irrota laitteen pistoke pistorasiasta.

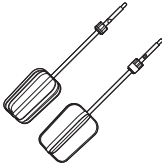

7 Irrota vispilät tai taikinakoukut painamalla poistopainiketta.

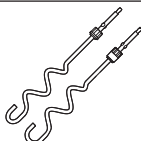
## Käsiteltävät määrät ja valmistusaika

Älä ylitä annettuja määriä ja valmistusaikoja.





		 Kg (MAX)		
		500 ml	6 min	5
		☉ x8	2 min	5
		750 g	3 min	1-5
		 1000 g	5 min	5
		 720 g		

# Puhdistus ja hoito

**Irrota aina pistoke pistorasiasta ennen laitteen puhdistamista.**

**Älä upota runkoa veteen tai huuhtele sitä vesihanalla.**

- 1 Pese vispilät ja taikinakoukut lämpimällä vedellä ja astianpesuaineella tai astianpesukoneessa.
- 2 Pyyhi runko puhtaaksi kostealla liinalla.

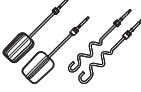
			
	✗	✗	✓
	✓	✓	✓

# Introduktion

Vi gratulerar till ditt köp och hälsar dig välkommen till Philips!

Genom att registrera din produkt på [www.philips.com/welcome](http://www.philips.com/welcome) kan du dra nytta av Philips support.

## Allmän beskrivning

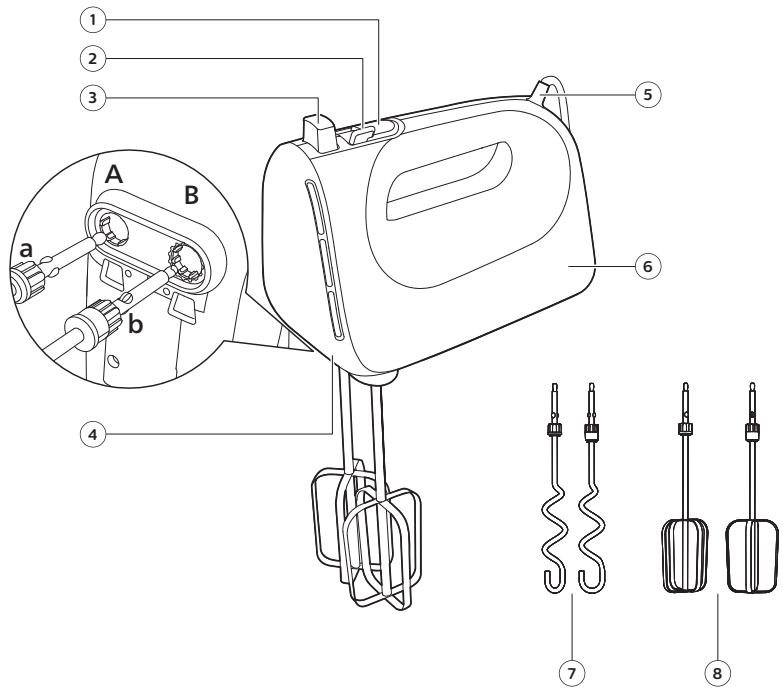

- 1 Turboknapp  
Håll intryckt för att nå maximal hastighet
- 2 Hastighetskontroll  
0: AV-läge  
1–5: hastighetsinställning
- 3 Frigöringsknapp  
Håll intryckt för att frigöra visparna och degkrokarna
- 4 Hål för vispar och degkrokar
- 5 Nätkabel
- 6 Huvudenhet
- 7 Två degkrokar
- 8 Två vispar

## Före första användningen

Diska apparaten och tillbehören i varmt tvålatten före första användningen. Skölj dem noggrant och torka dem helt innan du monterar ihop dem. Undvik att placera den nära värmekällor, vatten och lättantändliga material.

## Använda apparaten

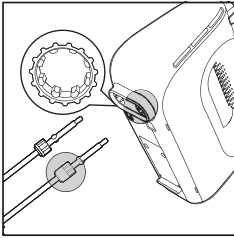

1 För in visparna eller degkrokarna i huvudenheten.

**För in vispen eller degkroken med plastkragen i den större öppningen.**

2 Sätt i kontakten i vägguttaget.

3 Lägg ingredienserna i en skål.

**Se rekommenderade mängder och bearbetningstider i avsnittet "Bearbetningsmängder och bearbetningstider".**

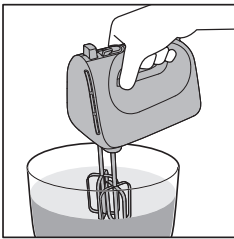

4 Sänk ned visparna eller degkrokarna i behållaren med ingredienser.

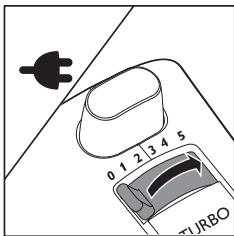

5 Ställ in hastighetsväljaren på önskad hastighetsinställning för att slå på apparaten.

**Börja vispa/knåda med en låg hastighet för att undvika stänk. Ändra till en högre hastighet senare.**

Du kan trycka på turboknappen för att vispa/knåda snabbare eller öka hastigheten vid tunga uppgifter, t.ex. när du knådar jästdeg.

Om du vill sluta vispa/knåda ett tag ställer du in hastighetsreglaget på "0" för att stänga av apparaten.

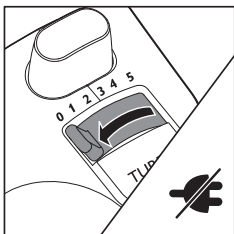

6 När du har vispat/knådat klart ställer du in hastighetsreglaget på "0" och kopplar ur apparaten.



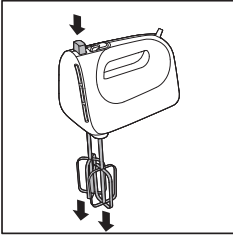









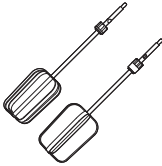

7 Tryck på frigöringsknappen för att lossa visparna eller degkrokarna.

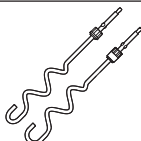
## Bearbetningsmängder och bearbetningstid

Överskrid inte de maximala mängderna och tillredningstiderna som anges.





		 Kg (MAX)		
		500 ml	6 min	5
		8 x	2 min	5
		750 g	3 min	1-5
		 1000 g	5 min	5
		 720 g		

# Rengöring och underhåll

**Dra alltid ur nätsladden innan du rengör apparaten.**

**Sänk aldrig ned motorenheten i vatten och skölj den inte under kranen.**

- 1 Rengör visparna och degkrokarna i varmt vatten med lite diskmedel eller i diskmaskinen.
- 2 Gör ren motorenheten med en fuktig trasa.

			
	✗	✗	✓
	✓	✓	✓

## Giriş

Satın alma tercihiniz için teşekkür ederiz, Philips'e hoş geldiniz!  
Philips'in sunduğu destekten tam olarak yararlanmak için ürününüzü  
[www.philips.com/welcome](http://www.philips.com/welcome) adresinde kaydedtirin.

## Genel açıklama

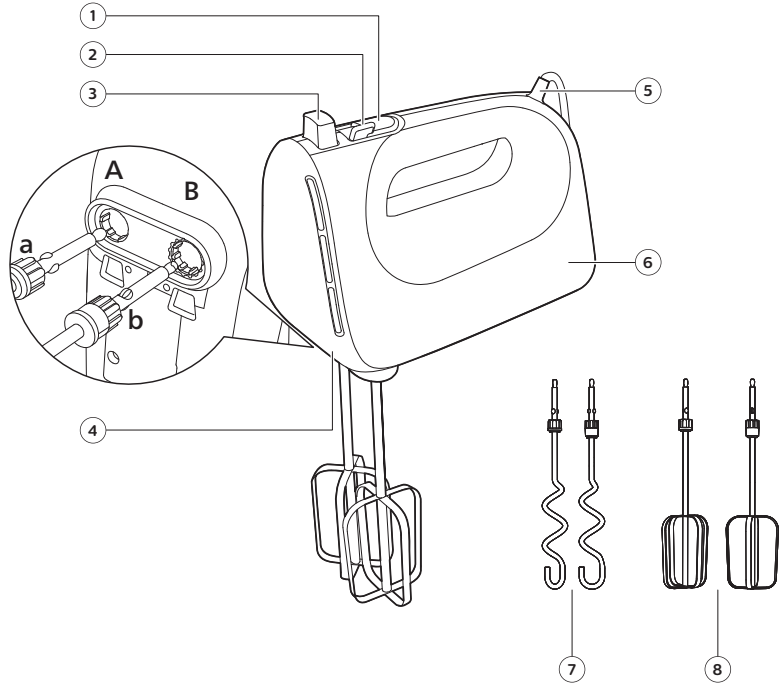

- 1 Turbo düğmesi  
Maksimum hıza ulaşmak için basılı tutun
- 2 Hız kontrolü  
0: KAPALI konumda  
1-5: hız ayarı
- 3 Çıkarma düğmesi  
Çırpıcıları veya hamur kancalarını çıkarmak için basın
- 4 Çırpıcının ve hamur kancalarının deliği
- 5 Güç kablosu
- 6 Ana ünite
- 7 İki hamur kancası
- 8 İki çırpıcı

## İlk kullanımdan önce

İlk kullanımdan önce cihazı ve aksesuarları sabunlu ılık suyla yıkayın. Bunları iyice durulayın ve monte etmeden önce tamamen kurulayın.

Isı kaynaklarının, suyun veya yanıcı malzemelerin yakınına koymayın.

## Cihazı kullanma

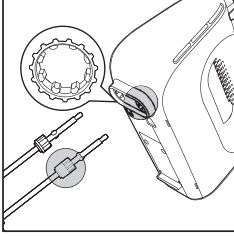

1 Çırpıcıları veya yoğurma kancalarını ana üniteye takın.

**Plastik halkaya sahip çırpıcıyı veya yoğurma kancasını daha büyük açıklığa yerleştirin.**

2 Fişi prize takın.

3 Malzemeleri bir kaseye koyun.

**"İşlem miktarları ve işlem süreleri" bölümündeki önerilen miktarlara ve işlem sürelerine bakın.**

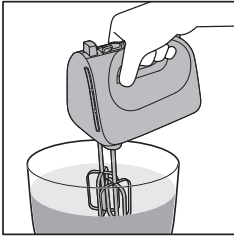

4 Çırpıcıları veya yoğurma kancalarını malzemenin içine doğru indirin.

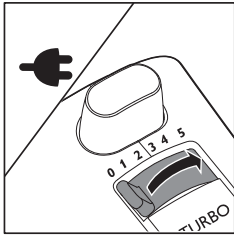

5 Cihazı açmak için hız kontrolünü istediğiniz hız ayarına getirin.

**Sıçramayı önlemek için düşük hızda karıştırmaya başlayın. Ardından daha yüksek bir hıza geçin.**

Turbo düğmesine basarak daha hızlı karıştırabilir veya mayalı hamur yoğurma gibi ağır işlerde hızı artırabilirsiniz.

Karıştırma işlemini bir süreliğine durdurmak istiyorsanız cihazı kapatmak için hız kontrolünü "0" olarak ayarlayın.

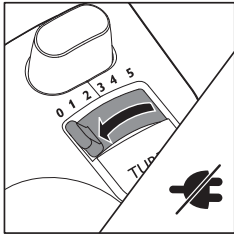



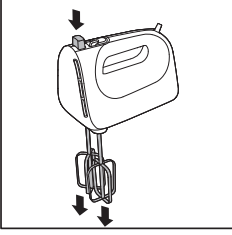





6 Karıştırma işlemini tamamladığınızda hız kontrolünü "0" olarak ayarlayın ve cihazın fişini çekin.

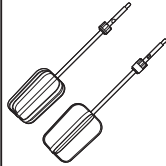

7 Çırpıcıları veya yoğurma kancalarını çıkarmak için çıkarma düğmesine basın.

## İşlem miktarları ve işlem süresi

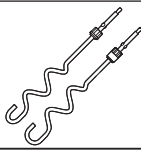
Belirtilen maksimum miktarları ve işlem sürelerini aşmayın.

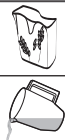



		 Kg (MAX)		
		500 ml	6 min	5
		8 x	2 min	5
		750 g	3 min	1-5
		1000 g	5 min	5
		720 g		

## Temizlik ve Bakım

**Temizlemeye başlamadan önce, cihazın fişini mutlaka prizden çekin.**

**Motor ünitesini kesinlikle suya batırmayın veya musluk altında durulamayın.**

- 1 Çırpıcıları ve yoğurma kancalarını bir miktar bulaşık deterjanıyla ılık suda veya bulaşık makinesinde yıkayın.
- 2 Motor ünitesini nemli bezle silerek temizleyin.

			
	✗	✗	✓
	✓	✓	✓

# Εισαγωγή

Συγχαρητήρια για την αγορά σας και καλώς ήρθατε στη Philips!  
 Για να επωφεληθείτε πλήρως από την υποστήριξη που προσφέρει η Philips, δηλώστε το προϊόν σας στη διεύθυνση [www.philips.com/welcome](http://www.philips.com/welcome).

## Γενική περιγραφή

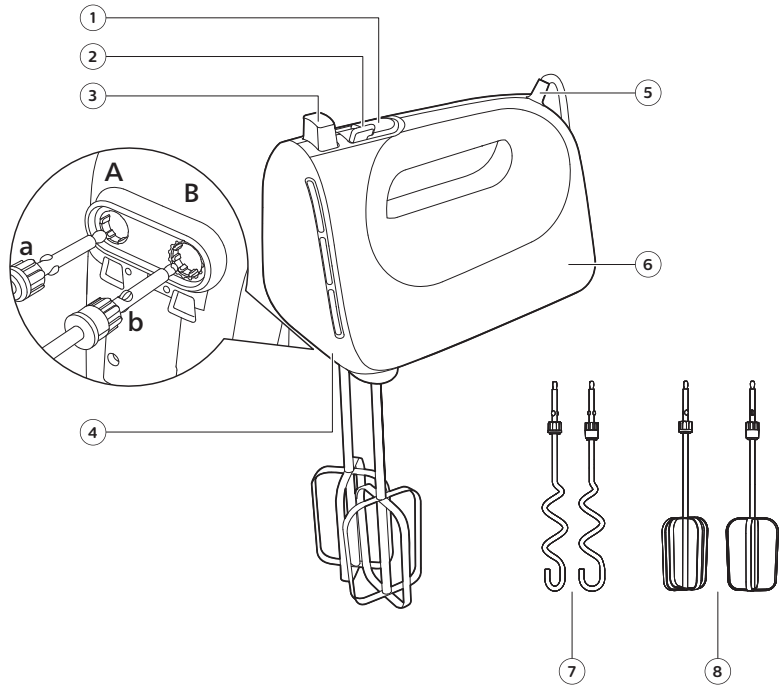

- 1 Κουμπί Turbo  
 Πατήστε παρατεταμένα για μέγιστη ταχύτητα
- 2 Έλεγχος ταχύτητας  
 0: Θέση OFF  
 1-5: ρύθμιση ταχύτητας
- 3 Κουμπί εξαγωγής  
 Πατήστε για να αποσυνδέσετε τα εξαρτήματα ανάμειξης ή ζύμωσης
- 4 Υποδοχή για τα εξαρτήματα ανάμειξης και ζύμωσης
- 5 Καλώδιο ρεύματος
- 6 Κύρια μονάδα
- 7 Δύο εξαρτήματα ζύμωσης
- 8 Δύο εξαρτήματα ανάμειξης

## Πριν την πρώτη χρήση

Πριν από την πρώτη χρήση, πλύνετε τη συσκευή και τα εξαρτήματα με ζεστό σαπουνόνερο. Ξεπλύνετε τα καλά και στεγνώστε τα εντελώς πριν τα συναρμολογήσετε.

Αποφύγετε να το τοποθετείτε κοντά σε πηγές θερμότητας, νερό ή εύφλεκτα υλικά.

## Χρήση της συσκευής

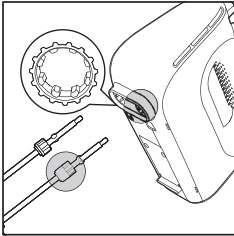

- 1 Τοποθετήστε τα εξαρτήματα ανάμειξης ή ζύμωσης στην κύρια μονάδα.

**Τοποθετήστε το εξάρτημα ανάμειξης ή ζύμωσης με τον πλαστικό δακτύλιο στη μεγαλύτερη υποδοχή.**

- 2 Συνδέστε το φισ στην πρίζα.
- 3 Βάλτε τα υλικά σε ένα κάδο.

**Δείτε τις συνιστώμενες ποσότητες και τους χρόνους επεξεργασίας στην ενότητα "Ποσότητες και χρόνοι επεξεργασίας".**

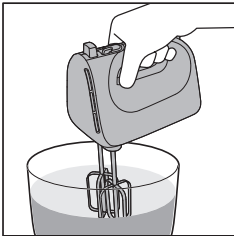

- 4 Βυθίστε τα εξαρτήματα ανάμειξης ή ζύμωσης στα υλικά.

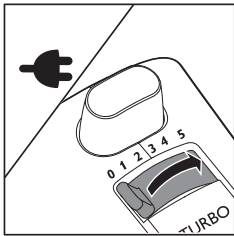

- 5 Για να θέσετε σε λειτουργία τη συσκευή, ρυθμίστε τον έλεγχο ταχύτητας στην επιθυμητή ταχύτητα.

**Για να αποφύγετε το πιτσίλισμα, ξεκινήστε να ανακατεύετε σε χαμηλή ταχύτητα. Επιλέξτε αργότερα υψηλότερη ταχύτητα.**

Μπορείτε να πατήσετε το κουμπί Turbo για πιο γρήγορο ανακάτεμα ή για να αυξήσετε την ταχύτητα στις πιο δύσκολες εργασίες, π.χ. ζύμωμα ζύμης με μαγιά.

Αν θέλετε να σταματήσετε για λίγο το ανακάτεμα, θέστε τον έλεγχο ταχύτητας στη θέση "0" για να απενεργοποιήσετε τη συσκευή.

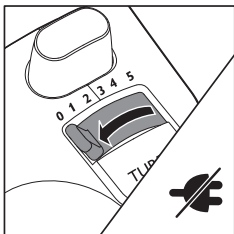

- 6 Όταν τελειώσετε το ανακάτεμα, θέστε τον έλεγχο ταχύτητας στη θέση "0" και αποσυνδέστε τη συσκευή από την πρίζα.



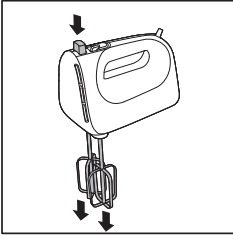









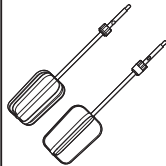

7 Για να αποσυνδέσετε τα εξαρτήματα ανάμειξης ή ζύμωσης, πατήστε το κουμπί εξαγωγής.

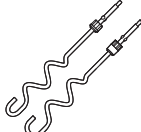
## Ποσότητες και χρόνος επεξεργασίας

Μην υπερβαίνετε τις μέγιστες ποσότητες και τους χρόνους επεξεργασίας που αναφέρονται.





		 Kg (MAX)		
		500 ml	6 min	5
		 x8	2 min	5
		750 g	3 min	1-5
		 1000 g	5 min	5
		720 g		

## Καθαρισμός και συντήρηση

**Αποσυνδέετε πάντα τη συσκευή από την πρίζα προτού την καθαρίσετε.**

**Μην βυθίζετε ποτέ τη μονάδα μοτέρ σε νερό και μην την ξεπλένετε με νερό βρύσης.**

- 1 Καθαρίστε τα εξαρτήματα ανάμειξης και ζύμωσης σε ζεστό νερό με λίγο υγρό πιάτων ή βάλτε τα στο πλυντήριο πιάτων.
- 2 Καθαρίστε τη μονάδα μοτέρ με ένα υγρό πανί.

			
	✗	✗	✓
	✓	✓	✓

## Въведение

Поздравления за покупката и добре дошли във Philips!

За да се възползвате изцяло от предлаганата от Philips поддръжка, регистрирайте продукта си на [www.philips.com/welcome](http://www.philips.com/welcome).

## Общо описание

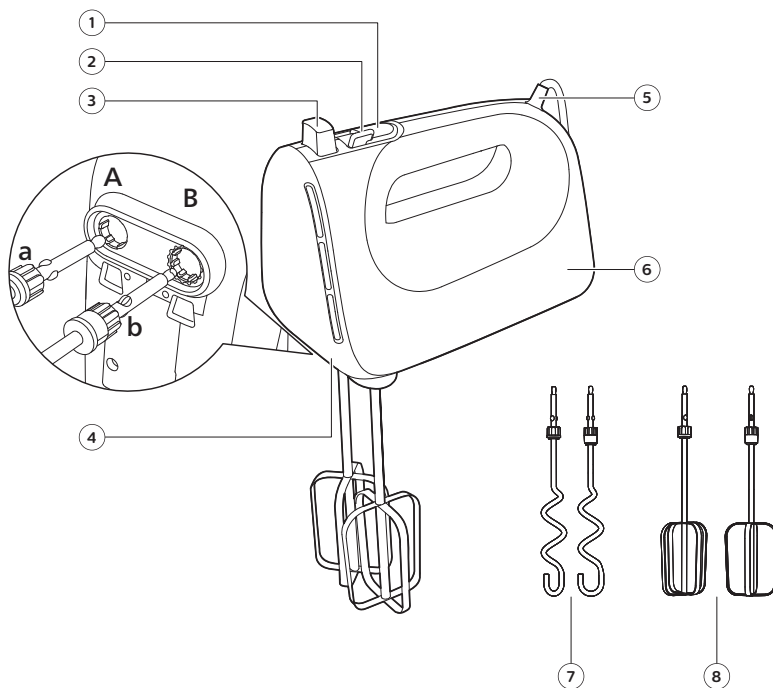

- 1 Бутон "турбо"  
Натиснете и задръжте за достигане на максимална скорост
- 2 Регулиране на скоростта  
0: Положение ИЗКЛ.  
1 – 5: настройка на скоростта
- 3 Бутон за изваждане  
Натиснете, за да освободите бъркалките или куките за месене
- 4 Отвор за бъркалките и куките за месене
- 5 Захранващ кабел
- 6 Основен блок
- 7 Две куки за тесто
- 8 Две бъркалки

## Преди първата употреба

Преди първата употреба измийте уреда и аксесоарите с топла сапунена вода. Изплакнете ги щателно и ги подсушете напълно преди да ги сглобите. Избягвайте да го поставяте близо до топлинни източници, вода или запалими материали.

## Използване на уреда

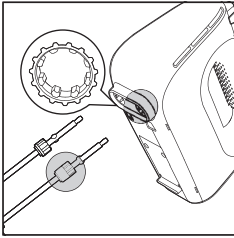

- 1 Поставете бъркалките или куките за месене в главното устройство.

**Поставете бъркалката или куката за месене с пластмасовия пръстен в по-големия отвор.**

- 2 Включете щепсела в контакта.
- 3 Поставете продуктите в купа.

**Вижте препоръчителните количества и времена за обработка в раздела "Количества за обработка и времена за обработка".**

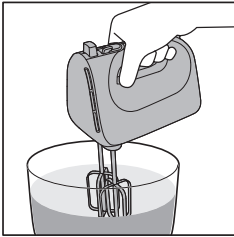

- 4 Спуснете бъркалките или куките за месене в съставките.

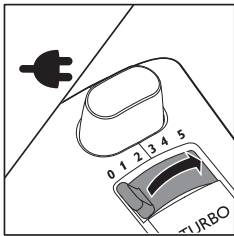

- 5 Поставете регулатора на скоростта в желаното положение, за да включите уреда.

**Започнете да разбърквате на ниска скорост, за да избегнете пръски. Превключете на по-висока скорост по-късно.**

Можете да натиснете бутона "турбо", за да разбърквате по-бързо или за да вдигнете скоростта при трудни за обработване продукти, напр. при месене на тесто с мая.

Ако искате да спрете разбъркването за известно време, преместете регулатора на скоростта на "0", за да изключите уреда.

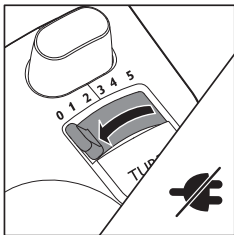



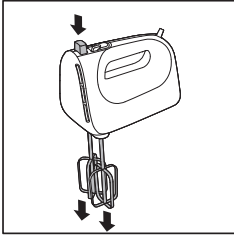





- 6 Когато свършите с разбъркването, преместете регулатора на скоростта в положение "0" и изключете уреда от контакта.

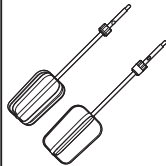

7 За да освободите бъркалките или куките за месене, натиснете бутона за изваждане.

## Количества за обработка и време за обработка

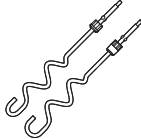
Не превишавайте максималните количества и време за обработка, които са посочени.





		 Kg (MAX)		
		500 ml	6 min	5
		 x8	2 min	5
		750 g	3 min	1-5
		1000 g	5 min	5
		720 g		

## Почистване и поддръжка

**Винаги изключвайте уреда от контакта, преди да пристъпите към почистване.**

**Не потапяйте блока на мотора във вода и не го изплаквайте с течаща вода.**

- 1 Измийте бъркалките и куките за месене в топла вода с малко течен миещ препарат или в съдомиялна машина.
- 2 Почистете задвижващия блок с влажна кърпа.

			
	✗	✗	✓
	✓	✓	✓

## Вовед

Ви честитаме за купувањето и добре дојдовте во Philips!

За да целосно ја искористите поддршката што ја нуди Philips, регистрирајте го вашиот производ на [www.philips.com/welcome](http://www.philips.com/welcome).

## Општ опис

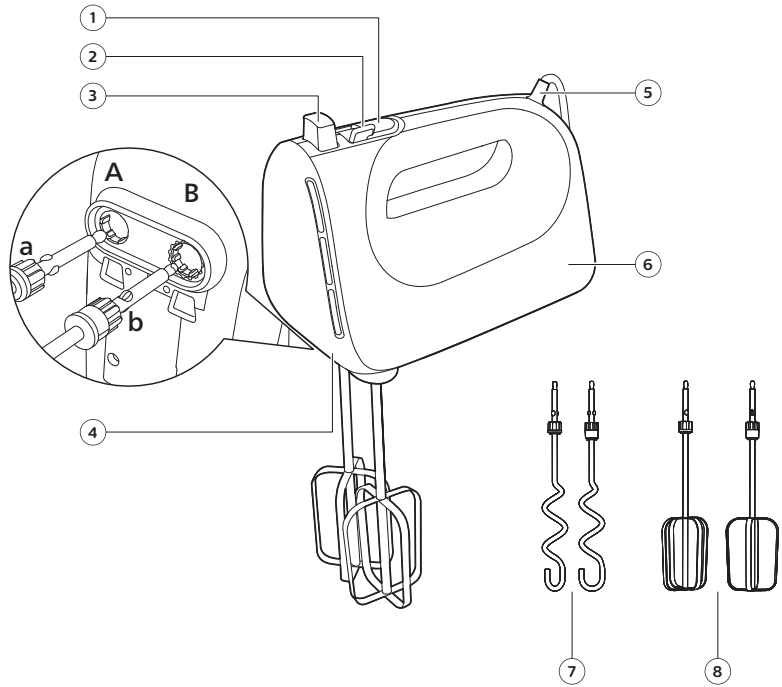

- 1 Копче Turbo  
Притиснете и задржете за да ја постигнете максималната брзина
- 2 Контрола на брзина  
0: положба OFF (ИСКЛУЧЕНО)  
1-5: поставка за брзина
- 3 Копче за исфрлување  
Притиснете за да ги ослободите додатоките за матење или спиралните додатоци за тесто
- 4 Отвор за додатоките за матење и спиралните додатоци за тесто
- 5 Кабел за напојување
- 6 Главна единица
- 7 Два спирални додатоци за тесто
- 8 Два додатоци за матење

## Пред првото користење

Пред првата употреба, измијте ги додатците и апаратот со топла вода и сапун. Исплакнете ги темелно и оставете целосно да се исушат пред да ги склопите.

Избегнувајте да го поставувате во близина на извори на топлина, вода или запаливи материјали.

## Користење на апаратот

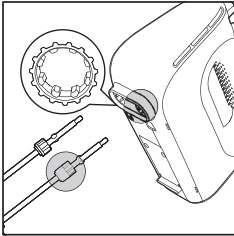

- 1 Вметнете ги додатците за матење или спиралните додатци за тесто во главната единица.

**Вметнете го додатокот за матење или спиралниот додаток за тесто со пластичниот прстен во поголемиот отвор.**

- 2 Вметнете го приклучокот во ѕидниот штекер.
- 3 Ставете ги состојките во сад.

**Погледнете ги препорачаните количини и времиња на обработка во делот „Количини за обработка и времиња на обработка“.**

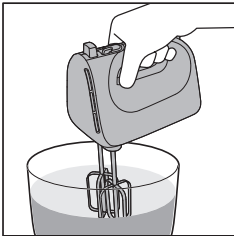

- 4 Спуштете ги додатците за матење или спиралните додатци за тесто во состојките.

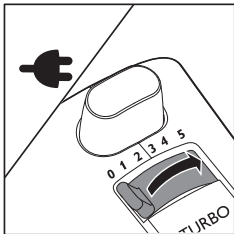

- 5 Поставете ја контролата за брзина на саканата поставка за брзина за да го вклучите апаратот.

**Започнете да мешате со мала брзина за да избегнете прскање. Потоа изберете поголема брзина.**

Можете да го притиснете копчето Turbo за побрзо мешање или да ја зголемите брзината за тешки задачи, на пр. месење тесто со квасец.

Ако сакате да го прекинете мешањето накратко, поставете ја контролата за брзина на „0“ за да го исклучите апаратот.

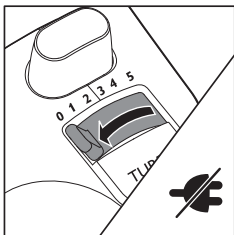

- 6 Кога ќе завршите со мешањето, поставете ја контролата за брзина на „0“ и исклучете го апаратот од штекер.



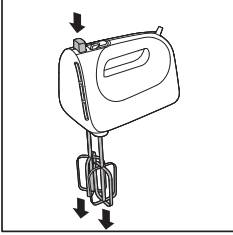









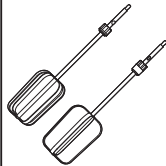

- 7 За да ги отпуштите додатоците за матење или спиралните додатоци за тесто, притиснете го копчето за исфрлање.

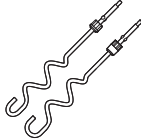
## Количини за обработка и време на обработка

Не надминувајте ги наведените максимални количини и времиња на обработка.





		 Kg (MAX)		
		500 ml	6 min	5
		 x8	2 min	5
		750 g	3 min	1-5
		 1000 g	5 min	5
		720 g		

## Чистење и одржување

**Секогаш исклучувајте го апаратот од штекер пред да го чистите.**

**Никогаш немојте да ја потопувате моторната единица во вода и немојте да ја плакнете под чешма.**

- 1 Чистете ги додатоците за матење и спиралните додатоци за тесто во топла вода со малку течност за миење садови или во машина за садови.
- 2 Исчистете ја моторната единица со влажна крпа.

			
	✗	✗	✓
	✓	✓	✓

## Введение

Поздравляем с покупкой и приветствуем в клубе Philips!

Чтобы воспользоваться всеми преимуществами поддержки Philips, зарегистрируйте прибор на веб-сайте [www.philips.com/welcome](http://www.philips.com/welcome).

## Общее описание

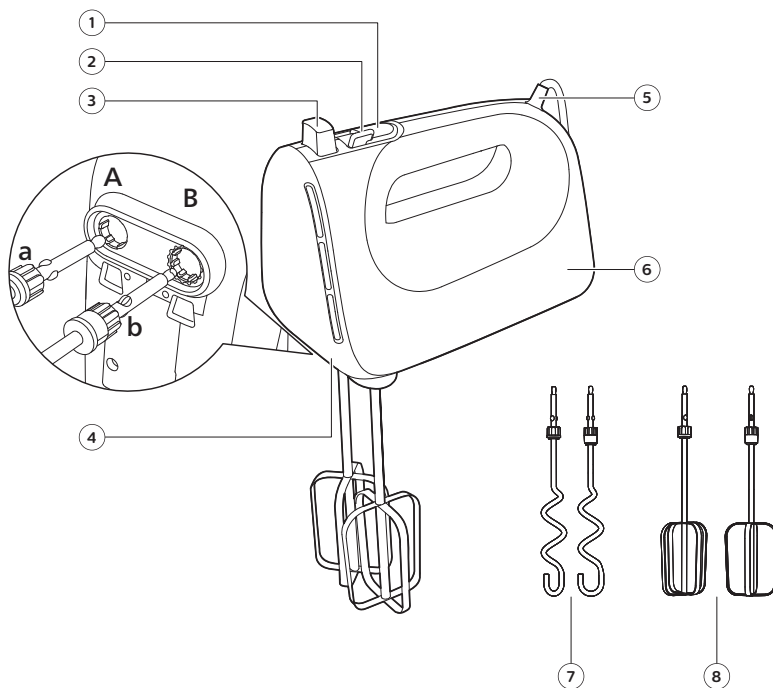

- 1 Кнопка Turbo  
Нажмите и удерживайте для максимальной скорости
- 2 Регулятор скорости  
0: Положение "Выкл."  
1–5: значение скорости
- 3 Кнопка отсоединения  
Нажмите, чтобы отсоединить венчики или крюки для теста
- 4 Отверстие для венчиков и крюков для теста
- 5 Шнур питания
- 6 Основное устройство
- 7 Два крюка для теста
- 8 Два венчика

## Перед первым использованием

Перед первым использованием вымойте прибор и аксессуары в теплой мыльной воде. Тщательно сполосните их и дайте им полностью высохнуть перед сборкой.

Не располагайте его возле источников тепла и воды, а также легковоспламеняющихся материалов.

## Использование прибора

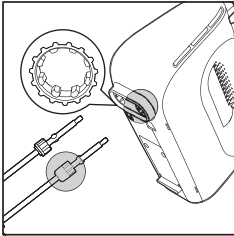

- 1 Вставьте венчики или крюки для теста в основное устройство.

**Вставьте венчик или крюк для теста с пластиковой защитой в большое отверстие.**

- 2 Вставьте вилку сетевого шнура в розетку электросети.
- 3 Положите ингредиенты в чашу.

**См. рекомендованное количество и время смешивания в разделе "Количество и время смешивания".**

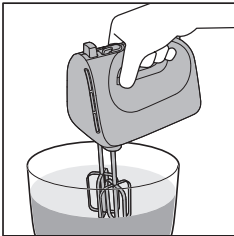

- 4 Погрузите вставленные венчики или крюки для теста в рабочую емкость.

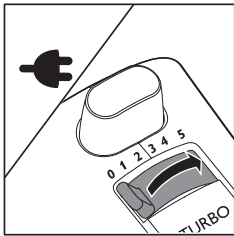

- 5 Выберите на регуляторе скорости необходимое значение, чтобы включить прибор.

**Начинайте смешивать на малой скорости, чтобы избежать разбрызгивания. Затем переключите на более высокую скорость.**

Нажмите кнопку Turbo для более быстрого перемешивания продуктов или увеличения скорости при работе с вязкими смесями, например с дрожжевым тестом.

Для приостановки смешивания выберите на регуляторе скорости значение 0 — это приведет к отключению прибора.

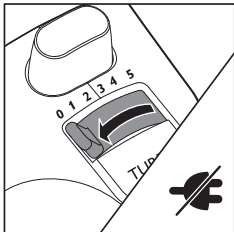



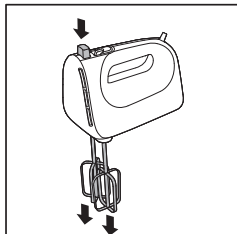







- 6 По окончании смешивания выберите на регуляторе скорости значение 0 и извлеките штекер из розетки электросети.

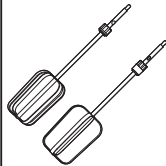

- 7 Для извлечения венчиков или крюков для теста нажмите кнопку извлечения.

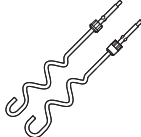
## Количество продуктов и время обработки

Не заполняйте емкость выше максимальной отметки; время обработки не должно превышать указанное.





		 Kg (MAX)		
		500 ml	6 min	5
		 x8	2 min	5
		750 g	3 min	1-5
		 1000 g	5 min	5
		 720 g		

## Очистка и уход

**Перед очисткой прибора обязательно отсоединяйте его от электросети.**

**Запрещается погружать моторный блок в воду и промывать его под струей воды.**

- 1 Для очистки венчиков или крючков для теста поместите их в теплую воду с добавлением небольшого количества жидкого моющего средства или в посудомоечную машину.
- 2 Очищайте моторный блок с помощью влажной ткани.

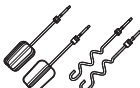
			
	✗	✗	✓
	✓	✓	✓

## Вступ

Вітаємо з придбанням виробу Philips!

Щоб уповні скористатися підтримкою, яку пропонує Philips, зареєструйте свій виріб на веб-сайті [www.philips.com/welcome](http://www.philips.com/welcome).

## Загальний опис

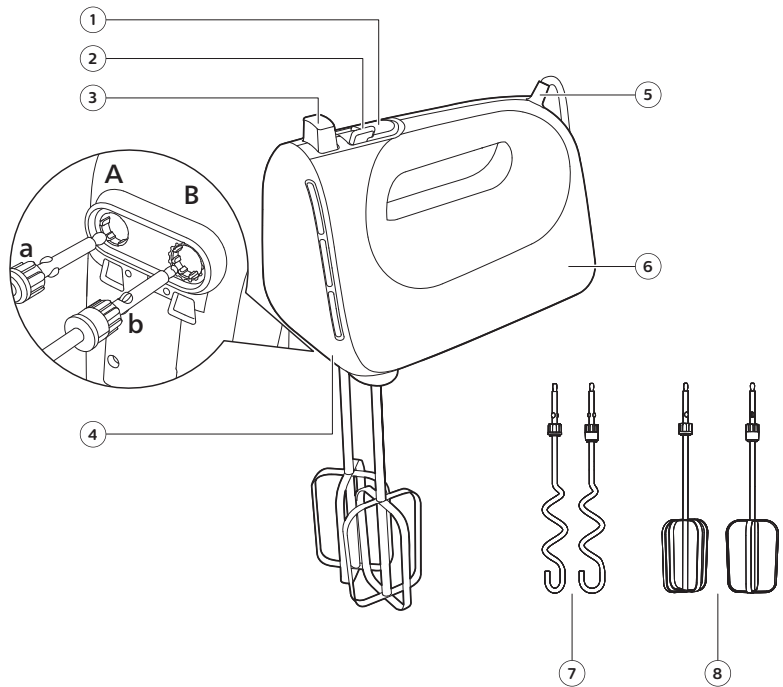

- 1 Кнопка "турбо"  
Натисніть та утримуйте для досягнення максимальної швидкості
- 2 Регулятор швидкості  
0: Положення OFF  
1–5: налаштування швидкості
- 3 Кнопка виймання  
Натисніть, щоб вийняти вінчики або гаки для замішування тіста
- 4 Отвір для вінчиків і гаків для замішування тіста
- 5 Кабель живлення
- 6 Головний блок
- 7 Два гаки для замішування тіста
- 8 Два вінчики

## Перед першим використанням

Перед першим використанням помийте пристрій та аксесуари теплою водою з миючим засобом. Ретельно сполосніть їх і повністю висушіть перед збиранням.

Не ставте його поблизу джерел тепла, води або займистих матеріалів.

## Використання пристрою

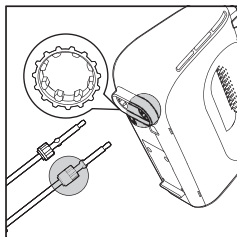

- 1 Опустіть вінчики або замішувачі для тіста в головний блок.

**Встановіть вінчик або замішувач для тіста з пластиковим кільцем у більший отвір.**

- 2 Вставте штепсель у розетку на стіні.

- 3 Покладіть продукти у чашу.

**Рекомендовану кількість продуктів і тривалість обробки див. у розділі «Кількість продуктів і тривалість переробки».**

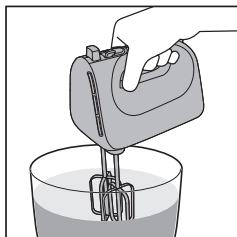

- 4 Опустіть вінчики або замішувачі для тіста в продукти.

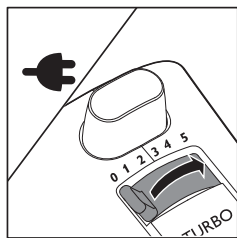

- 5 Щоб увімкнути пристрій, налаштуйте регулятор швидкості на бажаний режим швидкості.

**Почніть змішувати на низькій швидкості, щоб уникнути бризок. Пізніше перемкніть на вищу швидкість.**

Можна натиснути кнопку "турбо", щоб змішувати швидше або щоб збільшити швидкість обробки густих продуктів, наприклад, під час змішування дріжджового тіста.

Якщо потрібно на якийсь час зупинити обробку, встановіть регулятор швидкості в положення "0", щоб вимкнути пристрій.

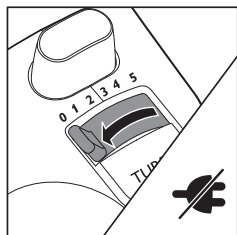

- 6 Завершивши змішування, встановіть регулятор швидкості на "0" і від'єднайте пристрій від мережі.



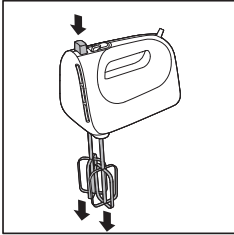







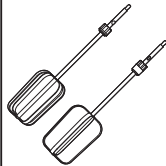

7 Щоб зняти вінчики або замішувачі для тіста, натисніть кнопку виймання.

## Кількість продуктів і тривалість переробки

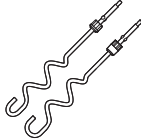
Не перевищуйте максимальну кількість продуктів і вказану тривалість переробки.

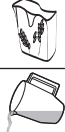



		 Kg (MAX)		
		500 ml	6 min	5
		 x8	2 min	5
		750 g	3 min	1-5
		1000 g	5 min	5
		720 g		

## Чищення та догляд

**Перед чищенням завжди витягуйте штекер пристрою із розетки.**

**Ні в якому разі не занурюйте блок двигуна у воду і не мийте його під краном.**

- 1 Мийте вінчики та замішувачі для тіста у теплій воді з миючим засобом або у посудомийній машині.
- 2 Блок двигуна почистьте вологою ганчіркою.

			
	✗	✗	✓
	✓	✓	✓

## Кіріспе

Осы затты сатып алуыңызбен құттықтаймыз және Philips компаниясына қош келдіңіз!

Philips ұсынатын қолдауды толық пайдалану үшін өнімді [www.philips.com/welcome](http://www.philips.com/welcome) веб-сайтында тіркеңіз.

## Жалпы сипаттамасы

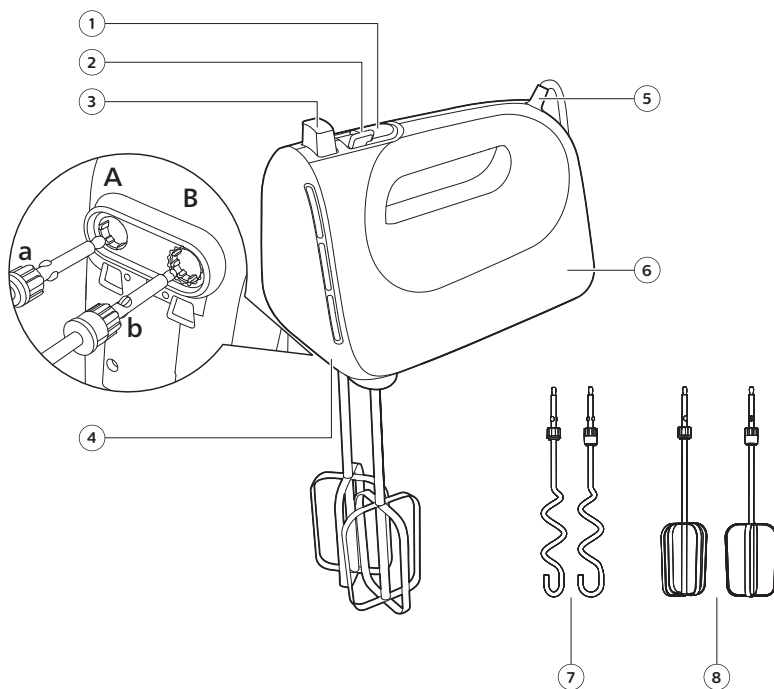

- 1 Турбо түймесі  
Ең жоғары жылдамдыққа жету үшін түймені басып тұрыңыз
- 2 Жылдамдықты басқару  
0: OFF (Өшірулі) күйі  
1-5: жылдамдық параметрі
- 3 Босату түймесі  
Бұлғауыштарды немесе қамыр илегіштерді босату үшін басыңыз
- 4 Бұлғауыштар мен қамыр илегіштерге арналған тесік
- 5 Ток сымы
- 6 Негізгі бөлік
- 7 Екі қамыр илегіш
- 8 Екі шайқағыш

## Алғашқы рет қолданар алдында

Алғаш қолданар алдында құралды және керек-жарақтарды жылы сабынды сумен жуыңыз. Жинамас бұрын оларды жақсылап шайып, толық құрғатыңыз.

Оны жылу көздерінің, судың немесе жанғыш материалдардың жанына қоймаңыз.

## Құралды қолдану

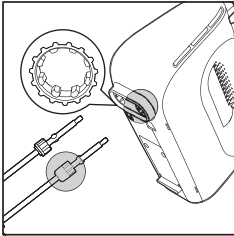

1 Шайқағыштарды немесе илейтін ілмектерді негізгі бөлікке салыңыз.

**Кеңірек тесікке шайқағыш немесе пластмассадан жасалған ұшы бар илейтін ілмекті орнатыңыз.**

2 Штепсельдік ұшты қабырға розеткасына қосыңыз.

3 Ингредиенттерді ыдысқа салыңыз.

**Ұсынылатын көлемдер мен өңдеу уақыттарын «Өңдеу мөлшері және өңдеу уақыты» бөлімінен қараңыз.**

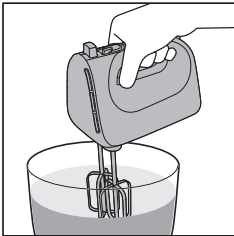

4 Шайқағыштарды немесе илейтін ілмектерді ыдыстағы қоспаға салыңыз.

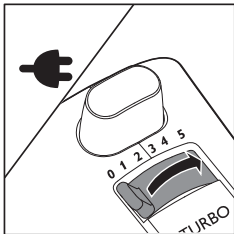

5 Құралды қосу үшін, жылдамдық түймесін қажетті жылдамдық мәніне қойыңыз.

**Шашырамау үшін төмен жылдамдықпен араластыруды бастаңыз. Кейін жоғары жылдамдыққа ауысыңыз.**

Жылдамырақ шайқау үшін турбо түймесін басуға немесе ашыған қамырды илеу сияқты ауыр тапсырмалар барысында, жылдамдықты арттыруға болады.

Араластыруды біраз уақытқа тоқтатқыңыз келсе, құралды өшіру үшін жылдамдық түймесін «0» мәніне қойыңыз.

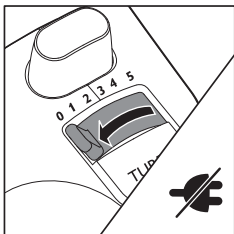



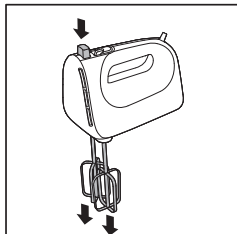





6 Араластырып болғанда, жылдамдық түймесін «0» мәніне қойып, құралды розеткадан ажыратыңыз.

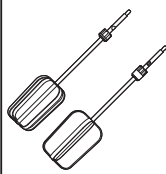

- 7 Шайқағыштарды немесе илейтін ілмектерді босату үшін «Шығару» түймесін басыңыз.

## Өңдеу көлемдері мен өңдеу уақыты

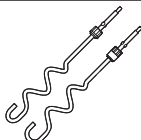
Максимум мөлшерлер мен өңдеу уақыттарынан асырмаңыз.





		 Kg (MAX)		
		500 ml	6 min	5
		8 x	2 min	5
		750 g	3 min	1-5
		1000 g	5 min	5
		720 g		

## Тазалау және техникалық қызмет көрсету

Тазалау алдында құралды міндетті түрде розеткадан ажырату керек.

Моторды суға немесе басқа сұйықтыққа батыруға және ағын сумен шаюға болмайды.

- 1 Шайқағыштар мен илейтін ілмектерді ыдыс жуатын сұйықтық қосып, жылы сумен немесе ыдыс жуғышта жууға болады.
- 2 Моторды дымқыл шүберекпен сүртіңіз.

			
	✗	✗	✓
	✓	✓	✓

# מבוא

ברכותינו על רכישתך וברוך בואך למשפחת מוצרי פיליפס!  
 כדי להפיק את מלוא התועלת מהתמיכה שפיליפס מעניקה ללקוחותיה, רשמו את המוצר  
 בכתובת [www.philips.com/welcome](http://www.philips.com/welcome).

## תיאור כללי

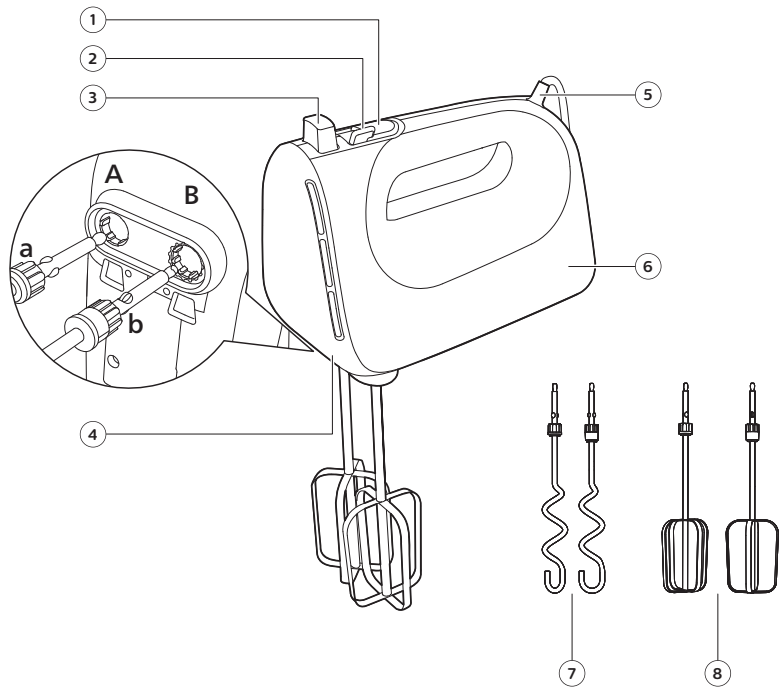

- 1 לחצן טורבו  
יש ללחוץ ברציפות כדי להגיע למהירות המרבית
- 2 בקרת מהירות  
0: מצב כיבוי (OFF)  
1-5: הגדרת מהירות
- 3 לחצן שליפה  
יש ללחוץ כדי לשחרר את המקצפים או ווי הלישה
- 4 חור למקצפים ולווי הלישה  
כבל מתח
- 5 יחידת המנוע
- 6 שני ווי הלישה
- 7 שני מקצפים
- 8 שני מקצפים

## לפני השימוש הראשון

לפני השימוש הראשון, יש לשטוף את המכשיר והאביזרים במים חמים עם סבון. יש לשטוף ביסודיות ולייבש אותם לחלוטין לפני ההרכבה.  
אין לשים אותו ליד מקורות חום, מים, או חומרים דליקים.

## שימוש במכשיר

1 יש להכניס את המקציפים או את ווי הלישה לתוך היחידה הראשית.

**יש להכניס את המקצף או את ווי הלישה עם קולר הפלסטיק לתוך הפתח הגדול.**

2 יש להכניס את התקע לשקע שבקיר.

3 יש לשים את רכיבי המזון בקערה.

**הכמויות זמני העיבוד המומלצים נמצאים במקטע "כמויות עיבוד זמני עיבוד".**

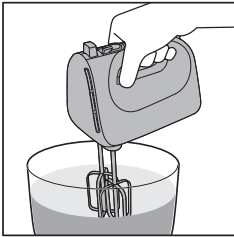
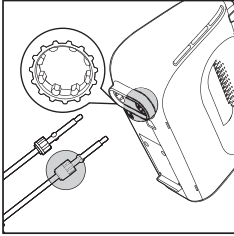

4 יש להנמיך את המקציפים או את ווי הלישה לתוך הרכיבים.

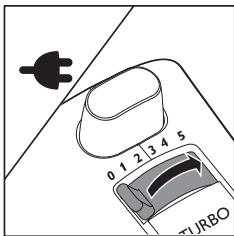

5 יש להגדיר את בקרת המהירות להגדרת המהירות הרצויה כדי להפעיל את המכשיר.

**יש להתחיל לערבול במהירות נמוכה כדי להימנע מהשפרצות. יש לעבור למהירות גבוהה יותר לאחר מכן.**

אפשר ללחוץ על לחצן הטורבו כדי לערבול מהר יותר או כדי להעלות את המהירות בזמן משימות כבדות, למשל לישת בצק שמרים.

אם ברצונך להפסיק לערבול לזמן מה, יש להגדיר את בקרת המהירות ל-'0' כדי לכבות את המכשיר.

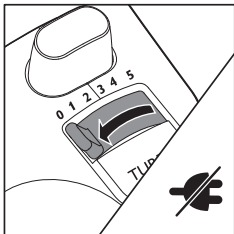

6 כאשר סיימת את הערבול, יש להגדיר את בקרת המהירות ל-'0' ולנתק את המכשיר מהחשמל.



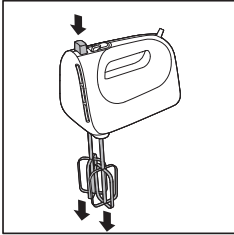







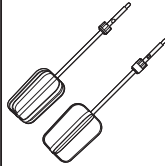

7 כדי לשחרר את המקצפים או את ווי הלישה, יש ללחוץ על לחצן השליפה.

## כמויות עיבוד וזמן העיבוד

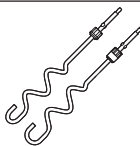
אין לחרוג מהכמויות המרביות ומזמני העיבוד המרביים המצוינים.





		 Kg (MAX)		
		500 ml	6 min	5
		 x8	2 min	5
		750 g	3 min	1-5
		1000 g	5 min	5
		720 g		

## ניקוי ותחזוקה

לפני הניקוי, יש להקפיד לנתק את המכשיר משקע החשמל.

לעולם אין לטבול את יחידת המנוע במים ואין לשטוף אותה תחת מים זורמים.

- 1 יש לנקות את המקצפים ואת ווי הלישה במים חמים עם נוזל ניקוי או במדיח הכלים.
- 2 יש לנקות את יחידת המנוע עם מטלית לכה.

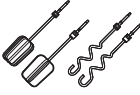
			
	✗	✗	✓
	✓	✓	✓









2025 © Versuni Holding B.V.

PHILIPS and the Philips Shield Emblem are registered trademarks of Koninklijke Philips N.V. and are used under license.

This product has been manufactured by and is sold under the responsibility of Versuni Holding B.V., and Versuni Holding B.V. is the warrantor in relation to this product.

(11/2025)



100%   
www.home.id

Ovaj dokument je originalno proizveden i objavljen od strane proizvođača, brenda Philips, i preuzet je sa njihove zvanične stranice. S obzirom na ovu činjenicu, Tehnoteka ističe da ne preuzima odgovornost za tačnost, celovitost ili pouzdanost informacija, podataka, mišljenja, saveta ili izjava sadržanih u ovom dokumentu.

Napominjemo da Tehnoteka nema ovlašćenje da izvrši bilo kakve izmene ili dopune na ovom dokumentu, stoga nismo odgovorni za eventualne greške, propuste ili netačnosti koje se mogu naći unutar njega. Tehnoteka ne odgovara za štetu nanесenu korisnicima pri upotrebi netačnih podataka. Ukoliko imate dodatna pitanja o proizvodu, ljubazno vas molimo da kontaktirate direktno proizvođača kako biste dobili sve detaljne informacije.

Za najnovije informacije o ceni, dostupnim akcijama i tehničkim karakteristikama proizvoda koji se pominje u ovom dokumentu, molimo posetite našu stranicu klikom na sledeći link:

<https://tehnoteka.rs/p/philips-rucni-mikser-hr373900-akcija-cena/>