

Uputstvo za upotrebu (EN)

FIELDMANN FVC 8010-EC pumpa za vodu



Tehnoteka je online destinacija za upoređivanje cena i karakteristika bele tehnike, potrošačke elektronike i IT uređaja kod trgovinskih lanaca i internet prodavnica u Srbiji. Naša stranica vam omogućava da istražite najnovije informacije, detaljne karakteristike i konkurentne cene proizvoda.

Posetite nas i uživajte u ekskluzivnom iskustvu pametne kupovine klikom na link:

<https://tehnoteka.rs/p/fieldmann-fvc-8010-ec-pumpa-za-vodu-akcija-cena/>



FVC 8010 EC

English	3-10
Čeština.....	13-21
Slovenščina.....	23-31
Magyarul	33-40
Polski	41-48
Slovenščina	49-56

Garden pump

USER MANUAL

Thank you for purchasing this pump. Before using it, please carefully read this User manual and keep it in a safe place for further use.

CONTENTS

1. GENERAL SAFETY REGULATIONS	4
Important safety information.....	4
Packaging	4
User Manual.....	4
Electrical safety	4
2. DESCRIPTION OF THE MACHINE AND CONTENTS.....	5
Description of the machine (see Fig. 1)	5
3. INSTALLATION AND RUNNING	5
Installation (Fig. 2.).....	6
4. ELECTRICAL CONNECTION	7
5. RUNNING	7
6. MAINTENANCE AND CLEANING	7
7. WHAT TO DO "WHEN..."	8
8. TECHNICAL SPECIFICATIONS.....	9
9. DISPOSAL.....	10

1. GENERAL SAFETY REGULATIONS

Important safety notice

- ✿ Carefully unpack the product and take care not to throw away any part of the packaging until all the product parts have been identified.
- ✿ Read all warnings and instructions. Not following warnings or instructions may lead to injury from an electric shock, fire and/or serious injuries.

⚠ ATTENTION! Protect yourself against electric shocks!

Packaging

The device is contained in a package intended to prevent any damage during transport. This package is a resource and so it can be handed over for recycling.

User manual

Before first using the pump, please read the following safety instructions and the User manual. Learn about all the parts and the correct use of the device. Keep the User manual in a safe place where it can be easily retrieved for future use. If giving the device to somebody else, do so together with the User manual. Following the instructions in the included User manual is a prerequisite for safe use of the garden appliance. The User manual also contains operating, maintenance, and repair instructions.

📖 NOTE: If giving the machine to somebody else, do so together with this User manual.

Following the instructions in the included User manual is a prerequisite for the proper use of the appliance. The User manual also contains operating, maintenance, and repair instructions.

Electrical safety

The pump can be connected to any power plug installed according to the given norms. The plug must be powered at 230 V ~ 50 Hz.

⚠ ATTENTION! Important for the protection of your personal safety. Before first starting your new submersible pump, make sure that the following items are professionally checked:

- Grounding
- Neutral conductor

The current circuit breaker must conform to energy safety norms and must fully function correctly.

The electrical connection must be protected against moisture.

If there is a risk of the electrical connection being flooded, it must be moved higher.

- In all situations, prevent the circulation of aggressive liquids and coarse materials.

The submersible pump must be protected against frost.

The pump must be protected against running when empty.

Prevent children from accessing parts of the pump by taking the appropriate measures.

The manufacturer will not accept any responsibility for accidents or damage resulting from not following the instructions in this manual.

2. DESCRIPTION OF THE MACHINE AND CONTENTS

Description of the machine (see Fig. 1)

1. Pump body
2. Pump handle
3. Inflow opening
4. De-aerating closure
5. Inflow opening
6. Outflow closure
7. Start/stop trigger
8. Power cord

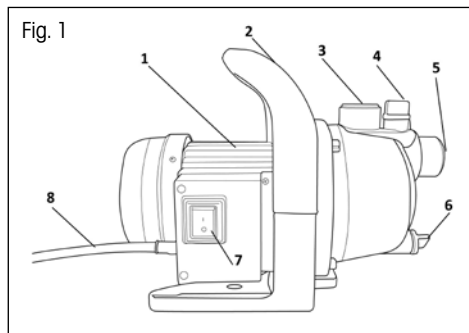

3. INSTALLATION AND RUNNING

⚠ WARNING! Before starting the installation, carefully read the complete documentation.

- ⚠ The pump must not be used in swimming pools, ponds, water tanks where there are people, even after pumping out hydrocarbons (fuel, diesel, heating oils, solvents) pursuant to the injury regulations valid for the stated area.
- ⚠ Never touch the water when the plug is inserted into the socket even if the pump is not running. Before each intervention, remove the plug from the electricity socket. Prevent dry running of the pump.
- ⚠ Protect the pump against atmospheric influences.
- ⚠ The pump is equipped with thermal engine protection. In the case of potential overloading of the engine, the protection system automatically disconnects the pump. The time required for cooling the engine varies between 15–20 minutes; after cooling, the pump is automatically activated.
- ⚠ After activating the protection system for the engine, it is necessary to identify and remove the reason.
- ⚠ Consult the paragraph "Identifying defects".
- ⚠ It is recommended to clean the pump before storing away. See the chapter "Maintenance and Cleaning".
- ⚠ Do not leave the pump running unattended.

Installation (Fig. 2.)

Garden pumps are recommended for small-scale agriculture in gardens and for gardening, emergency situations in households, and for use in hobbies. The compact form along with easy handling means they can also be used in special applications as portable pumps for emergency situations, such as pumping water from tanks.

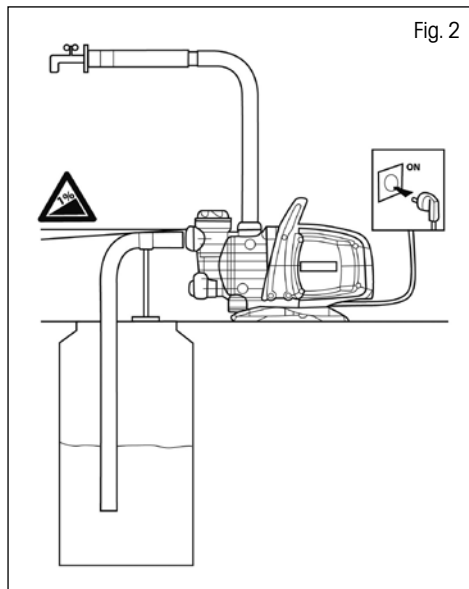

Fig. 2

- ✿ The pump must be installed in a place protected against bad weather and temperatures exceeding 40 °C.
- ✿ We recommend to firmly install the pump. The holes in legs enable to correct the firm base with bolts (the bolts are not included in the package), see Fig. 2.
- ✿ Prevent the piping from transferring excessive stress on top the input and output holes (point 3 and 5, Fig. 1), to prevent deformation or cracks.
- ✿ It is recommended to position the pump nearest to the pumped liquid; the pump must only be installed in a horizontal position.
- ✿ The piping must not have a smaller diameter than the diameter of the suction neck on the pump. For suction depths over four metres or with long horizontal sections, it is recommended to use a suction hose with a larger diameter than the suction hole for the pump.
- ✿ A slight declination of the suction hose in the upward direction of the pump will prevent the creation of air pockets. Fig. 2.
- ✿ If the suction piping is from rubber or a flexible material, always check that it has been reinforced and is resistant to vacuums to prevent narrowing due to suction.
- ✿ In the case of a firm installation, it is recommended to mount the stop valve on the side of the suction and on the side of the delivery. This enables to close the circuit on the input and/or on the output of the pump, which is useful when carrying out maintenance and cleaning or for a period when the pump is not used.
- ✿ When using in water with small dirt with small dimensions, it is recommended to use the filter on the input of the pump mounted on the suction tube.
- ✿ Do not make a large number of starts per hour. Do not exceed 20 starts/hour.

4. ELECTRICAL CONNECTION

- ✿ Check the voltage on the label on the electric engine of the pump with the supplied voltage; specifically, the ground terminal must be connected to the supply cable.
- ✿ The length of the supply cable, which is part of the pump, is restricted by the installation distance. If using an extension cable, make sure that it is of the same type (e.g. H05 RN-F or H07 RN-F, depending on the specific installation).

5. STARTING

- ✿ Do not start the pump without filling it with liquid.
- ✿ Fill the liquid into the output hole (Fig. 1, point 2) or the de-aerating hole (Fig. 1, point 3). Fill the liquid until it starts to overflow through the hole. The filling ensures the good function of the mechanical sealing. Dry operation of the pump causes damage to the mechanical sealing.
- ✿ It is then necessary to screw the de-aerating closure or to connect the hose.
- ✿ Insert the supply cable plug into an electricity socket with a voltage of 230 V.
- ✿ Run the pump with the main switch in position I (Fig. 1, point 7)
- ✿ Disconnect the pump by switching the switch into the position O
- ✿ In the case of exhausting the water source, immediately disconnect the pump by putting the main switch into the position O. Prevent dry running of the pump.

⚠ RISK OF FREEZING If the pump remains disconnected at a temperature lower than 0 °C, it is necessary to be sure that there is no water remaining which, in the case of freezing, could cause the plastic parts to crack.

- ✿ The remaining water can be discharged through the discharging hole (Fig. 1, point 6)
- ✿ If the pump is used with substances that can create sediments or with chlorinated water, rinse it after use with a strong stream of water to prevent the creation of sediments or incrustations??? which would have a tendency to reduce the parameters of the pump.





6. MAINTENANCE AND CLEANING

The pump does not require any type of maintenance. In all cases, repair and maintenance must only be carried out after disconnecting the pump from supply network. In the case of restarting the pump into operation, make sure that it is reassembled in the stated manner to prevent any risk to people.

7. WHAT TO DO "WHEN..."

MALFUNCTION	CHECKING (possible reasons)	SOLUTION
After starting, the engine is not turned on and there is no sound.	The supply socket is not under voltage.	Check the electricity supply.
	The engine of the pump is not under voltage.	Check the supply cable to the pump.
	Check protection.	If the circuit breakers are defective replace them with new ones.
	Potential intervention of thermal protection	Wait for approximately 20 mins for cooling engine. Check the reason which caused it and remove it. NOTE: A repeat of the failure means that there is short-circuit of the engine.
After starting, the engine does not turn but there is a sound.	Low supply voltage.	Check the supply voltage.
	Search for any blocking of the pump or engine.	Remove any mechanical resistance.
	Check whether the shaft is blocked.	Remove the cap using the tool and turn the shaft with a screwdriver.
	Check the condition of the condenser.	Replace the condenser.
The engine has difficulty running.	Make sure that the supply voltage is sufficient.	Check the supply voltage.
	Check any abrasion between the movable and fixed components.	Try to remove the reason for abrasion.
The pump does not supply any water.	The pump was not correctly filled.	Fill the pump with water and pay attention to any leaks of air by unscrewing the de-aerating closure.
	The suction tube has a sufficient diameter.	Replace the tube with another with a larger diameter.
The pump does not suck up the water.	Suction of water through the suction tube.	Remove the mentioned negative phenomenon by checking the tightness of the joints and refilling.
	A poor slope of the suction tube supports the creation of air bubbles.	Check the slope of the tube.
The pump is pumping an insufficient volume of water.	The suction tube is blocked.	Clean the suction tube.
	Running wheel is worn or blocked.	Remove the blockage or replace worn components.
	The diameter of the suction piping is insufficient.	Replace with piping with a larger diameter.
The pump vibrates and is noisy when running.	Check that the pump and piping are firmly fixed.	Secure any loose parts.
	Cavitation in the pump.	Decrease the height of the suction or check the decrease of pressure.
	The pump is overloaded.	It could be useful to restrict the inflow.

 **NOTE: Not covered by the warranty:**

-  Damage to the rotating mechanical gasket caused by running the pump empty, or by foreign objects in the water
-  Blocking the running of the wheel with foreign objects
-  Damage during transport
-  Damage caused by unprofessional alterations

8. TECHNICAL SPECIFICATIONS

Type	FVC 8010 EC	FVC 8020 EC
Voltage/Frequency	230 V ~ 50 HZ	230 V ~ 50 HZ
Power input	600 W	800 W
Maximum transferred amount	2,800 l/h	3,200 l/h
Maximum delivery	35 m	40 m
Maximum submersible depth	7 m	8 m
Maximum temperature of the media	35 °C)	35 °C)
Length of power cord	1.2 m	1.2 m
Maximum pressure	3.5 bar	4.0 bar
Connection of hose – suction	1", internal thread	1", internal thread
Connection of hose – outlet	1", internal thread	1", internal thread
Weight	6.5 kg	6.8 kg

9. DISPOSAL

INSTRUCTIONS AND INFORMATION REGARDING THE DISPOSAL OF USED PACKAGING MATERIALS

Dispose of used packaging material at a site designated for waste in your municipality.



The appliance and its accessories are manufactured from various materials, e.g. metal and plastic.

Take damaged parts to a recycling centre. Inquire at the relevant government department.



This appliance meets all the basic requirements of the relevant EU directives.

Changes in the text, design and technical specifications may be made without prior notice and we reserve the right to make these changes.

User manual in the original language.

FAST®

FAST ČR, a.s.

 Černokostecká 1621, 251 01 Říčany, Czech Republic
 tel.: +420 323 204 111, fax: +420 323 204 110

EU DECLARATION OF CONFORMITY

Product/ brand: Electric Submersible Pump/ **FIELDMANN**

Type/ model: **FVC 8010-EC** as factory model BGP-6002P
 AC 230V, 50Hz, 600W, IPX4, Class I

Manufacturer: FAST ČR, a.s.
 Černokostecká 2111, 100 00 Praha 10, Czech Republic
 VAT no: CZ26726548

The product is inline with directives and regulations listed below:

Directive LVD 2014/35/EU
 Directive EMC 2014/30/EU
 Directive RoHS 2011/65/EU

and norms:

EN 60335-1:2012+A11+A13
 EN 60335-2-41:2003+A1+A2
 EN 62233:2008
 EN 55014-1:2017
 EN 55014-2:2015
 EN 61000-3-2:2014
 EN 61000-3-3:2013



Place of issuance: Prague

Name: Ing. Zdeněk Pech
 Chairman of the Board

Date of issuance: 16. 1. 2020

Signature:

FAST® FAST ČR, a.s. ©
 Černokostecká 1621, 251 01 Říčany
 IČO: 26726548 tel.: +420/ 323 204 111
 DIČ: CZ26726548 fax: +420/ 323 204 110





 **FIELDMANN**[®]
Home & Garden Performance

Ovaj dokument je originalno proizveden i objavljen od strane proizvođača, brenda Fieldmann, i preuzet je sa njihove zvanične stranice. S obzirom na ovu činjenicu, Tehnoteka ističe da ne preuzima odgovornost za tačnost, celovitost ili pouzdanost informacija, podataka, mišljenja, saveta ili izjava sadržanih u ovom dokumentu.

Napominjemo da Tehnoteka nema ovlašćenje da izvrši bilo kakve izmene ili dopune na ovom dokumentu, stoga nismo odgovorni za eventualne greške, propuste ili netačnosti koje se mogu naći unutar njega. Tehnoteka ne odgovara za štetu nanесenu korisnicima pri upotrebi netačnih podataka. Ukoliko imate dodatna pitanja o proizvodu, ljubazno vas molimo da kontaktirate direktno proizvođača kako biste dobili sve detaljne informacije.

Za najnovije informacije o ceni, dostupnim akcijama i tehničkim karakteristikama proizvoda koji se pominje u ovom dokumentu, molimo posetite našu stranicu klikom na sledeći link:

<https://tehnoteka.rs/p/fieldmann-fvc-8010-ec-pumpa-za-vodu-akcija-cena/>