

Uputstvo za upotrebu (EN)

SENCOR blender SNB 4301RD

SENCOR

Tehnoteka je online destinacija za upoređivanje cena i karakteristika bele tehnike, potrošačke elektronike i IT uređaja kod trgovinskih lanaca i internet prodavnica u Srbiji. Naša stranica vam omogućava da istražite najnovije informacije, detaljne karakteristike i konkurentne cene proizvoda.

Posetite nas i uživajte u ekskluzivnom iskustvu pametne kupovine klikom na link:

<https://tehnoteka.rs/p/sencor-blender-snb-4301rd-akcija-cena/>

Nutri Blender

User's manual

EN



SENCOR®

SNB 4300WH
SNB 4301RD
SNB 4302SS
SNB 4303BK

Prior to using this appliance, please read the user's manual thoroughly, even in cases, when one has already familiarised themselves with previous use of similar types of appliances. Only use the appliance in the manner described in this user's manual. Keep this user's manual in a safe place where it can be easily retrieved for future use.

We recommend saving the original cardboard box, packaging material, purchase receipt and responsibility statement of the vendor or warranty card for at least the duration of the legal liability for unsatisfactory performance or quality. In the event of transportation, we recommend that you pack the appliance in the original box from the manufacturer.

TABLE OF CONTENTS

IMPORTANT SAFETY INSTRUCTIONS	3
DESCRIPTION OF THE APPLIANCE	6
PURPOSE OF USE	7
BEFORE FIRST USE	7
ASSEMBLING AND DISASSEMBLING THE APPLIANCE	7
OPERATING THE APPLIANCE	8
QUICK GUIDE TO PROCESSING INGREDIENTS.....	9
TROUBLESHOOTING.....	10
CLEANING AND MAINTENANCE.....	10
STORAGE.....	11
TECHNICAL SPECIFICATIONS	12
INSTRUCTIONS AND INFORMATION REGARDING THE DISPOSAL OF USED PACKAGING MATERIALS	12
DISPOSAL OF USED ELECTRICAL AND ELECTRONIC EQUIPMENT.....	12

IMPORTANT SAFETY INSTRUCTIONS

READ CAREFULLY AND STORE FOR FUTURE USE.

- This appliance may be used by persons with physical or mental impairments or by inexperienced persons, if they are properly supervised or have been informed about how to use the appliance in a safe manner and understand the potential dangers.
- Children must not use this appliance or play with it. Keep this appliance and the power cord out of reach of children.
- The appliance is intended for household use and is designed for processing a standard amount of food in the household.
- Before connecting this appliance to a power socket, make sure the voltage stated on its rating label corresponds to the voltage in your power socket. We do not recommend using an extension cord.
- Do not use the appliance in an industrial environment or outdoors.
- Do not place the appliance on an electric or gas stove or in its vicinity, on a kitchen sink drainboard, on the edge of a table or on an unstable surface. Only place the appliance on an even, dry and stable surface.
- Only use the appliance with the original accessories that came with it.
- Do not use the appliance for any other purposes than those for which it is intended.



Warning:

Improper use can lead to injury.

- Make sure that the appliance is correctly assembled before putting it into operation.
- Pay increased attention when handling hot liquids because they may release steam or they could spray and cause burns. Allow hot liquids and foodstuffs to cool down to a temperature of at least 45 °C before putting them into the blending jar and blending them.

Nutri Blender

SNB 4300WH / SNB 4301RD / SNB 4302SS / SNB 4303BK

- Do not leave the appliance in continuous operation for longer than 1 minute. Before turning it on again, allow it to cool down for at least 3 minutes.
- The appliance is equipped with a thermal fuse protecting the motor from damage in case of overload. If automatic shut-off of the appliance occurs in consequence of motor overload, disconnect it from the network socket and let it cool for at least 30 minutes. Then bring the appliance back into operation.
- If ingredients stick to the blade assembly or inside walls of the blending jar, turn the appliance off and unplug it from the power supply. Make sure that the blade assembly has stopped rotating. Take the blending jar assembly off the motor unit and turn it over so that the blade assembly points upwards. Remove the blade assembly. Use a plastic spatula to clean the blade assembly and the walls of the blending jar. Reassemble the blending jar and mount it back on the motor unit. Plug the power cord into a power socket and continue blending.
- When handling the blade assembly, when taking it out of the blending jar and when cleaning it, take special care to avoid injury on the blades. Always hold the blade unit by the bottom plastic part. Do not attempt to sharpen the blades.
- The blender accessories are not intended to be heated in a microwave oven. Do not expose the blending jar to extreme temperature changes.
- Do not turn on the appliance when it is empty. The incorrect use of the appliance may negatively affect its lifetime.
- Always turn off the appliance and disconnect it from the power socket if you will not be using it and if you will be leaving it without supervision, before assembly, disassembly, replacing accessories and before cleaning or moving it.
- Check that the motor unit is turned off, disconnected from the power socket and that the rotating parts have come to a complete stop before removing the blending jar from the motor unit.



CAUTION:

DO NOT OPEN UNTIL BLADES STOP.

- Do not submerge the motor unit and its power cord in water or any other liquid, or wash these parts under running water.
- Ensure that the power plug contacts do not come into contact with moisture. Do not place heavy items on the power cord. Make sure the power cord does not hang over the edge of a table or that it does not touch a hot surface.
- Do not disconnect the appliance from the power socket by pulling on the power cord. This could damage the power cord or the power socket. Disconnect the cord from the power socket by gently pulling on the plug of the power cord.
- If the power cord is damaged, have it replaced at a professional service centre. It is forbidden to use the appliance if it has a damaged power cord or plug.
- Do not use the appliance when it is not functioning properly or showing any signs of damage.
- In order to prevent a hazardous situation arising, do not repair the appliance yourself or modify it in any way. Have all repairs or adjustments performed at an authorised service centre. By tampering with the appliance, you risk voiding your legal rights arising from unsatisfactory performance or quality warranty.

Nutri Blender

SNB 4300WH / SNB 4301RD / SNB 4302SS / SNB 4303BK

DESCRIPTION OF THE APPLIANCE

A

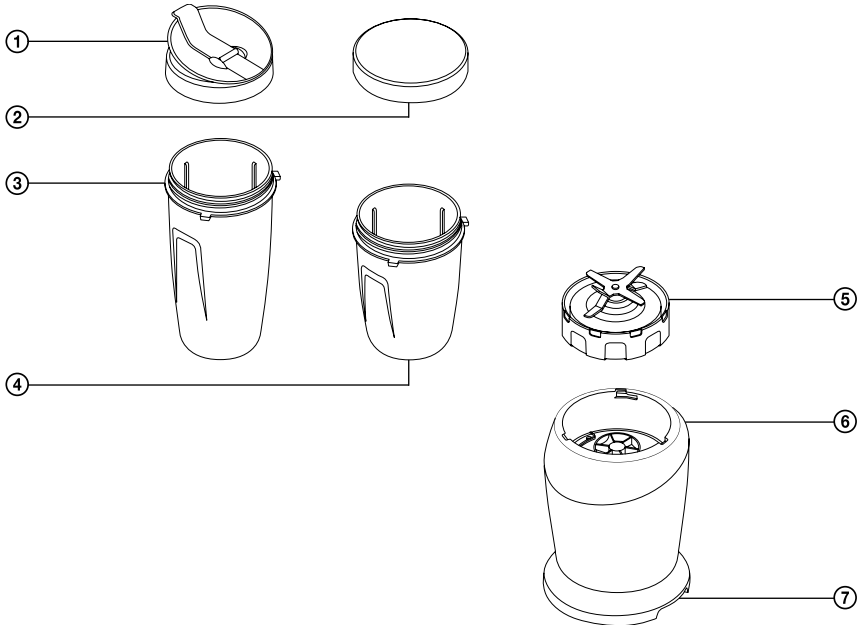

- ① Screw-on cap with a closable drinking spout can be screwed on to both bottles.
- ② Screw-on cap without a drinking spout can be screwed on to both bottles.
- ③ Large 1 l blending jar made from quality BPA-free plastic. It also serves as a drinking bottle.
- ④ Small 800 ml blending jar made from quality BPA-free plastic. It also serves as a drinking bottle.
- ⑤ Blade assembly with four quality stainless steel blades
- ⑥ Motor unit
- ⑦ Anti slip feet are located on the bottom of the motor unit.

PURPOSE OF USE

This nutri blender is ideal for making fresh fruit or fitness beverages, milkshakes and other cocktails, mixed drinks, outstanding salsas, creamy soups, sauces, blended baby food and it may also be used for blending ice. It is equipped with a single four-blade assembly made from quality stainless steel and two sizes of blending jars. The blending jars are made from quality durable plastic that does not contain the toxic hydrocarbon BPA (Bisphenol A) and they can also serve as convenient drink bottles. Both bottles can be closed with a cap with or without a drinking spout for comfortable carrying without risking spilling the beverage. Its anti-slip feet provide excellent stability to the blender during its operation. The bottles, caps and the blade assembly can be safely washed in the top rack of a dishwasher.

BEFORE FIRST USE

1. Take the appliance and its accessories out of the packaging materials.
2. Thoroughly wash all parts intended for contact with food (large and small blending jars A③ and A④, caps A① and A② and the blade assembly A⑤), using warm water and a neutral kitchen detergent. Then rinse with clean water and allow these parts to dry naturally or dry them out thoroughly using a wiping cloth. All removable parts can also be safely washed in the top rack of a dishwasher.



Attention:

When cleaning the blade assembly A⑤ take special care to avoid injury. The blades A⑤ are sharp.

The blade assembly A⑤ has a gasket seal to ensure that the blending jar remains air-tight during the blending process. If the blade assembly A⑤ is washed in a dishwasher, this gasket seal may come loose due to heat. After washing the blade assembly A⑤, always check that the gasket seal is in its place.

ASSEMBLING AND DISASSEMBLING THE APPLIANCE

- Before you start assembling or disassembling the appliance, check that the motor unit A⑥ is turned off and disconnected from the power socket and that the rotating parts have come to a complete stop.

1. Assembling and disassembling the blender

- 1.1 Turn the blending jar A③ or A④ over so that the neck points upwards.
- 1.2 Check that the gasket seal on the blade assembly A⑤ is in its place. Place the blade assembly A⑤ on to the neck of the blending jar A③ or A④ so that the blades point inwards and screw it clockwise on to the neck of the blending jar A③ or A④.



Note:

Place the ingredients into the blending jar A③ or A④ before attaching it to the blade assembly A⑤. When filling the blending jar A③ or A④ do not exceed the MAX mark.

- 1.3 Turn the blending jar assembled in this way over so that the blade assembly A⑤ points downwards and insert it into the motor unit A⑥ so that the tabs along the outer perimeter of the blending bottle slide into the slots on the motor unit A⑥.

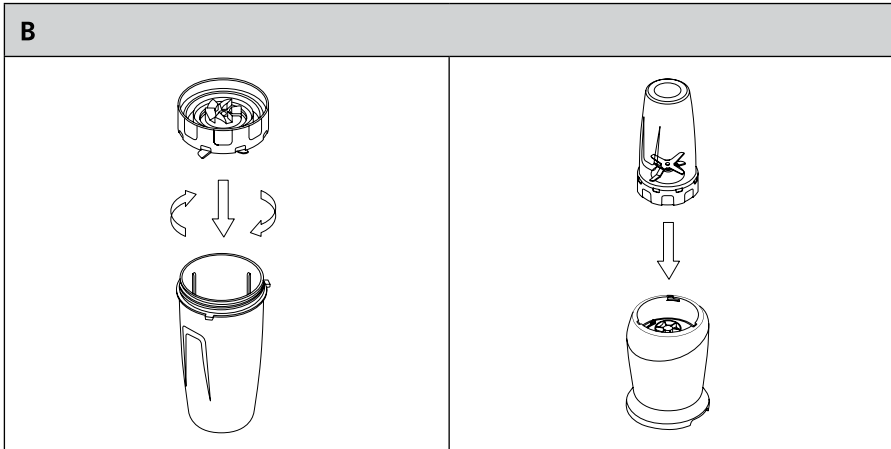

1.4 To disassemble, proceed in the reverse sequence.

2. Assembling the bottle

To close the bottle A③ or A④ you may use the cap A① or A②. Always properly tighten the cap A① or A② to prevent the bottle's contents from leaking out. When using cap A①, make sure that the drinking spout is properly closed so as not to spill the bottle's contents when carrying it.

OPERATING THE APPLIANCE

- 1.1 Make sure that the motor unit A⑥ is disconnected from the power socket.
- 1.2 Add the ingredients that you wish to blend into the blending jar A③ or A④. The maximum amount of ingredients that can be put into the blending jar A③ and A④ is marked by the MAX mark. Do not overfill the blending jar A③ and A④ with food or liquids.



Attention:

Allow hot liquids and foodstuffs to cool down to a temperature of at least 45 °C before putting them into the blending jar A③ or A④ and blending them.



Note:

Some liquids gain volume during the blending process.

- 1.3 Assemble the blending jar according to the instructions in the chapter Assembling and disassembling the appliance. Turn the assembled blending jar over so that the blade assembly A⑥ points downwards and insert it into the motor unit A⑥ so that the tabs along the outer perimeter of the blending bottle slide into the slots on the motor unit A⑥.
- 1.4 Connect the motor unit A⑥ to a power socket. To start the blender, rotate the assembled blending jar clockwise. The blender is equipped with a safety mechanism that will prevent it from being started unless the blending jar assembly is properly attached to the motor unit A⑥.

Nutri Blender

SNB 4300WH / SNB 4301RD / SNB 4302SS / SNB 4303BK

EN



Attention:

The maximum operating time is 1 minute. Do not leave the appliance in continuous operation for longer than indicated above. Then allow the appliance to cool down for 3 minutes. When processing dry ingredients, do not leave the appliance in continuous operation for longer than 30 seconds.

- 1.5 If ingredients are getting stuck on the blade assembly A⑤ or on the walls of the blending jar A③ or A④, turn the blender off by turning the blending jar A③ or A④ anticlockwise and disconnect the motor unit A⑥ from the power socket. Make sure that the blade assembly A⑤ has stopped rotating. Take the blending jar assembly off the motor unit A⑥ and turn it over so that the blade assembly A⑤ points upwards. Screw off the blade assembly A⑤. Use a plastic spatula to clean the blade assembly A⑤ and the walls of the blending jar A③ or A④. Reassemble the blending jar and insert it back into the motor unit A⑥. Plug the power cord into a power socket, rotate the blending jar clockwise and continue blending.
- 1.6 To stop the blender, rotate the blending jar anticlockwise. Disconnect the power cord from the power socket. Check that the blade assembly A⑤ has stopped rotating and take the blending jar assembly off the motor unit A⑥.
- 1.7 Turn the blending jar A③ or A④ over so that the blade assembly A⑤ points upwards. Take off the blade assembly A⑤ and as required, close the blending jar A③ or A④ with the cap A① or A② or pour its contents into another suitable container.
- 1.8 Then clean all used parts according to the instructions in chapter Cleaning and maintenance.

QUICK GUIDE TO PROCESSING INGREDIENTS

- First cut food with a firm consistency such as fruit and vegetables into smaller pieces measuring 2 to 3 cm and only then blend it.

Ingredients	Recommended blending time
Fruit and vegetables cut into smaller pieces	30 s
Smoothies and cocktails	40 s
Salsa	30 s
Soups	30 s
Baby food	40 s



Note:

The above food processing times are only a reference. The actual blending time depends on the size of the ingredients, their amount and the required final consistency.

TROUBLESHOOTING

Problem	Possible solution
The blender does not start.	<p>The motor unit A⑥ is not connected to a power source. Plug it into a power socket.</p> <p>The blending jar assembly is not correctly inserted into the motor unit A⑥. When inserting the blending jar A③ or A④ into the motor unit A⑥, ensure that the tabs on the perimeter of the jar slides into the corresponding slots in the motor unit A⑥. To start the blender, rotate the blending jar assembly clockwise.</p>
The blending jar assembly is leaking	Check that the gasket seal on the blade assembly A⑤ is in its place. Seat the blade assembly A⑤ on to the blending jar A③ or A④ and screw it in properly in the clockwise direction.
Ingredients are blended unevenly.	Too many ingredients are processed at the one time. Process the ingredient in smaller batches and run the blender repeatedly in short intervals.
Ingredients are blended too finely.	Blending time is too long. To achieve optimal results, blend the ingredients in short bursts and repeatedly.
The blending result is unsatisfactory.	Process the ingredient in smaller batches and run the blender repeatedly in short intervals. Blend frozen ingredients in 2 to 5 second intervals.
Unsuccessful in blending ice cubes.	Ice cubes must be blended immediately upon being removed from the freezer. Otherwise, they will start melting, stick together and cannot be blended. Make sure that the blending jar A③ or A④ is completely dry before placing ice cubes into it. Blend the ice cubes in short bursts and repeatedly.
Blender cannot be turned off.	If the blender cannot be turned off by rotating the blending jar assembly anticlockwise, disconnect the power cord from the power socket and contact an authorised service centre.

CLEANING AND MAINTENANCE

- Before cleaning it, make sure that the appliance is turned off and disconnected from the power socket. Make sure the rotating parts have stopped and remove the assembled blending jar from the motor unit A⑥ .
- Remove the blade assembly A⑤ from the blending jar A③ or A④ and thoroughly wash the individual parts in warm water using neutral kitchen detergent. Then rinse them under clean running water and wipe them dry with a fine wiping cloth or allow them to dry naturally. If you used the cap A① or A②, clean it out in the same way. Removable parts can also be safely washed in the top rack of a dishwasher. To thoroughly clean out the blade assembly A⑤, you can use a fine nylon brush.

Nutri Blender

SNB 4300WH / SNB 4301RD / SNB 4302SS / SNB 4303BK

EN



Attention:

When removing and cleaning the blade assembly A⑤ take special care to avoid injury. The edges on the blade assembly A⑤ are sharp.

The blade assembly A⑤ has a gasket seal to ensure that the blending jar remains air-tight during the blending process. If the blade assembly A⑤ is washed in a dishwasher, this gasket seal may come loose due to heat. After washing the blade assembly A⑤, always check that the gasket seal is in its place.

Certain foods may cause discolouration of the blending jar A③ or A④. However, this does not have any effect on the functionality of the appliance.

- We recommend that you always wash the accessories immediately after use to prevent the ingredients from drying on. Ingredients that have dried on, are more difficult to remove. To remove dried on ingredients, you may start the blender with the blending jar A③ or A④ filled up to $\frac{2}{3}$ with warm water. If the dried on ingredients are not released, repeat the procedure.
- To clean the outer surface of the motor unit A⑥, use a cloth dipped in a weak detergent solution. After applying the kitchen detergent, wipe the surface with a cloth lightly dampened in clean water and then wipe dry.
- Never submerge the motor unit A⑥ or the power cord in water or in any other liquid. Do not use thinners or solvents or cleaning agents causing abrasion to clean the appliance. Otherwise, the surface of the appliance may be damaged.

STORAGE

- When not using the appliance, store it in a dry place out of children's reach. We recommend that you keep the blade assembly A⑤ attached to the blending jar A③ or A④ to avoid injury caused by the blades being touched.



Caution:

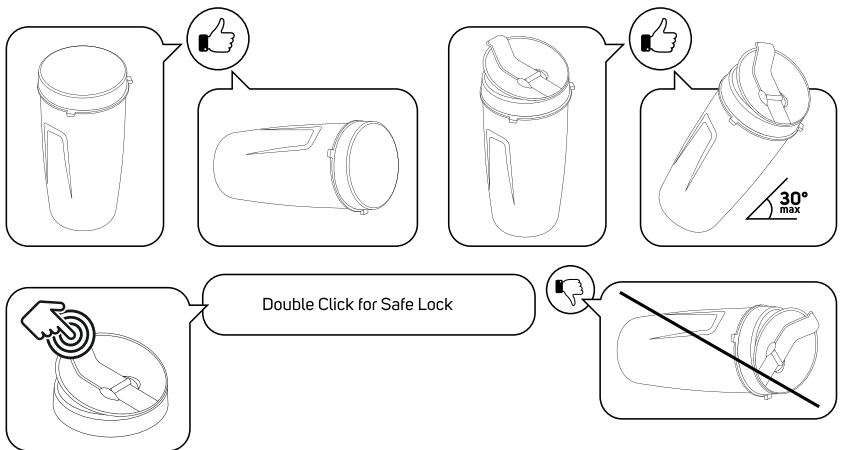

TECHNICAL SPECIFICATIONS

Rated voltage range	220–240 V
Rated frequency.....	50/60 Hz
Rated power input.....	1 000–1 200 W
Safety class (for electric shock protection)	II
Noise level.....	95 dB(A)

The declared noise emission level of the appliance is 95 dB(A), which represents a level A of acoustic power with respect to a reference acoustic power of 1 pW.

We reserve the right to change text and technical specifications.

INSTRUCTIONS AND INFORMATION REGARDING THE DISPOSAL OF USED PACKAGING MATERIALS

Dispose of used packaging material at a site designated for waste in your municipality.

DISPOSAL OF USED ELECTRICAL AND ELECTRONIC EQUIPMENT



This symbol on products or original documents means that used electric or electronic products must not be added to ordinary municipal waste. For proper disposal, renewal and recycling hand over these appliances to determined collection points. Alternatively, in some European Union states or other European countries you may return your appliances to the local retailer when buying an equivalent new appliance.

Correct disposal of this product helps save valuable natural resources and prevents potential negative effects on the environment and human health, which could result from improper waste disposal. Ask your local authorities or collection facility for more details.

In accordance with national regulations penalties may be imposed for the incorrect disposal of this type of waste.

For business entities in European Union states

If you want to dispose of electric or electronic appliances, ask your retailer or supplier for the necessary information.

Disposal in other countries outside the European Union.

This symbol is valid in the European Union. If you wish to dispose of this product, request the necessary information about the correct disposal method from the local council or from your vendor



This appliance meets all the basic requirements of EU directives related to it.

Ovaj dokument je originalno proizveden i objavljen od strane proizvođača, brenda Sencor, i preuzet je sa njihove zvanične stranice. S obzirom na ovu činjenicu, Tehnoteka ističe da ne preuzima odgovornost za tačnost, celovitost ili pouzdanost informacija, podataka, mišljenja, saveta ili izjava sadržanih u ovom dokumentu.

Napominjemo da Tehnoteka nema ovlašćenje da izvrši bilo kakve izmene ili dopune na ovom dokumentu, stoga nismo odgovorni za eventualne greške, propuste ili netačnosti koje se mogu naći unutar njega. Tehnoteka ne odgovara za štetu nanесenu korisnicima pri upotrebi netačnih podataka. Ukoliko imate dodatna pitanja o proizvodu, ljubazno vas molimo da kontaktirate direktno proizvođača kako biste dobili sve detaljne informacije.

Za najnovije informacije o ceni, dostupnim akcijama i tehničkim karakteristikama proizvoda koji se pominje u ovom dokumentu, molimo posetite našu stranicu klikom na sledeći link:

<https://tehnoteka.rs/p/sencor-blender-snb-4301rd-akcija-cena/>