

Uputstvo za upotrebu (EN)

PHANTEKS Glacier One 360D30 White PH-GO360D30_DWT01 vodeno hlađenje



Tehnoteka je online destinacija za upoređivanje cena i karakteristika bele tehnike, potrošačke elektronike i IT uređaja kod trgovinskih lanaca i internet prodavnica u Srbiji. Naša stranica vam omogućava da istražite najnovije informacije, detaljne karakteristike i konkurentne cene proizvoda.

Posetite nas i uživajte u ekskluzivnom iskustvu pametne kupovine klikom na link:

https://tehnoteka.rs/p/phanteks-glacier-one-360d30-white-ph-go360d30_dwt01-vodeno-hladjenje-akcija-cena/

INSTRUCTIONS

Thank you for choosing Phanteks. Please take a moment to carefully go through the manual. This manual will walk you through all the installation steps of the Glacier One D30.

This manual is for the following models:

- GLACIER ONE 240 D30
- GLACIER ONE 360 D30
- GLACIER ONE 420 D30

 Phanteks will not take responsibility for any damages incurred due to incorrect installation or usage of this product.



GLACIER ONE D30

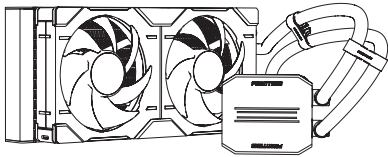

GLACIER ONE D30-240
1x 240 Radiator
2x D30-120mm Fans

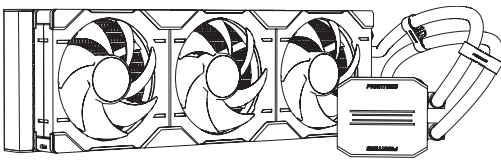

GLACIER ONE D30-360
1x 360 Radiator
3x D30-120mm Fans

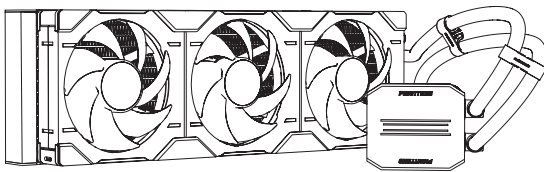

GLACIER ONE D30-420
1x 420 Radiator
3x D30-140mm Fans

ACCESSORIES



3-PIN D-USB MOTHERBOARD ADAPTER
1x 600mm

SATA TO 2-PIN PUMP ADAPTER
1x



PH-NDC THERMAL COMPOUND
1x



TUBE CLIPS
3x

MOUNTING HARDWARE

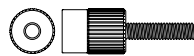

AM4 | AM5 STAND-OFF
4x

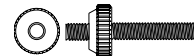

TR4 STAND-OFF
(360 MODELS ONLY)
4x

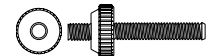

INTEL 2011 | 2066 STAND-OFF
4x

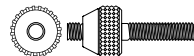

INTEL 1700 STAND-OFF
4x

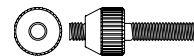

INTEL 115X | 1200 STAND-OFF
4x

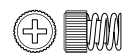

THUMB NUTS
4x



33mm RADIATOR SCREWS
8x | 12x 6-32 UNC

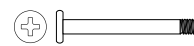

35mm RADIATOR SCREWS
8x | 12x 6-32 UNC



6mm RADIATOR SCREWS
8x | 12x 6-32 UNC

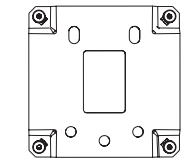

INTEL 115X | 1200 | 1700 BACKPLATE
1X

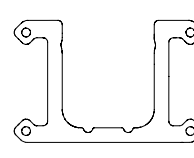

AMD AM4 | AM5 BRACKET
(INTEL BRACKET IS PRE-INSTALLED)
1X

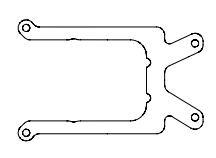

AMD TR4 BRACKET
(360 & 420 MODELS ONLY)
1X

D30 ACCESSORIES

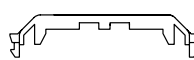

BRIDGE CLIP
1x | 2x

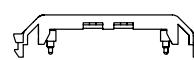

BRIDGE CLIP CONNECTOR
1x | 2x



CORNER CLIP CABLE
1x



CORNER CLIP
3x

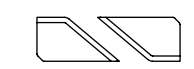

SCREW COVER CORNER
2x each

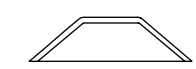

SCREW COVER BRIDGE
2x | 4x

GLACIER ONE D30

1. PREPARE MOTHERBOARD

Follow instructions for the corresponding socket.

INTEL 115X | 1200 | 1700

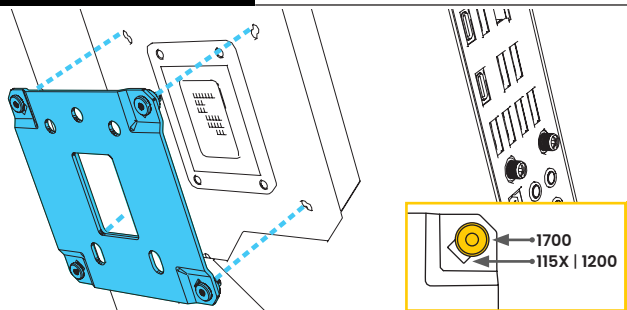

Insert the backplate through the motherboard.

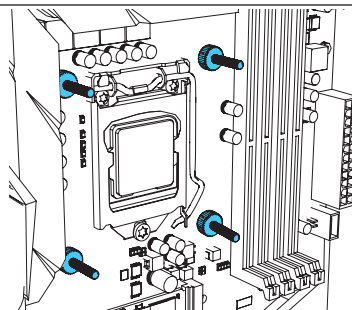

Secure the backplate with the 4x Stand-offs. Make sure to use the correct socket stand-off.

PROCEED TO STEP 2. >

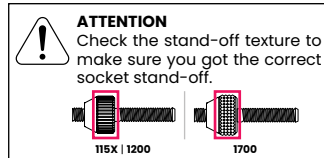
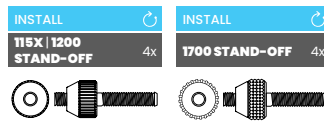

INTEL 2011 | 2066

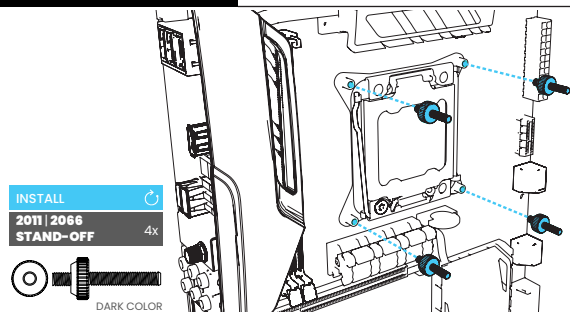

Secure the 4x Intel 2011 | 2066 Stand-offs to the motherboard.

PROCEED TO STEP 2. >

AMD AM4 | AM5

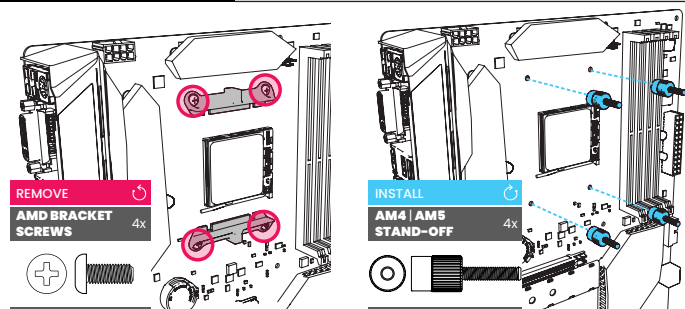

Remove the stock mounting brackets.

Secure the 4x AM4/AM5 Stand-offs to the motherboard.

PROCEED TO STEP 2. >

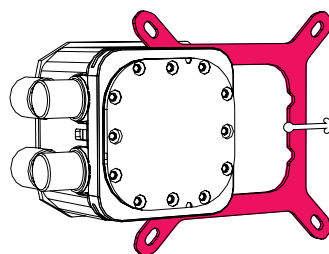

Remove the pre-installed Intel bracket first by sliding it off the cooling module.

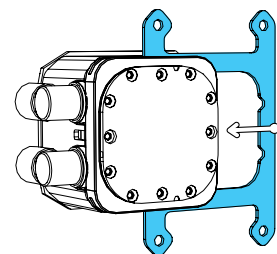

Attach the AM4/AM5 bracket by sliding it on the cooling module.

AMD TR4

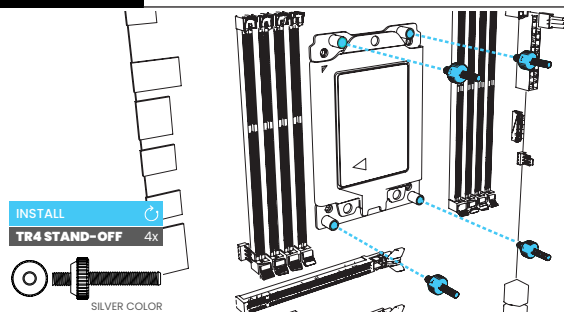

Secure the 4x TR4 Stand-offs to the motherboard.

PROCEED TO STEP 2. >

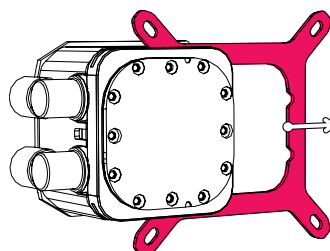

Remove the pre-installed Intel bracket first by sliding it off the cooling module.

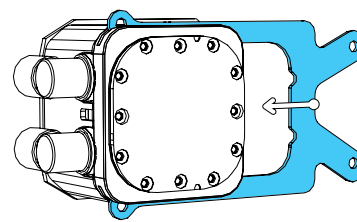

For the AMD TR4 socket, slide the bracket on the cooling module.

2. INSTALLING THE CPU BLOCK

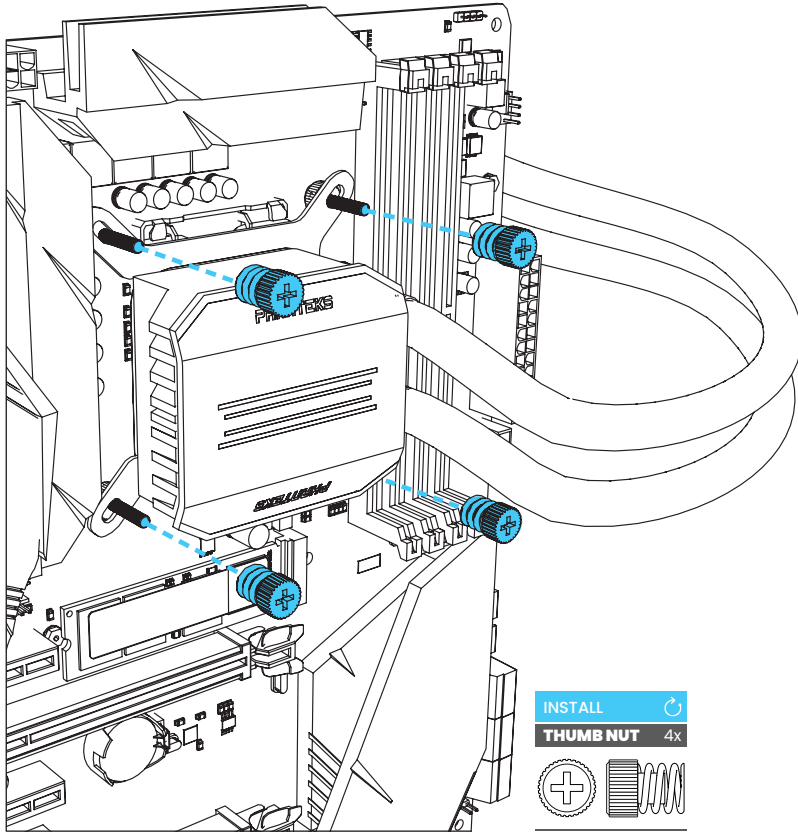

Secure the CPU block to the stand-offs on the motherboard with the 4x thumb nuts.



PRO TIP

The thermal compound is pre-applied. More thermal compound is included for future installations.

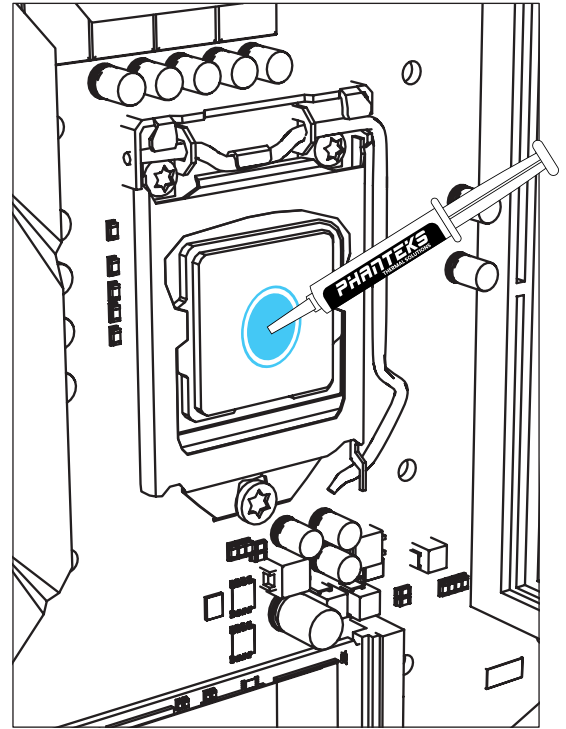

3. PREPARE D30 FANS



ATTENTION

Make sure to read and follow all the steps in the D30-120 manual for correct installation.

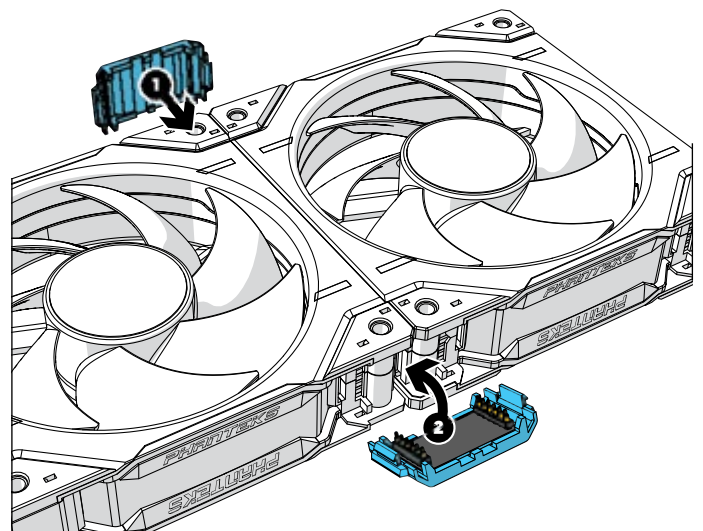
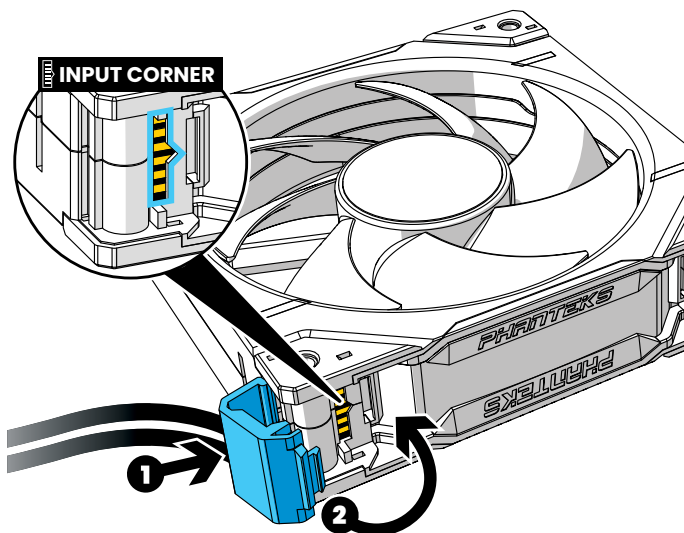

GLACIER ONE D30

4. MOUNT THE RADIATOR AND FANS

We recommend to install the fans to the radiator before mounting it into the chassis. Three types of screws are included to mount the radiator and the fans in different options.

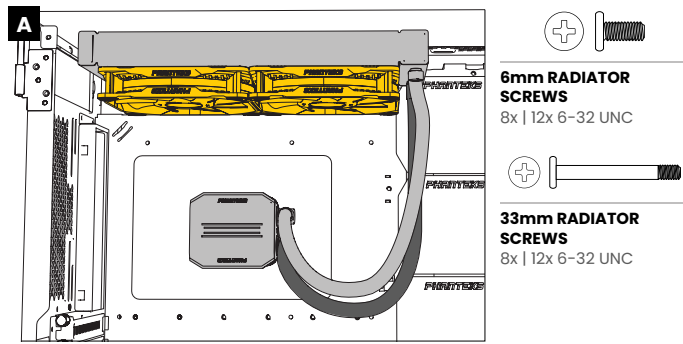

Use the 30mm radiator screws to mount fans to the radiator and the 6mm screws to to mount the radiator directly to the chassis.

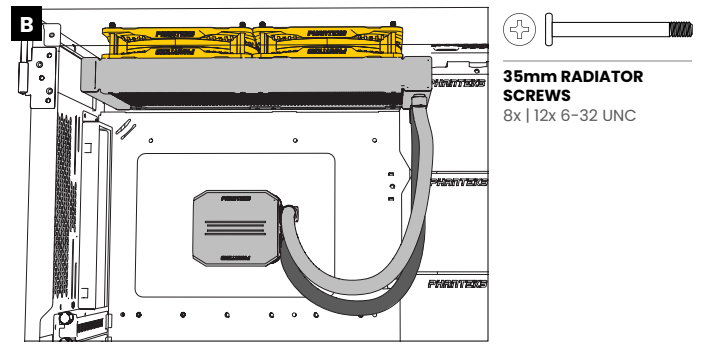

Use the 35mm radiator screws to mount the fan to the radiator and chassis.

5. CONNECT PUMP CABLE

PUMP CABLE

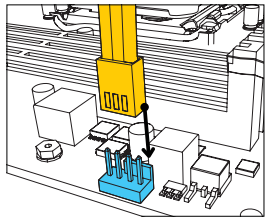

3 or 4-pin pump cable

Connect the pump cable to an available 3 or 4-pin header on the motherboard (pump header if available). Alternatively, you can use the included SATA to pump adapter to power the pump directly from the PSU.

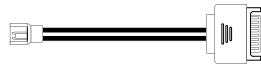

7. INSTALL TUBE CLIPS

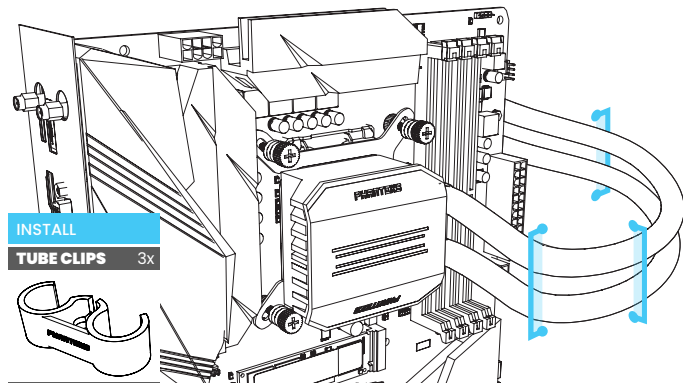

Install the (3x) included Tube Clips for a tidy tube routing. Simply snap the clips on the tubes.



PRO TIP

Fan cables can be routed through the middle of the Tube Clips.

SUPPORT & WARRANTY

As a Phanteks customer, you are priority number one for us. We have a dedicated team across the globe to deliver the experience you deserve. If you have any issues with the products, please don't hesitate to contact our customer care team.

RMA and Technical Support Americas

Hours: Monday-Friday 9:00-5:00 PST
Phone number: +1(909)598-2115
Email: support@phanteksusa.com
Facebook: @Phanteks

RMA and Technical Support International

Email: support@phanteks.com
Facebook: @Phanteks

For spare parts and optional upgrades please visit:
www.axperterc.com (EU) | www.phanteksusa.com (US)



6. CONNECT D-RGB

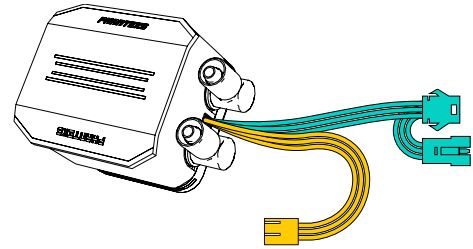

D-RGB CONTROL

The D-RGB pump and fan lighting need a controller to function. Connect to an ARGB-equipped motherboard with the included D-RGB Motherboard adapter or use a Phanteks D-RGB Controller. The Phanteks D-RGB Controller is sold separately (PH-CTHUB_DRGB_01)

MOTHERBOARD CONTROL

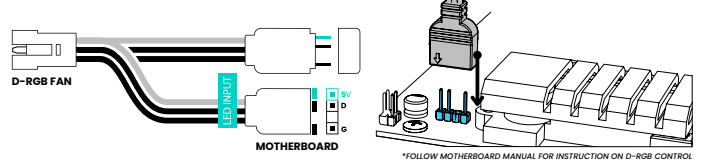

D-RGB EXPANSION

More Phanteks D-RGB lighting products can be daisy-chained easily with the JST-connector.

PHANTEKS D-RGB CONTROLLER

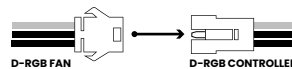

CONNECT TO THE D-RGB CONTROLLER WITH JST CONNECTOR.

EXPAND WITH MORE D-RGB PRODUCTS

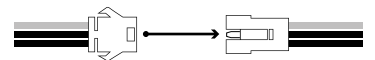

DAISY-CHAIN PHANTEKS D-RGB PRODUCTS TOGETHER WITH THE JST-CONNECTOR.

Ovaj dokument je originalno proizveden i objavljen od strane proizvođača, brenda PHANTEKS, i preuzet je sa njihove zvanične stranice. S obzirom na ovu činjenicu, Tehnoteka ističe da ne preuzima odgovornost za tačnost, celovitost ili pouzdanost informacija, podataka, mišljenja, saveta ili izjava sadržanih u ovom dokumentu.

Napominjemo da Tehnoteka nema ovlašćenje da izvrši bilo kakve izmene ili dopune na ovom dokumentu, stoga nismo odgovorni za eventualne greške, propuste ili netačnosti koje se mogu naći unutar njega. Tehnoteka ne odgovara za štetu nanесenu korisnicima pri upotrebi netačnih podataka. Ukoliko imate dodatna pitanja o proizvodu, ljubazno vas molimo da kontaktirate direktno proizvođača kako biste dobili sve detaljne informacije.

Za najnovije informacije o ceni, dostupnim akcijama i tehničkim karakteristikama proizvoda koji se pominje u ovom dokumentu, molimo posetite našu stranicu klikom na sledeći link:

https://tehnoteka.rs/p/phanteks-glacier-one-360d30-white-ph-go360d30_dwt01-vodeno-hladjenje-akcija-cena/