

## Uputstvo za upotrebu (EN)

LIAN LI kućište O11 Vision belo



Tehnoteka je online destinacija za upoređivanje cena i karakteristika bele tehnike, potrošačke elektronike i IT uređaja kod trgovinskih lanaca i internet prodavnica u Srbiji. Naša stranica vam omogućava da istražite najnovije informacije, detaljne karakteristike i konkurentne cene proizvoda.

Posetite nas i uživajte u ekskluzivnom iskustvu pametne kupovine klikom na link:

<https://tehnoteka.rs/p/lian-li-kuciste-o11-vision-belo-akcija-cena/>

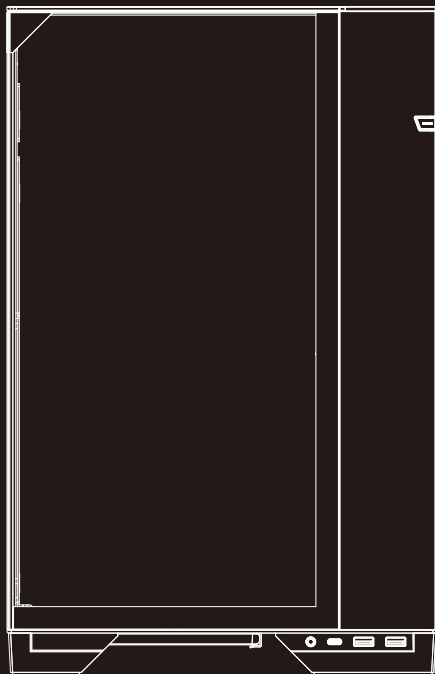

# 011 VISION

ENVISION THE PC

---

Installation Guide / 安裝說明書 /  
Guide d'installation / Installationsanleitung /  
Guía de instalación / インストールガイド

## Remove the side panel, top glass and side glass

卸下側板、上玻璃與側玻璃 / Retirez le panneau latéral, le vitrage supérieur et le vitrage latéral / Entfernen Sie das Seitenteil, das oberseitige Glas und das seitliche Glas / Retire el panel lateral, el vidrio superior y el vidrio lateral / サイドパネル、トップガラス、サイドガラスを取り外してください

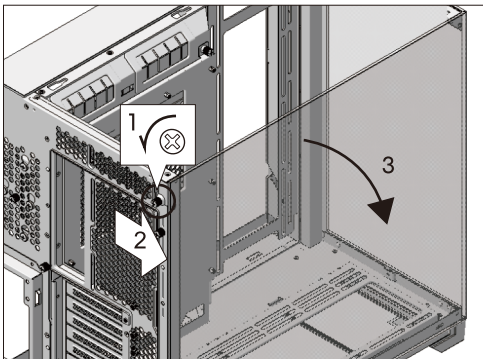
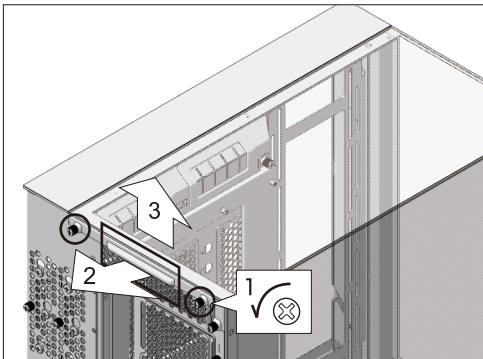
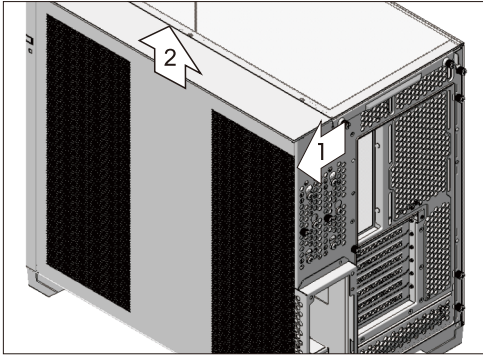

**⚠ No need to remove the front glass panel during regular assembly**  
 一般裝配不需拆卸前玻璃 / Pas besoin de retirer la vitre avant lors de l'assemblage régulier / Während der regulären Montage muss die vordere Glasscheibe nicht entfernt werden / No es necesario quitar el vidrio frontal durante el montaje regular / 常の組み立て時には、前面のガラスを取り外す必要はありません

Remove the front glass panel / 卸下前玻璃 / Retirez la vitre avant / Entfernen Sie das Frontglas / Quitar el cristal frontal / フロントガラスを外します

**⚠ No need to remove the front glass during usual installation process / 此螺絲一定要卸下，避免支架變形 / Pas besoin de retirer la vitre avant pendant le processus d'installation habituel**

1. Remove the protecting clip / 移除保護膠條 / Retirez le clip de protection.
2. Peel off the protective film on both sides / 撕掉玻璃兩面的保護膜 / Décollez le film protecteur des deux côtés.
3. Recommend to keep the protecting clip on for transportation / 如常運送建議將保護膠條裝上 / Il est recommandé de conserver le clip de protection pour le transport.

## Case components

機殻部品紹介 / Composants du boîtier / Gehäusekomponenten / Componentes de la caja / ケースのコンポーネント

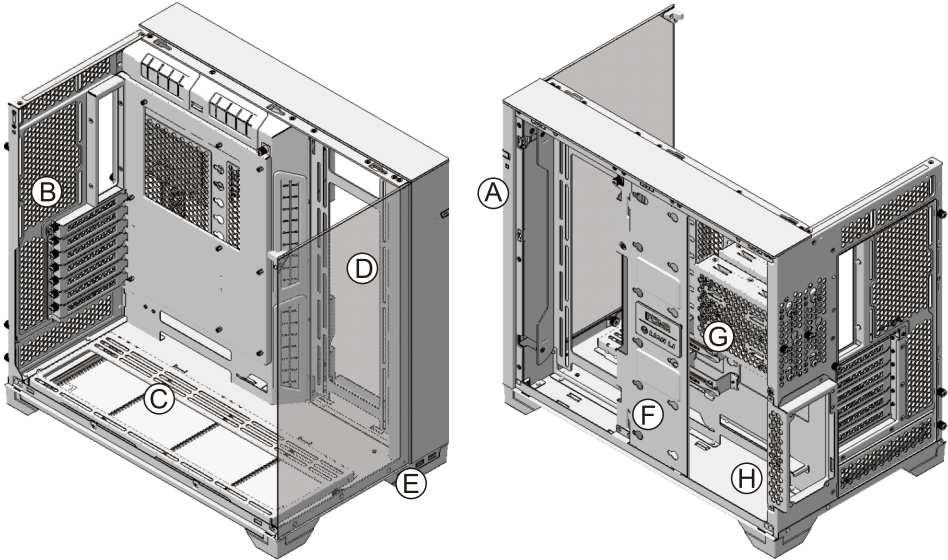

(A) Power Button/ Reset Button

(B) Motherboard High Mode: 120 mm fan x 1  
Motherboard Low Mode: 120 mm fan x 2 or 240 mm radiator x 1

(C) Removable fan bracket,  
Support 120 mm fan X 3 or 140 mm fan X 3 or 360 mm radiator X 1 or 280 mm radiator X 1

(D) Removable fan bracket,  
Support 120 mm fan X 3 or 140 mm fan X 2 or 360 mm radiator X 1 or 280 mm radiator X 1

(E) IO ports: 1 x Audio / Microphone Combo Jack, 2 x USB 3.0, 1 x USB 3.2 Type C

(F) Removable Toolless SSD tray, Support 2.5" SSD x 3

(G) Removable HDD cage, Support 3.5" HDD x 2 or 2.5" SSD x 2

(H) PSU tray, Support ATX PSU x 1



## Hardware list

零件部品一覧表 / Liste du matériel / Hardwareliste / Lista de hardware / ハードウェアリスト

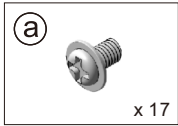

Screws  
for motherboard/  
2.5" SSD mounting

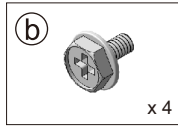

Screws  
for PSU mounting

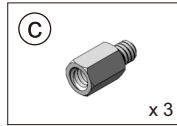

Stand-off bolt  
(spare parts)  
for M/B mount

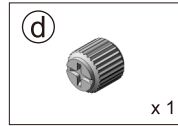

Tool  
for stand-off bolt

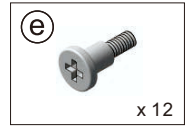

Screws  
for 2.5" SSD mount

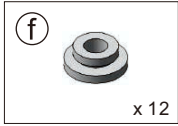

Anti-vibration rings  
for 2.5" SSD

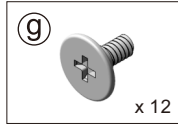

Screws  
for 3.5" HDD mount

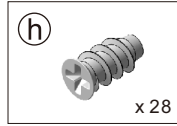

Screws  
for fan mounting

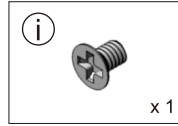

Screws  
for fixed PCIe slot

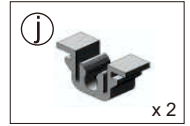

Female clips  
(spare parts)  
for side panel

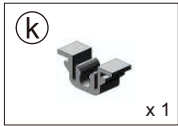

Female clips  
(spare parts)  
for side panel

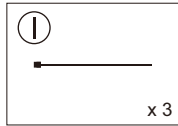

Cable ties  
for cable  
management

※ Exceeded quantity are spare parts.  
※ 多餘の零件數量是備品。  
※ Les pièces supplémentaires sont des pièces de rechange.  
※ Zusätzliche Teile können als Ersatzteile verwendet werden.  
※ Exceeded quantity are spare parts.  
※ ネジには予備が含まれていません。

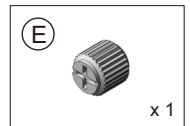
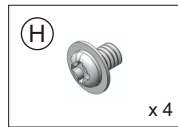
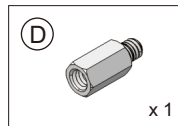
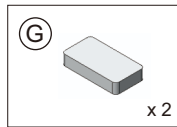
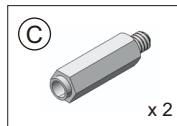
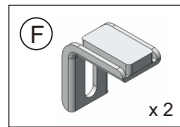
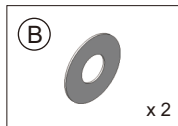
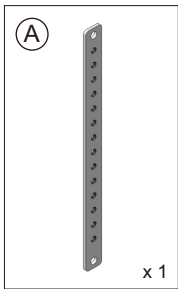

Tool  
for stand-off bolt

For graphic card anti-sag bracket kit installation/用於顯卡防下垂支架套件安裝/

Pour l'installation du kit de support anti-affaissement de la carte graphique

## PSU installation

電源供應器安裝 /

Installation du plateau du bloc d'alimentation /

PSU-Einsatz installieren /

Instalación de la fuente de alimentación /

電源のインストール

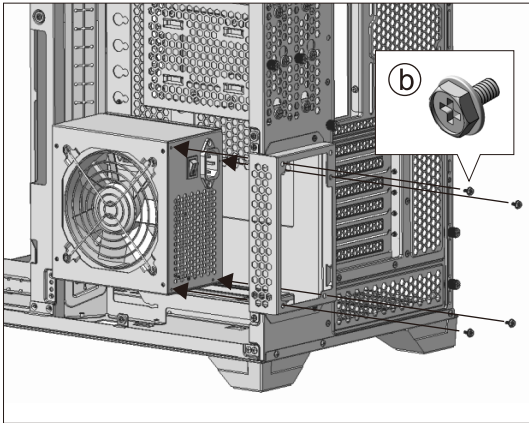

Way 1: Install Directly/使用方式一：直接安裝/  
Méthode 1: Installer directement

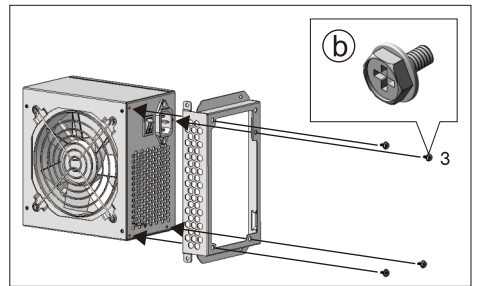
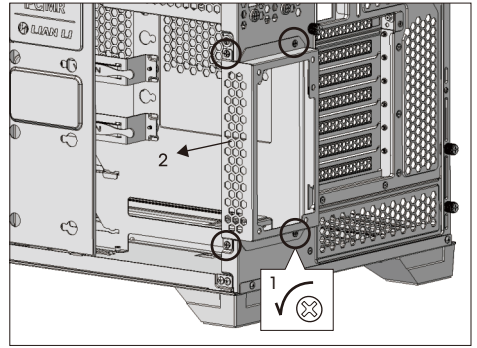

Way 2: Remove the bracket and install/使用方式二：拆下支架安裝/Voie 2: Retirez le support et installez

## I/O ports function

I/O port 功能說明/Installation du port I/O/I/O-Port installieren/Instalación de los puertos de I/O/I/Oポート機能

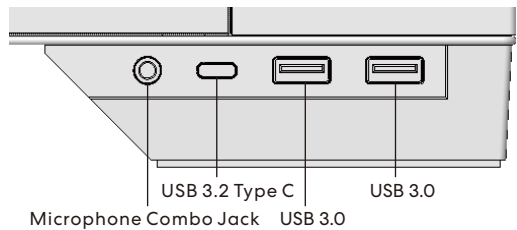
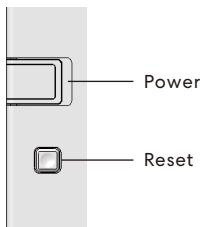

### POWER / RESET

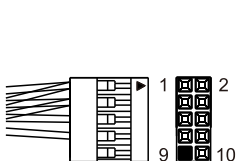

Definition	
1	Power LED+
2	Power LED-
3	Power SW+
4	Power SW-
5	Reset SW+
6	Reset SW-

### USB 3.0

Supports motherboard  
USB 3.0 20 Pin header

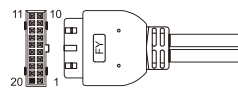

### USB 3.2 GEN.2

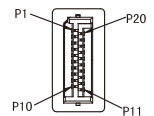

### HD AUDIO

Blue 10 7 Green  
Black purple 8 7 Key  
Yellow 6 5 Orange  
Gray 4 3 N.C.  
Red 2 1 GND+H.S. TUBE



## 2.5" SSD installation

2.5" SSD 安裝 / Installation de 2.5" SSD / 2.5" SSD-Installation / Instalación de 2.5" SSD / 2.5" SSD の取り付け

Way 1: Swing 180° to open / 使用方式一：翻轉180度 /

Méthode 1: Pivotez à 180° pour ouvrir

Way 2: Remove / 使用方式二：取下 /

Méthode 2: Retirer

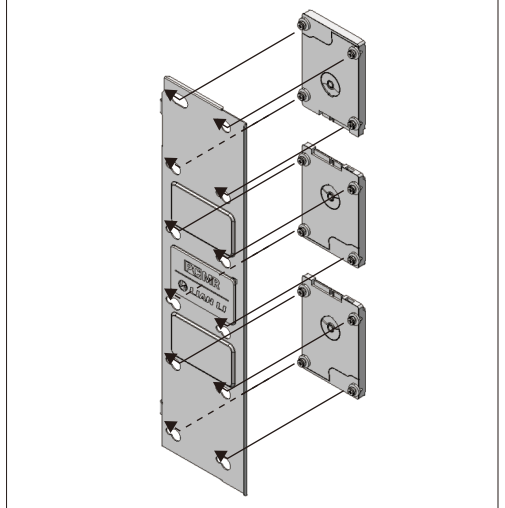
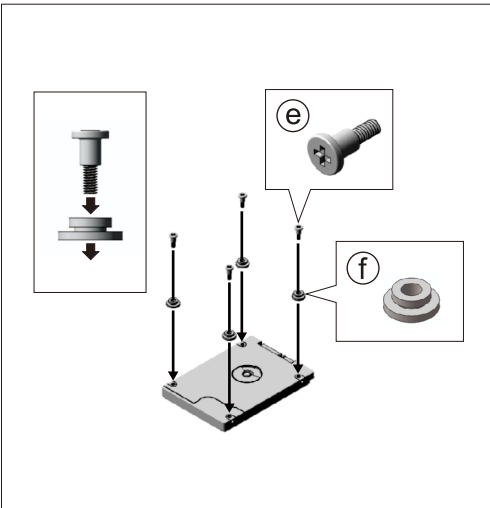
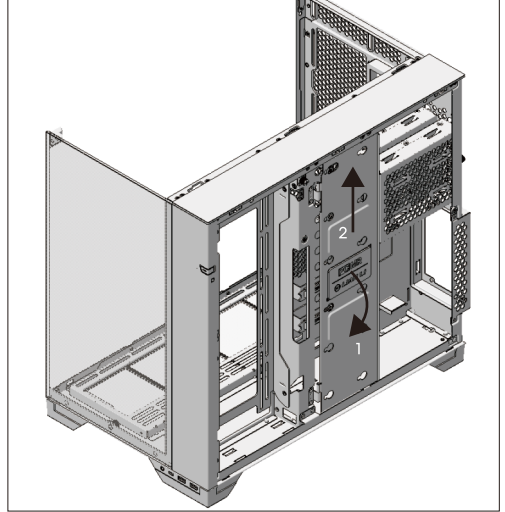
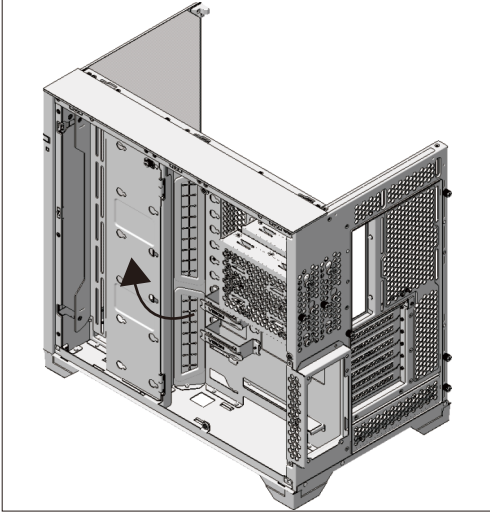

## 2.5" SSD, 3.5" HDD installation

2.5" SSD, 3.5" HDD 安裝 / Installation de 2.5" SSD, 3.5" HDD / 2.5" SSD, 3.5" HDD-Installation /  
Instalación de 2.5" SSD, 3.5" HDD / 2.5" SSD, 3.5" HDD の取り付け

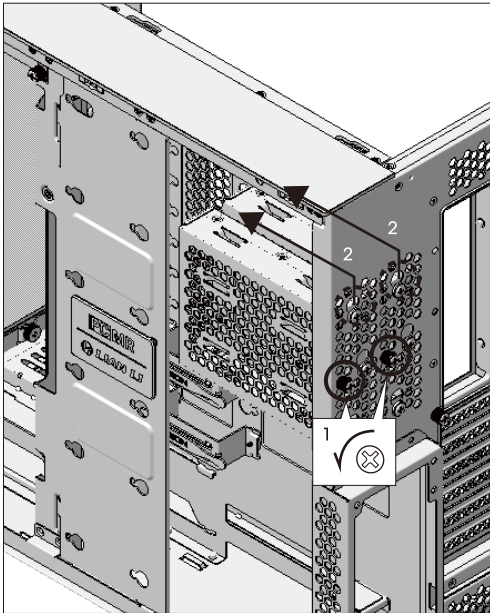

If space is needed, the hard drive cage can be removed/  
如有空間需求可將硬碟籠卸除/  
Si de l'espace est nécessaire, la cage du disque dur peut être retirée

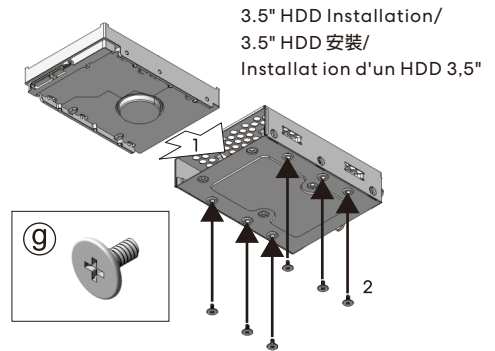
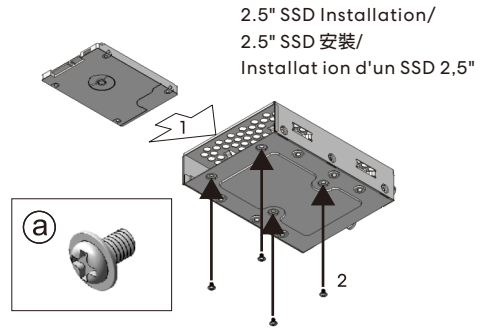

## Motherboard installation

主板安裝 / Installation de la carte mère / Mainboard-Installation / Instalación de la placa base /  
マザーボードの取り付け

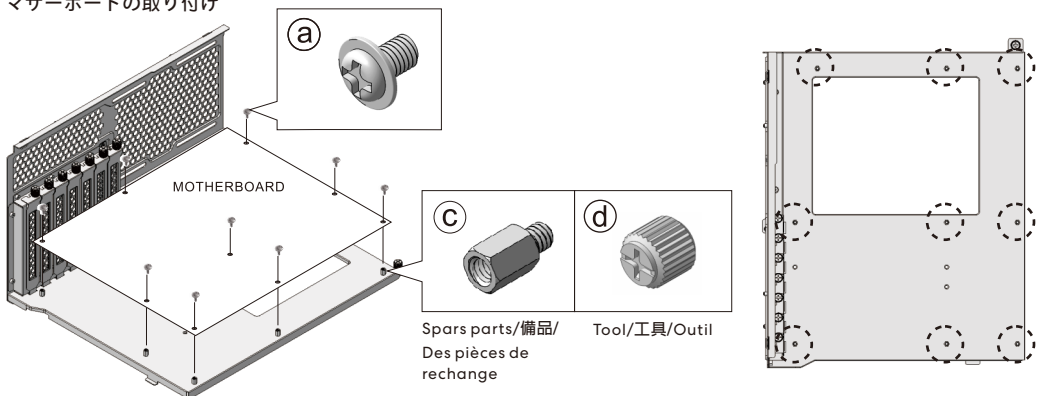

Please install the cooler backplate when removing the motherboard tray/  
請在MB板支架卸除時安裝散熱器背架/

Veuillez installer la plaque arrière du refroidisseur lorsque le plateau de la carte mère est retiré

## Remove the motherboard tray and back plate

卸除後板與遮片 / Retirez le panneau arrière et le masque / Entfernen Sie die Rückwand und die Maske /  
Retire el panel posterior y la máscara / バックパネルとマスクを取り外します

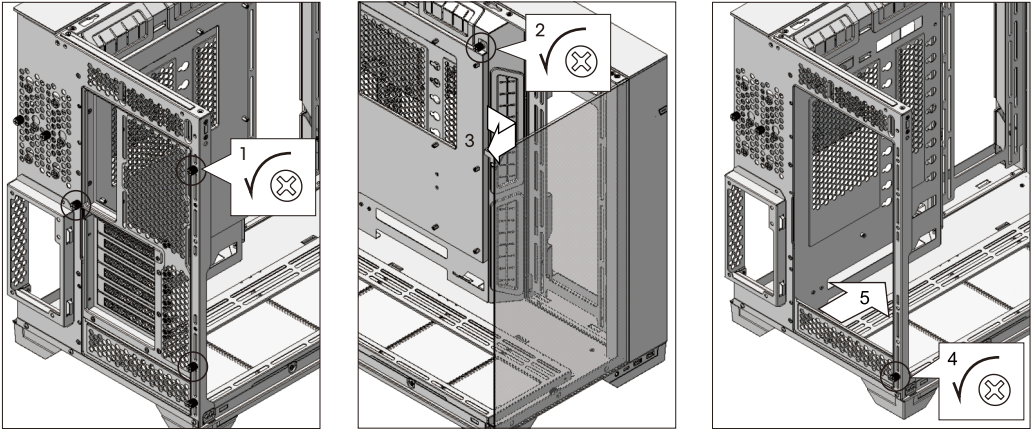

## Install the back plate and the motherboard tray

安裝後板與遮片 / Installez la plaque arrière et le masque / Installieren Sie die Rückplatte und die Maske /  
Instale la placa posterior y la máscara / バックプレートとマスクを取り付けます

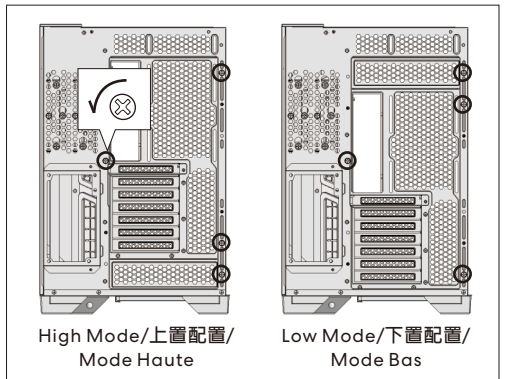
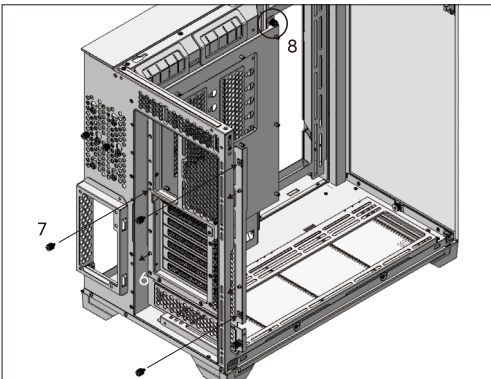
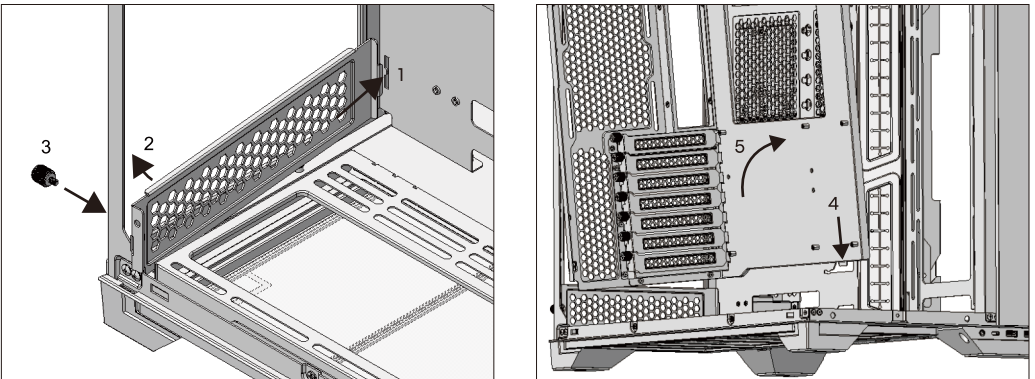

## First Slot Adjustment in Low Mode

下置模式第一槽調整方式/Premier Réglage de Fente en Mode Bas/Erste Einstellung im Niedrigmodus/  
Ajuste del primer espacio en modo bajo/低モードでの最初のスロット調整

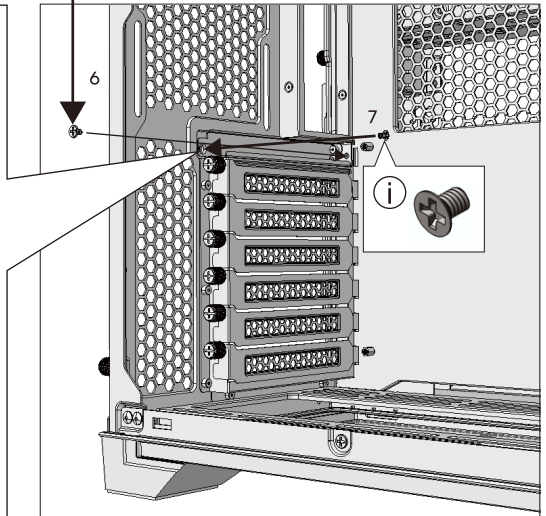
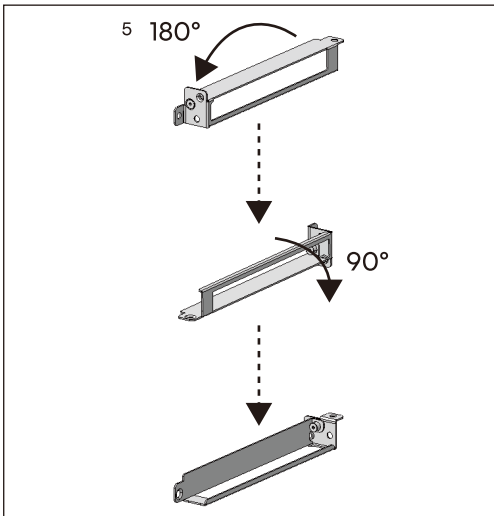
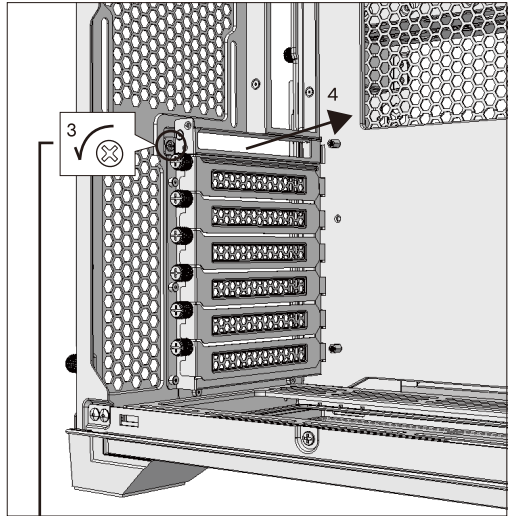
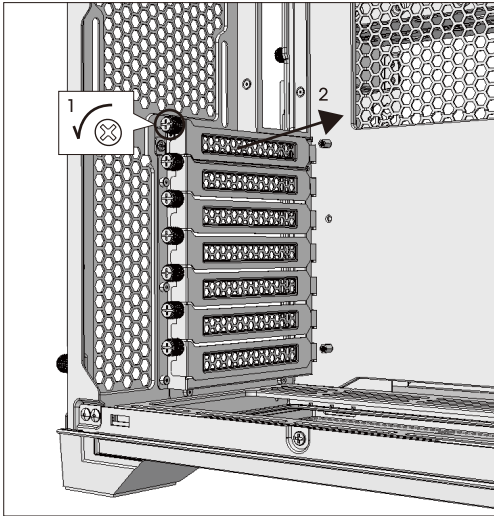

**!** Adjust to install a 240mm radiator at the rear side/完成此調整才可安裝240 mm散熱器/  
Ajustez pour installer un radiateur de 240 mm à l'arrière



## Radiator & cooling support

散热器&水冷排支援 / Radiateur et ventilation compatibilité / Kühler- und Kühlungsunterstützung  
/ Soporte de refrigeración y radiador / ラジエーターと冷却のサポート

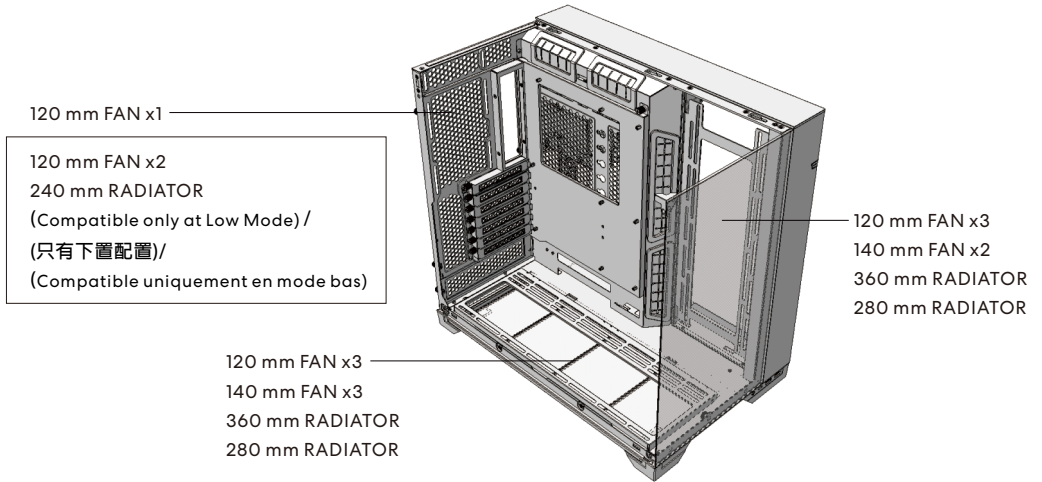

## Remove the bottom fan bracket

卸除下風扇支架 / Retirez le support inférieur du ventilateur / Entfernen Sie die untere Lüfterhalterung /  
Retire el soporte del ventilador inferior / 下部ファンブラケットを取り外します

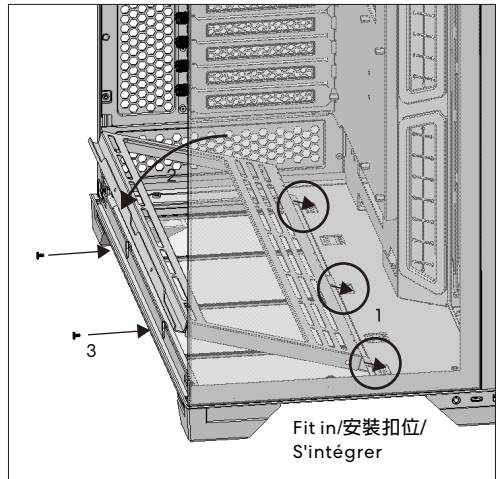
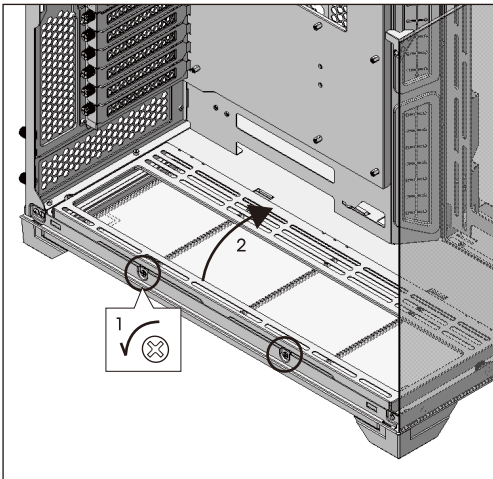



## Remove the side fan bracket

卸下側風扇支架 / Retirez le support du ventilateur latéral / Entfernen Sie die seitliche Lüfterhalterung  
/ Retire el soporte del ventilador lateral / サイドファンブラケットを取り外します

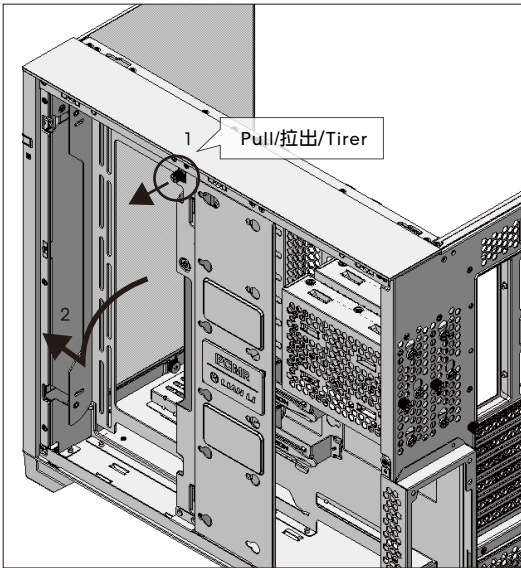

Two option scenario for installation:  
inner or outer/  
兩種安裝選擇：內部或外部/  
Scénario de deux options pour  
l'installation : intérieure ou extérieure

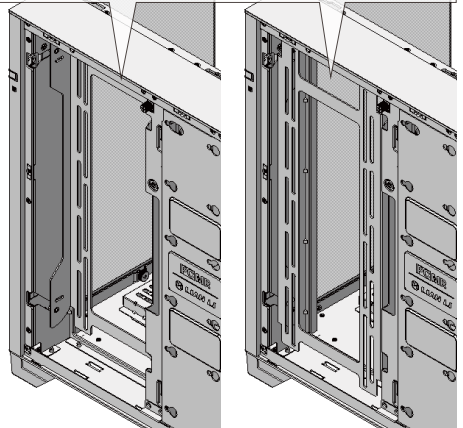

## Remove the dust filters

灰塵濾網拆卸 / Retirer les filtres à poussière / Entfernen Sie die Staubfilter / Retire los filtros de polvo /  
ダストフィルタを取り外す

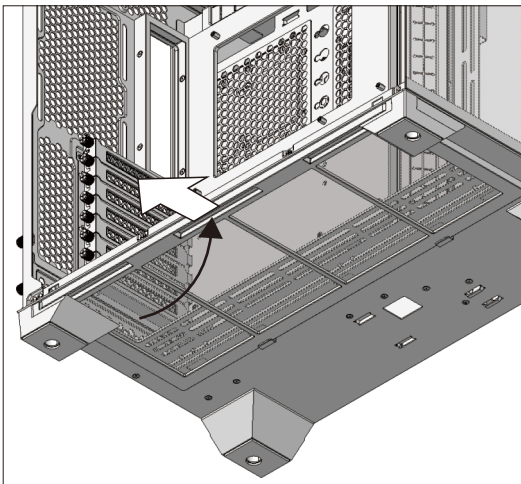

## Graphic card anti-sag bracket installation

顯卡支撐架安裝 / Installation du support anti-affaissement de la carte graphique /

Installation der Anti-Sag-Halterung für die Grafikkarte / Instalación del soporte antideslizamiento de la tarjeta gráfica / グラフィックカードのたるみ防止ブラケットの取り付け

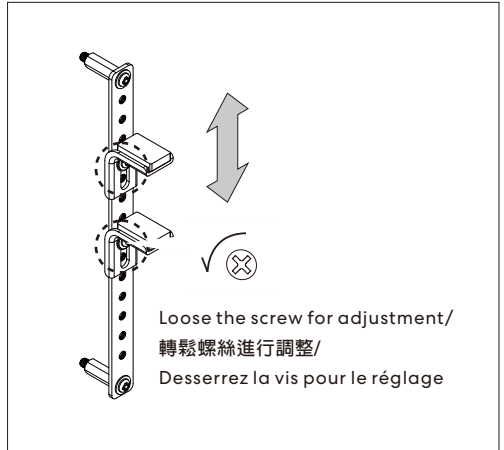
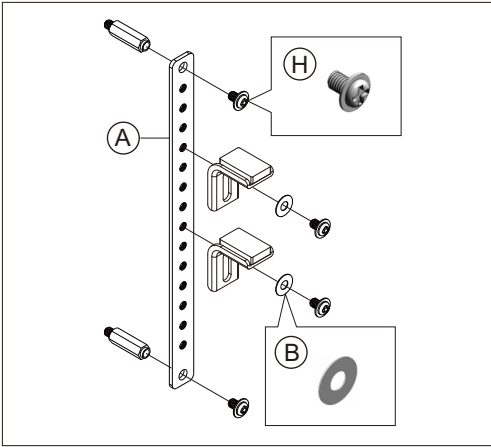

Installed on ATX motherboard / 安裝於ATX主板 /  
Installé sur carte mère ATX

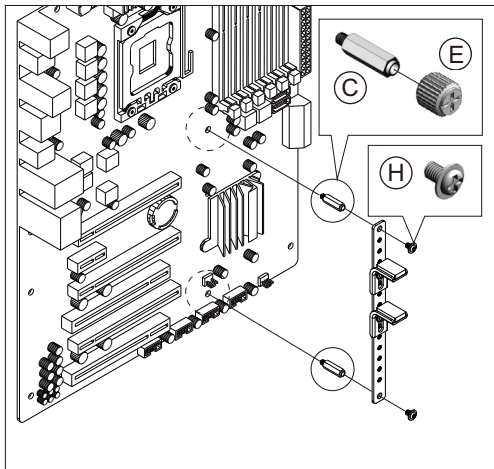

Installed on M-ATX motherboard / 安裝於M-ATX主板 /  
Installé sur carte mère M-ATX

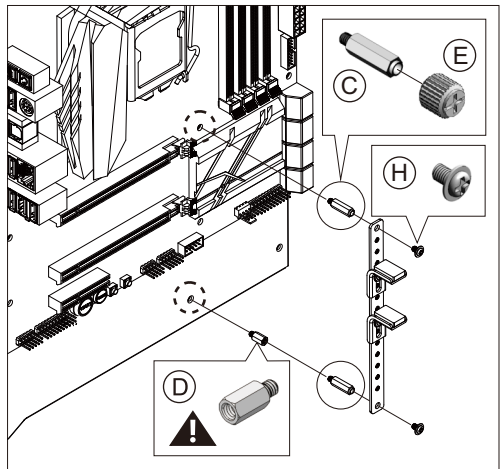

## Cable management

線材整理 / Gestion des câbles / Kabelmanagement /  
Mantenimiento de cable / ケーブル管理

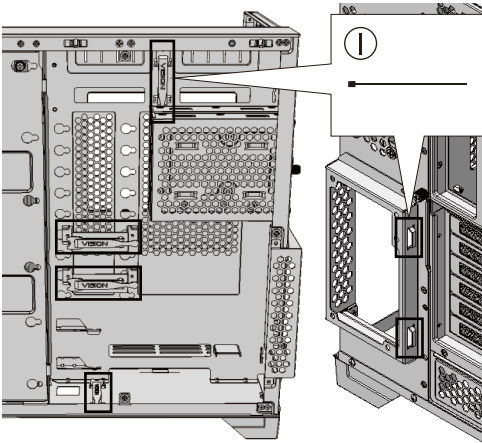

## Cable holder installation

整線扣安裝方式 / Installation complète de la boucle du  
câble / Installation der gesamten Kabelschnalle /  
Instalación de hebilla de cable completo /  
全ラインバックルの取り付け

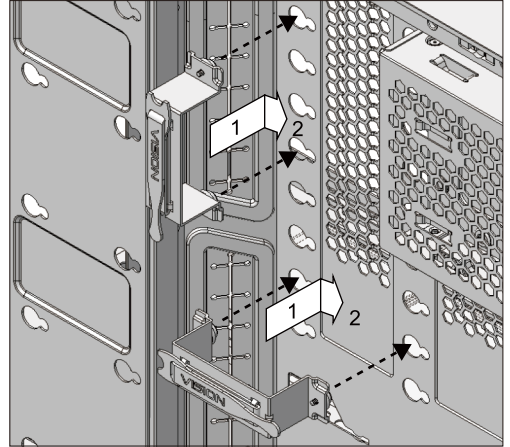

## Use of cable holder

整線扣整線說明 / Description complète de la ligne complète de la boucle du câble / Ganze Beschreibung der  
gesamten Kabelschnalle / Descripción de toda la línea de hebilla de cable completo / バックル全体 ライン全体

Keep the big cables in the cable  
holders/

先將粗線整在金屬框架內/  
Gardez les gros câbles dans les  
porte-câbles

Hold the small cables with the  
velcro straps/

再將細線使用魔鬼氈整好/  
Maintenez les petits câbles avec  
les bandes velcro

Remove the velcro strap to place  
a controller/

亦可拆下魔鬼氈作為控制器黏貼處/  
Retirez la bande velcro pour  
placer un contrôleur

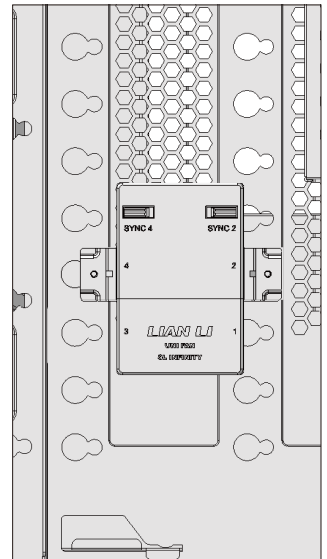
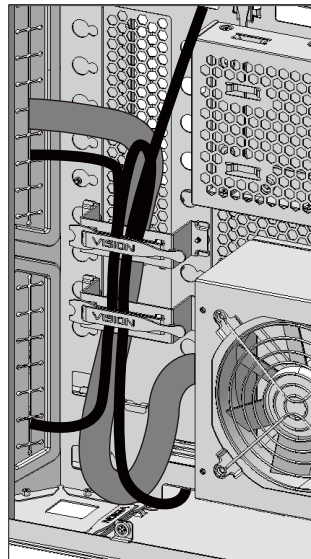
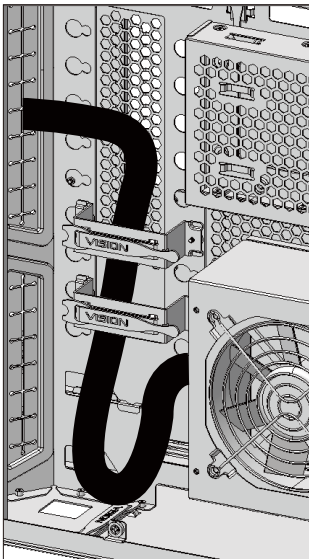

## Hardware clearance

硬體擴充支援 / Liquidation du matériel / Hardware-Freigabe / Liquidación de hardware / ハードウェアクリアランス

CPU height clearance/CPU高度間隙/  
Dégagement en hauteur du processeur

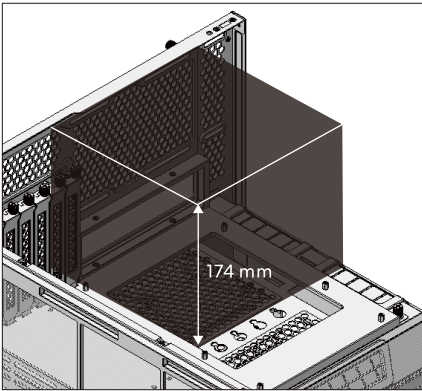

PSU clearance/PSU間隙/  
Dégagement du bloc d'alimentation

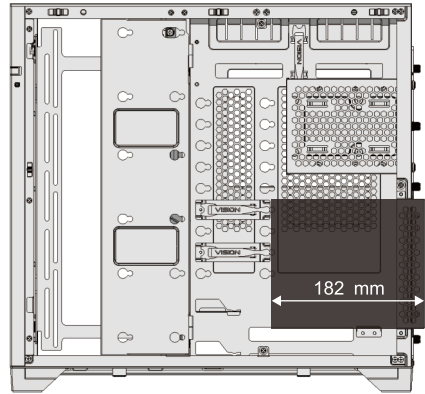

GPU clearance/GPU間隙/Dégagement GPU

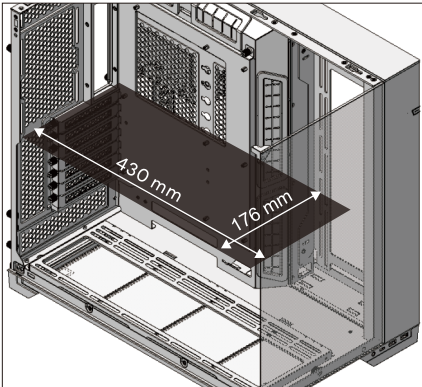

PSU clearance/PSU間隙/  
Dégagement du bloc d'alimentation

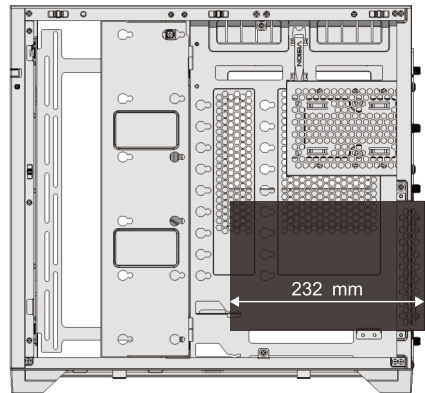

Radiator and fan combo height clearance/  
散熱器和風扇組合高度間隙/Dégagement combiné en  
hauteur du radiateur et du ventilateur

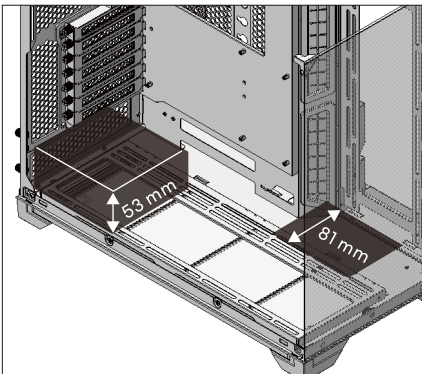



Ovaj dokument je originalno proizveden i objavljen od strane proizvođača, brenda Lian Li, i preuzet je sa njihove zvanične stranice. S obzirom na ovu činjenicu, Tehnoteka ističe da ne preuzima odgovornost za tačnost, celovitost ili pouzdanost informacija, podataka, mišljenja, saveta ili izjava sadržanih u ovom dokumentu.

Napominjemo da Tehnoteka nema ovlašćenje da izvrši bilo kakve izmene ili dopune na ovom dokumentu, stoga nismo odgovorni za eventualne greške, propuste ili netačnosti koje se mogu naći unutar njega. Tehnoteka ne odgovara za štetu nanесenu korisnicima pri upotrebi netačnih podataka. Ukoliko imate dodatna pitanja o proizvodu, ljubazno vas molimo da kontaktirate direktno proizvođača kako biste dobili sve detaljne informacije.

Za najnovije informacije o ceni, dostupnim akcijama i tehničkim karakteristikama proizvoda koji se pominje u ovom dokumentu, molimo posetite našu stranicu klikom na sledeći link:

<https://tehnoteka.rs/p/lian-li-kuciste-o11-vision-belo-akcija-cena/>