

Uputstvo za upotrebu

RUSSELL HOBBS multicooker 21850-56



Tehnoteka je online destinacija za upoređivanje cena i karakteristika bele tehnike, potrošačke elektronike i IT uređaja kod trgovinskih lanaca i internet prodavnica u Srbiji. Naša stranica vam omogućava da istražite najnovije informacije, detaljne karakteristike i konkurentne cene proizvoda.

Posetite nas i uživajte u ekskluzivnom iskustvu pametne kupovine klikom na link:

<https://tehnoteka.rs/p/russell-hobbs-multicooker-21850-56-akcija-cena/>



Russell Hobbs



GB

DE

FR

NL

IT

ES

PT

DK

SE

NO

FI

RU

CZ

SK

PL

HR

SI

GR

HU

TR

RO

BG

AE

21850-56

 www.russellhobbs.com

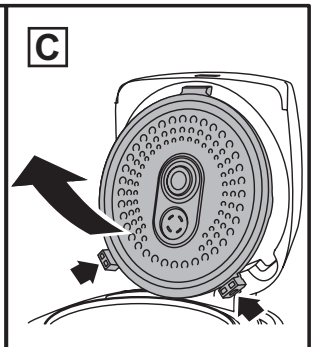
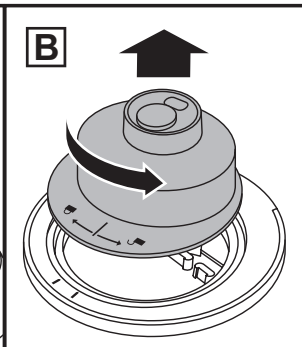
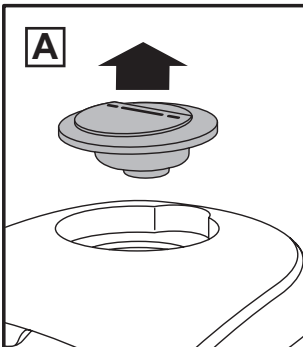
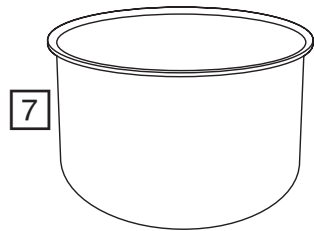
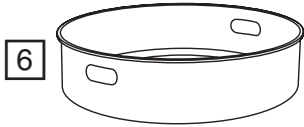
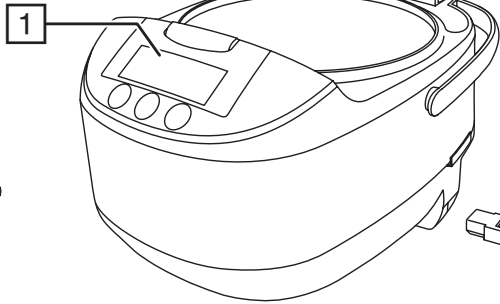
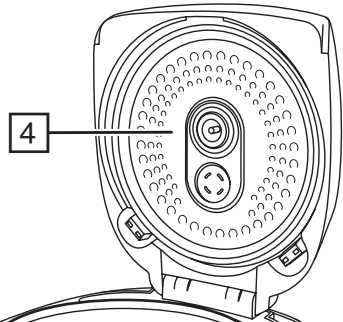
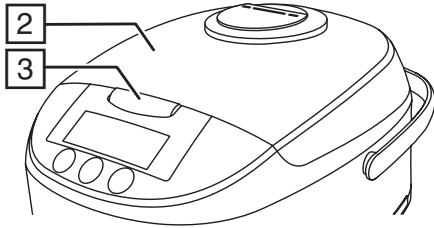

Read the instructions, keep them safe, pass them on if you pass the appliance on. Remove all packaging before use.





IMPORTANT SAFEGUARDS

Follow basic safety precautions, including:

This appliance can be used by children aged 8 years and above and persons with reduced physical, sensory or mental capabilities or lack of experience and knowledge if they have been supervised/instructed and understand the hazards involved. Children shall not play with the appliance. Cleaning and user maintenance shall not be done by children unless they are older than 8 and supervised. Keep the appliance and cable out of reach of children under 8 years.

If the connector or cable are damaged, they must be replaced by a special assembly available from the manufacturer or its service agent.

 Do not use this appliance near bathtubs, showers, basins or other vessels containing water.

 Misuse of the appliance may cause injury.

 The surfaces of the appliance will get hot. Residual heat will keep the surfaces hot after use.

- Don't put frozen meat or poultry in the appliance – defrost fully before use.
- Cook meat, poultry, and derivatives (mince, burgers, etc.) till the juices run clear. Cook fish till the flesh is opaque throughout.
- Don't try to cook anything in the body of the cooker – cook only in the removable bowl.
- Don't fill above **max**.
- Don't cover the appliance or put anything on top of it.
- Remove the plug from the power socket, then remove the connector from the power inlet on the appliance.
- Unplug the appliance when not in use.
- Don't use accessories or attachments other than those we supply.
- Don't use the appliance for any purpose other than those described in these instructions.
- Don't use the appliance if it's damaged or malfunctions.

HOUSEHOLD USE ONLY

PARTS

- | | |
|------------------|------------------|
| 1. Control panel | 5. Measuring cup |
| 2. Lid | 6. Basket |
| 3. Lid Lock | 7. Bowl |
| 4. Inner Lid | 8. Connector |



PREPARATION

1. Sit the appliance on a stable, level, heat-resistant surface.
2. Don't use the appliance near or below curtains, shelves, cupboards, or anything else likely to be damaged by the escaping steam.
3. Have oven gloves (or a cloth) to hand, and a heat-resistant mat or dinner plate to put the bowl on



after cooking.

4. Put the bowl inside the cooker.
 5. Give the bowl quarter of a turn each way, to ensure the bottom of the bowl makes good contact with the element.
-



RICE

1. Use the measuring cup to put the rice into the bowl.
 2. Don't use more than 10 cups of rice.
 3. Use the scale on the left, inside the bowl, which is marked from 2 to 10.
 4. Fill the bowl with water up to the number corresponding to the number of cups of rice used.
 5. Close the lid.
 6. Press the  button. The button will light up.
 7. The outer segments of the display will blink while the food heats up.
 8. The display will then show the remaining cooking time (13 minutes), and count down.
 9. At the end of the cooking time, the appliance will go into "keep warm" mode.
 10. The  light will come on.
 11. Open the lid.
 12. Lift out the bowl and set it down on a heat-resistant mat or dinner plate.
 13. Press the  button.
 14. Use the spatula to turn and mix the rice, to let all the steam escape.
 15. Sometimes the layer of rice in contact with the bowl will form a crust.
 16. If you don't want it you can remove it with the spatula, after you've served the rice.
-

SLOW COOKING





1. Brown meat and vegetables (see "BROWN/SAUTE/SOFTEN/BOIL").
 2. Boil the cooking liquid (see "BROWN/SAUTE/SOFTEN/BOIL").
 3. Put the solid ingredients into the bowl, then add the cooking liquid.
 4. Close the lid.
 5. Press the  button. The button will light up.
 6. The display will show 8 hours, and count down.
 7. At the end of the cooking time, the appliance will go into "keep warm" mode.
 8. The  light will come on.
 9. Press the  button. Open the lid. Remove the food.
-

STEWING





1. Brown meat and vegetables (see "BROWN/SAUTE/SOFTEN/BOIL").
 2. Boil the cooking liquid (see "BROWN/SAUTE/SOFTEN/BOIL").
 3. Put the solid ingredients into the bowl, then add the cooking liquid.
 4. Close the lid.
 5. Press the  button. The button will come on.
 6. The display will show 1 hour, and count down.
 7. At the end of the cooking time, the appliance will go into "keep warm" mode.
 8. The  light will come on.
 9. Press the  button. Open the lid. Remove the food.
-

MEAT

1. Rub the food all over with cooking oil.
2. Rub any seasonings over the surface of the food.
3. Put a tablespoon of cooking oil in the bowl.
4. Put the food in the bowl.
5. Close the lid.

6. Time depends on the size of the food.
7. Don't cook more than about 500g of food at a time.
8. We suggest cooking times of 10 minutes + 10 minutes per 100g of weight for beef.
9. Don't cook pork or poultry for less than 5, 10, 15, 20, 25, 30 minutes.
10. Use the  button to select  in the menu.
11. Choose the cooking time. The default time is 20 minutes.
12. You can only use the h and min buttons while the display time is blinking.
13. Use the min button to move the display through the options (10, 15, 20, 25, 5, 10, 15, 20, 25, 30, 35, 40, 45, 50, and 55).
14. If you want to cook for 1 hour, press the h button.
15. To undo the 1 hour setting, press the h button again, while the display time is blinking.
 - If you do nothing for 2 minutes, the appliance will revert to standby mode.
16. When you have set the time, press .
17. The display will count down.
18. At the end of the cooking time, the appliance will go into "keep warm" mode.
19. The  light will come on.
20. Press the  button. Open the lid. Remove the food.

SOUP

1. Brown meat and vegetables (see "BROWN/SAUTE/SOFTEN/BOIL").
2. Put the solid ingredients into the bowl, then add the cooking liquid.
3. Close the lid.
4. Use the  button to select  in the menu.
5. Choose the cooking time. The default time is 1 hour.
6. You can only use the h and min buttons while the display time is blinking.
7. Use the min button to move the display through the options (10, 15, 20, 25, 5, 10, 15, 20, 25, 30, 35, 40, 45, 50, and 55).
8. Use the h button to move the display through the options (1, 2, 3, 4, and 5).
9. To undo the 5 hour setting, press the h button again, while the display time is blinking.
 - If you do nothing for 2 minutes, the appliance will revert to standby mode.
10. You have the option of using the timer with this program (see TIMER).
11. Press the .
12. The display will count down.
13. At the end of the cooking time, the appliance will go into "keep warm" mode.
14. The  light will come on.
15. Press the  button. Open the lid. Remove the food.

YOGHURT

Yoghurt culture

You may use 5, 10, 15, 20, 25, 30ml (2 tablespoons) of:

- Unflavoured live yoghurt – it must be fresh (look for a long expiry date). Different brands will give different results.





Yoghurt you made previously.

- The bacteria weakens over time, so you can only do this 10 times before using another new culture.
- Freeze-dried yoghurt culture from a pharmacy or health food shop
- If the instructions on the culture package differ from this guide, follow the instructions on the package.





Milk

- You will need 1 litre of milk.
- Whole milk gives thicker yoghurt than low fat milk.
- To make it even thicker, you may add up to 8 tablespoons of powdered milk to the liquid milk.
- You may also use reconstituted powdered milk, or tinned evaporated milk.

Making yoghurt





1. You need to kill the bacteria in the milk, to prevent them competing with the bacteria in the yoghurt culture.
2. While you are heating the milk, let the yoghurt culture get to room temperature.
3. Open the lid.
4. Use the STEAMING (BROWN/SAUTE/SOFTEN/BOIL) program to heat the milk to just below boiling.
5. Let the milk heat till it begins to bubble at the edges.
6. Let the milk cool to between 37°C and 45°C.
7. Stir the yoghurt culture into the milk.
8. They must be thoroughly mixed, or the yoghurt will be lumpy.
9. Close the lid.
10. Use the  button to select  in the menu.
11. Choose the cooking time. The default time is 8 hours.
12. You can only use the h and min buttons while the display time is blinking.
13. Use the min button to move the display through the options (10, 15, 20, 25, 5, 10, 15, 20, 25, 30, 35, 40, 45, 50, and 55).
14. Use the h button to move the display through the options (6, 7, 8, 9, and 10).
15. To undo the 10 hour setting, press the h button again, while the display time is blinking.
- If you do nothing for 2 minutes, the appliance will revert to standby mode.
16. You have the option of using the timer with this program (see TIMER).
17. Press the  button.
18. The display will count down.
19. At the end of the cooking time, the appliance will go into standby mode.
20. It will not keep the yogurt warm.
21. Press the  button. Open the lid. Remove the food.

BREAD



1. Defrost frozen dough thoroughly before use.
2. Don't cook more than about 500g of food at a time.
3. Wipe the bowl with cooking oil.
4. Put the dough into the bowl.
5. Close the lid.
6. Use the  button to select  in the menu.
7. Choose the cooking time. The default time is 3 hours.
8. You can only use the h and min buttons while the display time is blinking.
9. Use the min button to move the display through the options (10, 15, 20, 25, 5, 10, 15, 20, 25, 30, 35, 40, 45, 50, and 55).
10. Use the h button to move the display through the options (1, 2, 3, 4, 5, and 6).
11. To undo the 6 hour setting, press the h button again, while the display time is blinking.
- If you do nothing for 2 minutes, the appliance will revert to standby mode.
12. You have the option of using the timer with this program (see TIMER).
13. Press the  button.
14. The display will count down.
15. At the end of the cooking time, the appliance will go into "keep warm" mode.
16. The  light will come on.
17. Press the  button. Open the lid. Remove the food.

FISH



1. Rub the food all over with cooking oil.
2. Rub any seasonings over the surface of the food.
3. Put a tablespoon of cooking oil in the bowl.
4. Put the food in the bowl.

5. Close the lid.
6. Time depends on the size of the food.
7. Don't cook more than about 500g of food at a time.
8. We suggest cooking times of 10 minutes per 100g of weight.
9. Use the  button to select  in the menu.
10. Choose the cooking time. The default time is 20 minutes.
11. You can only use the h and min buttons while the display time is blinking.
12. Use the min button to move the display through the options (10, 15, 20, 25, 5, 10, 15, 20, 25, 30, 35, 40, 45, 50, and 55).
13. If you want to cook for 1 hour, press the h button.
14. To undo the 1 hour setting, press the h button again, while the display time is blinking.
 - If you do nothing for 2 minutes, the appliance will revert to standby mode.
15. When you have set the time, press .
16. The display will count down.
17. At the end of the cooking time, the appliance will go into "keep warm" mode.
18. The  light will come on.
19. It's best to remove the food as soon as it has cooked, to prevent it drying out.
20. Press the  button. Open the lid. Remove the food.

STEAMING

1. Fill the bowl with cold water up to the 6 mark.
2. Put the basket on top of the bowl and put the food into the basket.
3. For uniform cooking, cut all pieces of food to roughly the same size.
4. For peas, or anything that'll break up or drop into the water, make a parcel with aluminium foil.
5. Take care when removing the parcel – wear oven gloves and use plastic tongs/spoons.
6. Close the lid.
7. Use the  button to select  in the menu.
8. Choose the cooking time. The default time is 30 minutes.
 - These should cook within the default time:

Food (fresh)	Quantity
Green beans	200g
Brussels sprouts	200g
Carrots (sliced)	200g
Potatoes (quartered)	400g
Broccoli	200g
Cabbage	Quarter
Corn cobs	2

9. You can only use the h and min buttons while the display time is blinking.
10. Use the min button to move the display through the options (5, 10, 15, 20, 25, 30, 35, 40, 45, 50, and 55).
11. Use the h button to move the display through the options (1, and 2).
12. To undo the 2 hour setting, press the h button again, while the display time is blinking.
 - If you do nothing for 2 minutes, the appliance will revert to standby mode.
13. You have the option of using the timer with this program (see TIMER).
14. Press the .
15. The display will count down.
16. At the end of the cooking time, the appliance will go into "keep warm" mode.
17. The  light will come on.

18. It's best to remove the food as soon as it has cooked, to prevent it going soggy.
19. Press the  button. Open the lid. Remove the food.

BROWN/SAUTE/SOFTEN/BOIL

- You may use the STEAMING  program at its default setting, with the lid open, as a high temperature pan for 5, 10, 15, 20, 25, 30 minutes, prior to cooking with another program.
- Use it with a little oil to brown meat and vegetables, to sauté, to soften onions, celery, leeks, etc.
- Use it with water or stock to pre-heat cooking liquids.
- When you switch to the main program, the appliance is warmed up, and some or all of your ingredients will already be in the bowl.
- You don't then have to wash the pan you would have used during preparation.





PORRIDGE/RISOTTO

Use the measuring cup to put the grain (rice, oats, barley, etc.) into the bowl.

Porridge

- Use the scale on the right, inside the bowl, which is marked from ½ to 1½.
- Don't fill above **max**.



Congee



- Use the scale on the centre, inside the bowl, which is marked from 1 to 3.
 - Don't fill above **max**.
1. Fill the bowl with water up to the number corresponding to the number of cups of grain.
 2. Close the lid.
 3. Use the  button to select  in the menu.
 4. Choose the cooking time. The default time is 1 hour.
 5. You can only use the h and min buttons while the display time is blinking.
 6. Use the min button to move the display through the options (5, 10, 15, 20, 25, 30, 35, 40, 45, 50, and 55).
 7. Use the h button to move the display through the options (1, 2, 3, and 4).
 8. To undo the 4 hour setting, press the h button again, while the display time is blinking.
 - If you do nothing for 2 minutes, the appliance will revert to standby mode.
 9. You have the option of using the timer with this program (see TIMER).
 10. Press the  button.
 11. The display will count down.
 12. At the end of the cooking time, the appliance will go into "keep warm" mode.
 13. The  light will come on.
 14. Press the  button. Open the lid. Remove the food.

Risotto



Follow the recipe shown later in this booklet.

CAKE









1. Defrost frozen dough thoroughly before use.
2. Don't fill the bowl more than about half full.
3. Wipe the bowl with cooking oil.
4. Put the dough into the bowl.
5. Close the lid.
6. Use the  button to select  in the menu.
7. Choose the cooking time. The default time is 40 minutes.
8. The default time is 40 minutes.
9. You can only use the h and min buttons while the display time is blinking.
10. Use the min button to move the display through the options (5, 10, 15, 20, 25, 30, 35, 40, 45, 50, and 55).
11. Use the h button to move the display through the options (1, and 2).
- To undo the 2 hour setting, press the h button again, while the display time is blinking.
- If you do nothing for 2 minutes, the appliance will revert to standby mode.

12. When you have set the time, press .
13. The display will count down.
14. At the end of the cooking time, the appliance will go into “keep warm” mode.
15. The  light will come on.
16. It’s best to remove the food as soon as it has cooked, to prevent it going soggy.
17. Press the  button. Open the lid. Remove the food.

KEEP WARM

- If you want to use the keep warm feature after a program that doesn’t support it, then, when the only thing showing on the display is the blinking  light, press .
- Press  to exit this feature.

THE TIMER

- You may use the delay timer with the soup , yoghurt , bread , steam , and porridge  programs.
- Do this immediately after setting the cooking time, and before pressing start :
 1. Press the  button. The  light will come on.
 2. Decide when you want the food to be ready.
 3. For example, if it is 2.00 now, and you want it to be ready at 9.00, you must set the time to 7 hours.
 4. Use the **h** and **min** buttons to set the correct hour and minute.
 5. Press the  button.

CARE AND MAINTENANCE







1. Unplug the appliance and let it cool.
2. Remove the plug from the power socket, then remove the connector from the power inlet on the appliance.
3. With the lid closed, grip the top of the filter and lever it out of the lid. (FIG A).
4. Turn it over, to expose the markings on the front edge.
5. Hold the filter lid fast, and turn the rest of the filter towards the open padlock  (FIG B).
6. Press on the tabs at the bottom of the inner lid, and pull it off the appliance. (FIG C).
7. Hand wash the removable parts.
8. Wipe all surfaces with a clean damp cloth.
9. Don’t put any part of the appliance in a dishwasher.
10. Reassemble the filter, and replace it in the lid.
11. Replace the inner lid in the lid.









RECYCLING







To avoid environmental and health problems due to hazardous substances, appliances and rechargeable and non-rechargeable batteries marked with one of these symbols must not be disposed of with unsorted municipal waste. Always dispose of electrical and electronic products and, where applicable, rechargeable and non-rechargeable batteries, at an appropriate official recycling/collection point.

RECIPES

	teaspoon (15ml)
	teaspoon (5ml)
g	grams
ml	millilitres
	measuring cup
	stick/rib (celery)
	handful
	egg, medium (53-63 g)





	pinch
	bunch
	sprig
	clove(s)
	tin/can
	jar
	sachet (7g)
	egg, large (63-73 g)

VEGETABLE AND COUSCOUS CHILLI

1	red onion, chopped
1	large onion, chopped
2 	garlic, peeled and chopped
1	red pepper, deseeded and chopped
1	yellow pepper, deseeded and chopped
1	orange pepper, deseeded and chopped
1 	ground coriander
1 	tomato purée
850 ml	vegetable stock
2 	hot tomato sauce
120-140 ml	couscous

to serve:

- grated cheese
- sour cream
- small bunch coriander, chopped





Open the lid. Add the oil. Select  on the menu, and press . Add the onion and garlic. Cook till the onions soften. Drain the beans and add them. Reserve the couscous. Add the remaining ingredients. Press  twice to stop the program. Close the lid. Select . Add the couscous 30 minutes before cooking ends. If cooking has already finished, select  on the menu and cook for about 20 minutes more. Serve in a bowl with a handful of cheese, a drizzle of sour cream, and a sprinkle of fresh coriander. For a classic vegetarian chilli, omit the couscous.

HOME-MADE YOGHURT

1200 ml milk

Flavour option

50 g frozen mixed summer berries

Open the lid. Add the milk. Select  on the menu, and press . Let the milk heat till it begins to bubble at the edges. Press  twice to stop the program. Let the milk cool to between 37°C and 45°C. Stir the yoghurt into the milk. They must be thoroughly mixed, or the yoghurt will be lumpy. Close the lid. Select  on the menu, and press . Wait till the program ends. Put the yoghurt in the fridge to cool completely. Heat the berries gently in a pan. Add the honey. When the berries begin to collapse, remove from the heat, allow to cool, then mix with the yoghurt. If you want to store your yoghurt you must sterilize the jars you are going to use. Heat them in an oven at 100°C for 10 minutes. The yoghurt will keep for up to 2 of weeks in the fridge.

SLOW COOK

1 	olive oil
1 	butter beans
1 	cannellini beans
1 	green jalapenos
1 	kidney beans
1 	chopped tomatoes
2 	ground cumin
1 	sugar
2 	chilli powder
2 	dried oregano

YOGHURT







100 ml yoghurt



1  honey





FIERY NY BEEF CHILLI

STEW 





- 450 g braising beef
- 3  garlic, peeled and chopped
- 2  ground cumin
- 1  cayenne pepper
- 1  smoked paprika/chipotle powder
- 1 green pepper
- 1  salt
- 1  basil leaves, roughly chopped





- 1  olive oil
- 2 onions, chopped
- 2  chilli powder
- 2  tomato sauce
- 2  tomatoes
- 1  bayleaf
- 1  black pepper
- 1  kidney beans



Open the lid. Add the oil. Select  on the menu, and press . Chop the beef, tomatoes and pepper into bite sized chunks. Brown the meat, then remove it. Add the onions, garlic and all the herbs. Cook till the onions soften. Add the meat. Reserve the beans. Add the remaining ingredients. Press  twice to stop the program. Close the lid. Select . Add the beans 30 minutes before cooking ends. If the meat is still a little tough at the end of the program, add a cup of water, and run the meat program for an additional 30 minutes.

MOROCCAN FISH TAGINE

FISH 



- 2  garlic, peeled and chopped
- 1 red pepper, deseeded and chopped
- 2 chopped tomatoes
- 1  ground ginger
- 1 cinnamon stick
- 120 ml white wine
- 120 ml fish stock
- 675 g fish (cod/haddock/salmon)
- 1 small bunch coriander, chopped



- 1 onion, chopped
- 2  celery, chopped
- 1  ground cumin
- 1  turmeric
- 1  harissa paste
- 1  tomato purée
- 1 lemon
- 1  green olives





Reserve the coriander. Open the lid. Add the remaining ingredients. Close the lid. Select  on the menu, and press . Cook till the fish becomes flaky (40-60 minutes). Press  twice to stop the program. Add the coriander. Adjust the seasoning and serve. This would be great with couscous.

SPLIT PEA AND HAM HOCK SOUP

SLOW COOK 



- 1150 ml chicken stock
- 225 g split peas
- 1  celery, chopped
- 1  thyme, finely chopped
- 1 ham hock



- 1 onion, finely chopped
- 1 carrot, chopped
- 2  garlic (crushed)
- 1  bayleaf
- black pepper



Open the lid. Add the stock. Select  on the menu, and press . Bring to the boil, stirring. Simmer for 10 minutes. Add the remaining ingredients. Press  twice to stop the program. Close the lid. Select . Wait till the program ends. Remove the ham hock. Discard the skin and bones. Dice the meat. Discard the bayleaf. Mash the split peas with the back of a wooden spoon. Add the meat. Adjust the seasoning, and serve. Heaven in a bowl!

SALMON WITH A SPICY RUB

FISH 

- 2 salmon fillets (with skin)
- 1  paprika
- 1  ground cumin
- 1  soft brown sugar



- 1  olive oil
- 1  chilli powder
- 1  salt and pepper
- 1 lemon

Mix the paprika, chilli powder, cumin, sugar, salt and pepper. Sprinkle over the salmon fillets. Open the lid. Add the oil. Select  on the menu, and press . Wait a couple of minutes to let the oil heat. Add the fillets, skin down. Close the lid. This is a great combination of steaming and pieces of fish but you get a crispy skin. Serve with a wedge of lemon. A great light meal.

CHOCOLATE BROWNIE CAKE



CAKE

170 g unsalted butter
340 g sugar
170 g cocoa powder
110 g milk chocolate drops

3 
1  vanilla essence
1  salt
75 g plain flour

to serve:



vanilla ice cream (optional)





Melt the butter in a pan over a low heat. Line the bowl with buttered foil. Whisk the melted butter, sugar, cocoa powder, flour, eggs, vanilla and salt in a dish. Fold in the chocolate drops. Put the batter into the foil inside the bowl. Close the lid. Select  on the menu. Set the cooking time to 1 hour 30 minutes. Press the  button. The cake should be firm round the edges and slightly gooey in the centre. Serve the cake warm, topped with ice cream.

IRISH STEW WITH GOATS CHEESE DUMPLINGS

STEW





for the stew:

1.8 kg lamb shoulder (cooked)
250 g streaky bacon
950 ml lamb stock
1 large onion, chopped
2  celery, chopped
2  tomato purée





1  olive oil
3  garlic (crushed)
salt and pepper
2 carrots, chopped
2  rosemary, chopped
1  cornflour

for the dumplings:

100 g self raising flour
50 g suet
75 ml water
40 g goat's cheese (soft)
1  dried marjoram

1  baking powder
1  salt
1  dried parsley
1  dried thyme
1  black pepper

for the stew:

Remove the meat from the bone. Cut the meat and bacon into bite-sized chunks. Open the lid. Select  on the menu, and press . Add the stock. Bring to the boil, stirring. Simmer for 10 minutes. Transfer the stock to a jug. Add the oil. Add the onion and sauté till soft. Add the meat, garlic, herbs and other vegetables, and cook for 5 minutes. Add the stock. Add the tomato purée. Press  twice to stop the program. Close the lid. Select .

for the dumplings:

Mix all the ingredients by hand. Divide the mixture into 6 balls. Rest for 20 minutes.

to finish:

Make a smooth paste with the cornflour and a little water in a cup. 30 minutes before cooking ends, open the lid. Stir the paste into the stew. Add the dumplings. Close the lid. Wait till the program ends, then serve. A fabulous bowl of comfort food!



- If you do not have any cooked lamb, you may use raw lamb, with the slow cook program instead of the stew program, then carry on from the dumplings moment.

STEAMED ARTICHOKE

STEAM

1  garlic, peeled and chopped
sprigs of herbs (tarragon, mint, parsley, thyme)

2 globe artichokes
1 lemon

Slice the lemon. Cut the stem flush with the bottom of each artichoke. Cut the top quarter off each artichoke. Discard any damaged leaves. Rub the cut surfaces with a slice of lemon. Put the lemon slices in the basket. Add the sprigs of herbs. Add the garlic. Put the artichoke on top. Fill with water to the 2 level on the scale on the left, inside the bowl. Put the basket on top of the bowl. Close the lid. Select  on the menu, and press . The artichokes are cooked when the outer leaves can be removed easily. Serve warm or cold with a vinaigrette. Amazing!

PEARL BARLEY AND BORLOTTI BEAN ONE-POT MEAL





STEW 



1 	olive oil	1 	borlotti beans
175 g	pearl barley	1	onion, finely chopped
1 	chopped tomatoes	1 	tomato purée
1000 ml	vegetable stock	2 	parsley (chopped)
125 ml	dry red wine		salt and pepper

to serve:



hot chilli oil (optional)

Open the lid. Select  on the menu, and press . Add the stock. Bring to the boil, stirring. Simmer for 10 minutes. Transfer the stock to a jug. Add the oil. Add the onion and sauté till soft. Add the wine and cook for a few minutes. Add the pearl barley, and stir till it begins to take on the colour of the wine. Drain the beans and add them. Add the tomatoes. Add the stock. Press  twice to stop the program. Close the lid. Select  30 minutes before cooking ends, open the lid. Check the amount of liquid in the bowl. Add 150ml of hot water if necessary. Close the lid. Wait till the program ends. Serve with fresh crusty bread and a splash of hot chilli oil.

SYRUP SPONGE PUDDING

STEAM 





115 g	butter	2	 vanilla essence
100 g	caster sugar	1/4 	vanilla essence
175 g	self raising flour	2 	milk
4 	golden syrup		

Beat the eggs in a bowl. Cream the butter and sugar in a bowl. Gradually add the eggs, then the vanilla, then the flour. Stir in the milk. Grease a 1200ml oven-proof bowl. Put the syrup in the bottom of the oven-proof bowl and put the mixture on top. Cover with baking parchment then with foil, and tie the top with string. Open the lid. Put the oven-proof bowl inside the bowl in the appliance. Add enough boiling water into the bowl in the appliance to reach 3cm below the top of the oven-proof bowl. Close the lid. Select  on the menu. Set the cooking time to 1 hour 30 minutes. Press the  button. Wait till the program ends. Invert on to a dish and serve warm. This is a great pudding any time of the year!!

WHITE LOAF

BREAD 

1 	golden syrup	1 	butter
320 ml	milk	1 	dried yeast
500 g	strong white bread flour	1 	salt



Open the lid. Add the milk. Select  on the menu, and press . Let the milk heat till it begins to bubble at the edges. Transfer the milk to a jug. Press  twice to stop the program. Let the milk cool to between 37°C and 45°C. Melt the butter in a pan over a low heat. Mix the flour and salt in a bowl. Add the yeast, butter, and syrup. Add the milk and knead into a ball. If the mix is very sticky, add a little extra flour. Cover and leave in a warm place for 10 minutes. Knead again. Cover and leave in a warm place for 10 minutes. Open the lid. Select  on the menu, and press .

Close the lid. 30 minutes before cooking ends, open the lid. Turn the bread over. This will help to give the top of the loaf a little colour and a crunch. Wait till the program ends. Serve with lashings of butter.



SODA BREAD

BREAD 

1 	soda bread mix		butter
350 ml	water		



Open the lid. Grease the bowl with butter. Select  on the menu. Close the lid. Set the cooking time to 2 hours 15 minutes. Press the  button. Leave it to warm up. Put the soda bread mix into a bowl. Add the water. Mix by hand into a ball. Open the lid. Put the dough into the bowl. Divide the dough into quarters with a plastic spatula. Close the lid. 30 minutes before cooking ends, open the lid. Turn the bread over. This will help to give the top of the loaf a little colour and a crunch. Wait till the program ends. Cool on a wire rack. Serve with salted butter on its own or with a meal.

PORRIDGE

2  oatmeal
1 1/4  salt

to serve:

dark brown sugar



Open the lid. Add the oatmeal, salt, and sugar. Fill with water to the 1 1/2 level on the scale on the right, inside the bowl. Close the lid. Select  on the menu, and press . Wait till the program ends. Serve with milk or cream. Sprinkle with dark brown sugar. If you wish, you may add chopped dried apricots or halved prunes (without stones) 15 minutes before the end of the cooking time. Left over porridge may be kept in the fridge for up to 2 days, then reheated.

PORRIDGE/RISOTTO

water
2  sugar

milk / single cream

NUTTY PORRIDGE

1/2  rolled oats
120 ml milk
1  ground cinnamon



to serve:

golden syrup

PORRIDGE/RISOTTO

water
3  desiccated coconut

nibbed almonds

Open the lid. Add the oats, cinnamon, coconut and milk. Fill with water to the 1/2 level on the scale on the right, inside the bowl. Close the lid. Select  on the menu, and press . Wait till the program ends. Drizzle golden syrup and sprinkle nibbed almonds on top.



MULTI-COOKER BEETROOT RISOTTO





400 g beetroot 2 
250 g arborio/risotto rice
250 ml white wine
900 ml vegetable stock / chicken stock

to finish:



100 ml yoghurt
1  butter



PORRIDGE/RISOTTO

olive oil
1 onion, finely chopped
2  garlic, peeled and chopped
1  thyme, finely chopped
1  parsley (chopped)

Open the lid. Select  on the menu, and press . Add the stock. Bring to the boil, stirring. Simmer for 10 minutes. Transfer the stock to a jug. Press  twice to stop the program. Select  on the menu, and press . Leave it to warm up. Peel the beetroot, and cut into 1cm cubes. Put the beetroot, garlic, and onion in the bowl. Cook till the onions soften. Stir in the rice. Close the lid and cook for 3-4 minutes. Open the lid. Stir in the wine. Close the lid and cook for 3-4 minutes. Open the lid. Add the thyme. Add the stock. Close the lid. Wait till the program ends. Check the rice – it should have a slight bite, but should not be hard . If not quite done, add a little water and cook for a few minutes more. Stir in the butter – this gives the risotto its shine. Serve with a dollop of the yoghurt and sprinkle with parsley. This is a really good as a starter or as a light lunch.

SAVOURY RICE



2  rice
1 stock cube (vegetable)
1 red pepper, deseeded and chopped
1  turmeric



water
2 carrots, chopped
2  celery, chopped
1  peas (optional)





RICE

Open the lid. Put the rice in the bowl. Fill with water to the 2 level on the scale on the left, inside the bowl. Crush the stock cube and stir it into the water. Add the remaining ingredients. Close the lid. Select . Wait till the program ends, then serve. If the rice is not quite done, leave it for a few minutes, with the lid closed, to steam.



TOMATO BIG SOUP



- 1 onion, chopped
- 1  chopped tomatoes
- 1 red pepper, deseeded and chopped
- 550 ml chicken stock
- 1  dried mixed herbs





- 1  olive oil
- 2 chopped tomatoes
- 2 potatoes
- 1  tomato purée
- 1  black pepper

Open the lid. Add the stock. Select  on the menu, and press . Bring to the boil, stirring. Simmer for 10 minutes. Transfer the stock to a jug. Press  twice to stop the program. Peel and dice the potatoes. Select  on the menu, and press . Add the oil. Add the onion and sweet pepper. Cook till the onions soften. Add the stock. Add the remaining ingredients. Close the lid. Wait till the program ends. Adjust the seasoning. Serve with crusty bread.



CHORIZO, CABBAGE AND APPLE SOUP





- ¼ chorizo sausage, finely chopped
- 1 apple
- 2  celery, chopped
- ¼ spring cabbage, finely chopped
- 2  garlic, peeled and chopped
- 1  salt
- 850 ml vegetable stock



- 1 onion, finely chopped
- 2 carrots, chopped
- 2 chopped tomatoes
- 1  tomato purée
- 1  cayenne pepper
- 1  black pepper

Open the lid. Select  on the menu, and press . Sauté the chorizo for 2 minutes. Add the onion and garlic. Cook till the onions soften. Peel, core and chop the apple. Add the remaining ingredients. Press  twice to stop the program. Close the lid. Select  on the menu, and press . Wait till the program ends. This is a great soup and if you leave it overnight in the fridge, the flavour will develop further.

CHICKEN WITH TOMATOES AND MUSHROOMS



- 2 chicken breasts, skinned and boned
- 450 g brown mushrooms, chopped
- 2  garlic, peeled and chopped
- 1  Worcestershire sauce
- 1 salt and pepper



- 1  olive oil
- 1  chopped tomatoes
- 1  tomato sauce
- 1  dried oregano

Open the lid. Select  on the menu, and press . Add the oil. Season the chicken breasts with salt and pepper and put them in the bowl. Turn the meat to seal both sides. Add the garlic and mushrooms. Cook for 3-4 minutes, turning the chicken once. Add the tomatoes, Worcestershire sauce, tomato sauce and oregano. Carry on cooking, turning the chicken once more. Check the chicken is cooked through. Serve with pasta, potatoes or rice. A quick tasty store cupboard meal.

STOUT-BRAISED RIBS WITH MAPLE AND SOY









- 1 kg belly pork ribs
- 350 ml Guinness / stout
- 140 ml beef stock / pork stock
- 60 ml maple syrup / honey





- 1 onion, chopped
- 1  olive oil
- 3  garlic, peeled and chopped
- 2  dark soy sauce

Open the lid. Select  on the menu. Add the oil. Set the cooking time to 1 hour 45 minutes. Press the  button. Add the ribs and brown for 5 minutes – turning occasionally. Remove the ribs. Add the onion and garlic. Cook till the onions soften. Return the ribs to the bowl. Stir in the Guinness, stock, maple syrup and soy sauce. Close the lid. Wait till the program ends. Adjust the seasoning, and serve. A great starter or as part of a pick and mix lunch.

BRISKET ONE-POT MEAL

SLOW COOK 

1 kg	brisket	600 ml	beef stock
2 	tomato purée	2 	rosemary, chopped
2 	garlic, peeled and chopped	2 	dried mixed herbs
2 	bayleaf	1 	chopped tomatoes
50 g	chorizo sausage, sliced	6-8	potatoes (small)
2	carrots		salt and pepper
2	red onions, chopped	2 	Worcestershire sauce
3 	celery		

Leave the skins on the potatoes. Cut the potatoes, carrots and celery into chunks. Season the brisket with salt and pepper. Open the lid. Select  on the menu, and press . Add the stock. Bring to the boil, stirring. Simmer for 10 minutes. Transfer the stock to a jug. Sauté the chorizo for 2 minutes. Add the meat. Brown all over. Add the onions, garlic, potatoes, celery and carrots. If you have any other root vegetables that need using up, add them too. Cook till the onions soften. Add the stock. Add the remaining ingredients. Press  twice to stop the program. Select . Wait till the program ends, then serve. Cooking for 8 hours will do no harm, but it will probably be ready to eat after 5 hours.

Lesen Sie die Anleitung, bewahren Sie sie auf und falls Sie das Gerät an Dritte abgeben, geben Sie auch die Anleitung mit. Entfernen Sie die Verpackung vollständig, bevor Sie das Gerät einschalten.





WICHTIGE SICHERHEITSHINWEISE

Beachten Sie bitte folgende grundlegende Vorsichtsmaßnahmen:

Dieses Gerät ist für die Nutzung von Kindern ab 8 Jahren sowie von Personen mit eingeschränkten physischen, sensorischen oder geistigen Fähigkeiten oder Mangel an Erfahrung und Wissen geeignet, wenn ihnen die Handhabung erklärt wurde/ sie dabei beaufsichtigt werden und ihnen die damit verbundenen Gefahren bewusst sind. Kinder dürfen nicht mit dem Gerät spielen. Reinigung und Benutzerwartung dürfen nicht von Kindern durchgeführt werden, es sei denn sie sind älter als 8 Jahre und werden dabei beaufsichtigt. Bewahren Sie das Gerät und das Kabel außer Reichweite von Kindern unter 8 Jahren auf.

Ist der Gerätestecker oder das Kabel beschädigt, müssen diese durch gesonderte Ersatzteile ersetzt werden, die Sie beim Hersteller oder dessen Servicehändler erhalten.

-  Verwenden Sie das Gerät nicht in der Nähe einer Badewanne, einem Behälter oder anderen Gefäßen, die Wasser enthalten.
-  Bei nicht ordnungsgemäßem Gebrauch kann es zu Verletzungen kommen.
-  Die Oberfläche des Geräts erhitzt sich. Die Restwärme hält die Oberfläche nach dem Gebrauch warm.
 - Kein gefrorenes Fleisch oder Hühnerfleisch in das Gerät geben – es muss vor dem Dämpfen ganz und gar aufgetaut werden.
 - Braten Sie Fleisch, Geflügel und ähnliche Produkte (Hackfleisch, Hamburger, usw.), bis jeweils der Saft abgelaufen ist. Braten Sie den Fisch solange, bis das Fleisch nicht mehr glasig ist
 - Versuchen Sie nicht in dem Gehäuse des Reiskochers zu kochen – kochen Sie nur mit der herausnehmbaren Schüssel.
 - Nicht über die **max**-Markierung befüllen.
 - Decken Sie das Gerät nicht ab und stellen Sie nichts darauf ab.
 - Ziehen Sie erst den Netzstecker aus der Steckdose und trennen Sie dann den Gerätestecker vom Gerät.
 - Wenn Sie das Gerät nicht benutzen, ziehen Sie das Netzkabel aus der Steckdose.
 - Bitte keine Zubehörteile oder Aufsätze verwenden, die nicht von uns geliefert wurden.
 - Benutzen Sie das Gerät ausschließlich zu den in diesen Anweisungen beschriebenen Zwecken.
 - Benutzen Sie das Gerät keinesfalls, wenn es beschädigt ist oder Fehlfunktionen zeigt.

NUR FÜR DEN GEBRAUCH IM HAUSHALT GEEIGNET



ZEICHNUNGEN

- | | |
|-------------------|------------------|
| 1. Bedienfeld | 5. Messbecher |
| 2. Deckel | 6. Korb |
| 3. Öffnungstaste | 7. Schüssel |
| 4. Innerer Deckel | 8. Gerätestecker |



VORBEREITUNG

1. Gerät auf eine stabile, ebene, hitzefeste Oberfläche stellen.
2. Benutzen Sie das Gerät nicht in der Nähe von Vorhängen, Regalen, Schränken oder einem anderen, durch den Dampf leicht zu beschädigenden Gegenstand.
3. Legen Sie Topfhandschuhe (oder Tücher) und eine hitzebeständige Unterlage oder einen Platzteller bereit, um die Schüssel nach dem Kochen abstellen zu können.
4. Geben Sie die Schüssel in den Kocher.
5. Drehen Sie die Schüssel eine viertel Umdrehung hin und zurück, um sicher zu stellen, dass die Schüssel guten Kontakt zum Heizelement hat.



REIS

1. Füllen Sie den Reis mit dem Messbecher in die Schüssel.
2. Nehmen Sie nicht mehr als 10 Tassen Reis.
3. Benutzen Sie die linke Skala innerhalb der Schüssel, die von 2 bis 10 markiert ist.
4. Füllen Sie die Schüssel mit Wasser bis zu der Markierung, die der Zahl an Tassen Reis entspricht, die Sie eingefüllt haben.
5. Den Deckel schließen.
6. Die -Taste betätigen. Die Taste leuchtet auf.
7. Die Anzeige leuchtet an den äußeren Rändern, solange das Essen erwärmt wird.
8. Anschließend erscheint auf der Anzeige die verbleibende Zubereitungszeit (13 Minuten), die rückwärts läuft.
9. Nachdem die Zubereitungszeit abgelaufen ist, schaltet das Gerät in den „Warmhalten“-Modus um.
10. Die -Kontroll-Lampe leuchtet auf.
11. Den Deckel öffnen.
12. Nehmen Sie die Schüssel heraus und stellen Sie sie auf eine hitzebeständige Unterlage oder auf einen Platzteller.
13. Die -Taste betätigen.
14. Wenden Sie den Reis mit dem Pfannenwender, damit der Dampf entweicht.
15. Es kann sein, dass der Reis am Boden der Schüssel gelegentlich verkrustet ist.
16. Möchten Sie sie nicht verwenden, können Sie sie mit Hilfe des Spatels entfernen, nachdem Sie den Reis serviert haben.

LANGSAMES GAREN





1. Fleisch und Gemüse anbraten (Siehe „ANBRATEN/SAUTIEREN/DÄMPFEN/KOCHEN“).
2. Bringen Sie die Kochflüssigkeit zum Kochen (Siehe „ANBRATEN/SAUTIEREN/DÄMPFEN/KOCHEN“).
3. Geben Sie die festen Zutaten in die Schüssel und fügen Sie anschließend die Kochflüssigkeit hinzu.
4. Den Deckel schließen.
5. Die -Taste betätigen. Die Taste leuchtet auf.
6. Auf der Anzeige erscheint die Angabe 8 Stunden, die rückwärts gezählt werden.
7. Nachdem die Zubereitungszeit abgelaufen ist, schaltet das Gerät in den „Warmhalten“-Modus um.
8. Die -Kontroll-Lampe leuchtet auf.
9. Die -Taste betätigen. Den Deckel öffnen. Nehmen Sie das Essen heraus.

STEW KOCHEN





1. Fleisch und Gemüse anbraten (Siehe „ANBRATEN/SAUTIEREN/DÄMPFEN/KOCHEN“).
2. Bringen Sie die Kochflüssigkeit zum Kochen (Siehe „ANBRATEN/SAUTIEREN/DÄMPFEN/KOCHEN“).
3. Geben Sie die festen Zutaten in die Schüssel und fügen Sie anschließend die Kochflüssigkeit hinzu.
4. Den Deckel schließen.
5. Die -Taste betätigen. Die Taste leuchtet auf.
6. Auf der Anzeige erscheint die Angabe 1 Stunde, die rückwärts gezählt wird.
7. Nachdem die Zubereitungszeit abgelaufen ist, schaltet das Gerät in den „Warmhalten“-Modus um.
8. Die -Kontroll-Lampe leuchtet auf.

9. Die -Taste betätigen. Den Deckel öffnen. Nehmen Sie das Essen heraus.

FLEISCH

1. Reiben Sie die Zutaten vollständig mit Speiseöl ein.
2. Streuen Sie Gewürze über die Zutaten.
3. Geben Sie einen Esslöffel Speiseöl in die Schüssel.
4. Geben Sie die Zutaten in die Schüssel.
5. Den Deckel schließen.
6. Die Garzeit ist von der Größe des Produkts abhängig.
7. Bereiten Sie nicht mehr als etwa 500 g Zutaten auf einmal zu.
8. Die empfohlene Zubereitungszeit beträgt 10 Minuten + 10 Minuten je 100 g Rindfleisch.
9. Kochen Sie Schweine- oder Hühnerfleisch mindestens 5, 10, 15, 20, 25, 30 Minuten lang.
10. Wählen Sie mit Hilfe der  Taste  im Menü aus.
11. Wählen Sie die Zubereitungszeit aus. Die Standardzeit beträgt 20 Minuten.
12. Solange die Anzeige aufblinkt, können Sie nur die h und min Tasten benutzen.
13. Bewegen Sie sich mit Hilfe der min Taste durch die Menü-Optionen (10, 15, 20, 25, 5, 10, 15, 20, 25, 30, 35, 40, 45, 50, und 55).
14. Sollte die gewünschte Zubereitungszeit mehr als 1 Stunde betragen, drücken Sie die h Taste.
15. Wenn Sie die Einstellung 1 Stunde rückgängig machen wollen, drücken Sie die h Taste erneut, während die Anzeige aufblinkt.
- Sollten Sie 2 Minuten lang keine Eingabe vornehmen, schaltet das Gerät in den Standby-Modus um.
16. Haben Sie die Zeit eingestellt, drücken Sie .
17. Die Zeit auf der Anzeige läuft rückwärts.
18. Nachdem die Zubereitungszeit abgelaufen ist, schaltet das Gerät in den „Warmhalten“-Modus um.
19. Die -Kontroll-Lampe leuchtet auf.
20. Die -Taste betätigen. Den Deckel öffnen. Nehmen Sie das Essen heraus.

SUPPE

1. Fleisch und Gemüse anbraten (Siehe „ANBRATEN/SAUTIEREN/DÄMPFEN/KOCHEN“).
2. Geben Sie die festen Zutaten in die Schüssel und fügen Sie anschließend die Kochflüssigkeit hinzu.
3. Den Deckel schließen.
4. Wählen Sie mit Hilfe der  Taste  im Menü aus.
5. Wählen Sie die Zubereitungszeit aus. Die Standardzeit beträgt 1 Stunde.
6. Solange die Anzeige aufblinkt, können Sie nur die h und min Tasten benutzen.
7. Bewegen Sie sich mit Hilfe der min Taste durch die Menü-Optionen (10, 15, 20, 25, 5, 10, 15, 20, 25, 30, 35, 40, 45, 50, und 55).
8. Bewegen Sie sich mit Hilfe der h Taste durch die Menü-Optionen (1, 2, 3, 4, und 5).
9. Wenn Sie die Einstellung 5 Stunde rückgängig machen wollen, drücken Sie die h Taste erneut, während die Anzeige aufblinkt.
- Sollten Sie 2 Minuten lang keine Eingabe vornehmen, schaltet das Gerät in den Standby-Modus um.
10. Sie können bei diesem Programm die Timerfunktion nutzen (siehe TIMER).
11. Die -Taste betätigen.
12. Die Zeit auf der Anzeige läuft rückwärts.
13. Nachdem die Zubereitungszeit abgelaufen ist, schaltet das Gerät in den „Warmhalten“-Modus um.
14. Die -Kontroll-Lampe leuchtet auf.
15. Die -Taste betätigen. Den Deckel öffnen. Nehmen Sie das Essen heraus.

JOGHURT

Joghurtkultur

Nehmen Sie 5, 10, 15, 20, 25, 30 ml (2 Esslöffel):

- Nicht-aromatisierten Joghurt mit aktiven Joghurtkulturen – er muss frisch sein (achten Sie auf ein langes Haltbarkeitsdatum). Unterschiedliche Marken führen zu unterschiedlichen Ergebnissen.

Joghurt, den Sie bereits hergestellt haben.

- Die Bakterien werden mit der Zeit schwächer. Sie können diesen Vorgang daher nur 10 Mal wiederholen, danach müssen Sie eine neue Joghurtkultur verwenden.





Gefriergetrocknete Joghurtkultur aus der Apotheke oder aus dem Reformhaus

- Sollten die Packungsanweisungen von den Anweisungen in dieser Anleitung abweichen, halten Sie sich bitte an die Anweisungen auf der Verpackung der Joghurtkultur.



Milch

- Sie benötigen 1 Liter Milch.
- Vollmilch ergibt einen festeren Joghurt als fettarme Milch.
- Damit er noch fester wird, können der flüssigen Milch bis zu 8 Esslöffel Milchpulver beigemischt werden.
- Sie können auch rekonstituiertes Milchpulver oder Kondensmilch aus der Dose verwenden.

Joghurt herstellen.

1. Um zu vermeiden, dass die Bakterien in der Milch mit den Bakterien in der Joghurtkultur konkurrieren, müssen sie abgetötet werden.
2. Während Sie die Milch erhitzen, stellen Sie sicher, dass die Joghurtkultur Raumtemperatur erreicht hat.
3. Den Deckel öffnen.
4. Erhitzen Sie die Milch mit dem Programm DAMPFGAREN (ANBRATEN/SAUTIEREN/DÄMPFEN/KOCHEN) so lange, bis sie fast kocht.
5. Erhitzen Sie die Milch so lange, bis am Rand Bläschen aufsteigen.
6. Lassen Sie die Milch auf 37°C bis 45°C abkühlen.
7. Rühren Sie die Joghurtkultur unter die Milch.
8. Alles muss gut durchgemischt sein, ansonsten wird das Joghurt klumpig.
9. Den Deckel schließen.
10. Wählen Sie mit Hilfe der  Taste  im Menü aus.
11. Wählen Sie die Zubereitungszeit aus. Die Standardzeit beträgt 8 Stunden.
12. Solange die Anzeige aufblinkt, können Sie nur die h und min Tasten benutzen.
13. Bewegen Sie sich mit Hilfe der min Taste durch die Menü-Optionen (10, 15, 20, 25, 5, 10, 15, 20, 25, 30, 35, 40, 45, 50, und 55).
14. Bewegen Sie sich mit Hilfe der h Taste durch die Menü-Optionen (6, 7, 8, 9, und 10).
15. Wenn Sie die Einstellung 10 Stunde rückgängig machen wollen, drücken Sie die h Taste erneut, während die Anzeige aufblinkt.
 - Sollten Sie 2 Minuten lang keine Eingabe vornehmen, schaltet das Gerät in den Standby-Modus um.
16. Sie können bei diesem Programm die Timerfunktion nutzen (siehe TIMER).
17. Die -Taste betätigen.
18. Die Zeit auf der Anzeige läuft rückwärts.
19. Nachdem die Zubereitungszeit abgelaufen ist, schaltet das Gerät in den Standby-Modus um.
20. Der Joghurt wird nicht warmgehalten.
21. Die -Taste betätigen. Den Deckel öffnen. Nehmen Sie das Essen heraus.

BROT

1. Tauen Sie tiefgefrorenen Teig vor dem Gebrauch vollständig auf.
2. Bereiten Sie nicht mehr als etwa 500 g Zutaten auf einmal zu.
3. Bestreichen Sie die Schüssel mit Speiseöl.
4. Geben Sie den Teig in die Schüssel.
5. Den Deckel schließen.
6. Wählen Sie mit Hilfe der  Taste  im Menü aus.
7. Wählen Sie die Zubereitungszeit aus. Die Standardzeit beträgt 3 Stunden.
8. Solange die Anzeige aufblinkt, können Sie nur die h und min Tasten benutzen.
9. Bewegen Sie sich mit Hilfe der min Taste durch die Menü-Optionen (10, 15, 20, 25, 5, 10, 15, 20, 25, 30, 35, 40, 45, 50, und 55).
10. Bewegen Sie sich mit Hilfe der h Taste durch die Menü-Optionen (1, 2, 3, 4, 5, und 6).

11. Wenn Sie die Einstellung 6 Stunde rückgängig machen wollen, drücken Sie die h Taste erneut, während die Anzeige aufblinkt.
- Sollten Sie 2 Minuten lang keine Eingabe vornehmen, schaltet das Gerät in den Standby-Modus um.
12. Sie können bei diesem Programm die Timerfunktion nutzen (siehe TIMER).
13. Die ◊-Taste betätigen.
14. Die Zeit auf der Anzeige läuft rückwärts.
15. Nachdem die Zubereitungszeit abgelaufen ist, schaltet das Gerät in den „Warmhalten“-Modus um.
16. Die ☁-Kontroll-Lampe leuchtet auf.
17. Die Ⓢ-Taste betätigen. Den Deckel öffnen. Nehmen Sie das Essen heraus.

FISCH

1. Reiben Sie die Zutaten vollständig mit Speiseöl ein.
2. Streuen Sie Gewürze über die Zutaten.
3. Geben Sie einen Esslöffel Speiseöl in die Schüssel.
4. Geben Sie die Zutaten in die Schüssel.
5. Den Deckel schließen.
6. Die Garzeit ist von der Größe des Produkts abhängig.
7. Bereiten Sie nicht mehr als etwa 500 g Zutaten auf einmal zu.
8. Die empfohlene Zubereitungszeit beträgt 10 Minuten je 100 g Gewicht.
9. Wählen Sie mit Hilfe der ? Taste  im Menü aus.
10. Wählen Sie die Zubereitungszeit aus. Die Standardzeit beträgt 20 Minuten.
11. Solange die Anzeige aufblinkt, können Sie nur die h und min Tasten benutzen.
12. Bewegen Sie sich mit Hilfe der min Taste durch die Menü-Optionen (10, 15, 20, 25, 5, 10, 15, 20, 25, 30, 35, 40, 45, 50, und 55).
13. Sollte die gewünschte Zubereitungszeit mehr als 1 Stunde betragen, drücken Sie die h Taste.
14. Wenn Sie die Einstellung 1 Stunde rückgängig machen wollen, drücken Sie die h Taste erneut, während die Anzeige aufblinkt.
- Sollten Sie 2 Minuten lang keine Eingabe vornehmen, schaltet das Gerät in den Standby-Modus um.
15. Haben Sie die Zeit eingestellt, drücken Sie ◊.
16. Die Zeit auf der Anzeige läuft rückwärts.
17. Nachdem die Zubereitungszeit abgelaufen ist, schaltet das Gerät in den „Warmhalten“-Modus um.
18. Die ☁-Kontroll-Lampe leuchtet auf.
19. Am besten nehmen Sie das Essen nach der Zubereitung so schnell wie möglich heraus, damit es nicht austrocknet.
20. Die Ⓢ-Taste betätigen. Den Deckel öffnen. Nehmen Sie das Essen heraus.

DAMPFGAREN

1. Füllen Sie kaltes Wasser bis zur Markierung 6 in die Schüssel.
2. Stellen Sie den Korb auf die Schüssel und legen Sie die Lebensmittel in den Korb.
3. Schneiden Sie, für gleichmäßiges Kochen, das Essen in etwa gleichgroße Stücke.
4. Legen Sie Erbsen oder andere Lebensmittel, die aufgehen oder ins Wasser fallen können, in ein Päckchen aus Aluminiumfolie.
5. Seien vorsichtig beim Herausnehmen des Gitters – benutzen Sie Topfhandschuhe und Plastiklöffel.
6. Den Deckel schließen.
7. Wählen Sie mit Hilfe der ? Taste  im Menü aus.
8. Wählen Sie die Zubereitungszeit aus. Die Standardzeit beträgt 30 Minuten.
- Diese Zutaten sollten innerhalb der Standardzeit zubereitet werden:

Essen (frisch)	Menge
Grüne Bohnen	200g
Rosenkohl	200g
Karotten (geschält)	200g
Kartoffeln (geviertelt)	400g
Broccoli	200g
Kohl	Viertel
Mais	2

9. Solange die Anzeige aufblinkt, können Sie nur die h und min Tasten benutzen.
10. Bewegen Sie sich mit Hilfe der min Taste durch die Menü-Optionen (5, 10, 15, 20, 25, 30, 35, 40, 45, 50, und 55).
11. Bewegen Sie sich mit Hilfe der h Taste durch die Menü-Optionen (1, und 2).
12. Wenn Sie die Einstellung 2 Stunde rückgängig machen wollen, drücken Sie die h Taste erneut, während die Anzeige aufblinkt.
 - Sollten Sie 2 Minuten lang keine Eingabe vornehmen, schaltet das Gerät in den Standby-Modus um.
13. Sie können bei diesem Programm die Timerfunktion nutzen (siehe TIMER).
14. Die v-Taste betätigen.
15. Die Zeit auf der Anzeige läuft rückwärts.
16. Nachdem die Zubereitungszeit abgelaufen ist, schaltet das Gerät in den „Warmhalten“-Modus um.
17. Die W-Kontroll-Lampe leuchtet auf.
18. Am besten nehmen Sie das Essen nach der Zubereitung so schnell wie möglich heraus, damit es nicht zu weich wird.
19. Die w-Taste betätigen. Den Deckel öffnen. Nehmen Sie das Essen heraus.

ANBRATEN/SAUTIEREN/DÄMPFEN/KOCHEN

- Sie können das Programm DAMPFGAREN  mit der Standardeinstellung – ohne Deckel – 5, 10, 15, 20, 25, 30 Minuten lang als Pfanne für hohe Temperaturen benutzen, bevor Sie mit einem anderen Programm fortfahren.
- Verwenden Sie es unter Einsatz von ein wenig Öl, um Fleisch und Gemüse anzubraten, um Zutaten zu sautieren, um Zwiebeln, Sellerie, Lauch etc. zu dämpfen.
- Verwenden Sie dabei Wasser oder Brühe, um die Kochflüssigkeiten vorzuwärmen.
- Sobald sie zum Hauptprogramm wechseln, ist das Gerät aufgewärmt und einige oder alle Ihrer Zutaten befinden sich bereits in der Schüssel.
- Sie müssen anschließend nicht mehr die Pfanne abwaschen, die Sie ansonsten bei der Vorbereitung verwendet hätten.



PORRIDGE/RISOTTO

Füllen Sie das Getreide (Reis. Haferflocken, Gerste etc.) mit dem Messbecher in die Schüssel.

Porridge

- Benutzen Sie die rechte Skala innerhalb der Schüssel, die von ½ bis 1½ markiert ist.
- Nicht über die **max**-Markierung befüllen.

Congee (Reisbrei)

- Benutzen Sie die mittlere Skala innerhalb der Schüssel, die von 1 bis 3 markiert ist.
 - Nicht über die **max**-Markierung befüllen.
1. Füllen Sie die Schüssel mit Wasser bis zu der Markierung, die der Zahl an Tassen Getreide entspricht.
 2. Den Deckel schließen.
 3. Wählen Sie mit Hilfe der  Taste  im Menü aus.



4. Wählen Sie die Zubereitungszeit aus. Die Standardzeit beträgt 1 Stunde.
5. Solange die Anzeige aufblinkt, können Sie nur die h und min Tasten benutzen.
6. Bewegen Sie sich mit Hilfe der min Taste durch die Menü-Optionen (5, 10, 15, 20, 25, 30, 35, 40, 45, 50, und 55).
7. Bewegen Sie sich mit Hilfe der h Taste durch die Menü-Optionen (1, 2, 3, und 4).
8. Wenn Sie die Einstellung 4 Stunde rückgängig machen wollen, drücken Sie die h Taste erneut, während die Anzeige aufblinkt.
 - Sollten Sie 2 Minuten lang keine Eingabe vornehmen, schaltet das Gerät in den Standby-Modus um.
9. Sie können bei diesem Programm die Timerfunktion nutzen (siehe TIMER).
10. Die ◀-Taste betätigen.
11. Die Zeit auf der Anzeige läuft rückwärts.
12. Nachdem die Zubereitungszeit abgelaufen ist, schaltet das Gerät in den „Warmhalten“-Modus um.
13. Die 🔌-Kontroll-Lampe leuchtet auf.
14. Die ⏪-Taste betätigen. Den Deckel öffnen. Nehmen Sie das Essen heraus.

Risotto

Halten Sie sich an das Rezept, das weiter hinten in dieser Broschüre aufgeführt ist.

KUCHEN 🍰

1. Tauen Sie tiefgefrorenen Teig vor dem Gebrauch vollständig auf.
2. Befüllen Sie die Schüssel nicht mehr als etwa halbvoll.
3. Bestreichen Sie die Schüssel mit Speiseöl.
4. Geben Sie den Teig in die Schüssel.
5. Den Deckel schließen.
6. Wählen Sie mit Hilfe der ⌚ Taste 🍰 im Menü aus.
7. Wählen Sie die Zubereitungszeit aus. Die Standardzeit beträgt 40 Minuten.
8. Die Standardzeit beträgt 40 Minuten.
9. Solange die Anzeige aufblinkt, können Sie nur die h und min Tasten benutzen.
10. Bewegen Sie sich mit Hilfe der min Taste durch die Menü-Optionen (5, 10, 15, 20, 25, 30, 35, 40, 45, 50, und 55).
11. Bewegen Sie sich mit Hilfe der h Taste durch die Menü-Optionen (1, und 2).
12. Wenn Sie die Einstellung 2 Stunde rückgängig machen wollen, drücken Sie die h Taste erneut, während die Anzeige aufblinkt.
 - Sollten Sie 2 Minuten lang keine Eingabe vornehmen, schaltet das Gerät in den Standby-Modus um.
13. Haben Sie die Zeit eingestellt, drücken Sie ◀.
14. Die Zeit auf der Anzeige läuft rückwärts.
15. Nachdem die Zubereitungszeit abgelaufen ist, schaltet das Gerät in den „Warmhalten“-Modus um.
16. Die 🔌-Kontroll-Lampe leuchtet auf.
17. Am besten nehmen Sie das Essen nach der Zubereitung so schnell wie möglich heraus, damit es nicht zu weich wird.
18. Die ⏪-Taste betätigen. Den Deckel öffnen. Nehmen Sie das Essen heraus.

WARMHALTEN

- Möchten Sie die Funktion „Warmhalten“ nach einem Programm einsetzen, das diese Funktion nicht unterstützt, drücken Sie 🔌 genau dann, wenn auf der Anzeige nur die 🔌 Lampe aufleuchtet.
- Drücken Sie ⏪ um diese Funktion zu verlassen.

PFLEGE UND INSTANDHALTUNG

1. Ziehen Sie den Netzstecker vom Strom und lassen Sie das Gerät abkühlen.
2. Ziehen Sie erst den Netzstecker aus der Steckdose und trennen Sie dann den Gerätestecker vom Gerät.
3. Halten Sie das obere Ende des Filters bei geschlossenem Deckel fest und heben Sie ihn aus dem Deckel heraus (ABB. A).
4. Drehen Sie ihn um, damit Sie die Markierungen vorne am Rand sehen können

5. Halten Sie den Filterdeckel fest und drehen Sie den Filter in Richtung offenes Schloss  (ABB. B).
6. Drücken Sie auf die Laschen unten im inneren Deckel und ziehen Sie ihn vom Gerät. (ABB. C).
7. Reinigen Sie die abnehmbaren Teile nur mit der Hand.
8. Alle Oberflächen mit einem sauberen, feuchten Tuch abwischen.
9. Das Grundgerät und seine Einzelteile dürfen nicht in einer Spülmaschine gereinigt werden.
10. Setzen Sie den Filter wieder zusammen und setzen Sie ihn wieder in den Deckel ein.
11. Setzen Sie den inneren Deckel wieder in den Deckel ein.









RECYCLING







Um negative Auswirkungen auf Umwelt und Gesundheit durch gefährliche Stoffe zu vermeiden, dürfen Geräte sowie wiederaufladbare und nicht wiederaufladbare Batterien, die mit einem dieser Symbole gekennzeichnet sind, nicht über den normalen Hausmüll entsorgt werden. Entsorgen Sie elektrische und elektronische Produkte und gegebenenfalls wiederaufladbare und nicht wiederaufladbare Batterien immer an einer offiziellen Recyclingstelle.

REZEPTE

	Esslöffel (15ml)
	Teelöffel (5ml)
g	Gramm
ml	Milliliter
	Messbecher
	Stange/Rippe (Sellerie)
	Hand voll
	Ei, mittel (53-63 g)

	Prise
	Bund
	Zweig
	Zehe/Zehen
	Dose
	Glas
	Päckchen (7 g)
	Ei, groß (63-73 g)

GEMÜSE-COUSCOUS-CHILI

1	rote Zwiebel, gehackt
1	große Zwiebel, gehackt
2 	Knoblauch, geschält und gehackt
1	rote Paprika, entkernt und gehackt
1	gelbe Paprika, entkernt und gehackt
1	orangefarbene Paprika, entkernt und gehackt
1 	gemahlener Koriander
1 	Tomatenpüree
850 ml	Gemüsebrühe
2 	pikante Tomatensoße
120-140 ml	Couscous





Serviervorschlag:

geriebener Käse
kleiner Bund Koriander, gehackt

LANGSAMES GAREN

1 	Olivenöl
1 	Limabohnen
1 	Cannellini-Bohnen
1 	grüne Jalapeños
1 	Kidneybohnen
1 	Tomaten in Stücken
2 	Kreuzkümmel gemahlen
1 	Zucker
2 	Chilipulver
2 	getrockneter Oregano

Sauerrahm

Den Deckel öffnen. Geben Sie das Öl hinzu. Wählen Sie im Menü  aus und drücken Sie . Fügen Sie die Zwiebel und den Knoblauch hinzu. Lassen Sie das Ganze solange kochen, bis die Zwiebeln gedünstet sind. Gießen Sie das Wasser von den Bohnen ab und geben Sie sie hinzu. Halten Sie den Couscous zurück. Geben Sie die restlichen Zutaten hinzu. Drücken Sie  zweimal, um das Programm anzuhalten. Den Deckel schließen. Wählen Sie . Geben Sie den Couscous 30 Minuten, bevor der Kochvorgang beendet ist, hinzu. Ist der Kochvorgang bereits beendet, wählen Sie  im Menü und lassen Sie das Ganze weitere 20 Minuten kochen. Servieren Sie das Ganze mit einer Hand voll Käse, einem Spritzer Sauerrahm und ein wenig frischem Koriander. Für ein klassisches vegetarisches Chili lassen Sie einfach den Couscous weg.

HAUSGEMACHTER JOGHURT

JOGHURT





1200 ml Milch

100 ml Joghurt

Mit geschmack







50 g tiefgefrorener sommerlicher Beerenmix







1  Honig





Den Deckel öffnen. Geben Sie die Milch hinzu. Wählen Sie im Menü  aus und drücken Sie . Erhitzen Sie die Milch so lange, bis am Rand Bläschen aufsteigen. Drücken Sie  zweimal, um das Programm anzuhalten. Lassen Sie die Milch auf 37°C bis 45°C abkühlen. Rühren Sie den Joghurt in die Milch. Alles muss gut durchgemischt sein, ansonsten wird das Joghurt klumpig. Den Deckel schließen. Wählen Sie im Menü  aus und drücken Sie . Warten Sie, bis das Programm beendet ist. Stellen Sie den Joghurt in den Kühlschrank, bis er ganz abgekühlt ist. Erwärmen Sie die Beeren langsam in einer Pfanne. Geben Sie den Honig hinzu. Sobald die Beeren zusammenfallen, nehmen Sie sie vom Herd, lassen Sie sie abkühlen und vermengen Sie das Ganze mit dem Joghurt. Wenn Sie den Joghurt aufheben wollen, müssen Sie die Gläser, die Sie verwenden, sterilisieren. Erhitzen Sie sie bei 100 °C 10 Minuten lang im Backofen. Der Joghurt hält sich im Kühlschrank bis zu 2 Wochen.

FEURIGES NEW YORK-BEEF-CHILI

STEW



450 g Rindschmorbraten
3  Knoblauch, geschält und gehackt
2  Kreuzkümmel gemahlen
1  Cayennepfeffer
1  geräuchertes Paprika- / Chipotle-Pulver
1 grüne Paprika
1  Salz
1  Basilikumblätter, grob gehackt





1  Olivenöl
2 Zwiebeln, gehackt
2  Chilipulver
2  Tomatensoße
2  Tomaten
1  Lorbeerblatt
1  schwarzer Pfeffer
1  Kidneybohnen



Den Deckel öffnen. Geben Sie das Öl hinzu. Wählen Sie im Menü  aus und drücken Sie . Schneiden Sie das Rindfleisch, die Tomaten und die Paprika in mundgerechte Stücke. Braten Sie das Fleisch an und nehmen Sie es vom Herd. Geben Sie die Zwiebeln, den Knoblauch und die Kräuter hinzu. Lassen Sie das Ganze solange kochen, bis die Zwiebeln gedünstet sind. Fügen Sie das Fleisch hinzu. Halten Sie die Bohnen zurück. Geben Sie die restlichen Zutaten hinzu. Drücken Sie  zweimal, um das Programm anzuhalten. Den Deckel schließen. Wählen Sie . Geben Sie die Bohnen 30 Minuten, bevor der Kochvorgang beendet ist, hinzu. Sollte das Fleisch nach Programmende noch etwas zäh sein, geben Sie eine Tasse Wasser hinzu und lassen Sie das Programm für Fleisch weitere 30 Minuten laufen.

MAROKKANISCHE FISCHTAJINE



FISCH

2  Knoblauch, geschält und gehackt
1 rote Paprika, entkernt und gehackt
2 Tomaten in Stücken
1  gemahlener Ingwer
1 Zimtstange
120 ml Weißwein
120 ml Fischbrühe
675 g Fisch (Dorsch/Schellfisch/Lachsfilet)
1 kleiner Bund Koriander, gehackt



1 Zwiebeln, gehackt
2  Sellerie, gehackt
1  Kreuzkümmel gemahlen
1  Kurkurma
1  Harissa-Paste
1  Tomatenpüree
1 Zitrone
1  grüne Oliven
Salz und Pfeffer





Halten Sie den Koriander zurück. Den Deckel öffnen. Geben Sie die restlichen Zutaten hinzu. Den Deckel schließen. Wählen Sie im Menü  aus und drücken Sie . Lassen Sie das Ganze so lange garen, bis der Fisch zart ist (40 – 60 Minuten) Drücken Sie  zweimal, um das Programm anzuhalten. Geben Sie den Koriander hinzu. Schmecken Sie das Gericht ab und servieren Sie das Ganze. Couscous passt sehr gut zu diesem Gericht.

SCHWEINSHAXEN-SUPPE MIT SCHÄLERBSEN



1150 ml	Hühnerbrühe
225 g	Schälerbsen
1 	Sellerie, gehackt
1 	Thymian, fein gehackt
1	Schweinschaxe

LANGSAMES GAREN



1	Zwiebeln, fein gehackt
1	Möhren, gehackt
2 	Knoblauch (gerieben)
1 	Lorbeerblatt
	schwarzer Pfeffer



Den Deckel öffnen. Geben Sie die Brühe hinzu. Wählen Sie im Menü  aus und drücken Sie . Unter Rühren zum Kochen bringen. 10 Minuten köcheln lassen. Geben Sie die restlichen Zutaten hinzu. Drücken Sie  zweimal, um das Programm anzuhalten. Den Deckel schließen. Wählen Sie . Warten Sie, bis das Programm beendet ist. Nehmen Sie die Schweinschaxe heraus. Entfernen Sie Haut und Knochen. Schneiden Sie das Fleisch in Würfel. Entfernen Sie den Lorbeer. Zerdrücken Sie die Schälerbsen mit der Rückseite eines Holzlöffels. Fügen Sie das Fleisch hinzu. Schmecken Sie das Gericht ab und servieren Sie das Ganze. Himmlischer Geschmack in der Schüssel!

LACHS MIT WÜRZIGER KRUSTE

2	Lachsfilets (mit Haut)
1 	Paprikapulver
1/2 	Kreuzkümmel gemahlen
1 	weicher brauner Zucker

FISCH



1 	Olivenöl
1 	Chilipulver
1 	Salz und Pfeffer
1	Zitrone

Vermengen Sie die Paprika, das Chilipulver, den Kreuzkümmel, Zucker, Salz und Pfeffer miteinander. Streuen Sie das Ganze über die Lachsfilets. Den Deckel öffnen. Geben Sie das Öl hinzu. Wählen Sie im Menü  aus und drücken Sie . Warten Sie ein paar Minuten, bis das Öl heiß ist. Geben Sie die Filets mit der Haut nach unten hinzu. Den Deckel schließen. Dieses Gericht verbindet das Dampfgaren und Braten von Fischstücken perfekt miteinander und die Haut wird richtig knusprig. Servieren Sie das Ganze mit einem Stückchen Zitrone. Ein wunderbar leichtes Gericht.

SCHOKOLADEN-BROWNIE-KUCHEN

170 g	ungesalzene Butter
340 g	Zucker
170 g	Kakaopulver
110 g	Schokotropfen aus Vollmilch



KUCHEN

3	 Vanillearoma
1 	Salz
75 g	Weizenmehl

Serviervorschlag:

Vanilleeis (freigestellt)



Zerlassen Sie Butter bei niedriger Hitze in einer Pfanne. Legen Sie gebutterte Folie in der Schüssel aus. Verquirlen Sie die geschmolzene Butter, den Zucker, das Kakaopulver, das Mehl, die Eier, Vanille und Salz in einer Schüssel. Heben Sie die Schokotropfen unter.





Geben Sie den Teig auf die Folie in der Schüssel. Den Deckel schließen. Wählen Sie  im Menü. Stellen Sie die Zubereitungszeit auf 1 Stunde 30 Minuten ein. Die -Taste betätigen. Der Kuchen sollte am Rand fest und in der Mitte leicht zähflüssig sein. Servieren Sie den Kuchen warm und zusammen mit Eiscreme.

IRISH STEW MIT ZIEGENKÄSEKNÖDELN

STEW





für den Stew:

1.8 kg	Lammschulter (gekocht)
250 g	Speckscheiben
950 ml	Lammbrühe
1	große Zwiebel, gehackt
2 	Sellerie, gehackt
2 	Tomatenpüree

1 	Olivenöl
3 	Knoblauch (gerieben)
	Salz und Pfeffer
2	Möhren, gehackt
2 	Rosmarin gehackt
1 	Speisestärke

für die Knödel:

100 g	Backpulver
50 g	Rindertalg
75 ml	Wasser
40 g	Ziegenkäse (weich)
1 	getrocknete Majoranblätter

1 	Backpulver
1 	Salz
1 	Getrocknete Petersilie
1 	getrockneter Thymian
1 	schwarzer Pfeffer

für den Stew:

Trennen Sie das Fleisch von den Knochen. Schneiden Sie das Fleisch und den Speck in mundgerechte Stücke. Den Deckel öffnen. Wählen Sie im Menü aus und drücken Sie . Geben Sie die Brühe hinzu. Unter Rühren zum Kochen bringen. 10 Minuten köcheln lassen. Füllen Sie die Brühe in einen Krug um. Geben Sie das Öl hinzu. Fügen Sie die Zwiebel hinzu und lassen Sie sie kurz anbraten. Geben Sie das Fleisch, den Knoblauch, die Kräuter und das restliche Gemüse hinzu und lassen Sie alles 5 Minuten lang kochen. Geben Sie die Brühe hinzu. Geben Sie das Tomatenmark hinzu. Drücken Sie zweimal, um das Programm anzuhalten. Den Deckel schließen. Wählen Sie .

für die Knödel:

Vermengen Sie sämtliche Zutaten mit der Hand. Teilen Sie die Masse in 6 Kugeln auf. Lassen Sie den Teig 20 Minuten stehen.

zum Schluss:

Verrühren Sie die Speisestärke mit ein wenig Wasser in einer Tasse zu einer glatten Masse. Öffnen Sie 30 Minuten, bevor der Kochvorgang beendet ist, den Deckel. Rühren Sie die Masse in den Stew unter. Geben Sie die Knödel hinzu. Schließen Sie den Deckel. Warten Sie, bis das Programm beendet ist, und servieren Sie anschließend. Eine Schüssel voll wunderbarem Essen für die Seele!

- Sollten Sie kein gekochtes Lamm haben, können Sie auch rohes Lamm verwenden. Wählen Sie statt dem Programm für Stew das Programm für langsames Garen und folgen Sie den Schritten, die nach Hinzugabe der Knödel folgen.

DAMPFGEARTE ARTISCHOCKE

1 Knoblauch, geschält und gehackt
Kräuterzweige (Estragon, Minze, Petersilie, Thymian)

2 Artischocken
1 Zitrone

DAMPFGAREN

Schneiden Sie die Zitrone in Scheiben. Schneiden Sie den überschüssigen Stiel vom Ende jeder Artischocke ab. Schneiden Sie das obere Viertel jeder Artischocke ab. Entfernen Sie beschädigte Blätter. Reiben Sie die abgeschnittenen Oberflächen mit einer Zitronenscheibe ein. Legen Sie die Zitronenscheiben in den Korb. Geben Sie die Kräuterzweige hinzu. Geben Sie den Knoblauch hinzu. Legen Sie die Artischocke darüber. Füllen Sie bis zur Markierung 2 auf der linken Skala innerhalb der Schüssel Wasser ein. Stellen Sie den Korb auf die Schüssel. Den Deckel schließen. Wählen Sie im Menü aus und drücken Sie . Die Artischocken sind gar, wenn Sie die äußeren Blätter leicht abziehen können. Servieren Sie das Ganze warm oder kalt mit einer Vinaigrette. Fantastisch!

GRAUPEN- UND BORLOTTI-BOHNENEINTOPF

1 Olivenöl
175 g Graupen
1 Tomaten in Stücken
1000 ml Gemüsebrühe
125 ml trockener Rotwein

1 Borlotti-Bohnen
1 Zwiebeln, fein gehackt
1 Tomatenpüree
2 Petersilie (gehackt)
Salz und Pfeffer





STEW



Serviervorschlag: scharfes Chili-Öl (freigestellt)

Den Deckel öffnen. Wählen Sie im Menü aus und drücken Sie . Geben Sie die Brühe hinzu. Unter Rühren zum Kochen bringen. 10 Minuten köcheln lassen. Füllen Sie die Brühe in einen Krug um. Geben Sie das Öl hinzu. Fügen Sie die Zwiebel hinzu und lassen Sie sie kurz anbraten. Geben Sie den Wein hinzu und lassen Sie alles einige Minuten lang kochen. Geben Sie die Graupen hinzu und rühren Sie so lange, bis das Ganze die Farbe des Weins annimmt. Gießen Sie das Wasser von den Bohnen ab und geben Sie sie hinzu. Geben Sie die Tomaten hinzu. Geben Sie die Brühe hinzu. Drücken Sie zweimal, um das Programm anzuhalten. Den Deckel schließen. Wählen Sie . Öffnen Sie 30 Minuten, bevor der Kochvorgang beendet ist, den Deckel. Überprüfen Sie die Wassermenge in der Schüssel. Geben Sie bei Bedarf 150 ml heißes Wasser hinzu. Den Deckel schließen. Warten Sie, bis das Programm beendet ist. Servieren Sie das Ganze mit knusprigem Brot und einem Spritzer scharfem Chili-Öl.

SPONGE PUDDING MIT SIRUP





DAMPFGAREN 





115 g	Butter	2	
100 g	Feiner Zucker	¼ 	Vanillearoma
175 g	Backpulver	2 	Milch
4 	Golden Syrup (Zuckerrübensirup)		

Schlagen Sie die Eier in einer Schüssel auf. Schlagen Sie die Butter und den Zucker in einer Schüssel. Geben Sie nach und nach Eier, Vanille und das Mehl hinzu. Rühren Sie die Milch unter. Fetten Sie eine 1200 ml große hitzebeständige Schüssel ein. Füllen Sie den Sirup in die hitzebeständige Schüssel und geben Sie die Masse darüber. Decken Sie das Ganze mit Backpapier und anschließend mit Folie ab, und befestigen Sie alles mit einem Bindfaden. Den Deckel öffnen. Stellen Sie die hitzebeständige Schüssel in die Schüssel des Geräts. Füllen Sie so viel Wasser in die Schüssel des Geräts, dass es bis 3 cm unter den Rand der hitzebeständigen Schüssel reicht. Den Deckel schließen. Wählen Sie  im Menü. Stellen Sie die Zubereitungszeit auf 1 Stunde 30 Minuten ein. Die -Taste betätigen. Warten Sie, bis das Programm beendet ist. Drehen Sie den Kuchen auf einem Teller um und servieren Sie ihn warm. Ein tolles Rezept für jede Jahreszeit!

WEISSBROT

BROT 



1 	Golden Syrup (Zuckerrübensirup)	1 	Butter
320 ml	Milch	1 	Trockenhefe
500 g	Weizenmehl	1 	Salz

Den Deckel öffnen. Geben Sie die Milch hinzu. Wählen Sie im Menü  aus und drücken Sie . Erhitzen Sie die Milch so lange, bis am Rand Bläschen aufsteigen. Füllen Sie die Milch in einen Krug um. Drücken Sie  zweimal, um das Programm anzuhalten. Lassen Sie die Milch auf 37°C bis 45°C abkühlen. Zerlassen Sie Butter bei niedriger Hitze in einer Pfanne. Vermengen Sie das Mehl und das Salz in einer Schüssel. Geben Sie die Hefe, Butter und den Sirup hinzu. Geben Sie die Milch hinzu und kneten Sie das Ganze zu einer Kugel. Ist die Masse sehr klebrig, geben Sie ein wenig mehr Mehl hinzu. Decken Sie das Ganze ab und lassen Sie den Teig 10 Minuten lang an einem warmen Platz gehen. Kneten Sie das Ganze noch einmal durch. Decken Sie das Ganze ab und lassen Sie den Teig 10 Minuten lang an einem warmen Platz gehen. Den Deckel öffnen. Wählen Sie im Menü  aus und drücken Sie . Den Deckel schließen. Öffnen Sie 30 Minuten, bevor der Kochvorgang beendet ist, den Deckel. Drehen Sie das Brot um. Auf diese Weise wird das Brot oben ein wenig braun und knusprig. Warten Sie, bis das Programm beendet ist. Servieren Sie das Ganze mit Butter.

SODA BREAD (BROTREZEPT MIT NATRON)

BROT 

1 	Brotbackmischung mit Natron	Butter
350 ml	Wasser	

Den Deckel öffnen. Fetten Sie die Schüssel mit Butter ein. Wählen Sie  im Menü. Den Deckel schließen. Stellen Sie die Zubereitungszeit auf 2 Stunden 15 Minuten ein. Die -Taste betätigen. Lassen Sie das Gerät aufheizen. Geben Sie die Brotbackmischung mit Natron in eine Schüssel. Geben Sie das Wasser hinzu. Vermengen Sie das Ganze mit der Hand zu einer Kugel. Den Deckel öffnen. Geben Sie den Teig in die Schüssel. Teilen Sie den Teig mit einer Teigspatel aus Kunststoff in vier Stücke. Den Deckel schließen. Öffnen Sie 30 Minuten, bevor der Kochvorgang beendet ist, den Deckel. Drehen Sie das Brot um. Auf diese Weise wird das Brot oben ein wenig braun und knusprig. Warten Sie, bis das Programm beendet ist. Auf einem Backgitter auskühlen lassen. Servieren Sie das Ganze mit gesalzener Butter ohne Beilagen oder zusammen mit einem Gericht.

PORRIDGE



PORRIDGE/RISOTTO 

2 	Haferflocken	Wasser	
1¼ 	Salz	2 	Zucker



Serviervorschlag:

brauner Zucker

Milch / Sahne

Den Deckel öffnen. Geben Sie die Haferflocken, Salz und Zucker hinzu. Füllen Sie bis zur Markierung 1½ auf der rechten Skala innerhalb der Schüssel Wasser ein. Den Deckel schließen. Wählen Sie im Menü  aus und drücken Sie . Warten Sie, bis das Programm beendet ist. Servieren Sie das Ganze mit Milch oder Sahne. Streuen Sie dunklen braunen Zucker darüber. Wenn Sie möchten, können Sie kleingehackte getrocknete Aprikosen oder halbierte Backpflaumen (entsteint) 15 Minuten, bevor die Zubereitungszeit endet, hinzugeben. Reste vom Porridge können bis zu 2 Tage im Kühlschrank aufbewahrt und wieder aufgewärmt werden.

NUSSPORRIDGE

- ½  Haferflocken
- 120 ml Milch
- 1  gemahlener Zimt



Serviervorschlag:

Golden Syrup (Zuckerrübensirup)

PORRIDGE/RISOTTO

- Wasser
- 3  Kokosraspeln

gehackte Mandeln

Den Deckel öffnen. Geben Sie die Haferflocken, den Zimt, die Kokosraspeln und die Milch hinzu. Füllen Sie bis zur Markierung ½ auf der rechten Skala innerhalb der Schüssel Wasser ein. Den Deckel schließen. Wählen Sie im Menü  aus und drücken Sie . Warten Sie, bis das Programm beendet ist. Träufeln Sie Golden Syrup (Zuckerrübensirup) über das Ganze und streuen Sie die gehackten Mandeln darüber.





ROTE-BEETE-RISOTTO IM MULTI-COOKER





- 400 g Rote Beete
- 250 g Arborio-/Risotto-Reis
- 250 ml Weißwein
- 900 ml Gemüsebrühe / Hühnerbrühe

zum Schluss:

- 100 ml Joghurt
- 1  Butter



PORRIDGE/RISOTTO

- 2  Olivenöl
- 1 Zwiebeln, fein gehackt
- 2  Knoblauch, geschält und gehackt
- 1  Thymian, fein gehackt
- 1  Petersilie (gehackt)



Den Deckel öffnen. Wählen Sie im Menü  aus und drücken Sie . Geben Sie die Brühe hinzu. Unter Rühren zum Kochen bringen. 10 Minuten köcheln lassen. Füllen Sie die Brühe in einen Krug um. Drücken Sie  zweimal, um das Programm anzuhalten. Wählen Sie im Menü  aus und drücken Sie . Lassen Sie das Gerät aufheizen. Schälen Sie die Rote Beete und schneiden Sie sie in 1 cm große Würfel. Geben Sie die Rote Beete, den Knoblauch und die Zwiebeln in eine Schüssel. Lassen Sie das Ganze solange kochen, bis die Zwiebeln gedünstet sind. Rühren Sie den Reis unter. Schließen Sie den Deckel und lassen Sie das Ganze 3 – 4 Minuten lang kochen.

Den Deckel öffnen. Rühren Sie den Wein unter. Schließen Sie den Deckel und lassen Sie das Ganze 3 – 4 Minuten lang kochen. Den Deckel öffnen. Geben Sie den Thymian hinzu. Geben Sie die Brühe hinzu. Den Deckel schließen. Warten Sie, bis das Programm beendet ist. Schauen Sie nach dem Reis – er sollte bissfest sein, aber nicht hart. Wenn er noch nicht ganz gar ist, geben Sie ein wenig Wasser hinzu und lassen Sie das Ganze ein paar Minuten länger kochen. Rühren Sie die Butter unter – dadurch erhält das Risotto seinen Glanz. Servieren Sie das Ganze mit einem Klecks Joghurt und ein wenig Petersilie. Eignet sich hervorragend als Vorspeise oder als leichtes Mittagessen.

WÜRZREIS

- 2  Reis
- 1 Brühwürfel (Gemüse)
- 1 rote Paprika, entkernt und gehackt
- 1  Kurkuma

REIS

- Wasser
- 2 Möhren, gehackt
- 2  Sellerie, gehackt
- 1  Erbsen (freigestellt)

Den Deckel öffnen. Geben Sie den Reis in eine Schüssel. Füllen Sie bis zur Markierung 2 auf der linken Skala innerhalb der Schüssel Wasser ein. Zerkleinern Sie den Brühwürfel und verrühren Sie ihn mit Wasser. Geben Sie die restlichen Zutaten hinzu. Den Deckel schließen. Wählen Sie . Warten Sie, bis das Programm beendet ist, und servieren Sie anschließend. Sollte der Reis noch nicht gar sein, lassen Sie ihn ein paar Minuten bei geschlossenem Deckel stehen, damit er dämpfen kann.

TOMATENSUPPE MIT STÜCKEN

SUPPE ☺

1	Zwiebeln, gehackt	1	☞ Olivenöl
1	📦 Tomaten in Stücken	2	Tomaten in Stücken
1	rote Paprika, entkernt und gehackt	2	Kartoffeln
550 ml	Hühnerbrühe	1	☞ Tomatenpüree
1	☞ getrocknete Kräutermischung	1	☞ schwarzer Pfeffer

Den Deckel öffnen. Geben Sie die Brühe hinzu. Wählen Sie im Menü ☺ aus und drücken Sie ⬠. Unter Rühren zum Kochen bringen. 10 Minuten köcheln lassen. Füllen Sie die Brühe in einen Krug um. Drücken Sie ☺ zweimal, um das Programm anzuhalten. Schälen Sie die Tomaten und schneiden Sie sie in Würfel. Wählen Sie im Menü ☺ aus und drücken Sie ⬠. Geben Sie das Öl hinzu. Geben Sie die Zwiebel und die Paprika hinzu. Lassen Sie das Ganze solange kochen, bis die Zwiebeln gedünstet sind. Geben Sie die Brühe hinzu. Geben Sie die restlichen Zutaten hinzu. Den Deckel schließen. Warten Sie, bis das Programm beendet ist. Schmecken Sie das Ganze ab. Servieren Sie die Suppe mit knusprigem Brot.

CHORIZO-KOHL SUPPE MIT APFEL

SUPPE ☺

¼	Chorizo-Wurst, klein geschnitten	1	Zwiebeln, fein gehackt
1	Apfel	2	Möhren, gehackt
2	☞ Sellerie, gehackt	2	Tomaten in Stücken
¼	Weißkohl, klein geschnitten	1	☞ Tomatenpüree
2	☞ Knoblauch, geschält und gehackt	1	☞ Cayennepfeffer
1	☞ Salz	1	☞ schwarzer Pfeffer
850 ml	Gemüsebrühe		

Den Deckel öffnen. Wählen Sie im Menü ☺ aus und drücken Sie ⬠. Braten Sie die Chorizo 2 Minuten lang an. Fügen Sie die Zwiebel und den Knoblauch hinzu. Lassen Sie das Ganze solange kochen, bis die Zwiebeln gedünstet sind. Schälen, entkernen und schneiden Sie den Apfel. Geben Sie die restlichen Zutaten hinzu. Drücken Sie ☺ zweimal, um das Programm anzuhalten. Den Deckel schließen. Wählen Sie im Menü ☺ aus und drücken Sie ⬠. Warten Sie, bis das Programm beendet ist. Eine leckere Suppe, deren Geschmack sich – wenn Sie sie über Nacht im Kühlschrank stehen lassen – noch intensiver entfalten kann.

HÜHNCHEN MIT TOMATEN UND CHAMPIGNONS

FLEISCH ☺



2	Hühnerbrust, ohne Haut und Knochen	1	☞ Olivenöl
450 g	braune Champignons, geschnitten	1	📦 Tomaten in Stücken
2	☞ Knoblauch, geschält und gehackt	1	☞ Tomatensoße
1	☞ Worcestersauce	1	☞ getrockneter Oregano
	Salz und Pfeffer		

Den Deckel öffnen. Wählen Sie im Menü ☺ aus und drücken Sie ⬠. Geben Sie das Öl hinzu. Würzen Sie die Hühnerbrüste mit Salz und Pfeffer und legen Sie sie in die Schüssel. Wenden Sie das Fleisch, damit beide Seiten eine Kruste bilden können. Geben Sie den Knoblauch und die Champignons dazu. Lassen Sie alles 3 – 4 Minuten lang garen und wenden Sie das Hühnchen in dieser Zeit einmal. Geben Sie die Tomaten, Worcestersauce, Tomatensoße und Oregano hinzu. Lassen Sie das Ganze weiter garen und wenden Sie das Hühnchen ein weiteres Mal. Vergewissern Sie sich, dass das Hühnchen durch ist. Servieren Sie das Ganze mit Nudeln, Kartoffeln oder Reis. Ein leckeres Gericht, das sich schnell mit Zutaten aus Ihrem Vorratsschrank zubereiten lässt.



IN STOUTBIER GESCHMORTE RIPPCHEN MIT AHORNSIRUP UND SOJASAUCE

 FLEISCH



1 kg Rippchen aus dem Schweinebauch
350 ml Guinness / Stoutbier
140 ml Rinderbrühe / Schweinebrühe
3  Knoblauch, geschält und gehackt

1 Zwiebeln, gehackt
1  Olivenöl
60 ml Ahornsirup / Honig
2  dunkle Sojasauce









Den Deckel öffnen. Wählen Sie  im Menü. Geben Sie das Öl hinzu. Stellen Sie die Zubereitungszeit auf 1 Stunde 45 Minuten ein. Die -Taste betätigen. Geben Sie die Rippchen hinzu, braten Sie sie 5 Minuten lang an und wenden Sie sie dabei ab und zu. Nehmen Sie die Rippchen heraus. Fügen Sie die Zwiebel und den Knoblauch hinzu. Lassen Sie das Ganze solange kochen, bis die Zwiebeln gedünstet sind. Geben Sie die Rippchen wieder in die Schüssel. Rühren Sie das Guinness, die Brühe, den Ahornsirup und die Sojasauce unter. Den Deckel schließen. Warten Sie, bis das Programm beendet ist. Schmecken Sie das Gericht ab und servieren Sie das Ganze. Eignet sich ganz wunderbar als Vorspeise oder als Auswahl für verschiedene Mittagshäppchen.

RINDERBRUST-EINTOPF

1 kg Rinderbrust
2  Knoblauch, geschält und gehackt
50 g Chorizo-Wurst, in Scheiben geschnitten
2 rote Zwiebeln, gehackt
600 ml Rinderbrühe
2  getrocknete Kräutermischung
6-8 Kartoffeln (klein)
2  Worcestersauce

LANGSAMES GAREN

2  Tomatenpüree
2  Lorbeerblatt
2 Möhren
3  Sellerie
2  Rosmarin gehackt
1  Tomaten in Stücken
Salz und Pfeffer

Lassen Sie die Tomaten ungeschält. Schneiden Sie die Kartoffeln, Möhren und den Sellerie in große Stücke. Würzen Sie die Rinderbrust mit Salz und Pfeffer. Den Deckel öffnen. Wählen Sie im Menü  aus und drücken Sie . Geben Sie die Brühe hinzu. Unter Rühren zum Kochen bringen. 10 Minuten köcheln lassen. Füllen Sie die Brühe in einen Krug um. Braten Sie die Chorizo 2 Minuten lang an. Fügen Sie das Fleisch hinzu. Lassen Sie sie von allen Seiten braun anbraten. Geben Sie die Zwiebeln, Knoblauch, Kartoffeln, den Sellerie und die Möhren hinzu. Sollten Sie noch anderes Wurzelgemüse haben, das aufgebraucht werden muss, geben Sie es ebenfalls hinzu. Lassen Sie das Ganze solange kochen, bis die Zwiebeln gedünstet sind. Geben Sie die Brühe hinzu. Geben Sie die restlichen Zutaten hinzu. Drücken Sie  zweimal, um das Programm anzuhalten. Wählen Sie . Warten Sie, bis das Programm beendet ist, und servieren Sie anschließend. Es kann nicht schaden, wenn Sie das Ganze 8 Stunden lang garen lassen, aber das Essen sollte bereits nach 5 Stunden verzehrfertig sein.

Lisez les instructions, conservez-les et transférez-les si vous transférez l'appareil. Retirez tous les emballages avant utilisation.

PRÉCAUTIONS IMPORTANTES

Suivez les précautions essentielles de sécurité, à savoir:

Cet appareil peut être utilisé par des enfants âgés de 8 ans et plus et par des personnes aux aptitudes physiques, sensorielles ou mentales réduites ou ne possédant pas l'expérience et les connaissances suffisantes, pour autant que ces personnes soient supervisées/aient reçu des instructions et soient conscientes des risques encourus. Les enfants ne peuvent pas jouer avec l'appareil. Le nettoyage et l'entretien par l'utilisateur ne doivent pas être effectués par des enfants, à moins qu'ils ne soient âgés de plus de 8 ans et qu'ils soient supervisés. Tenez l'appareil et le câble hors de portée des enfants de moins de 8 ans.

Si le connecteur ou le câble est endommagé, il faut impérativement le remplacer par une pièce spéciale disponible auprès du fabricant ou de son représentant technique.

 Veillez à ne pas utiliser cet appareil à proximité de baignoires, douches, lavabos ou autres récipients contenant de l'eau.

 Une utilisation inappropriée de l'appareil peut causer des blessures.

 Les surfaces de l'appareil vont s'échauffer. La chaleur résiduelle permet de maintenir les surfaces chaudes après utilisation.

- Ne placez pas de la viande ou du poulet congelé dans l'appareil – décongelez entièrement avant d'utiliser.
- Cuisinez la viande, la volaille et les dérivés (viande hachée, hamburgers, etc.) jusqu'à ce que le jus soit clair. Cuisinez le poisson jusqu'à ce que la chair soit opaque.
- Ne tentez pas de faire cuire des aliments dans la carcasse du cuiseur – utilisez exclusivement le récipient amovible pour la cuisson.
- Ne remplissez pas au-delà de la limite **max**.
- Ne recouvrez pas l'appareil et ne posez rien dessus.
- Débranchez la prise du secteur, puis le connecteur de la prise d'alimentation de l'appareil.
- Débranchez l'appareil quand vous ne l'utilisez pas.
- N'adaptez pas d'accessoires autres que ceux fournis.
- N'utilisez pas l'appareil à d'autres fins que celles décrites dans ce mode d'emploi.
- N'utilisez pas l'appareil s'il est endommagé ou s'il ne fonctionne pas correctement.

USAGE MÉNAGER UNIQUEMENT



SCHÉMAS

- | | |
|------------------------|-----------------|
| 1. Panneau de contrôle | 5. Verre gradué |
| 2. Couvercle | 6. Panier |
| 3. Verrou du couvercle | 7. Récipient |
| 4. Couvercle intérieur | 8. Connecteur |



PRÉPARATION

1. Posez l'appareil sur une surface stable, à niveau et résistante à la chaleur.
2. N'utilisez pas l'appareil à proximité ou sous des rideaux, des étagères, des armoires ou tout autre élément susceptible d'être endommagé par la vapeur qui s'échappe.
3. Veillez à tenir à portée de main des gants de cuisine (ou un chiffon) et un set de table résistant à la chaleur ou une assiette à dîner pour déposer le récipient après la cuisson.
4. Placez le récipient à l'intérieur du cuiseur.
5. Faites pivoter le récipient d'un quart de tour dans chaque sens, pour vous assurer que le fond du récipient est bien fixé à l'appareil.



RIZ

1. Utilisez le verre gradué pour verser le riz dans le récipient.
2. N'utilisez pas plus de 10 tasses de riz.
3. Reportez-vous à l'échelle de mesure sur la gauche, à l'intérieur du récipient, qui est marquée de 2 à 10
4. Remplissez le récipient avec de l'eau jusqu'au numéro correspondant au nombre de tasses de riz utilisées.
5. Fermez le couvercle.
6. Appuyez sur le bouton . Le bouton s'allume.
7. Les segments extérieurs de l'écran vont clignoter pendant que les aliments se réchauffent.
8. L'écran affichera alors la durée de cuisson restante (13 minutes) et entamera le compte à rebours.
9. Au terme de la durée de cuisson, l'appareil va passer en mode « garder au chaud ».
10. Le voyant  s'allumera.
11. Ouvrez le couvercle.
12. Retirez le récipient et placez-le sur un set de table résistant à la chaleur ou sur une assiette de dîner.
13. Appuyez sur le bouton .
14. Utilisez la spatule pour faire tourner et mélanger le riz, de manière à ce que toute la vapeur puisse s'échapper.
15. Dans certains cas, la couche de riz en contact avec le récipient forme une croûte.
16. Si vous ne voulez pas de la croûte, vous pouvez l'enlever avec la spatule, après avoir servi le riz.





CUISSON LENTE

1. Viande rouge et légumes (voir « DORER/SAUTER/ATTENDRIR/BOUILLIR »).
2. Faites bouillir le liquide de cuisson (voir « DORER/SAUTER/ATTENDRIR/BOUILLIR »).
3. Placez les ingrédients solides dans le récipient, puis ajoutez le liquide de cuisson.
4. Fermez le couvercle.
5. Appuyez sur le bouton . Le bouton s'allume.
6. L'écran va afficher 8 heures et entamer le compte à rebours.
7. Au terme de la durée de cuisson, l'appareil va passer en mode « garder au chaud ».
8. Le voyant  s'allumera.
9. Appuyez sur le bouton . Ouvrez le couvercle. Retirez les aliments.





MIJOTAGE

1. Viande rouge et légumes (voir « DORER/SAUTER/ATTENDRIR/BOUILLIR »).
2. Faites bouillir le liquide de cuisson (voir « DORER/SAUTER/ATTENDRIR/BOUILLIR »).
3. Placez les ingrédients solides dans le récipient, puis ajoutez le liquide de cuisson.
4. Fermez le couvercle.
5. Appuyez sur le bouton . Le bouton s'allume.
6. L'écran va afficher 1 heure et entamer le compte à rebours.
7. Au terme de la durée de cuisson, l'appareil va passer en mode « garder au chaud ».
8. Le voyant  s'allumera.
9. Appuyez sur le bouton . Ouvrez le couvercle. Retirez les aliments.

VIANDE

1. Frottez toutes les faces des aliments avec l'huile de cuisson.
2. Frottez les assaisonnements éventuels sur la surface des aliments.
3. Placez une cuillère à soupe d'huile de cuisson dans le récipient.
4. Mettez les aliments dans le récipient.
5. Fermez le couvercle.
6. La durée de cuisson dépend de la taille des aliments.
7. Veillez à ne pas cuire plus de 500 g d'aliments à la fois.
8. Nous vous suggérons d'utiliser des durées de cuisson de 10 minutes + 10 minutes par 100 g de poids de boeuf.
9. Ne faites pas cuire la viande de porc ou de volaille pendant moins de 5, 10, 15, 20, 25, 30 minutes.
10. Utilisez le bouton  pour sélectionner  dans le menu.
11. Choisissez la durée de cuisson. La durée par défaut est de 20 minutes.
12. Vous pouvez uniquement utiliser les boutons h et min lorsque que la durée sur l'écran clignote.
13. Utilisez le bouton min pour naviguer dans les options (10, 15, 20, 25, 5, 10, 15, 20, 25, 30, 35, 40, 45, 50 et 55) sur l'écran
14. Si vous souhaitez que la cuisson dure 1 heure, appuyez sur le bouton h.
15. Pour annuler le réglage de 1 heure, appuyez une nouvelle fois sur le bouton h, alors que la durée sur l'écran clignote.
- Si vous n'appuyez sur aucun bouton pendant 2 minutes, l'appareil va revenir au mode de veille.
16. Lorsque vous avez réglé la durée, appuyez sur .
17. L'écran démarre le compte à rebours.
18. Au terme de la durée de cuisson, l'appareil va passer en mode « garder au chaud ».
19. Le voyant  s'allumera.
20. Appuyez sur le bouton . Ouvrez le couvercle. Retirez les aliments.

POTAGE

1. Viande rouge et légumes (voir « DORER/SAUTER/ATTENDRIR/BOUILLIR »).
2. Placez les ingrédients solides dans le récipient, puis ajoutez le liquide de cuisson.
3. Fermez le couvercle.
4. Utilisez le bouton  pour sélectionner  dans le menu.
5. Choisissez la durée de cuisson. La durée par défaut est de 1 heure.
6. Vous pouvez uniquement utiliser les boutons h et min lorsque que la durée sur l'écran clignote.
7. Utilisez le bouton min pour naviguer dans les options (10, 15, 20, 25, 5, 10, 15, 20, 25, 30, 35, 40, 45, 50 et 55) sur l'écran
8. Utilisez le bouton h pour naviguer dans les options (1, 2, 3, 4 et 5) sur l'écran
9. Pour annuler le réglage de 5 heure, appuyez une nouvelle fois sur le bouton h, alors que la durée sur l'écran clignote.
- Si vous n'appuyez sur aucun bouton pendant 2 minutes, l'appareil va revenir au mode de veille.
10. Vous avez la possibilité d'utiliser la minuterie avec ce programme (voir la section MINUTERIE).
11. Appuyez sur le bouton .
12. L'écran démarre le compte à rebours.
13. Au terme de la durée de cuisson, l'appareil va passer en mode « garder au chaud ».
14. Le voyant  s'allumera.
15. Appuyez sur le bouton . Ouvrez le couvercle. Retirez les aliments.

YAOURT

Culture de yaourt

Vous pouvez utiliser 5, 10, 15, 20, 25, 30 ml (2 cuillères à soupe) de :

- Yaourt vivant nature – il doit être frais (vérifiez que la date de péremption est assez lointaine). Différentes marques donneront des résultats différents.

Yaourt que vous avez préparé antérieurement.

- Les bactéries s'affaiblissent au fil du temps, de sorte que vous ne pouvez répéter l'opération qu'une dizaine de fois avant d'utiliser une nouvelle culture de yaourt.





Culture de yaourt lyophilisée achetée dans une pharmacie ou dans un magasin d'aliments naturels

- Si les instructions figurant sur l'emballage de la culture de yaourt diffèrent de cette notice, suivez les instructions figurant sur l'emballage.



Lait

- Vous aurez besoin d'1 litre de lait.
- Le lait entier donne un yaourt plus épais que le lait écrémé.
- Pour obtenir un yaourt encore plus épais, vous pouvez ajouter jusqu'à 8 cuillères à soupe de lait en poudre au lait liquide.
- Vous pouvez également utiliser du lait en poudre reconstitué ou du lait évaporé en conserve.



Préparation de yaourt

1. Il faut neutraliser les bactéries présentes dans le lait, afin de les empêcher de rivaliser avec les bactéries présentes dans la culture de yaourt.
2. Pendant que vous chauffez le lait, laissez la culture de yaourt atteindre la température ambiante.
3. Ouvrez le couvercle.
4. Utilisez le programme de CUISSON À LA VAPEUR (DORER/SAUTER/ATTENDRIR/BOUILLIR) pour chauffer le lait à une température immédiatement inférieure à la température d'ébullition.
5. Laissez le lait chauffer jusqu'à ce que des bulles commencent à se former sur les bords.
6. Laissez le lait refroidir jusqu'à une température allant de 37° C à 45° C.
7. Mélangez la culture de yaourt dans le lait.
8. Il faut bien mélanger le lait et la culture de yaourt, faute de quoi le yaourt pourrait être grumeleux.
9. Fermez le couvercle.
10. Utilisez le bouton  pour sélectionner  dans le menu.
11. Choisissez la durée de cuisson. La durée par défaut est de 8 heures.
12. Vous pouvez uniquement utiliser les boutons h et min lorsque que la durée sur l'écran clignote.
13. Utilisez le bouton min pour naviguer dans les options (10, 15, 20, 25, 5, 10, 15, 20, 25, 30, 35, 40, 45, 50 et 55) sur l'écran
14. Utilisez le bouton h pour naviguer dans les options (6, 7, 8, 9 et 10) sur l'écran
15. Pour annuler le réglage de 10 heure, appuyez une nouvelle fois sur le bouton h, alors que la durée sur l'écran clignote.
- Si vous n'appuyez sur aucun bouton pendant 2 minutes, l'appareil va revenir au mode de veille.
16. Vous avez la possibilité d'utiliser la minuterie avec ce programme (voir la section MINUTERIE).
17. Appuyez sur le bouton .
18. L'écran démarre le compte à rebours.
19. Au terme de la durée de cuisson, l'appareil va passer en mode de veille.
20. Il ne va pas maintenir le yaourt chaud.
21. Appuyez sur le bouton . Ouvrez le couvercle. Retirez les aliments.





PAIN

1. Décongelez totalement la pâte congelée avant utilisation.
2. Veillez à ne pas cuire plus de 500 g d'aliments à la fois.
3. Badigeonnez le récipient avec de l'huile de cuisson.
4. Placez la pâte dans le récipient.
5. Fermez le couvercle.
6. Utilisez le bouton  pour sélectionner  dans le menu.
7. Choisissez la durée de cuisson. La durée par défaut est de 3 heures.
8. Vous pouvez uniquement utiliser les boutons h et min lorsque que la durée sur l'écran clignote.
9. Utilisez le bouton min pour naviguer dans les options (10, 15, 20, 25, 5, 10, 15, 20, 25, 30, 35, 40, 45, 50 et 55) sur l'écran.
10. Utilisez le bouton h pour naviguer dans les options (1, 2, 3, 4, 5 et 6) sur l'écran.





11. Pour annuler le réglage de 6 heure, appuyez une nouvelle fois sur le bouton h, alors que la durée sur l'écran clignote.
 - Si vous n'appuyez sur aucun bouton pendant 2 minutes, l'appareil va revenir au mode de veille.
12. Vous avez la possibilité d'utiliser la minuterie avec ce programme (voir la section MINUTERIE).
13. Appuyez sur le bouton .
14. L'écran démarre le compte à rebours.
15. Au terme de la durée de cuisson, l'appareil va passer en mode « garder au chaud ».
16. Le voyant  s'allumera.
17. Appuyez sur le bouton . Ouvrez le couvercle. Retirez les aliments.



POISSON

1. Frottez toutes les faces des aliments avec l'huile de cuisson.
2. Frottez les assaisonnements éventuels sur la surface des aliments
3. Placez une cuillère à soupe d'huile de cuisson dans le récipient.
4. Mettez les aliments dans le récipient.
5. Fermez le couvercle.
6. La durée de cuisson dépend de la taille des aliments.
7. Veillez à ne pas cuire plus de 500 g d'aliments à la fois.
8. Nous vous suggérons d'utiliser des durées de cuisson de 10 minutes par 100 g de poids.
9. Utilisez le bouton  pour sélectionner  dans le menu.
10. Choisissez la durée de cuisson. La durée par défaut est de 20 minutes.
11. Vous pouvez uniquement utiliser les boutons h et min lorsque que la durée sur l'écran clignote.
12. Utilisez le bouton min pour naviguer dans les options (10, 15, 20, 25, 5, 10, 15, 20, 25, 30, 35, 40, 45, 50 et 55) sur l'écran
13. Si vous souhaitez que la cuisson dure 1 heure, appuyez sur le bouton h.
14. Pour annuler le réglage de 1 heure, appuyez une nouvelle fois sur le bouton h, alors que la durée sur l'écran clignote.
 - Si vous n'appuyez sur aucun bouton pendant 2 minutes, l'appareil va revenir au mode de veille.
15. Lorsque vous avez réglé la durée, appuyez sur .
16. L'écran démarre le compte à rebours.
17. Au terme de la durée de cuisson, l'appareil va passer en mode « garder au chaud ».
18. Le voyant  s'allumera.
19. Il est préférable de retirer les aliments dès qu'ils sont cuits, afin d'éviter qu'ils ne sèchent
20. Appuyez sur le bouton . Ouvrez le couvercle. Retirez les aliments.

CUISSON À LA VAPEUR

1. Remplissez le récipient avec de l'eau froide jusqu'au niveau portant la marque 6.
2. Placez le panier au-dessus du récipient et placez les aliments dans le panier.
3. Pour une cuisson uniforme, coupez les aliments en morceaux de taille plus ou moins identique.
4. Pour les pois ou pour les aliments qui vont se décomposer ou tomber dans l'eau, préparez un paquet avec du papier aluminium.
5. Prenez garde lors du retrait du paquet – portez les gants de cuisine et utilisez des pinces/cuillères en plastique.
6. Fermez le couvercle.
7. Utilisez le bouton  pour sélectionner  dans le menu.
8. Choisissez la durée de cuisson. La durée par défaut est de 30 minutes.
 - Les aliments doivent être cuits pendant la durée réglée par défaut :

Aliments (Frais)	Quantité
Haricots Verts	200g
Choux De Brussels	200g
Carottes (Coupées En Rondelles)	200g
Pommes De Terre (Coupées En Quatre)	400g
Brocoli	200g
Chou	Trimestre
Maïs	2

9. Vous pouvez uniquement utiliser les boutons h et min lorsque que la durée sur l'écran clignote.
10. Utilisez le bouton min pour naviguer dans les options (5, 10, 15, 20, 25, 30, 35, 40, 45, 50 et 55) sur l'écran.
11. Utilisez le bouton h pour naviguer dans les options (1 et 2) sur l'écran
12. Pour annuler le réglage de 2 heure, appuyez une nouvelle fois sur le bouton h, alors que la durée sur l'écran clignote.
 - Si vous n'appuyez sur aucun bouton pendant 2 minutes, l'appareil va revenir au mode de veille.
13. Vous avez la possibilité d'utiliser la minuterie avec ce programme (voir la section MINUTERIE).
14. Appuyez sur le bouton .
15. L'écran démarre le compte à rebours.
16. Au terme de la durée de cuisson, l'appareil va passer en mode « garder au chaud ».
17. Le voyant  s'allumera.
18. Il est préférable de retirer les aliments dès qu'ils sont cuits, afin d'éviter qu'ils ne soient détremés.
19. Appuyez sur le bouton . Ouvrez le couvercle. Retirez les aliments.

DORER/SAUTER/ATTENDRIR/BOUILLIR

- Vous pouvez utiliser le programme de CUISSON À LA VAPEUR  avec son réglage par défaut et avec le couvercle ouvert, comme cocotte à haute température pendant 5, 10, 15, 20, 25, 30 minutes, préalablement à la cuisson avec un autre programme.
- Utilisez-le avec un peu d'huile pour dorer la viande et les légumes, pour faire revenir et attendrir les oignons, le céleri, les poireaux, etc.
- Utilisez-le avec de l'eau ou du bouillon pour préchauffer les jus de cuisson.
- Lorsque vous passez au programme principal, l'appareil est chauffé et une partie ou la totalité de vos ingrédients se trouvent déjà dans le récipient.
- Cela vous évite ainsi de laver la cocotte que vous auriez utilisée pendant la préparation.



PORRIDGE/RISOTTO



Utilisez le verre gradué pour verser les céréales (riz, avoine, orge, etc.) dans le récipient.

Porridge

- Reportez-vous à l'échelle de mesure sur la droite, à l'intérieur du récipient, qui est marquée de ½ à 1½.
- Ne remplissez pas au-delà de la limite **max**.

Congee





- Reportez-vous à l'échelle de mesure située au centre, à l'intérieur du récipient, qui est marquée de 1 à 3
 - Ne remplissez pas au-delà de la limite **max**.
1. Remplissez le récipient avec de l'eau jusqu'au numéro correspondant au nombre de tasses de céréales.
 2. Fermez le couvercle.
 3. Utilisez le bouton  pour sélectionner  dans le menu.
 4. Choisissez la durée de cuisson. La durée par défaut est de 1 heure.

5. Vous pouvez uniquement utiliser les boutons h et min lorsque que la durée sur l'écran clignote.
6. Utilisez le bouton min pour naviguer dans les options (5, 10, 15, 20, 25, 30, 35, 40, 45, 50 et 55) sur l'écran
7. Utilisez le bouton h pour naviguer dans les options (1, 2, 3 et 4) sur l'écran
8. Pour annuler le réglage de 4 heure, appuyez une nouvelle fois sur le bouton h, alors que la durée sur l'écran clignote.
 - Si vous n'appuyez sur aucun bouton pendant 2 minutes, l'appareil va revenir au mode de veille.
9. Vous avez la possibilité d'utiliser la minuterie avec ce programme (voir la section MINUTERIE).
10. Appuyez sur le bouton .
11. L'écran démarre le compte à rebours.
12. Au terme de la durée de cuisson, l'appareil va passer en mode « garder au chaud ».
13. Le voyant  s'allumera.
14. Appuyez sur le bouton . Ouvrez le couvercle. Retirez les aliments.



Risotto

Suivez la recette figurant plus loin dans cette notice.









CAKE

1. Décongelez totalement la pâte congelée avant utilisation.
2. Veillez à ne pas remplir le récipient à plus de la moitié de sa capacité environ.
3. Badigeonnez le récipient avec de l'huile de cuisson.
4. Placez la pâte dans le récipient.
5. Fermez le couvercle.
6. Utilisez le bouton  pour sélectionner  dans le menu.
7. Choisissez la durée de cuisson. La durée par défaut est de 40 minutes.
8. La durée par défaut est de 40 minutes.
9. Vous pouvez uniquement utiliser les boutons h et min lorsque que la durée sur l'écran clignote.
10. Utilisez le bouton min pour naviguer dans les options (5, 10, 15, 20, 25, 30, 35, 40, 45, 50 et 55) sur l'écran
11. Utilisez le bouton h pour naviguer dans les options (1 et 2) sur l'écran
12. Pour annuler le réglage de 2 heure, appuyez une nouvelle fois sur le bouton h, alors que la durée sur l'écran clignote.
 - Si vous n'appuyez sur aucun bouton pendant 2 minutes, l'appareil va revenir au mode de veille.
13. Lorsque vous avez réglé la durée, appuyez sur .
14. L'écran démarre le compte à rebours.
15. Au terme de la durée de cuisson, l'appareil va passer en mode « garder au chaud ».
16. Le voyant  s'allumera.
17. Il est préférable de retirer les aliments dès qu'ils sont cuits, afin d'éviter qu'ils ne soient détrempés.
18. Appuyez sur le bouton . Ouvrez le couvercle. Retirez les aliments.

GARDER AU CHAUD

- Si vous souhaitez utiliser la fonction garder au chaud quand un programme ne propose pas cette fonction, lorsque le seul élément que vous voyez affiché sur l'écran est le voyant clignotant , appuyez sur le bouton .
- Appuyez sur le bouton  pour quitter cette fonction.

LA MINUTERIE

- Vous pouvez utiliser la minuterie de retardement avec les programmes de potage , yaourt , pain , cuisson à la vapeur  et porridge .
- Faites-le immédiatement après avoir réglé la durée de cuisson et avant d'appuyer sur le bouton démarrer (start)  :
 1. Appuyez sur le bouton . Le voyant  s'allumera.
 2. Choisissez l'heure à laquelle vous souhaitez que les aliments soient prêts.
 3. Par exemple, s'il est 14 h maintenant et que vous souhaitez que les aliments soient prêts à 21 h, vous devez régler l'heure sur 7 heures.

- Utilisez les boutons **h** et **min** pour régler l'heure et les minutes.
- Appuyez sur le bouton .

SOINS ET ENTRETIEN

- Débranchez l'appareil et laissez-le refroidir.
- Débranchez la prise du secteur, puis le connecteur de la prise d'alimentation de l'appareil
- Lorsque le couvercle est fermé, saisissez la partie supérieure du filtre et extrayez-la du couvercle. (FIG. A).
- Retournez le filtre pour exposer les marques sur le bord avant.
- Saisissez rapidement le couvercle du filtre et orientez le reste du filtre vers le cadenas ouvert  (FIG. B).
- Appuyez sur les onglets dans la partie inférieure du couvercle intérieur et séparez-le de l'appareil (FIG. C).
- Lavez à la main les pièces amovibles.
- Essuyez toutes les surfaces avec un tissu humide et propre.
- Aucun élément de l'appareil ne doit être lavé au lave-vaisselle.
- Remontez le filtre et remettez-le dans le couvercle.
- Remettez le couvercle intérieur dans le couvercle.

















RECYCLAGE







Afin d'éviter les problèmes occasionnés à l'environnement et à la santé par des substances dangereuses, les appareils et les batteries rechargeables et non rechargeables présentant l'un de ces symboles ne doivent pas être éliminés avec les déchets municipaux non triés. Éliminez dans tous les cas les produits électriques et électroniques et, le cas échéant, les batteries rechargeables et non rechargeables, dans un centre officiel et approprié de collecte/recyclage.

RECETTES

-  cuillère à soupe (15ml)
-  cuillère à café (5ml)
- g** grammes
- ml** millilitres
-  verre gradué
-  bâton/tige (céleri)
-  poignée
-  œuf de taille moyenne (53-63 g)

-  pincée
-  bouquet
-  herbe aromatique
-  gousse(s)
-  boîte (de conserve)
-  bocal
-  sachet (7 g)
-  œuf de grande taille (63-73 g)









CHILI AU COUSCOUS ET AUX LÉGUMES

- 1 oignon rouge, haché
- 1 grand oignon, haché
- 2  ail, pelé et haché
- 1 poivron rouge, épépiné et haché
- 1 poivron jaune, épépiné et haché
- 1 poivron orange, épépiné et haché
- 1  coriandre moulue
- 1  de purée de tomate
- 850 ml bouillon de légumes
- 2  sauce à la tomate chaude
- 120-140 ml couscous





pour servir :

- fromage râpé
- petit bouquet de de coriandre, haché

CUISSON LENTE

- 1  d'huile d'olive
- 1  haricots de Lima
- 1  haricots cannellini
- 1  piments jalapeños verts
- 1  haricots
- 1  tomates en morceaux
- 2  cumin moulu
- 1  sucre
- 2  chilli en poudre
- 2  origan séché

crème aigre

Ouvrez le couvercle. Ajouter de l'huile. Sélectionnez  sur le menu et appuyez sur le bouton . Ajouter l'oignon et l'ail. Faites cuire jusqu'à ce que les oignons soient tendres. Égouttez les haricots et ajoutez-les. Réservez le couscous. Ajoutez les ingrédients restants. Appuyez sur le bouton  deux fois pour arrêter le programme. Fermez le couvercle. Sélectionnez . Ajoutez les couscous 30 minutes avant la fin de la cuisson. Si la cuisson est déjà terminée, sélectionnez  sur le menu et faites cuire pendant environ 20 minutes de plus. Servez dans un bol avec une poignée de fromage, un filet de crème aigre et saupoudrez de coriandre fraîche. Pour un chili végétarien classique, omettez le couscous.

YAOURT FAIT MAISON

YAOURT





1200 ml lait

100 ml yogourt

option de saveur







50 g mélange de baies d'été surgelées

1  miel





Ouvrez le couvercle. Ajoutez le lait. Sélectionnez  sur le menu et appuyez sur le bouton . Laissez le lait chauffer jusqu'à ce que des bulles commencent à se former sur les bords. Appuyez sur le bouton  deux fois pour arrêter le programme. Laissez le lait refroidir jusqu'à une température allant de 37° C à 45° C. Mélangez le yaourt dans le lait. Il faut bien mélanger le lait et la culture de yaourt, faute de quoi le yaourt pourrait être grumeleux. Fermez le couvercle. Sélectionnez  sur le menu et appuyez sur le bouton . Attendez que le programme se termine. Mettez le yaourt dans le réfrigérateur pour le faire refroidir complètement. Chauffez doucement les baies dans une casserole. Ajoutez le miel. Lorsque les baies commencent à se décomposer, retirez du feu, laissez refroidir, puis mélangez avec le yaourt. Si vous souhaitez conserver votre yaourt, vous devez stériliser les bocaux que vous allez utiliser. Chauffez-les dans un four à 100° C pendant 10 minutes. Le yaourt se conserve jusqu'à 2 semaines au réfrigérateur.

CHILI AU BŒUF ÉPICÉ DE NEW YORK

RAGOÛT



450 g bœuf à braiser
 3  ail, pelé et haché
 2  cumin moulu
 1  poivre de cayenne
 1  poudre de poivron fumé/chipotle
 1 poivron vert
 1  sel
 1  feuilles de basilic, hachées grossièrement







1  d'huile d'olive
 2 oignons, hachés
 2  chilli en poudre
 2  sauce tomate
 2  tomates
 1  feuille de laurier
 1  poivre noir
 1  haricots



Ouvrez le couvercle. Ajouter de l'huile. Sélectionnez  sur le menu et appuyez sur le bouton . Hachez le bœuf, les tomates et le poivron en dés. Dorez la viande, puis retirez-la. Ajoutez les oignons, l'ail et toutes les herbes aromatiques. Faites cuire jusqu'à ce que les oignons soient tendres. Ajoutez la viande. Réservez les haricots. Ajoutez les ingrédients restants. Appuyez sur le bouton  deux fois pour arrêter le programme. Fermez le couvercle. Sélectionnez . Ajoutez les haricots 30 minutes avant la fin de la cuisson. Si la viande est encore un peu dure à la fin du programme, ajoutez une tasse d'eau et exécutez le programme de viande pendant 30 minutes supplémentaires.

TAJINE DE POISSON MAROCAIN

POISSON

2  ail, pelé et haché
 1 poivron rouge, épépiné et haché
 2 tomates en morceaux
 1  gingembre moulu
 1 bâton de cannelle
 120 ml vin blanc
 120 ml bouillon de poisson
 675 g poisson (cabillaud/aiglefin/saumon)
 1 petit bouquet de de coriandre, haché



1 oignon, haché
 2  céleri, hachée
 1  cumin moulu
 1  curcuma
 1  pâte harissa
 1  de purée de tomate
 1 citron
 1  olives vertes
 sel et poivre



Réservez la coriandre. Ouvrez le couvercle. Ajoutez les ingrédients restants. Fermez le couvercle. Sélectionnez  sur le menu et appuyez sur le bouton . Faites cuire jusqu'à ce que le poisson se décompose en lamelles (40-60 minutes). Appuyez sur le bouton  deux fois pour arrêter le programme.

Ajoutez la coriandre. Rectifiez l'assaisonnement et servez. Cette préparation se combine parfaitement avec du couscous.





SOUPE AUX POIS CASSÉS ET AU JARRET DE PORC

CUISSON LENTE 

1150 ml bouillon de poule
225 g pois cassés
1  céleri, hachée
1  thym, finement haché
1 jarret de porc



1 oignon, finement haché
1 carotte, hachée
2  ail (écrasé)
1  feuille de laurier
poivre noir







Ouvrez le couvercle. Ajoutez le bouillon. Sélectionnez  sur le menu et appuyez sur le bouton . Amener à ébullition, en mélangeant. Laisser mijoter pendant 10 minutes. Ajoutez les ingrédients restants. Appuyez sur le bouton  deux fois pour arrêter le programme. Fermez le couvercle. Sélectionnez . Attendez que le programme se termine. Retirez le jarret de porc. Jetez la peau et les os. Coupez la viande en dés. Jetez la feuille de laurier. Écrasez les pois cassés avec le dos d'une cuillère en bois. Ajouter la viande. Rectifiez l'assaisonnement et servez. Le paradis dans un bol !

SAUMON AVEC ASSAISONNEMENT ÉPICÉ

POISSON 

2 filets de saumon (avec la peau)
1  paprika
1/2  cumin moulu
1  sucre brun doux

1  d'huile d'olive
1  chilli en poudre
1  sel et poivre
1 citron

Mélangez le poivron, la poudre de piment, le cumin, le sucre, le sel et le poivre. Saupoudrez sur les filets de saumon. Ouvrez le couvercle. Ajouter de l'huile. Sélectionnez  sur le menu et appuyez sur le bouton . Attendez quelques minutes pour chauffer l'huile. Ajoutez les filets, la peau vers le bas. Fermez le couvercle. Ceci est une excellente combinaison de cuisson à la vapeur et de friture des morceaux de poisson et vous obtenez une peau croustillante. Servez avec un quartier de citron. Un excellent repas léger.

CAKE BROWNIE AU CHOCOLAT



CAKE 

170 g beurre non salé
340 g sucre
170 g poudre de cacao
110 g pépites de chocolat au lait

3  
1  essence de vanille
1  sel
75 g farine

pour servir :



crème glacée à la vanille (facultatif)





Fondre le beurre dans une poêle à feu doux. Tapissez le récipient avec du papier aluminium beurré. Fouettez le beurre fondu, le sucre, la poudre de cacao, la farine, les œufs, la vanille et le sel dans un plat. Incorporez les pépites de chocolat. Versez la pâte sur le papier aluminium dans le récipient. Fermez le couvercle. Sélectionnez  dans le menu. Réglez le temps de cuisson sur 1 heure et 30 minutes. Appuyez sur le bouton . Le gâteau doit être ferme sur les bords et légèrement crémeux en son centre. Servez le gâteau chaud, garni de crème glacée.

RAGOÛT IRLANDAIS (STEW) AVEC DES BOULETTES DE FROMAGE DE CHÈVRE

RAGOÛT 

pour le ragoût :





1.8 kg épaule d'agneau (cuite)
250 g bacon
950 ml bouillon d'agneau
1 grand oignon, haché
2  céleri, hachée
2  de purée de tomate

1  d'huile d'olive
3  ail (écrasé)
sel et poivre
2 carottes, hachées
2  romarin, haché
1  farine de maïs

pour les boulettes :

100 g	farine fermentante	1	levure en poudre
50 g	suif	1	sel
75 ml	eau	1	persil séché
40 g	fromage de chèvre (doux)	1	thym séché
1	feuilles séchées de marjolaine	1	poivre noir

pour le ragoût :

Séparez la viande de l'os. Coupez la viande et le lard en dés. Ouvrez le couvercle. Sélectionnez  sur le menu et appuyez sur le bouton . Ajoutez le bouillon. Amener à ébullition, en mélangeant. Laisser mijoter pendant 10 minutes. Versez le bouillon dans une carafe. Ajouter de l'huile. Ajouter l'oignon et faire sauter jusqu'à ce qu'il soit ramolli. Ajoutez la viande, l'ail, les herbes aromatiques et les autres légumes et faites cuire pendant 5 minutes. Ajoutez le bouillon. Ajoutez la purée de tomate. Appuyez sur le bouton  deux fois pour arrêter le programme. Fermez le couvercle. Sélectionnez .

pour les boulettes :

Mélangez tous les ingrédients à la main. Divisez le mélange en 6 boules. Laisser reposer pendant 20 minutes.



pour finir :

Formez une pâte lisse avec la farine de maïs et un peu d'eau dans une tasse. Ouvrez le couvercle 30 minutes avant la fin de la cuisson. Mélangez la pâte dans le ragoût. Ajoutez les boulettes. Fermez le couvercle. Attendez que le programme se termine, puis servez. Un plat réconfortant extraordinaire ! Si vous ne disposez pas d'agneau cuit, vous pouvez utiliser de l'agneau cru, avec le programme de cuisson lente à la place du programme de ragoût, puis continuer à partir de l'étape des boulettes.

ARTICHAUT CUIT À LA VAPEUR

VAPEUR 

1	ail, pelé et haché	2	artichauts
	bouquets d'herbes aromatiques (estragon, menthe, persil, thym)	1	citron





Coupez le citron en lamelles. Coupez la tige à la base de chaque artichaut. Coupez le quart supérieur de chaque artichaut. Jetez les feuilles abîmées. Frottez les surfaces découpées avec une tranche de citron. Placez les tranches de citron dans le panier. Ajoutez le bouquet d'herbes aromatiques. Ajoutez l'ail. Placez l'artichaut sur le dessus. Remplissez avec de l'eau jusqu'au niveau 2 de l'échelle située sur la gauche, à l'intérieur du récipient. Placez le panier sur le récipient. Fermez le couvercle. Sélectionnez  sur le menu et appuyez sur le bouton . Les artichauts sont cuits lorsque les feuilles extérieures peuvent être enlevées facilement. Servez chaud ou froid avec une vinaigrette. Incroyable !

POT-AU-FEU À BASE D'ORGE PERLÉE ET DE HARICOTS BORLOTTI RAGOÛT

1	d'huile d'olive	1	haricots Borlotti
175 g	orge perlée	1	oignon, finement haché
1	tomates en morceaux	1	de purée de tomate
1000 ml	bouillon de légumes	2	persil (haché)
125 ml	vin rouge sec		sel et poivre

pour servir :



huile pimentée (facultatif)

Ouvrez le couvercle. Sélectionnez  sur le menu et appuyez sur le bouton . Ajoutez le bouillon. Amener à ébullition, en mélangeant. Laisser mijoter pendant 10 minutes. Versez le bouillon dans une carafe. Ajouter de l'huile. Ajouter l'oignon et faire sauter jusqu'à ce qu'il soit ramolli. Ajoutez le vin et faites cuire pendant quelques minutes. Ajoutez l'orge perlée et remuez jusqu'à ce qu'il commence à prendre de la couleur du vin. Égouttez les haricots et ajoutez-les. Ajoutez les tomates. Ajoutez le bouillon. Appuyez sur le bouton  deux fois pour arrêter le programme. Fermez le couvercle. Sélectionnez . Ouvrez le couvercle 30 minutes avant la fin de la cuisson. Vérifiez la quantité de liquide dans le récipient. Ajoutez 150 ml d'eau chaude si nécessaire. Fermez le couvercle. Attendez que le programme se termine. Servez avec du pain croustillant frais et un filet d'huile pimentée.

CAKE MOELLEUX AU SIROP

VAPEUR 

115 g	beurre	2	
100 g	sucré en poudre	¼	 essence de vanille
175 g	farine fermentante	2	 lait
4	 sirop de mélasse		





Battez les œufs dans un bol. Battez le beurre et le sucre dans un récipient. Ajouter graduellement les œufs, puis la vanille et enfin la farine. Versez le lait. Graissez un plat de 1 200 ml allant au four. Versez le sirop dans le fond du plat allant au four et ensuite le mélange sur le dessus. Couvrez avec du papier sulfurisé, puis avec du papier aluminium et attachez la partie supérieure avec de la ficelle. Ouvrez le couvercle. Placez le plat allant au four à l'intérieur du récipient dans l'appareil. Ajoutez suffisamment d'eau bouillante dans le récipient dans l'appareil jusqu'à atteindre un niveau situé 3 cm en-dessous du bord supérieur du plat allant au four. Fermez le couvercle. Sélectionnez  dans le menu. Réglez le temps de cuisson sur 1 heure et 30 minutes. Appuyez sur le bouton . Attendez que le programme se termine. Retournez sur un plat et servez chaud. Un excellent dessert tout au long de l'année !!



PAIN BLANC

PAIN 



1	 sirop de mélasse	1	 beurre
320 ml	lait	1	 levure en poudre
500 g	farine forte pour pain blanc	1	 sel

Ouvrez le couvercle. Ajoutez le lait. Sélectionnez  sur le menu et appuyez sur le bouton . Laissez le lait chauffer jusqu'à ce que des bulles commencent à se former sur les bords. Versez le lait dans une carafe. Appuyez sur le bouton  deux fois pour arrêter le programme. Laissez le lait refroidir jusqu'à une température allant de 37° C à 45° C. Fondre le beurre dans une poêle à feux doux. Mélangez la farine et le sel dans un récipient. Ajoutez la levure, le beurre et le sirop. Ajoutez le lait et pétrissez jusqu'à former une boule. Si le mélange est très collant, ajoutez un peu plus de farine. Couvrez et laissez reposer dans un endroit chaud pendant 10 minutes. Pétrissez à nouveau. Couvrez et laissez reposer dans un endroit chaud pendant 10 minutes. Ouvrez le couvercle. Sélectionnez  sur le menu et appuyez sur le bouton . Fermez le couvercle. Ouvrez le couvercle 30 minutes avant la fin de la cuisson. Retournez le pain. Cela va légèrement dorer la partie supérieure du pain et lui donner une texture croustillante. Attendez que le programme se termine. Servez avec des flocons de beurre.

PAIN AU BICARBONATE DE SOUDE

PAIN 

1	 mélange pour pain au bicarbonate de soude		beurre
350 ml	eau		

Ouvrez le couvercle. Graissez le récipient avec du beurre. Sélectionnez  dans le menu. Fermez le couvercle. Réglez le temps de cuisson sur 2 heures et 15 minutes. Appuyez sur le bouton . Laissez chauffer l'appareil. Versez le mélange pour pain au bicarbonate de soude dans un récipient. Ajoutez l'eau. Mélangez à la main jusqu'à former une boule. Ouvrez le couvercle. Placez la pâte dans le récipient. Divisez la pâte en quartiers avec une spatule en plastique. Fermez le couvercle. Ouvrez le couvercle 30 minutes avant la fin de la cuisson. Retournez le pain. Cela va légèrement dorer la partie supérieure du pain et lui donner une texture croustillante. Attendez que le programme se termine. Laissez refroidir sur une grille. Servez seul avec du beurre salé ou en accompagnement d'un repas.

PORRIDGE



PORRIDGE/RISOTTO 

2	 farine d'avoine		eau
¼	 sel	2	 sucre



pour servir :

sucré brun

lait / crème fraîche

Ouvrez le couvercle. Ajoutez la farine d'avoine, le sel et le sucre. Remplissez avec de l'eau jusqu'au niveau 1½ sur l'échelle située sur la droite, à l'intérieur du récipient. Fermez le couvercle. Sélectionnez  sur le menu et appuyez sur le bouton . Attendez que le programme se termine. Servez avec du lait ou de la crème. Saupoudrez de sucre brun foncé. Si vous le souhaitez, vous pouvez ajouter des morceaux d'abricots secs ou des pruneaux coupés en deux (sans les noyaux) 15 minutes avant la fin du temps de cuisson. Le porridge non consommé peut être conservé dans le réfrigérateur pendant 2 jours, puis réchauffé.

PORRIDGE AUX NOIX

½  flocons d'avoine
120 ml lait
1  cannelle en poudre



pour servir :

sirop de mélasse

PORRIDGE/RISOTTO

eau
3  noix de coco déshydratée

amandes effilées

Ouvrez le couvercle. Ajoutez les flocons d'avoine, la cannelle, la noix de coco et le lait. Remplissez avec de l'eau jusqu'au niveau ½ sur l'échelle située sur la droite, à l'intérieur du récipient. Fermez le couvercle. Sélectionnez  sur le menu et appuyez sur le bouton . Attendez que le programme se termine. Versez du sirop de table sur le dessus et saupoudrez d'amandes effilées.



RISOTTO MULTI-CUISEUR AUX BETTERAVES

400 g betteraves
250 g riz arbori/riz pour risotto
250 ml vin blanc
900 ml bouillon de légumes / bouillon de poule





pour finir :

100 ml yogourt
1  beurre



PORRIDGE/RISOTTO



2  d'huile d'olive
1 oignon, finement haché
2  ail, pelé et haché
1  thym, finement haché

1  persil (haché)

Ouvrez le couvercle. Sélectionnez  sur le menu et appuyez sur le bouton . Ajoutez le bouillon. Amener à ébullition, en mélangeant. Laisser mijoter pendant 10 minutes. Versez le bouillon dans une carafe. Appuyez sur le bouton  deux fois pour arrêter le programme. Sélectionnez  sur le menu et appuyez sur le bouton . Laissez chauffer l'appareil. Pelez les betteraves et coupez-les en dés de 1 cm. Placez les betteraves, l'ail et l'oignon dans le récipient. Faites cuire jusqu'à ce que les oignons soient tendres. Versez le riz. Fermez le couvercle et faites cuire pendant 3-4 minutes. Ouvrez le couvercle. Versez le vin. Fermez le couvercle et faites cuire pendant 3-4 minutes. Ouvrez le couvercle. Ajoutez le thym. Ajoutez le bouillon. Fermez le couvercle. Attendez que le programme se termine. Vérifiez le riz : il doit être légèrement croquant, mais le grain ne doit pas être dur. Si le riz n'est pas tout à fait cuit, ajoutez un peu d'eau et laissez cuire quelques minutes de plus. Incorporez le beurre – c'est ce qui donne de l'éclat au risotto. Servez avec une cuillerée de yaourt et saupoudrez de persil. C'est un excellent plat comme entrée ou comme déjeuner léger.

RIZ SAVOUREUX



2  riz
1 cube de bouillon (légumes)
1 poivron rouge, épépiné et haché
1  curcuma





eau
2 carottes, hachées
2  céleri, haché
1  pois (facultatif)

RIZ



Ouvrez le couvercle. Mettez le riz dans le récipient. Remplissez avec de l'eau jusqu'au niveau 2 de l'échelle située sur la gauche, à l'intérieur du récipient. Écrasez le cube de bouillon et mélangez-le à l'eau. Ajoutez les ingrédients restants. Fermez le couvercle. Sélectionnez . Attendez que le programme se termine, puis servez. Si le riz n'est pas tout à fait cuit, laissez-le cuire pendant quelques minutes, avec le couvercle fermé, à la vapeur.





POTAGE ÉPAIS AUX TOMATES

- 1 oignon, haché
- 1  tomates en morceaux
- 1  poivron rouge, épépiné et haché
- 550 ml bouillon de poule
- 1  mélange d'herbes séchées



Ouvrez le couvercle. Ajoutez le bouillon. Sélectionnez  sur le menu et appuyez sur le bouton . Amener à ébullition, en mélangeant. Laisser mijoter pendant 10 minutes. Versez le bouillon dans une carafe. Appuyez sur le bouton  deux fois pour arrêter le programme. Pelez et coupez les pommes de terre en dés. Sélectionnez  sur le menu et appuyez sur le bouton . Ajouter de l'huile. Ajoutez l'oignon et le poivron doux. Faites cuire jusqu'à ce que les oignons soient tendres. Ajoutez le bouillon. Ajoutez les ingrédients restants. Fermez le couvercle. Attendez que le programme se termine. Rectifiez l'assaisonnement. Servez avec du pain croustillant.



SOUPE AU CHORIZO, AU CHOU ET AUX POMMES

- 1/4 chorizo, haché finement
- 1 pomme
- 2  céleri, hachée
- 1/4 chou de printemps, haché finement
- 2  ail, pelé et haché
- 1  sel
- 850 ml bouillon de légumes

Ouvrez le couvercle. Sélectionnez  sur le menu et appuyez sur le bouton . Faites revenir le chorizo pendant 2 minutes. Ajouter l'oignon et l'ail. Faites cuire jusqu'à ce que les oignons soient tendres. Pelez, épépinez et hachez la pomme. Ajoutez les ingrédients restants. Appuyez sur le bouton  deux fois pour arrêter le programme. Fermez le couvercle. Sélectionnez  sur le menu et appuyez sur le bouton . Attendez que le programme se termine. C'est un excellent potage et si vous le laissez au réfrigérateur pendant une nuit, la saveur sera encore plus prononcée.



POULET AUX TOMATES ET AUX CHAMPIGNONS

- 2 poitrines de poulet, dépouillées et désossées
- 450 g champignons bruns, hachés
- 2  ail, pelé et haché
- 1  sauce Worcestershire
- sel et poivre



Ouvrez le couvercle. Sélectionnez  sur le menu et appuyez sur le bouton . Ajouter de l'huile. Assaisonnez les poitrines de poulet avec du sel et du poivre et placez-les dans le récipient. Retournez la viande pour assaisonner les deux côtés. Ajoutez l'ail et les champignons. Faites cuire pendant 3-4 minutes, en retournant le poulet une fois. Ajoutez les tomates, la sauce Worcestershire, la sauce tomate et l'origan. Continuez la cuisson, en retournant le poulet une fois de plus. Vérifiez que le poulet est bien cuit. Servez avec des pâtes, des pommes de terre ou du riz. Un repas rapide et savoureux préparé avec les ingrédients du garde-manger.

CÔTES BRAISÉES À LA BIÈRE BRUNE (STOUT) AVEC DU SIROP D'ÉRABLE ET DU SOJA

- 1 kg côtes de poitrine de porc
- 350 ml Guinness / stout (bière brune)
- 140 ml bouillon de bœuf / bouillon de porc
- 60 ml sirop d'érable / miel



Ouvrez le couvercle. Sélectionnez  dans le menu. Ajouter de l'huile. Réglez le temps de cuisson sur 1 heure et 45 minutes. Appuyez sur le bouton . Ajoutez les côtes et dorez pendant 5 minutes, en tournant de temps à autre. Retirez les côtes. Ajouter l'oignon et l'ail. Faites cuire jusqu'à ce que les oignons soient tendres. Remettez les côtes dans le récipient. Incorporez la Guinness, le bouillon, le sirop d'érable et la sauce de soja Fermez le couvercle.

POTAGE





- 1  d'huile d'olive
- 2 tomates en morceaux
- 2 pommes de terre
- 1  de purée de tomate
- 1  poivre noir





POTAGE

- 1 oignon, finement haché
- 2 carottes, hachées
- 2 tomates en morceaux
- 1  de purée de tomate
- 1  poivre de cayenne
- 1  poivre noir

VIANDE



- 1  d'huile d'olive
- 1  tomates en morceaux
- 1  sauce tomate
- 1  origan séché

VIANDE





- 1 oignon, haché
- 1  d'huile d'olive
- 3  ail, pelé et haché
- 2  sauce de soja foncée





Attendez que le programme se termine. Rectifiez l'assaisonnement et servez. Une excellente entrée ou comme composant d'un déjeuner mixte.

POT-AU-FEU À BASE DE POITRINE DE BŒUF

1 kg	poitrine de bœuf
2 	ail, pelé et haché
50 g	chorizo, coupé en tranches
2	oignons rouges, hachés
600 ml	bouillon de bœuf
2 	mélange d'herbes séchées
6-8	pommes de terre (petites)
2 	sauce Worcestershire

CUISSON LENTE

2 	de purée de tomate
2 	feuille de laurier
2	carottes
3 	céleri
2 	romarin, haché
1 	tomates en morceaux
	sel et poivre

Laissez les peaux sur les pommes de terre. Coupez les pommes de terre, les carottes et le céleri en morceaux. Assaisonnez la poitrine de bœuf avec du sel et du poivre. Ouvrez le couvercle. Sélectionnez  sur le menu et appuyez sur le bouton . Ajoutez le bouillon. Amener à ébullition, en mélangeant. Laisser mijoter pendant 10 minutes. Versez le bouillon dans une carafe. Faites revenir le chorizo pendant 2 minutes. Ajouter la viande. Dorez sur tous les côtés. Ajoutez les oignons, l'ail, les pommes de terre, le céleri et les carottes. Si vous avez d'autres légumes-racines que vous devez consommer, ajoutez-les aussi à la préparation. Faites cuire jusqu'à ce que les oignons soient tendres. Ajoutez le bouillon. Ajoutez les ingrédients restants. Appuyez sur le bouton  deux fois pour arrêter le programme. Sélectionnez . Attendez que le programme se termine, puis servez. Vous pouvez prolonger la cuisson sans problème jusqu'à 8 heures, mais la préparation sera probablement prête à servir au bout de 5 heures.

Lees de instructies, bewaar ze goed en geef ze met het apparaat mee wanneer u deze aan een derde geeft. Verwijder alle verpakkingsmaterialen voor gebruik.

BELANGRIJKE VEILIGHEIDSMATREGELEN

Volg de gebruikelijke veiligheidsmaatregelen, zoals:

Dit apparaat kan gebruikt worden door kinderen van 8 jaar en ouder en personen met verminderde lichamelijke, zintuiglijke en verstandelijke vaardigheden of die onvoldoende ervaring of kennis hebben, indien zij onder toezicht staan of goed geïnformeerd zijn en zij de risico's begrijpen. Kinderen mogen niet met het apparaat spelen. Schoonmaak en gebruikersonderhoud mag niet door kinderen uitgevoerd worden, tenzij ze ouder dan 8 zijn en onder toezicht staan. Houd het apparaat en het snoer buiten het bereik van kinderen van jonger dan 8 jaar.

Wanneer de connector of kabel beschadigd is, moet u beide laten vervangen door een speciale set, die verkrijgbaar is bij de fabrikant of het servicebedrijf.

 Gebruik het apparaat niet in de buurt van badkuipen, douches, wastafels of andere reservoirs die water of andere vloeistoffen bevatten.

 Verkeerd gebruik van het apparaat kan leiden tot letsels.

 De oppervlakken van het apparaat zullen heet worden. De restwarmte houdt na gebruik de oppervlakken warm.

- Gebruik het apparaat niet met bevroren vlees of gevogelte; ontdooi etenswaren volledig voor gebruik.
- Rooster vlees, gevogelte en vergelijkbare producten (gehakt, hamburgers e.d.) tot het sap dat eruit loopt kleurloos is. Rooster vis totdat deze overal ondoorzichtig is.
- Probeer niets te koken in de hoofdeenheid van de koker – kook alleen in de verwijderbare schaal.
- Vul niet boven de **max.** markering.
- Houd de bovenkant van het apparaat vrij; zet er niets bovenop.
- Verwijder de stekker uit het stopcontact en verwijder dan de stekker van de stroomingang op het apparaat.
- Haal de stekker van het apparaat uit het stopcontact als hij niet wordt gebruikt.
- Gebruik alleen de bijgeleverde toebehoren of hulpstukken.
- Gebruik het apparaat niet voor andere doeleinden dan degene die in deze gebruiksaanwijzing worden beschreven.
- Gebruik het apparaat niet bij beschadigingen of storingen.

UITSLUITEND VOOR HUISHOUELIJK GEBRUIK

AFBEELDINGEN



- | | |
|------------------------|--------------|
| 1. Bedieningspaneel | 5. Maatbeker |
| 2. Deksel | 6. Mand |
| 3. Dekselvergrendeling | 7. Schaal |
| 4. Binnendeksel | 8. Connector |





VOORBEREIDING

1. Zet het apparaat op een stabiele, vlakke, hittebestendige ondergrond.
2. Gebruik het apparaat niet in nabij en onder gordijnen, planken, kastjes, of iets anders dat mogelijk beschadigd kan raken door het ontsnappende stoom.
3. Zorg ervoor dat u ovenhandschoenen (of een doek) bij de hand hebt, en een hittebestendige mat of bord om de schaal op te plaatsen na het koken.
4. Plaats de schaal in de koker.
5. Draai de schaal een kwart beide kanten op, om er zeker van te zijn dat de onderkant van de schaal goed contact heeft met het verwarmingselement.



RIJST

1. Gebruik de maatbeker om de rijst in de schaal te doen.
2. Gebruik maximaal 10 kopjes rijst.
3. Gebruik de linkse schaalverdeling van de schaal waar 2 tot en met 10 wordt aangegeven.
4. Vul de schaal met water tot de aanduiding die met het aantal kopjes rijst overeenstemt.
5. Sluit het deksel.
6. Druk op de  knop. De knop geeft licht.
7. De buitenste randen van het display knippen terwijl de etenswaren worden opgewarmd.
8. Op het display verschijnt dan de resterende kooktijd (13 minuten) en wordt er afgeteld.
9. Als de kooktijd om is, gaat het apparaat in de modus "warm houden".
10. Het  lichtje brandt.
11. Open het deksel.
12. Neem de kom uit het apparaat en plaats het op een hittebestendige mat of bord.
13. Druk op de  knop.
14. Gebruik een spatel voor het roeren en mengen van de rijst, om alle stoom te laten ontsnappen.
15. Soms zal de rijst aan de rand van de schaal een korst vormen.
16. Indien u deze korst niet wilt, kunt u het verwijderen met een spatel nadat u de rijst hebt opgediend.

SUDDEREN





1. Bruin het vlees en de groenten (zie "BRUINEN/SAUTEREN/ZACHT MAKEN/KOKEN").
2. Breng het kookvocht aan de kook (zie "BRUINEN/SAUTEREN/ZACHT MAKEN/KOKEN").
3. Doe de vaste ingrediënten in de schaal en voeg het kookvocht toe.
4. Sluit het deksel.
5. Druk op de  knop. De knop geeft licht.
6. Op het display verschijnt 8 uur en wordt er afgeteld.
7. Als de kooktijd om is, gaat het apparaat in de modus "warm houden". Het  lichtje brandt.
8. Druk op de  knop. Open het deksel. Haal het eten eruit.

STOVEN





1. Bruin het vlees en de groenten (zie "BRUINEN/SAUTEREN/ZACHT MAKEN/KOKEN").
2. Breng het kookvocht aan de kook (zie "BRUINEN/SAUTEREN/ZACHT MAKEN/KOKEN").
3. Doe de vaste ingrediënten in de schaal en voeg het kookvocht toe.
4. Sluit het deksel.
5. Druk op de  knop. De knop geeft licht.
6. Op het display wordt er afgeteld vanaf 1 uur.
7. Als de kooktijd om is, gaat het apparaat in de modus "warm houden". Het  lichtje brandt.
8. Druk op de  knop. Open het deksel. Haal het eten eruit.

VLEES

1. Smeer de etenswaren helemaal in met bakolie.
2. Smeer eventueel kruiden op de buitenzijde van de etenswaren.

3. Doe een eetlepel bakolie in de schaal.
4. Doe de etenswaren in de schaal.
5. Sluit het deksel.
6. Duur hangt af van de grootte van het voedsel.
7. Bak maximaal 500 g etenswaren per keer.
8. We raden een kooktijd van 10 minuten + 10 minuten voor elke 100 g rundvlees aan.
9. Bak varkensvlees of gevogelte minimaal 5, 10, 15, 20, 25, 30 minuten.
10. Selecteer  in het menu met de knop .
11. Kies de kooktijd. De standaardduur is 20 minuten.
12. U kunt de knoppen h en min alleen maar gebruiken wanneer de tijd op het display knippert.
13. Gebruik de knop min om de opties (10, 15, 20, 25, 5, 10, 15, 20, 25, 30, 35, 40, 45, 50 en 55) op het display weer te geven.
14. Druk op de knop h als u gedurende 1 uur wilt bakken.
15. Als u de instelling van 1 uur wilt veranderen, drukt u nogmaals op de knop h terwijl de tijd op het display knippert.
 - Als u gedurende 2 minuten niets doet, gaat het apparaat terug in stand-bymodus.
16. Druk op  wanneer u de tijd hebt ingesteld.
17. Op het display wordt er afgeteld.
18. Als de kooktijd om is, gaat het apparaat in de modus "warm houden". Het  lichtje brandt.
19. Druk op de  knop. Open het deksel. Haal het eten eruit.

SOEP

1. Bruin het vlees en de groenten (zie "BRUINEN/SAUTEREN/ZACHT MAKEN/KOKEN").
2. Doe de vaste ingrediënten in de schaal en voeg het kookvocht toe.
3. Sluit het deksel.
4. Selecteer  in het menu met de knop .
5. Kies de kooktijd. De standaardduur is 1 uur.
6. U kunt de knoppen h en min alleen maar gebruiken wanneer de tijd op het display knippert.
7. Gebruik de knop min om de opties (10, 15, 20, 25, 5, 10, 15, 20, 25, 30, 35, 40, 45, 50 en 55) op het display weer te geven.
8. Gebruik de knop h om de opties (1, 2, 3, 4 en 5) op het display weer te geven.
9. Als u de instelling van 5 uur wilt veranderen, drukt u nogmaals op de knop h terwijl de tijd op het display knippert.
 - Als u gedurende 2 minuten niets doet, gaat het apparaat terug in stand-bymodus.
10. Met dit programma kunt u de timer gebruiken (zie TIMER).
11. Druk op de  knop.
12. Op het display wordt er afgeteld.
13. Als de kooktijd om is, gaat het apparaat in de modus "warm houden". Het  lichtje brandt.
14. Druk op de  knop. Open het deksel. Haal het eten eruit.

YOGHURT

Yoghurtferment

Gebruik 5, 10, 15, 20, 25, 30 ml (2 eetlepels):

- Niet-gearomatiseerde yoghurt met levende melkzuurbacteriën - deze moet vers zijn (kies een lange houdbaarheidsdatum).

Verschillende merken geven verschillende resultaten.

- Yoghurt die u eerder hebt gemaakt.

De bacteriën verzwakken na verloop van tijd, u kunt dit daarom slechts 10 keer doen voordat u een nieuw ferment gebruikt.





Gevriesdroogd yoghurtferment van een apotheek of natuurvoedingszaak.

- Als de aanwijzingen op de verpakking iets afwijken, volg dan de aanwijzingen op de verpakking.





Melk

- U hebt 1 liter melk nodig.
- Volle melk zorgt voor een dikkere yoghurt dan magere melk.
- Om de yoghurt nog dikker te maken, kunt u tot maximaal 8 lepels poedermelk aan de melk toevoegen.
- U kunt ook kunstmatig melkpoeder of ingeblikte gecondenseerde melk gebruiken.





Yoghurt maken

1. U moet de bacteriën in de melk doden, om ervoor te zorgen dat ze niet wedijveren met de bacteriën in het yoghurtferment.
2. Wanneer u de melk opwarmt, laat het yoghurtferment dan tot kamertemperatuur opwarmen.
3. Open het deksel.
4. Gebruik het programma STOMEN (BRUINEN/SAUTEREN/ZACHT MAKEN/KOKEN) om de melk tot vlak onder het kookpunt te verwarmen.
5. Laat de melk opwarmen tot deze aan de randen begint te borrelen.
6. Laat de melk afkoelen tot tussen de 37°C en 45°C.
7. Roer het yoghurtferment door de melk.
8. Roer goed door, anders wordt de yoghurt klonterig.
9. Sluit het deksel.
10. Selecteer  in het menu met de knop .
11. Kies de kooktijd. De standaardduur is 8 uur.
12. U kunt de knoppen h en min alleen maar gebruiken wanneer de tijd op het display knippert.
13. Gebruik de knop min om de opties (10, 15, 20, 25, 5, 10, 15, 20, 25, 30, 35, 40, 45, 50 en 55) op het display weer te geven.
14. Gebruik de knop h om de opties (6, 7, 8, 9 en 10) op het display weer te geven.
15. Als u de instelling van 10 uur wilt veranderen, drukt u nogmaals op de knop h terwijl de tijd op het display knippert.
 - Als u gedurende 2 minuten niets doet, gaat het apparaat terug in stand-bymodus.
16. Met dit programma kunt u de timer gebruiken (zie TIMER).
17. Druk op de  knop.
18. Op het display wordt er afgeteld.
19. Als de kooktijd om is, gaat het apparaat in stand-bymodus.
20. De yoghurt wordt niet warm gehouden.
21. Druk op de  knop. Open het deksel. Haal het eten eruit.



BROOD

1. Laat diepgevroren deeg ontdooien alvorens deze te gebruiken.
2. Bak maximaal 500 g etenswaren per keer.
3. Wrijf de schaal in met bakolie.
4. Doe het deeg in de schaal.
5. Sluit het deksel.
6. Selecteer  in het menu met de knop .
7. Kies de kooktijd. De standaardduur is 3 uur.
8. U kunt de knoppen h en min alleen maar gebruiken wanneer de tijd op het display knippert.
9. Gebruik de knop min om de opties (10, 15, 20, 25, 5, 10, 15, 20, 25, 30, 35, 40, 45, 50 en 55) op het display weer te geven.
10. Gebruik de knop h om de opties (1, 2, 3, 4, 5 en 6) op het display weer te geven.
11. Als u de instelling van 6 uur wilt veranderen, drukt u nogmaals op de knop h terwijl de tijd op het display knippert.
 - Als u gedurende 2 minuten niets doet, gaat het apparaat terug in stand-bymodus.
12. Met dit programma kunt u de timer gebruiken (zie TIMER).
13. Druk op de  knop.
14. Op het display wordt er afgeteld.
15. Als de kooktijd om is, gaat het apparaat in de modus "warm houden". Het  lichtje brandt.
16. Druk op de  knop. Open het deksel. Haal het eten eruit.

VIS

1. Smeer de etenswaren helemaal in met bakolie.
2. Smeer eventueel kruiden op de buitenzijde van de etenswaren.
3. Doe een eetlepel bakolie in de schaal.
4. Doe de etenswaren in de schaal.
5. Sluit het deksel.
6. Duur hangt af van de grootte van het voedsel.
7. Bak maximaal 500 g etenswaren per keer.
8. We raden een kooktijd van 10 minuten voor elke 100 g vis aan.
9. Selecteer  in het menu met de knop .
10. Kies de kooktijd. De standaardduur is 20 minuten.
11. U kunt de knoppen h en min alleen maar gebruiken wanneer de tijd op het display knippert.
12. Gebruik de knop min om de opties (10, 15, 20, 25, 5, 10, 15, 20, 25, 30, 35, 40, 45, 50 en 55) op het display weer te geven.
13. Druk op de knop h als u gedurende 1 uur wilt bakken.
14. Als u de instelling van 1 uur wilt veranderen, drukt u nogmaals op de knop h terwijl de tijd op het display knippert.
 - Als u gedurende 2 minuten niets doet, gaat het apparaat terug in stand-bymodus.
15. Druk op  wanneer u de tijd hebt ingesteld.
16. Op het display wordt er afgeteld.
17. Als de kooktijd om is, gaat het apparaat in de modus "warm houden". Het  lichtje brandt.
18. Om te vermijden dat de etenswaren uitdrogen, haalt u deze best uit het apparaat wanneer ze gebakken zijn.
19. Druk op de  knop. Open het deksel. Haal het eten eruit.

STOMEN

1. Vul de schaal met koud water tot aanduiding 6.
2. Plaats de mand boven op de schaal en plaats het eten in de mand.
3. Voor eenvormig koken, moet u de stukken eten in ongeveer hetzelfde formaat snijden.
4. Voor erwten of iets anders dat breekt of in het water valt, maakt u een pakje met aluminium folie
5. Wees voorzichtig bij het verwijderen van het pakje – draag ovenhandschoenen en gebruik een plastic tang of lefels.
6. Sluit het deksel.
7. Selecteer  in het menu met de knop .
8. Kies de kooktijd. De standaardduur is 30 minuten.
 - Deze ingrediënten hebben een standaard kooktijd:

Etenswaren (vers)	Hoeveelheid
Sperziebonen	200g
Spruiten	200g
Wortel (in plakjes)	200g
Aardappelen (in vieren)	400g
Broccoli	200g
Kool	Kwartaal
Maïskolven	2

9. U kunt de knoppen h en min alleen maar gebruiken wanneer de tijd op het display knippert.
10. Gebruik de knop min om de opties (5, 10, 15, 20, 25, 30, 35, 40, 45, 50 en 55) op het display weer te geven.
11. Gebruik de knop h om de opties (1 en 2) op het display weer te geven.



12. Als u de instelling van 2 uur wilt veranderen, drukt u nogmaals op de knop h terwijl de tijd op het display knippert.
 - Als u gedurende 2 minuten niets doet, gaat het apparaat terug in stand-bymodus.
13. Met dit programma kunt u de timer gebruiken (zie TIMER).
14. Druk op de ◊ knop.
15. Op het display wordt er afgeteld.
16. Als de kooktijd om is, gaat het apparaat in de modus "warm houden". Het 🔥 lichtje brandt.
17. Om te vermijden dat de etenswaren te nat worden, haalt u deze best uit het apparaat wanneer ze gebakken zijn.
18. Druk op de ⌂ knop. Open het deksel. Haal het eten eruit.

BRUINEN/SAUTEREN/ZACHT MAKEN/KOKEN

- U kunt het programma STOMEN  in de standaardinstelling en met het deksel open gebruiken om gedurende 5, 10, 15, 20, 25, 30 minuten aan hoge temperatuur te bakken. Daarna gebruikt u een ander programma.
- Gebruik het met een beetje olie om vlees en groenten te bruinen, te sauteren, om uien, selderij, prei zacht te maken, enz.
- Gebruik het met water of bouillon om kookvocht voor te verwarmen.
- Wanneer u naar het hoofdprogramma overschakelt, wordt het apparaat opgewarmd en bevat de schaal al enkele of alle ingrediënten.
- In dat geval hoeft u de pan niet af te wassen die u tijdens de voorbereiding zou hebben gebruikt.

PORRIDGE/RISOTTO

Gebruik de maatbeker om de granen (rijst, haver, gerst, enz.) in de schaal te doen.

Porridge

- Gebruik de rechtse schaalverdeling van de schaal waar ½ tot en met 1½ wordt aangegeven.
- Vul niet boven de **max.** markering.

Congee





1. Gebruik de middelste schaalverdeling van de schaal waar 1 tot en met 3 wordt aangegeven.
2. Vul niet boven de **max.** markering.
3. Vul de schaal met water tot de aanduiding die met het aantal kopjes graan overeenstemt.
4. Sluit het deksel.
5. Selecteer  in het menu met de knop .
6. Kies de kooktijd. De standaardduur is 1 uur.
7. U kunt de knoppen h en min alleen maar gebruiken wanneer de tijd op het display knippert.
8. Gebruik de knop min om de opties (5, 10, 15, 20, 25, 30, 35, 40, 45, 50 en 55) op het display weer te geven.
9. Gebruik de knop h om de opties (1, 2, 3 en 4) op het display weer te geven.
10. Als u de instelling van 4 uur wilt veranderen, drukt u nogmaals op de knop h terwijl de tijd op het display knippert.
 - Als u gedurende 2 minuten niets doet, gaat het apparaat terug in stand-bymodus.
11. Met dit programma kunt u de timer gebruiken (zie TIMER).
12. Druk op de ◊ knop.
13. Op het display wordt er afgeteld.
14. Als de kooktijd om is, gaat het apparaat in de modus "warm houden". Het 🔥 lichtje brandt.
15. Druk op de ⌂ knop. Open het deksel. Haal het eten eruit.

Risotto



Volg het recept dat u verderop in dit boekje vindt.

CAKE









1. Laat diepgevroren deeg ontdooien alvorens deze te gebruiken.
2. Vul de schaal maximaal halfvol.

3. Wrijf de schaal in met bakolie.
4. Doe het deeg in de schaal.
5. Sluit het deksel.
6. Selecteer  in het menu met de knop .
7. Kies de kooktijd. De standaardduur is 40 minuten.
8. De standaardduur is 40 minuten.
9. U kunt de knoppen **h** en **min** alleen maar gebruiken wanneer de tijd op het display knippert.
10. Gebruik de knop **min** om de opties (5, 10, 15, 20, 25, 30, 35, 40, 45, 50 en 55) op het display weer te geven.
11. Gebruik de knop **h** om de opties (1 en 2) op het display weer te geven.
12. Als u de instelling van 2 uur wilt veranderen, drukt u nogmaals op de knop **h** terwijl de tijd op het display knippert.
 - Als u gedurende 2 minuten niets doet, gaat het apparaat terug in stand-bymodus.
13. Druk op  wanneer u de tijd hebt ingesteld.
14. Op het display wordt er afgeteld.
15. Als de kooktijd om is, gaat het apparaat in de modus "warm houden". Het  lichtje brandt.
16. Om te vermijden dat de etenswaren te nat worden, haalt u deze best uit het apparaat wanneer ze gebakken zijn.
17. Druk op de  knop. Open het deksel. Haal het eten eruit.

WARM HOUDEN

- Als u de functie warm houden wilt gebruiken na een programma dat hiervoor geen ondersteuning biedt, drukt u op  wanneer op het display enkel het lampje  knippert.
- Druk op  om deze functie te verlaten.

DE TIMER

- U kunt de vertragingstimer gebruiken met de programma's soep , yoghurt , brood , stoom  en porridge .
- Doe dit onmiddellijk na het instellen van de kooktijd en voor het drukken op start :
 1. Druk op de  knop. Het  lichtje brandt.
 2. Beslis wanneer de etenswaren klaar moeten zijn.
 3. Als het nu bijvoorbeeld 14.00 uur is en u wilt dat het eten om 21.00 uur klaar is, moet u de tijd instellen op 7uur.
 4. Gebruik de knoppen **h** en **min** om het uur en de minuten in te stellen.
 5. Druk op de  knop.

ZORG EN ONDERHOUD

1. Verwijder de stekker uit het stopcontact en laat het apparaat afkoelen.
2. Verwijder de stekker uit het stopcontact en verwijder dan de stekker van de stroomingang op het apparaat.
3. Terwijl het deksel is gesloten, neemt u de bovenkant van de filter vast en tilt u deze uit het deksel. (AFB A).
4. Draai de filter om zodat u de markeringen op de voorrand ziet.
5. Houd het filterdeksel stevig vast en draai de rest van de filter naar het geopende hangslot . (AFB B).
6. Druk op de lipjes op de onderkant van het binnendeksel en trek het uit het apparaat. (AFB C).
7. Was de afneembare onderdelen met de hand.
8. Neem alle oppervlakken af met een schone vochtige doek.
9. Plaats geen enkel onderdeel van het apparaat in de vaatwasmachine.
10. Monteer de filter opnieuw en plaats deze opnieuw in het deksel.
11. Plaats het binnendeksel opnieuw in het deksel.

RECYCLING



Om milieu- en gezondheidsproblemen door gevaarlijke stoffen te vermijden, mogen apparaten en oplaadbare en niet oplaadbare batterijen met een van deze symbolen niet samen met het huishoudelijk afval worden verwijderd. Breng elektrische en elektronische producten en, indien van toepassing, oplaadbare en niet-oplaadbare batterijen, altijd naar een officieel recycling-/inzamelpunt.

RECEPTEN

	eetlepel (15ml)
	theelepel (5ml)
g	gram
ml	milliliter
	maatbeker
	stengel (selderij)
	handvol
	ei, medium (53-63 g)

	snuifje
	bosje
	takje
	teentje(s)
	blik
	pot
	zakje (7 g)
	ei, groot (63-73 g)

PITTIG NY CHILI MET RUNDVLEES

450 g	runder braadlap
3	look, gepeld en fijngehakt
2	gemalen komijn
1	cayennepeper
1	gerookte paprika/chipotle-poeder
1	groene paprika
1	zout
1	blaadjes van basilicum, grofgemalen

1	olijfolie
2	uien, fijngehakt
2	chilipoeder
2	tomatensaus
2	tomaten
1	laurier
1	zwarte peper
1	bruine bonen

STOVEN

Open het deksel. Voeg de olie toe. Selecteer in het menu en druk op . Hak het vlees, de tomaten en de paprika in hapklare brokken. Bruin het vlees en verwijder het. Voeg de uien, de knoflook en alle kruiden toe. Bak de uien zacht. Voeg het vlees toe. Houd de bonen bij de hand. Voeg de resterende ingrediënten toe. Druk tweemaal op om het programma te stoppen. Sluit het deksel. Selecteer . Voeg 30 minuten voor het einde van de kooktijd de bonen toe. Als aan het einde van het programma het vlees nog steeds een beetje taai is, voegt u een kopje water toe en laat u het programma nog eens 30 minuten lopen.

CHILI MET GROENTEN EN COUSCOUS

1	rode ui, fijngehakt
1	grote ui, fijngehakt
2	look, gepeld en fijngehakt
1	rode paprika, zonder zaadjes en fijngehakt
1	gele paprika, zonder zaadjes en fijngehakt
1	oranje paprika, zonder zaadjes en fijngehakt
1	gemalen koriander
1	tomatenpuree
850 ml	groentebouillon
2	warme tomatensaus
120-140 ml	couscous





om te serveren:

geraspte kaas
klein bosje koriander, fijngehakt

SUDDEREN

1	olijfolie
1	boterbonen
1	cannellinibonen
1	groene jalapeños
1	bruine bonen
1	gehakte tomaten
2	gemalen komijn
1	suiker
2	chilipoeder
2	gedroogde oregano

zure room

Open het deksel. Voeg de olie toe. Selecteer  in het menu en druk op . Voeg de ui en de knoflook toe. Bak de uien zacht. Laat de bonen afdruppen en voeg deze toe. Houd de couscous bij de hand. Voeg de resterende ingrediënten toe. Druk tweemaal op  om het programma te stoppen. Sluit het deksel. Selecteer . Voeg 30 minuten voor het einde van de kooktijd de couscous toe. Als de kooktijd al om is, selecteert u  in het menu en bakt u gedurende 20 minuten verder. Serveer in een schaal met een handvol kaas, een scheut zure room en verse koriander. Voor de klassieke vegetarische chili laat u de couscous weg.

ZELGEMAAKTE YOGHURT

YOGHURT









1200 ml melk

100 ml yoghurt

met smaak

50 g mengeling van diepgevroren zomerbessen

1  honing

Open het deksel. Voeg de melk toe. Selecteer  in het menu en druk op . Laat de melk opwarmen tot deze aan de randen begint te borrelen. Druk tweemaal op  om het programma te stoppen. Laat de melk afkoelen tot tussen de 37°C en 45°C. Roer de yoghurt in de melk. Roer goed door, anders wordt de yoghurt klonterig. Sluit het deksel. Selecteer  in het menu en druk op . Wacht tot het programma is beëindigd. Laat de yoghurt volledig afkoelen in de koelkast. Verwarm de bessen voorzichtig in een pan. Voeg de honing toe. Wanneer de bessen zacht zijn, haalt u de pan van het vuur, laat u de bessen afkoelen en mengt u ze met de yoghurt. Als u de yoghurt wilt bewaren, moet u de gebruikte potten steriliseren. Verwarm deze gedurende 10 minuten in de oven op 100°C. U kunt de yoghurt tot wel 2 weken in de koelkast bewaren.

ZALM IN EEN PITTIG JASJE

VIS

2 zalmfilets (met huid)

1  olijfolie

1  paprika

1  chilipoeder

½  gemalen komijn

1  zout en peper

1  zachte bruine suiker

1 citroen

Meng de paprika, chilipoeder, komijn, suiker, zout en peper. Bestrooi over de zalmfilets. Open het deksel. Voeg de olie toe. Selecteer  in het menu en druk op . Wacht enkele minuten tot de olie is opgewarmd. Voeg de filets op de huid toe. Sluit het deksel.

Dit is een uitstekende combinatie van stomen en stukjes vis maar zo verkrijgt u een knapperige huid. Serveer met een schijfje citroen. Een uitstekende lichte maaltijd.

SOEP VAN SPLITERWTEN EN VARKENSKLUIF

SUDDEREN

1150 ml kippenbouillon

1 ui, heel fijngehakt

225 g spliterwten

1 wortel, fijngehakt

1  selderij, fijngehakt





2  knoflook (geperst)

1  tijm, heel fijngehakt

1  laurier









1 varkensklui



zwarte peper

Open het deksel. Voeg de bouillon toe. Selecteer  in het menu en druk op . Breng al roerend aan de kook. Laat 10 minuten koken. Voeg de resterende ingrediënten toe. Druk tweemaal op  om het programma te stoppen. Sluit het deksel. Selecteer . Wacht tot het programma is beëindigd. Verwijder de varkensklui. Gooi de huid en beenderen weg. Snij het vlees in stukjes. Gooi het laurierblad weg. Stamp de spliterwten fijn met een houten lepel. Voeg het vlees toe. Breng op smaak met kruiden en serveer. Hemels lekker!

MAROKKAANSE VISTAGINE

VIS 

2 	look, gepeld en fijngehakt	1	ui, fijngehakt
1	rode paprika, zonder zaadjes en fijngehakt	2 	selderij, fijngehakt
2	gehakte tomaten	1 	gemalen komijn
1 	gemalen gember	1 	kurkuma
1	kaneelstokje	1 	harissa-saus
120 ml	witte wijn	1 	tomatenpuree
120 ml	visbouillon	1	citroen
675 g	vis (kabeljauw/schelvis/zalmfilet)	1 	groene olijven
1	klein bosje koriander, fijngehakt		zout en peper

Houd de koriander bij de hand. Open het deksel. Voeg de resterende ingrediënten toe. Sluit het deksel. Selecteer  in het menu en druk op . Bak tot de vis vlokkelig is (40-60 minuten). Druk tweemaal op  om het programma te stoppen. Voeg de koriander toe. Breng op smaak met kruiden en serveer. Dit gaat geweldig samen met couscous.

IERSE STOFPOT MET BOLLETJES GEITENKAAS

STOVEN 





voor de stoofpot:

1.8 kg	lamsschouder (gebakken)	1 	olijfolie
250 g	spek	3 	knoflook (geperst)
950 ml	lamsbouillon		zout en peper
1	grote ui, fijngehakt	2	wortels, fijngehakt
2 	selderij, fijngehakt	2 	rozemarijn, fijngehakt
2 	tomatenpuree	1 	maïzena

voor de bolletjes:

100 g	zelfrijzend bakmeel	1 	bakpoeder
50 g	niervet	1 	zout
75 ml	water	1 	gedroogde peterselie
40 g	geitenkaas (zacht)	1 	gedroogde tijm
1 	gedroogde marjolein	1 	zwarte peper

voor de stoofpot:

Haal het vlees van de beenderen. Snij het vlees en de bacon in hapklare brokken. Open het deksel. Selecteer  in het menu en druk op . Voeg de bouillon toe. Breng al roerend aan de kook. Laat 10 minuten koken. Giet de bouillon in een kan. Voeg de olie toe. Voeg de ui toe en bak tot deze zacht is. Voeg het vlees, de knoflook, de kruiden en alle andere groenten toe en bak gedurende 5 minuten. Voeg de bouillon toe. Voeg de tomatenpuree toe. Druk tweemaal op  om het programma te stoppen. Sluit het deksel. Selecteer .

voor de bolletjes:

Meng alle ingrediënten met de hand. Verdeel het mengsel in 6 balletjes. Laat 20 minuten rusten.

als afwerking:

Meng in een kopje de maïzena en een beetje water tot een effen pasta. Open 30 minuten voor het einde van de kooktijd het deksel. Roer de pasta in de stoofpot. Voeg de bolletjes toe. Sluit het deksel. Wacht tot het programma is beëindigd en serveer. Een geweldig gerecht om u op te beuren!

- Als u geen gekookt lamsvlees hebt, kunt u rauw lamsvlees gebruiken met het programma voor traag bakken in plaats van het programma voor een stoofpot. Ga dan verder met de bolletjes.

CHOCOLADEBROWNIE



170 g ongezouten boter
340 g suiker
170 g cacao poeder
110 g druppels van melkchocolade

3 ⑦⑩
1 ✓ vanillearoma
1 ① zout
75 g gewone bloem

om te serveren:

vanille-ijs (optioneel)

Laat de boter in een pan zachtjes smelten. Bedek de schaal met beboterde folie. Klop de gesmolten boter, de suiker, de cacao poeder, de bloem, de eieren, de vanille en het zout in een schaal. Spatel de chocoladedruppels erdoor. Doe het beslag op de folie in de schaal. Sluit het deksel. Selecteer in het menu. Stel de kooktijd in op 1 uur en 30 minuten. Druk op de knop. De randen van de cake moeten stevig aanvoelen en het midden wat zachter. Serveer de cake warm met een bolletje ijs erop.



GESTOOMDE ARTISJOK



1 ① look, gepeld en fijnggehakt
takjes kruiden (dragon, munt, peterselie, tijm)

2 artisjokken
1 citroen

Snij de citroen in schijfjes. Snij de stengel gelijk met de onderkant van de artisjok af. Snij van elke artisjok een vierde aan de bovenkant af. Gooi beschadigde bladeren weg. Smeer de afgesneden gedeelten in met een schijfje citroen. Doe de schijfjes citroen in de mand. Voeg de takjes kruiden toe. Voeg de knoflook toe. Doe de artisjok er bovenop. Vul met water tot aanduiding 2 op de linkse schaalverdeling van de schaal. Plaats de mand op de schaal. Sluit het deksel. Selecteer in het menu en druk op . Als de buitenste bladeren veilig kunnen worden verwijderd, zijn de artisjokken gekookt. Serveer warm of koud met een vinaigrettesaus. Verbazingwekkend!

EENPANGERECHT MET PARELGERST EN BORLOTTIBONEN



1 ✓ olijfolie
175 g parelgerst
1 ① gehakte tomaten
1000 ml groentebouillon
125 ml droge rode wijn

1 ① borlottibonen
1 ui, heel fijnggehakt
1 ✓ tomatenpuree
2 ② peterselie (fijnggehakt)
zout en peper

om te serveren:

pikante chiliolie (optioneel)

Open het deksel. Selecteer in het menu en druk op . Voeg de bouillon toe. Breng al roerend aan de kook. Laat 10 minuten koken. Giet de bouillon in een kan. Voeg de olie toe. Voeg de ui toe en bak tot deze zacht is. Voeg de wijn toe en bak gedurende enkele minuten. Voeg de parelgerst toe en roer tot deze de kleur van de wijn begint aan te nemen. Laat de bonen afdruppen en voeg deze toe. Voeg de tomaten toe. Voeg de bouillon toe. Druk tweemaal op om het programma te stoppen. Sluit het deksel. Selecteer . Open 30 minuten voor het einde van de kooktijd het deksel. Controleer de hoeveelheid vloeistof in de schaal. Voeg indien nodig 150 ml heet water toe. Sluit het deksel. Wacht tot het programma is beëindigd. Serveer met vers, knapperig brood en een beetje pikante chiliolie.

LICHTE CAKE MET STROOP



115 g boter
100 g rietsuiker
175 g zelfrijzend bakmeel
4 ✓ melassestroop

2 ⑥⑩
¼ ✓ vanillearoma
2 ✓ melk





Klop de eieren los in een schaal. Klop de boter en de suiker in een schaal op. Voeg langzaam de eieren, de vanille en de bloem toe. Roer de melk erin. Vet een ovenschaal van 1200 ml in. Giet de stroop op de onderkant van de ovenschaal en doe het mengsel erop. Bedek met bakpapier en vervolgens met folie. Maak dan de bovenkant vast met een koord. Open het deksel. Plaats de ovenschaal in de schaal van het apparaat. Giet genoeg kokend water in de schaal van het apparaat om deze tot op 3 cm van de bovenkant van de ovenschotel te vullen. Sluit het deksel. Selecteer in het menu. Stel de kooktijd in op 1 uur en 30 minuten. Druk op de knop. Wacht tot het programma is beëindigd. Draai ondersteboven op een schotel en serveer warm. Dit is een geweldige pudding voor alle tijden van het jaar!

WIT BROOD

BROOD

1  melassestroop
320 ml melk
500 g bloem voor witbrood

1  boter
1  gedroogde gist
1  zout

Open het deksel. Voeg de melk toe. Selecteer  in het menu en druk op . Laat de melk opwarmen tot deze aan de randen begint te borrelen. Giet de melk in een kan. Druk tweemaal op  om het programma te stoppen. Laat de melk afkoelen tot tussen de 37°C en 45°C. Laat de boter in een pan zachtjes smelten. Meng de bloem en het zout in een schaal. Voeg de gist, het boter en de stroop toe. Voeg de melk toe en kneed in een bol. Als het mengsel erg plakkerig is, voegt u een beetje extra bloem toe. Dek af en laat het gedurende 10 minuten rusten in een warme plaats. Kneed nogmaals. Dek af en laat het gedurende 10 minuten rusten in een warme plaats. Open het deksel. Selecteer  in het menu en druk op . Sluit het deksel. Open 30 minuten voor het einde van de kooktijd het deksel. Draai het brood om. Hierdoor krijgt de bovenkant van het brood een beetje kleur en een korst. Wacht tot het programma is beëindigd. Serveer met boter.

SODABROOD

BROOD



1  mengsel voor sodabrood
350 ml water

boter

Open het deksel. Vet de schaal met boter in. Selecteer  in het menu. Sluit het deksel. Stel de kooktijd in op 2 uur en 15 minuten. Druk op de  knop. Laat het opwarmen. Doe het mengsel voor sodabrood in een schaal. Voeg het water toe. Meng met de hand en vorm een bal. Open het deksel. Doe het deeg in de schaal. Verdeel het deeg in vier delen met een plastic spatel. Sluit het deksel. Open 30 minuten voor het einde van de kooktijd het deksel. Draai het brood om. Hierdoor krijgt de bovenkant van het brood een beetje kleur en een korst. Wacht tot het programma is beëindigd. Laar afkoelen op een rooster. Serveer alleen met gezouten boter of bij een gerecht.

PORRIDGE

PORRIDGE/RISOTTO



2  havermout
1  zout

water
2  suiker

om te serveren:



donkerbruine suiker

melk / enkele

Open het deksel. Voeg de havermeel, het zout en de suiker toe. Vul met water tot aanduiding 1½ op de rechtse schaalverdeling van de schaal. Sluit het deksel. Selecteer  in het menu en druk op . Wacht tot het programma is beëindigd. Serveer met melk of room. Bestrooi met donkerbruine suiker. Indien gewenst kunt u 15 minuten voor het einde van de kooktijd fijngehakte, gedroogde abrikozen of halve pruimen (zonder pit) toevoegen. Als er porridge over is, kunt u deze in de koelkast gedurende maximaal 2 dagen bewaren. U moet het gerecht dan opnieuw opwarmen.

PORRIDGE MET NOTEN

PORRIDGE/RISOTTO

½  havervlokken
120 ml melk
1  gemalen kaneel

water
3  gedroogde kokosnoot

om te serveren:

melassestroop

amandelstukjes

Open het deksel. Voeg de haver, de kaneel, de kokosnoot en de melk toe. Vul met water tot aanduiding 1½ op de rechtse schaalverdeling van de schaal. Sluit het deksel. Selecteer  in het menu en druk op . Wacht tot het programma is beëindigd. Besprenkel met melassestroop en bestrooi met amandelstukjes.

RISOTTO MET RODE BIET IN MULTI-COOKER

PORRIDGE/RISOTTO





400 g rode biet
250 g arbori/risottorijst
250 ml witte wijn
900 ml groentebouillon / kippenbouillon

2  olijfolie
1 ui, heel fijngehakt
2  look, gepeld en fijngehakt
1  tijm, heel fijngehakt

als afwerking:

100 ml yoghurt
1 boter

1 peterselie (fijngehakt)

Open het deksel. Selecteer  in het menu en druk op . Voeg de bouillon toe. Breng al roerend aan de kook. Laat 10 minuten koken. Giet de bouillon in een kan. Druk tweemaal op  om het programma te stoppen. Selecteer  in het menu en druk op . Laat het opwarmen. Pel de rode biet en snij deze in blokjes van 1 cm. Doe de rode biet, de knoflook en de ui in de schaal. Bak de uien zacht. Roer de rijst erin. Sluit het deksel en bak gedurende 3 tot 4 minuten. Open het deksel. Roer de wijn erin. Sluit het deksel en bak gedurende 3 tot 4 minuten. Open het deksel. Voeg de tijm toe. Voeg de bouillon toe. Sluit het deksel. Wacht tot het programma is beëindigd. Controleer de rijst. Deze moet zachtgekookt zijn en niet hard. Als de rijst niet klaar is, voegt u een beetje water toe en laat u nog enkele minuten koken. Roer de boter erin. Hierdoor krijgt de risotto een glans. Serveer met een klein beetje yoghurt en bestrooi met peterselie Dit is een geweldige voorgerecht of een lichte maaltijd.



GEURIGE RIJST

RIJST

2 rijst
1 dobbelsteentje (groente)
1 rode paprika, zonder zaadjes en fijngehakt
1 kurkuma

water
2 wortels, fijngehakt
2 selderij, fijngehakt
1 erwten (optioneel)





Open het deksel. Doe de rijst in de schaal. Vul met water tot aanduiding 2 op de linkse schaalverdeling van de schaal. Verbrijzel het bouillonblokje en roer het in het water. Voeg de resterende ingrediënten toe. Sluit het deksel. Selecteer . Wacht tot het programma is beëindigd en serveer. Als de rijst nog niet klaar is, laat u deze gedurende enkele minuten stomen met het deksel gesloten.

TOMATENSOEP MET STUKKEN

SOEP

1 ui, fijngehakt
1 gehakte tomaten
1 rode paprika, zonder zaadjes en fijngehakt
550 ml kippenbouillon
1 gedroogde kruidenmengsel

1 olijfolie
2 gehakte tomaten
2 aardappel
1 tomatenpuree
1 zwarte peper

Open het deksel. Voeg de bouillon toe. Selecteer  in het menu en druk op . Breng al roerend aan de kook. Laat 10 minuten koken. Giet de bouillon in een kan. Druk tweemaal op  om het programma te stoppen. Schil de aardappelen en snij ze in blokjes. Selecteer  in het menu en druk op . Voeg de olie toe. Voeg de ui en de paprika toe. Bak de uien zacht. Voeg de bouillon toe. Voeg de resterende ingrediënten toe. Sluit het deksel.





Wacht tot het programma is beëindigd. Breng op smaak met kruiden. Serveer met knapperig brood.

SOEP VAN CHORIZO, KOOL EN APPEL

SOEP







1/4 chorizo, heel fijngehakt
1 appel
2 selderij, fijngehakt
1/4 savooiekool, heel fijngehakt
2 look, gepeld en fijngehakt
1 zout
850 ml groentebouillon



1 ui, heel fijngehakt
2 wortels, fijngehakt
2 gehakte tomaten
1 tomatenpuree
1 cayennepeper
1 zwarte peper

Open het deksel. Selecteer  in het menu en druk op . Sauteer de chorizo gedurende 2 minuten. Voeg de ui en de knoflook toe. Bak de uien zacht. Schil de appel, verwijder het klokhuis en snij de appel fijn. Voeg de resterende ingrediënten toe. Druk tweemaal op  om het programma te stoppen. Sluit het deksel. Selecteer  in het menu en druk op . Wacht tot het programma is beëindigd. Dit is een geweldige soep en als u deze een nachtje in de koelkast laat, dringen de smaken nog verder door.

KIP MET TOMATEN EN CHAMPIGNONS



VLEES 



2	kipfilet	1 	olijfolie
450 g	bruine champignons, fijngehakt	1 	gehakte tomaten
2 	look, gepeld en fijngehakt	1 	tomatensaus
1 	Worcestershire saus	1 	gedroogde oregano
	zout en peper		

Open het deksel. Selecteer  in het menu en druk op . Voeg de olie toe. Breng de kippenborst op smaak met zout en peper en doe deze in de schaal. Draai het vlees om beide kanten dicht te schroeien. Voeg de knoflook en de champignons toe. Bak gedurende 3 tot 4 minuten en draai tijdens deze periode de kip eenmaal om. Voeg de tomaten, de Worcestersaus, de tomatensaus en de oregano toe. Bak verder en draai de kip nogmaals. Controleer of de kip gaar is. Serveer met pasta, aardappelen of rijst. Een snel en smakelijk gemakkelijk te bewaren gerecht.

RIBSTUK IN STOUT MET MAPLESIROOP EN SOJASAU









VLEES 





1 kg	varkensribbetjes	1	ui, fijngehakt
350 ml	Guinness / stout	1 	olijfolie
140 ml	runderbouillon / varkensbouillon	3 	look, gepeld en fijngehakt
60 ml	maplesiroop / honing	2 	donkere sojasaus

Open het deksel. Selecteer  in het menu. Voeg de olie toe. Stel de kooktijd in op 1 uur en 45 minuten. Druk op de  knop. Voeg de ribbetjes toe en bruin gedurende 5 minuten. Draai tijdens deze periode het vlees af en toe. Verwijder de ribbetjes. Voeg de ui en de knoflook toe. Bak de uien zacht. Doe de ribbetjes opnieuw in de schaal. Roer de Guinness, de bouillon, de maplesiroop en de sojasaus erin. Sluit het deksel. Wacht tot het programma is beëindigd. Breng op smaak met kruiden en serveer. Een geweldig voorgerecht of als deel van een gevarieerde maaltijd.

EENPANSGERECHT MET BORSTSTUK

SUDDEREN 

1 kg	borststuk	2 	tomatenpuree
2 	look, gepeld en fijngehakt	2 	laurier
50 g	chorizo, in plakjes gesneden	2	wortels
2	rode uien, fijngehakt	3 	selderij
600 ml	runderbouillon	2 	rozemarijn, fijngehakt
2 	gedroogde kruidenmengsel	1 	gehakte tomaten
6-8	aardappelen (klein)		zout en peper
2 	Worcestershire saus		

Schil de aardappelen niet. Snij de aardappelen, de wortels en de selderij in stukjes. Breng het borststuk op smaak met zout en peper. Open het deksel. Selecteer  in het menu en druk op . Voeg de bouillon toe. Breng al roerend aan de kook. Laat 10 minuten koken. Giet de bouillon in een kan. Sauteer de chorizo gedurende 2 minuten. Voeg het vlees toe. Laat het stuk overal bruen. Voeg de uien, de knoflook, de aardappelen, de selderij en de wortels toe. Als u andere wortelgewassen hebt die moeten worden opgebruikt, voegt u deze ook toe. Bak de uien zacht. Voeg de bouillon toe. Voeg de resterende ingrediënten toe. Druk tweemaal op  om het programma te stoppen. Selecteer . Wacht tot het programma is beëindigd en serveer. U kunt het gerecht gedurende 8 uur laten bakken maar 5 uur zal wellicht voldoende zijn.

Leggere le istruzioni e conservarle al sicuro. In caso di cessione dell'apparecchio ad altre persone, consegnare anche le istruzioni. Rimuovere tutto l'imballaggio prima dell'uso.

NORME DI SICUREZZA IMPORTANTI

Osservare le precauzioni fondamentali di sicurezza e in particolare quanto segue:

L'apparecchio può essere utilizzato da bambini di almeno 8 anni e da persone con ridotte capacità fisiche, sensoriali o mentali o senza esperienza e conoscenza a condizione che vengano controllate/istruite e capiscano i pericoli in cui si può incorrere. I bambini non devono giocare con l'apparecchio. La pulizia e la manutenzione da parte dell'utente non devono essere effettuate da bambini di età inferiore agli 8 anni e sotto il controllo di un adulto. Tenere l'apparecchio e il cavo fuori dalla portata dei bambini di età inferiore agli 8 anni.

Se il connettore o il cavo sono danneggiati, devono essere sostituiti con uno speciale assieme disponibile dal produttore o dal suo responsabile dell'assistenza.

 Non utilizzare l'apparecchio vicino a vasche da bagno, docce, lavandini o altri recipienti contenenti acqua.

 L'uso errato dell'apparecchio può causare lesioni.

 Le superfici dell'apparecchio diventeranno calde. Il calore residuo mantiene le superfici calde dopo l'uso.

- Non mettere nell'apparecchio carne o pollame congelato; scongelarli bene prima di usarla.
- Cuocere la carne, il pollame e derivati (carne macinata, hamburger, ecc.) fino a quando i liquidi che fuoriescono sono trasparenti. Cuocere il pesce fino a quando è completamente opaco all'interno.
- Non cercare di cuocere niente nel corpo della cooker - cuocere solo nella ciotola rimovibile.
- Non riempire oltre l'indicatore di livello **max**.
- Non coprire l'apparecchio, e non metterci sopra niente.
- Togliere la spina dalla presa di corrente, quindi rimuovere il connettore dalla presa d'alimentazione dell'apparecchio.
- Staccare la spina dalla presa di corrente quando non state utilizzando l'apparecchio.
- Montare sull'apparecchio solo gli accessori o gli elementi dati in dotazione.
- Non usare l'apparecchio per altri scopi se non quelli per i quali è stato progettato, di seguito descritti in questo manuale di istruzioni.
- Non usare l'apparecchio se è danneggiato o funziona male.

SOLO PER USO DOMESTICO

IMMAGINI



- | | |
|--------------------------|---------------|
| 1. Pannello di controllo | 5. Misurino |
| 2. Coperchio | 6. Cestello |
| 3. Blocco del coperchio | 7. Ciotola |
| 4. Coperchio interno | 8. Connettore |





PREPARAZIONE

1. Posizionare l'apparecchio su una superficie stabile, in piano e resistente al calore.
2. Non usare l'apparecchio vicino o sotto tende, scaffali, credenze o simili per evitare di danneggiarli con il vapore che fuoriesce.
3. Tenere dei guanti da forno (o uno strofinaccio) a portata di mano e un sottopentola resistente al calore o un piatto di portata per poggiare la ciotola dopo la cottura.
4. Inserire la ciotola all'interno della cooker.
5. Dare alla ciotola un quarto di giro in ogni direzione per assicurarsi che la parte inferiore della ciotola sia bene in contatto con l'elemento.



RISO

1. Utilizzare il misurino per mettere il riso nella ciotola.
2. Non utilizzare più di 10 misurini di riso.
3. Utilizzare la scala a sinistra, all'interno della ciotola, che va da 2 a 10
4. Riempire la ciotola con acqua fino al valore corrispondente al numero di misurini di riso utilizzati.
5. Chiudere il coperchio.
6. Premere il pulsante . Il pulsante si illuminerà.
7. I segmenti esterni del display lampeggeranno mentre il cibo si scalda.
8. A questo punto il display indicherà il tempo di cottura rimanente (13 minuti) e inizierà il conto alla rovescia.
9. Alla fine del tempo di cottura, l'apparecchio entrerà in modalità "mantenere caldo".
10. La spia  si illuminerà.
11. Aprire il coperchio.
12. Sollevare la ciotola e posizionarla su un sottopentola resistente al calore o su un piatto di portata.
13. Premere il pulsante .
14. Usare la spatola per mescolare il riso per lasciare fuoriuscire tutto il vapore.
15. A volte sullo strato di riso a contatto con la ciotola può formarsi una crosta.
16. Se non volete che si formi, potete rimuoverla con la spatola, dopo aver servito il riso.





COTTURA LENTA

1. Carne imbiandita e verdure (vedi "IMBIONDIRE/ROSOLARE/AMMORBIDIRE/BOLLIRE").
2. Bollire il liquido di cottura (vedi "IMBIONDIRE/ROSOLARE/AMMORBIDIRE/BOLLIRE").
3. Mettere gli ingredienti solidi nella ciotola, quindi aggiungere il liquido di cottura.
4. Chiudere il coperchio.
5. Premere il pulsante . Il pulsante si illuminerà.
6. Il display indicherà 8 ore e inizierà il conto alla rovescia.
7. Alla fine del tempo di cottura, l'apparecchio entrerà in modalità "mantenere caldo".
8. La spia  si illuminerà.
9. Premere il pulsante . Aprire il coperchio. Togliere il cibo.

STUFATURA





1. Carne imbiandita e verdure (vedi "IMBIONDIRE/ROSOLARE/AMMORBIDIRE/BOLLIRE").
2. Bollire il liquido di cottura (vedi "IMBIONDIRE/ROSOLARE/AMMORBIDIRE/BOLLIRE").
3. Mettere gli ingredienti solidi nella ciotola, quindi aggiungere il liquido di cottura.
4. Chiudere il coperchio.
5. Premere il pulsante . Il pulsante si illuminerà.
6. Il display indicherà 1 ora e inizierà il conto alla rovescia.
7. Alla fine del tempo di cottura, l'apparecchio entrerà in modalità "mantenere caldo".
8. La spia  si illuminerà.
9. Premere il pulsante . Aprire il coperchio. Togliere il cibo.

CARNE

1. Passare il cibo nell'olio da cucina.
2. Distribuire qualsiasi condimento sulla superficie del cibo.
3. Mettere un cucchiaino di olio da cucina nella ciotola.
4. Mettere il cibo nella ciotola.
5. Chiudere il coperchio.
6. Il tempo di cottura dipende dalle dimensioni del cibo.
7. Non cuocere più di 500g di cibo alla volta.
8. Consigliamo tempi di cottura di 10 minuti + 10 minuti per 100g di peso per la carne di manzo.
9. Non cuocere la carne di maiale o il pollame per meno di 5, 10, 15, 20, 25, 30 minuti.
10. Utilizzare il pulsante  per selezionare  nel menu.
11. Scegliere il tempo di cottura. Il tempo predefinito è impostato a 20 minuti.
12. E' possibile utilizzare solo i pulsanti h e min mentre il tempo sul display lampeggia.
13. Utilizzare il pulsante min per spostare il display sulle varie opzioni (10, 15, 20, 25, 5, 10, 15, 20, 25, 30, 35, 40, 45, 50 e 55).
14. Se si desidera cucinare per 1 ora, premere il pulsante h.
15. Per togliere l'impostazione di 1 ora, premere di nuovo il pulsante h, mentre il tempo sul display sta lampeggiando.
 - Se non si preme alcun pulsante per 2 minuti, l'apparecchio ritorna alla modalità di standby.
16. Una volta impostato il tempo, premere .
17. Il display inizierà il conto alla rovescia.
18. Alla fine del tempo di cottura, l'apparecchio entrerà in modalità "mantenere caldo".
19. La spia  si illuminerà.
20. Premere il pulsante . Aprire il coperchio. Togliere il cibo.



MINESTRA

1. Carne imbiandita e verdure (vedi "IMBIONDIRE/ROSOLARE/AMMORBIDIRE/BOLLIRE").
2. Mettere gli ingredienti solidi nella ciotola, quindi aggiungere il liquido di cottura.
3. Chiudere il coperchio.
4. Utilizzare il pulsante  per selezionare  nel menu.
5. Scegliere il tempo di cottura. Il tempo predefinito è di 1 ora.
6. E' possibile utilizzare solo i pulsanti h e min mentre il tempo sul display lampeggia.
7. Utilizzare il pulsante min per spostare il display sulle varie opzioni (10, 15, 20, 25, 5, 10, 15, 20, 25, 30, 35, 40, 45, 50 e 55).
8. Utilizzare il pulsante h per spostare il display sulle varie opzioni (1, 2, 3, 4 e 5).
9. Per togliere l'impostazione di 5 ore, premere di nuovo il pulsante h, mentre il tempo sul display sta lampeggiando.
 - Se non si preme alcun pulsante per 2 minuti, l'apparecchio ritorna alla modalità di standby.
10. E' possibile utilizzare l'opzione del timer con questo programma (vedi TIMER).
11. Premere il pulsante .
12. Il display inizierà il conto alla rovescia.
13. Alla fine del tempo di cottura, l'apparecchio entrerà in modalità "mantenere caldo".
14. La spia  si illuminerà.
15. Premere il pulsante . Aprire il coperchio. Togliere il cibo.

YOGURT

Coltura di yogurt

Potete utilizzare 5, 10, 15, 20, 25, 30ml (2 cucchiaini da tavola) di:

- Yogurt vivo senza aromi – deve essere fresco (cercare una data di scadenza lunga).
- Marche differenti daranno risultati differenti.

Yogurt che avete preparato precedentemente.

- I batteri si indeboliscono nel tempo, perciò potete prepararlo solo 10 volte prima di passare ad una coltura nuova.





Coltura di yogurt liofilizzato in farmacia o in un negozio di prodotti dietetici.

- Se le istruzioni sulla confezione della coltura sono diverse da quelle di questo manuale, seguire le istruzioni sulla confezione.



Latte



- Avrete bisogno di 1 litro di latte.
- Il latte intero dà vita ad uno yogurt più denso rispetto al latte scremato.
- Per renderlo ancora più denso, potete aggiungere fino a 8 cucchiari di latte in polvere al latte liquido.
- Potete usare anche del latte in polvere ricostituito, o latte condensato in scatola.

Preparazione dello yogurt





1. Bisognerà uccidere i batteri del latte per evitare che entrino in competizione con i batteri della coltura di yogurt.
2. Mentre scaldate il latte, lasciate che la coltura di yogurt raggiunga la temperatura ambiente.
3. Aprire il coperchio.
4. Utilizzare il programma VAPORE (IMBIONDIRE/ROSOLARE/AMMORBIDIRE/BOLLIRE) per scaldare il latte fino a poco prima dell'ebollizione.
5. Fare scaldare il latte finché cominceranno a formarsi delle bolle ai bordi.
6. Lasciare raffreddare il latte tra i 37°C e i 45°C.
7. Mescolare la coltura di yogurt nel latte.
8. Le parti devono essere mescolate bene, altrimenti lo yogurt sarà grumoso.
9. Chiudere il coperchio.
10. Utilizzare il pulsante  per selezionare  nel menu.
11. Scegliere il tempo di cottura. Il tempo predefinito è di 8 ore.
12. E' possibile utilizzare solo i pulsanti h e min mentre il tempo sul display lampeggia.
13. Utilizzare il pulsante min per spostare il display sulle varie opzioni (10, 15, 20, 25, 5, 10, 15, 20, 25, 30, 35, 40, 45, 50 e 55).
14. Utilizzare il pulsante h per spostare il display sulle varie opzioni (6, 7, 8, 9 e 10).
15. Per togliere l'impostazione di 10 ora, premere di nuovo il pulsante h, mentre il tempo sul display sta lampeggiando.
- Se non si preme alcun pulsante per 2 minuti, l'apparecchio ritorna alla modalità di standby.
16. E' possibile utilizzare l'opzione del timer con questo programma (vedi TIMER).
17. Premere il pulsante .
18. Il display inizierà il conto alla rovescia.
19. Alla fine del tempo di cottura, l'apparecchio entrerà in modalità standby.
20. Lo yogurt non sarà mantenuto al caldo.
21. Premere il pulsante . Aprire il coperchio. Togliere il cibo.

PANE



1. Scongelare completamente l'impasto congelato prima dell'uso.
2. Non cuocere più di 500g di cibo alla volta.
3. Passare dell'olio da cucina nella ciotola.
4. Mettere l'impasto nella ciotola.
5. Chiudere il coperchio.
6. Utilizzare il pulsante  per selezionare  nel menu.
7. Scegliere il tempo di cottura. Il tempo predefinito è di 3 ore.
8. E' possibile utilizzare solo i pulsanti h e min mentre il tempo sul display lampeggia.
9. Utilizzare il pulsante min per spostare il display sulle varie opzioni (10, 15, 20, 25, 5, 10, 15, 20, 25, 30, 35, 40, 45, 50 e 55).
10. Utilizzare il pulsante h per spostare il display sulle varie opzioni (1, 2, 3, 4, 5 e 6).
11. Per togliere l'impostazione di 6 ora, premere di nuovo il pulsante h, mentre il tempo sul display sta lampeggiando.

- Se non si preme alcun pulsante per 2 minuti, l'apparecchio ritorna alla modalità di standby.
- 12. E' possibile utilizzare l'opzione del timer con questo programma (vedi TIMER).
- 13. Premere il pulsante .
- 14. Il display inizierà il conto alla rovescia.
- 15. Alla fine del tempo di cottura, l'apparecchio entrerà in modalità "mantenere caldo".
- 16. La spia  si illuminerà.
- 17. Premere il pulsante . Aprire il coperchio. Togliere il cibo.

PESCE



1. Passare il cibo nell'olio da cucina.
 2. Distribuire qualsiasi condimento sulla superficie del cibo.
 3. Mettere un cucchiaino di olio da cucina nella ciotola.
 4. Mettere il cibo nella ciotola.
 5. Chiudere il coperchio.
 6. Il tempo di cottura dipende dalle dimensioni del cibo.
 7. Non cuocere più di 500g di cibo alla volta.
 8. Consigliamo tempi di cottura di 10 minuti per 100g di peso.
 9. Utilizzare il pulsante  per selezionare  nel menu.
 10. Scegliere il tempo di cottura. Il tempo predefinito è impostato a 20 minuti.
 11. E' possibile utilizzare solo i pulsanti h e min mentre il tempo sul display lampeggia.
 12. Utilizzare il pulsante min per spostare il display sulle varie opzioni (10, 15, 20, 25, 5, 10, 15, 20, 25, 30, 35, 40, 45, 50 e 55).
 13. Se si desidera cucinare per 1 ora, premere il pulsante h.
 14. Per togliere l'impostazione di 1 ora, premere di nuovo il pulsante h, mentre il tempo sul display sta lampeggiando.
- Se non si preme alcun pulsante per 2 minuti, l'apparecchio ritorna alla modalità di standby.
 - 15. Una volta impostato il tempo, premere .
 - 16. Il display inizierà il conto alla rovescia.
 - 17. Alla fine del tempo di cottura, l'apparecchio entrerà in modalità "mantenere caldo".
 - 18. La spia  si illuminerà.
 - 19. È meglio rimuovere il cibo non appena cotto, per impedire che si asciughi.
 - 20. Premere il pulsante . Aprire il coperchio. Togliere il cibo.

COTTURA A VAPORE

1. Riempire la ciotola con acqua fredda fino al segno 6.
 2. Posizionare il cestello sulla ciotola e mettere il cibo nel cestello.
 3. Per ottenere una cottura uniforme, tagliare tutti i pezzi di cibo più o meno delle stesse dimensioni.
 4. Se si usano i piselli, o altro cibo che può sfaldarsi o cadere nell'acqua, avvolgere in carta di alluminio.
 5. Rimuovere la carta di alluminio con cura - indossare guanti da forno e usare pinze/cucchiai in plastica.
 6. Chiudere il coperchio.
 7. Utilizzare il pulsante  per selezionare  nel menu.
 8. Scegliere il tempo di cottura. Il tempo predefinito è impostato a 30 minuti.
- I seguenti ingredienti dovrebbero cuocere entro il tempo predefinito:



Cibo (fresco)	Quantità
Fagiolini	200g
Cavolini di bruxelles	200g
Carote, a fette	200g
Patate (quarti)	400g
Broccoli	200g
Cavolo	Quarto
Granoturco a pannocchia	2

9. E' possibile utilizzare solo i pulsanti h e min mentre il tempo sul display lampeggia.
10. Utilizzare il pulsante min per spostare il display sulle varie opzioni (5, 10, 15, 20, 25, 30, 35, 40, 45, 50 e 55).
11. Utilizzare il pulsante h per spostare il display sulle varie opzioni (1 e 2).
12. Per togliere l'impostazione di 2 ora, premere di nuovo il pulsante h, mentre il tempo sul display sta lampeggiando.
 - Se non si preme alcun pulsante per 2 minuti, l'apparecchio ritorna alla modalità di standby.
13. E' possibile utilizzare l'opzione del timer con questo programma (vedi TIMER).
14. Premere il pulsante .
15. Il display inizierà il conto alla rovescia.
16. Alla fine del tempo di cottura, l'apparecchio entrerà in modalità "mantenere caldo".
17. La spia  si illuminerà.
18. È meglio rimuovere il cibo non appena cotto, per impedire che si inzuppi troppo.
19. Premere il pulsante . Aprire il coperchio. Togliere il cibo.

IMBIONDIRE/ROSOLARE/AMMORBIDIRE/BOLLIRE"

- È possibile utilizzare il programma COTTURA A VAPORE  nelle sue impostazioni di default, con il coperchio aperto, come una pentola ad alta temperatura per 5, 10, 15, 20, 25, 30 minuti, prima di cuocere con un altro programma.
- Utilizzare con un po' di olio per imbiondire carne e verdure, per saltare, per ammorbidire cipolle, sedano, porri, etc.
- Utilizzare con acqua o brodo per preriscaldare i liquidi di cottura.
- Quando si passa al programma principale, l'apparecchio è caldo e alcuni o tutti i vostri ingredienti saranno già nella ciotola.
- Non dovrete più lavare la pentola che avreste dovuto utilizzare durante la preparazione.

PORRIDGE/RISOTTO



Utilizzare il misurino per mettere i cereali (riso, avena, orzo, etc.) nella ciotola.



Porridge

- Utilizzare la scala a destra, dentro la ciotola, che è contrassegnata da ½ a 1½.
- Non riempire oltre l'indicatore di livello **max**.

Congee

Utilizzare la scala al centro, dentro la ciotola, che è contrassegnata da 1 a 3.

- Non riempire oltre l'indicatore di livello **max**.
 - Riempire la ciotola con acqua fino all'indicazione corrispondente al numero di misurini di cereali.
1. Chiudere il coperchio.
 2. Utilizzare il pulsante  per selezionare  nel menu.
 3. Scegliere il tempo di cottura. Il tempo predefinito è di 1 ora.
 4. E' possibile utilizzare solo i pulsanti h e min mentre il tempo sul display lampeggia.
 5. Utilizzare il pulsante min per spostare il display sulle varie opzioni (5, 10, 15, 20, 25, 30, 35, 40, 45, 50 e 55).





6. Utilizzare il pulsante h per spostare il display sulle varie opzioni (1, 2, 3 e 4).
7. Per togliere l'impostazione di 4 ore, premere di nuovo il pulsante h, mentre il tempo sul display sta lampeggiando.
 - Se non si preme alcun pulsante per 2 minuti, l'apparecchio ritorna alla modalità di standby.
8. E' possibile utilizzare l'opzione del timer con questo programma (vedi TIMER).
9. Premere il pulsante .
10. Il display inizierà il conto alla rovescia.
11. Alla fine del tempo di cottura, l'apparecchio entrerà in modalità "mantenere caldo".
12. La spia  si illuminerà.
13. Premere il pulsante . Aprire il coperchio. Togliere il cibo.

Risotto



Seguire la ricetta riportata più avanti in questo manuale.











TORTA

1. Scongelare completamente l'impasto congelato prima dell'uso.
2. Non riempire la ciotola per più della metà.
3. Passare dell'olio da cucina nella ciotola.
4. Mettere l'impasto nella ciotola.
5. Chiudere il coperchio.
6. Utilizzare il pulsante  per selezionare  nel menu.
7. Scegliere il tempo di cottura. Il tempo predefinito è impostato a 40 minuti.
8. Il tempo predefinito è impostato a 40 minuti.
9. E' possibile utilizzare solo i pulsanti h e min mentre il tempo sul display lampeggia.
10. Utilizzare il pulsante min per spostare il display sulle varie opzioni (5, 10, 15, 20, 25, 30, 35, 40, 45, 50 e 55).
11. Utilizzare il pulsante h per spostare il display sulle varie opzioni (1 e 2).
12. Per togliere l'impostazione di 2 ore, premere di nuovo il pulsante h, mentre il tempo sul display sta lampeggiando.
 - Se non si preme alcun pulsante per 2 minuti, l'apparecchio ritorna alla modalità di standby.
13. Una volta impostato il tempo, premere .
14. Il display inizierà il conto alla rovescia.
15. Alla fine del tempo di cottura, l'apparecchio entrerà in modalità "mantenere caldo".
16. La spia  si illuminerà.
17. È meglio rimuovere il cibo non appena cotto, per impedire che si inzuppi troppo.
18. Premere il pulsante . Aprire il coperchio. Togliere il cibo.

MANTENERE CALDO

- Se si vuole utilizzare la funzione mantenere caldo dopo un programma che non la supporta, quando la sola cosa che appare sul display è la spia lampeggiante , premere .
- Premere  per uscire da questa funzione.

TIMER

- E' possibile utilizzare il timer con ritardo con i programmi per minestra , yogurt , pane , vapore  e porridge .
- Fare questo immediatamente dopo avere impostato il tempo di cottura e prima di premere il pulsante di avvio (start) :
 1. Premere il pulsante . La spia  si illuminerà.
 2. Decidere quando si vuole che il cibo sia pronto.
 3. Ad esempio, se ora sono le 2.00 e si vuole che il cibo sia pronto per le 9.00, bisognerà impostare il tempo a 7 ore.
 4. Utilizzare i pulsanti h e min per impostare ora e minuti esatti.
 5. Premere il pulsante .

CURA E MANUTENZIONE









1. Scollegare l'apparecchio e lasciarlo raffreddare.
2. Togliere la spina dalla presa di corrente, quindi rimuovere il connettore dalla presa d'alimentazione dell'apparecchio.
3. Con il coperchio chiuso, afferrare la parte superiore del filtro e staccarlo dal coperchio. (FIG A).
4. Girarlo, per visualizzare le indicazioni sulla parte frontale
5. Tenere fermo il coperchio del filtro e ruotare il resto del filtro verso il lucchetto aperto . (FIG B).
6. Premere sui segni in basso nel coperchio interno e toglierlo dall'apparecchio (FIG C).
7. Lavare a mano le parti rimovibili.
8. Passare su tutte le superfici un panno pulito inumidito.
9. Non mettere alcuna parte dell'apparecchio in lavastoviglie.
10. Rimontare il filtro e riposizionarlo nel coperchio.
11. Ricollocare il coperchio interno nel coperchio.









RICICLOH







Per evitare problemi di salute ed ambientali dovuti a sostanze pericolose, gli apparecchi e le batterie ricaricabili e non ricaricabili contrassegnati con uno di questi simboli non devono essere smaltiti con i rifiuti urbani indifferenziati. Smaltire i prodotti elettrici ed elettronici e, quando possibile, le batterie ricaricabili e non ricaricabili, in un punto di raccolta autorizzato per il riciclo/la raccolta.

RICETTA

-  cucchiaio (15ml)
-  cucchiaio (5ml)
-  grammi
-  millilitri
-  misurino
-  gambo/costa (sedano)
-  manciata
-  uovo, medio (53-63 g)

-  pizzico
-  mazzetto
-  rametto
-  spicchio
-  lattina/barattolo
-  vasetto
-  sacchetto (7g)
-  uovo, grande (63-73 g)











CHILLI CON VERDURA E COUSCOUS

- 1 cipolla rossa, tritata
- 1 cipolla grande, tritata
- 2  aglio, sbucciato e tritato
- 1 peperone rosso, privato dei semi e tritato
- 1 peperone giallo, privato dei semi e tritato
- 1 peperone arancione, privato dei semi e tritato
- 1  coriandolo in polvere
- 1  di passata di pomodoro
- 850 ml brodo di vegetale
- 2  salsa piccante di pomodoro
- 120-140 ml couscous





Per servire:

formaggio grattugiato
un mazzetto di coriandolo, tritato







COTTURA LENTA







- 1  d'olio di oliva
- 1  fagioli di Lima
- 1  fagioli cannellini
- 1  jalapenos verdi
- 1  fagioli bianchi
- 1  pomodori a pezzetti
- 2  cumino in polvere
- 1  zucchero
- 2  peperoncino in polvere
- 2  origano secco

panna acida





Aprire il coperchio. Aggiungere l'olio. Selezionare  nel menu e premere . Aggiungere la cipolla e l'aglio. Cuocere fino a quando le cipolle si ammorbidiscono. Fare sgocciolare i fagioli e aggiungerli. Mettere da parte il couscous. Aggiungere gli altri ingredienti rimasti. Premere  due volte per arrestare il programma. Chiudere il coperchio. Selezionare . Aggiungere il couscous 30 minuti prima di fine cottura. Se la cottura è già terminata, selezionare  sul menu e cuocere ancora per circa 20 minuti. Servire in una ciotola con una manciata di formaggio, un po' di panna acida e una spruzzata di coriandolo fresco. Per un chilli vegetariano classico, eliminare il couscous.

CHILLI DI MANZO INFUOCATO DI NY

- 450 g manzo brasato
- 3  aglio, sbucciato e tritato
- 2  cumino in polvere
- 1  pepe di cayenna
- 1  paprica affumicata/chipotle in polvere
- 1 peperone verde
- 1  sale
- 1  foglie di basilico, tritate grossolanamente

- 1  d'olio di oliva
- 2 cipolle, tritate
- 2  peperoncino in polvere
- 2  salsa di pomodoro
- 2  pomodori
- 1  foglia di alloro
- 1  pepe nero
- 1  fagioli bianchi

STUFATO

Aprire il coperchio. Aggiungere l'olio. Selezionare  nel menu e premere . Tagliare la carne di manzo, i pomodori e il peperone a pezzetti. Imbiondire la carne, poi toglierla dal fuoco. Aggiungere le cipolle, l'aglio e tutte le erbe. Cuocere fino a quando le cipolle si ammorbidiscono. Aggiungere la carne. Preparare i fagioli. Aggiungere gli altri ingredienti rimasti. Premere  due volte per arrestare il programma. Chiudere il coperchio. Selezionare . Aggiungere i fagioli 30 minuti prima che finisca la cottura. Se la carne è ancora un po' dura alla fine del programma, aggiungere una tazza di acqua e fare funzionare il programma per la carne per altri 30 minuti.

YOGURT FATTO IN CASA





1200 ml latte

100 ml yogurt

opzione sapore



50 g bacche estive miste surgelate







1  miele

Aprire il coperchio. Aggiungere il latte. Selezionare  nel menu e premere . Fare scaldare il latte finché cominceranno a formarsi delle bolle ai bordi. Premere  due volte per arrestare il programma. Lasciare raffreddare il latte tra i 37°C e i 45°C. Mescolare lo yogurt al latte. Le parti devono essere mescolate bene, altrimenti lo yogurt sarà grumoso. Chiudere il coperchio. Selezionare  nel menu e premere . Attendere la fine del programma. Mettere lo yogurt nel frigorifero per raffreddarlo completamente. Riscaldare delicatamente le bacche in un pentolino. Aggiungere il miele. Quando le bacche cominciano a disfarsi, togliere dalla fiamma, lasciare raffreddare, poi mescolare con lo yogurt. Se si desidera conservare lo yogurt bisogna sterilizzare i vasetti da utilizzare. Metterli in forno a 100°C per 10 minuti. Lo yogurt si manterrà fino a 2 settimane in frigorifero.



YOGURT

TAGINE MAROCCHINO DI PESCE

- 2  aglio, sbucciato e tritato
- 1 peperone rosso, privato dei semi e tritato
- 2 pomodori a pezzetti
- 1  zenzero in polvere
- 1 stecca di cannella
- 120 ml vino bianco
- 120 ml brodo di pesce
- 675 g pesce (merluzzo/eglefino/salmone)
- 1 un mazzetto di coriandolo, tritato



- 1 cipolla, tritata
- 2  sedano, tritato
- 1  cumino in polvere
- 1  curcuma
- 1  pasta di harissa
- 1  di passata di pomodoro
- 1 limone
- 1  olive verdi
- sale e pepe



PESCE





Preparare il coriandolo. Aprire il coperchio. Aggiungere gli altri ingredienti rimasti. Chiudere il coperchio. Selezionare  nel menu e premere . Cuocere fino a quando il pesce comincia a sfaldarsi (40-60 minuti). Premere  due volte per arrestare il programma. Aggiungere il coriandolo. Condire e servire. Ottimo con il couscous.

MINISTRA DI PISELLI SPACCATI E STINCO DI MAIALE

COTTURA LENTA



1150 ml brodo di pollo
225 g piselli spaccati
1  sedano, tritata
1  timo, finemente tritato
1 stinco di maiale



1 cipolla, finemente tritata
1 carota, tritata
2  aglio (schiacciato)
1  foglia di alloro
pepe nero



Aprire il coperchio. Aggiungere il brodo. Selezionare  nel menu e premere . Portare a ebollizione. Cuocere a fuoco lento per 10 minuti. Aggiungere gli altri ingredienti rimasti. Premere  due volte per arrestare il programma. Chiudere il coperchio. Selezionare . Attendere la fine del programma. Preparare lo stinco di maiale. Eliminare la pelle e le ossa. Tagliare la carne a cubetti. Eliminare la foglia di alloro. Schiacciare i piselli spaccati con la parte posteriore di un cucchiaio di legno. Aggiungere la carne. Condire e servire. Il Paradiso in una ciotola!

SALMONE CON UN TOCCO PICCANTE

PESCE

2 filetti di salmone (con la pelle)
1  paprika
½  cumino in polvere
1  zucchero di canna morbido



1  d'olio di oliva
1  peperoncino in polvere
1  sale e pepe
1 limone

Mescolare paprika, polvere di chilli, cumino, zucchero, sale e pepe. Spruzzare sui filetti di salmone. Aprire il coperchio. Aggiungere l'olio. Selezionare  nel menu e premere . Attendere un paio di minuti per fare scaldare l'olio. Aggiungere i filetti, con la pelle rivolta verso il basso. Chiudere il coperchio. Si tratta di un'ottima combinazione tra cottura a vapore e frittura di pesce a pezzetti e si otterrà una pelle croccante. Servire con una fetta di limone. Un ottimo pasto leggero.



TORTA BROWNIE AL CIOCCOLATO

TORTA

170 g burro non salato
340 g zucchero
170 g cocco in polvere
110 g gocce di cioccolato al latte

3 
1  essenza di vaniglia
1  sale
75 g farina bianca



per servire: gelato alla vaniglia (facoltativo)





Mescolare il burro in una pentola a fuoco lento. Ricoprire la ciotola con un foglio di carta di alluminio imburato. Mescolare il burro fuso, lo zucchero, la polvere di cacao, la farina, le uova, la vaniglia ed il sale in un piatto. Incorporare le gocce di cioccolato. Mettere la pastella sulla carta d'alluminio all'interno della ciotola. Chiudere il coperchio. Selezionare  sul menu. Impostare il tempo di cottura a 1 ora e 30 minuti. Premere il pulsante . La torta dovrebbe avere i bordi ben cotti e rimanere cremosa al centro. Servire la torta calda, con sopra del gelato.

STEW IRLANDESE CON DUMPLINGS AL FORMAGGIO DI CAPRA

STUFATO





per lo stew:





1.8 kg spalla di agnello (cotta)
250 g bacon venato
950 ml brodo di agnello
1 cipolla grande, tritata
2  sedano, tritata
2  di passata di pomodoro

1  d'olio di oliva
3  aglio (schiacciato)
sale e pepe
2 carote, tritate
2  rosmarino, tritato
1  farina di mais

per i dumplings:

100 g farina fermentante
50 g grasso di rognone
75 ml acqua
40 g formaggio di capra (molle)
1  foglie di maggiorana secche

1  lievito in polvere
1  sale
1  prezzemolo secco
1  timo secco
1  pepe nero

per lo stew: Disossare la carne. Tagliare la carne e la pancetta a pezzetti. Aprire il coperchio. Selezionare  nel menu e premere . Aggiungere il brodo. Portare a ebollizione. Cuocere a fuoco lento per 10 minuti. Trasferire il brodo in una caraffa. Aggiungere l'olio. Aggiungere cipolla e soffritto fino a quando si ammorbidiscono. Aggiungere la carne, l'aglio, le erbe e le altre verdure e cuocere per 5 minuti. Aggiungere il brodo. Aggiungere il purè di pomodoro. Premere  due volte per arrestare il programma. Chiudere il coperchio. Selezionare .

per i dumplings: Mescolare a mano tutti gli ingredienti. Dividere la miscela in 6 palline. Lasciare riposare per 20 minuti.



per finire: Preparare una pasta liscia con la farina di mais e un po' di acqua in una tazza. 30 minuti prima che la cottura finisca, aprire il coperchio. Mescolare l'impasto allo stew. Aggiungere i dumplings. Chiudere il coperchio. Attendere la fine del programma, poi servire. Una ciotola favolosa di cibo tradizionale!

- Se non avete dell'agnello cotto, potete usare dell'agnello crudo, con il programma a cottura lenta anziché il programma dello stufato, quindi continuare dalla fase di preparazione dei dumplings.

CARCIOFO COTTO A VAPORE

VAPORE 

1 	aglio, sbucciato e tritato	2	carciofi tondi
	rametti di erbe (dragoncello, menta, prezzemolo, timo)	1	limone





Tagliare a fette il limone. Tagliare il gambo con la parte inferiore di ogni carciofo. Tagliare il quarto superiore di ogni carciofo. Scartare tutte le foglie danneggiate. Strofinare le superfici tagliate con una fetta di limone. Mettere le fette di limone nel cestello. Aggiungere i rametti di erbe. Aggiungere l'aglio. Mettere il carciofo sopra. Riempire di acqua fino al livello 2 sulla scala a sinistra, all'interno della ciotola. Mettere il cestello sopra la ciotola. Chiudere il coperchio. Selezionare  nel menu e premere . I carciofi sono cotti quando le foglie esterne possono essere rimosse facilmente. Servire caldo o freddo con salsa vinaigrette. Fantastico!

ORZO PERLATO E FAGIOLI BORLOTTI IN UN'UNICA PENTOLA

STUFATO 

1 	d'olio di oliva	1 	fagioli borlotti
175 g	orzo perlato	1	cipolla, finemente tritata
1 	pomodori a pezzetti	1 	di passata di pomodoro
1000 ml	brodo di vegetale	2 	prezzemolo (tritato)
125 ml	vino rosso secco		sale e pepe



per servire: hot chilli oil (olio di peperoncino piccante) (facoltativo)

Aprire il coperchio. Selezionare  nel menu e premere . Aggiungere il brodo. Portare a ebollizione. Cuocere a fuoco lento per 10 minuti. Trasferire il brodo in una caraffa. Aggiungere l'olio. Aggiungere cipolla e soffritto fino a quando si ammorbidiscono. Aggiungere il vino e cuocere per alcuni minuti. Aggiungere l'orzo perlato e mescolare fino a quando inizia a prendere il colore del vino. Fare sgocciolare i fagioli e aggiungerli. Aggiungere i pomodori. Aggiungere il brodo. Premere  due volte per arrestare il programma. Chiudere il coperchio. Selezionare . 30 minuti prima che la cottura finisca, aprire il coperchio. Controllare la quantità di liquido nella ciotola. Aggiungere 150ml di acqua calda, se necessario. Chiudere il coperchio. Attendere la fine del programma. Servire con pane fresco con la crosta e una spruzzata di hot chilli oil.

BUDINO CON PAN DI SPAGNA (SPONGE PUDDING) E SCIROPPO



VAPORE 





115 g	burro	2	
100 g	zucchero raffinato	1/4 	essenza di vaniglia
175 g	farina fermentante	2 	latte
4 	sciropo dorato		

Sbattere le uova in una ciotola. Preparare una crema di burro e zucchero in una ciotola. Aggiungere gradualmente le uova, poi la vaniglia, e infine la farina. Aggiungere mescolando il latte. Ungere una pirofila da forno da 1200ml. Versare lo sciroppo nella parte inferiore della pirofila da forno e mettere la miscela nella parte superiore. Ricoprire con carta da forno, poi con carta d'alluminio, e legare la parte superiore con del filo. Aprire il coperchio. Mettere la pirofila da forno all'interno della ciotola nell'apparecchio. Aggiungere abbastanza acqua bollente nella ciotola nell'apparecchio fino a raggiungere 3cm al di sotto della pirofila da forno. Chiudere il coperchio. Selezionare  sul menu. Impostare il tempo di cottura a 1 ora e 30 minuti. Premere il pulsante . Attendere la fine del programma. Capovolgere su un piatto e servire caldo. E' un ottimo budino per qualsiasi periodo dell'anno!!!

PAGNOTTA BIANCA

PANE 



1 	sciroppo dorato	1 	burro
320 ml	latte	1 	lievito secco
500 g	farina di pane bianco di qualità	1 	sale

Aprire il coperchio. Aggiungere il latte. Selezionare  nel menu e premere . Fare scaldare il latte finché cominceranno a formarsi delle bolle ai bordi. Versare il latte in una caraffa. Premere  due volte per arrestare il programma. Lasciare raffreddare il latte tra i 37°C e i 45°C. Mescolare il burro in una pentola a fuoco lento. Mescolare la farina e il sale in una ciotola. Aggiungere il lievito, il burro e lo sciroppo. Aggiungere il latte ed impastare formando una palla. Se la miscela è molto appiccicosa, aggiungere un po' di farina in più. Coprire e lasciare in un posto caldo per 10 minuti. Impastare ancora. Coprire e lasciare in un posto caldo per 10 minuti. Aprire il coperchio. Selezionare  nel menu e premere . Chiudere il coperchio. 30 minuti prima che la cottura finisca, aprire il coperchio. Capovolgere il pane. In questo modo si darà un po' di colore e di croccantezza alla parte superiore della pagnotta. Attendere la fine del programma. Servire con fiocchetti di burro.



SODA BREAD (PANE TRADIZIONALE IRLANDESE SENZA LIEVITO)

PANE 

1 	miscela per soda bread	burro
350 ml	acqua	





Aprire il coperchio. Ungere la ciotola con il burro. Selezionare  sul menu. Chiudere il coperchio. Impostare il tempo di cottura a 2 ore e 15 minuti. Premere il pulsante . Lasciare riscaldare. Versare la miscela di soda bread in una ciotola. Aggiungere l'acqua. Lavorare a mano formando una palla. Aprire il coperchio. Versare l'impasto nella ciotola. Dividere la pasta in quarti con uno spatola di plastica. Chiudere il coperchio. 30 minuti prima che la cottura finisca, aprire il coperchio. Capovolgere il pane. In questo modo si darà un po' di colore e di croccantezza alla parte superiore della pagnotta. Attendere la fine del programma. Fare raffreddare su un ripiano. Servire da solo con burro salato o con un pasto.

RISOTTO PER MULTI-COOKER CON LA BARBABIETOLA PORRIDGE/RISOTTO

400 g	barbabetola	2 	d'olio di oliva
250 g	riso arborio/per risotto	1	cipolla, finemente tritata
250 ml	vino bianco	2 	aglio, sbucciato e tritato
900 ml	brodo di vegetale / brodo di pollo	1 	timo, finemente tritato

per finire:





100 ml	yogurt	1 	prezzemolo (tritato)
1 	burro		

Aprire il coperchio. Selezionare  nel menu e premere . Aggiungere il brodo. Portare a ebollizione. Cuocere a fuoco lento per 10 minuti. Trasferire il brodo in una caraffa. Premere  due volte per arrestare il programma. Selezionare  nel menu e premere . Lasciare riscaldare. Pelare la barbabietola e tagliarla a cubetti di 1cm. Mettere la barbabietola, l'aglio e la cipolla nella ciotola. Cuocere fino a quando le cipolle si ammorbidiscono. Aggiungere mescolando il riso. Chiudere il coperchio e cuocere per 3-4 minuti. Aprire il coperchio. Aggiungere mescolando il vino. Chiudere il coperchio e cuocere per 3-4 minuti. Aprire il coperchio. Aggiungere il timo. Aggiungere il brodo. Chiudere il coperchio. Attendere la fine del programma. Controllare il riso - dovrebbe essere leggermente al dente, ma non duro. Se non è pronto, aggiungere un po' d'acqua e cuocere ancora per qualche minuto.

Mescolare con del burro - in questo modo si darà al risotto la sua brillantezza. Servire con un po' di yogurt e spruzzare con del prezzemolo. E' veramente un buon piatto sia come primo che come pranzo leggero.

RISO SAVORITO

RISO 

2 	riso		acqua
1	dado (vegetale)	2	carote, tritate
1	peperone rosso, privato dei semi e tritato	2 	sedano, tritato
1 	curcuma	1 	piselli (facoltativo)

Aprire il coperchio. Mettere il riso nella ciotola. Riempire di acqua fino al livello 2 sulla scala a sinistra, all'interno della ciotola. Schiacciare il dado e mescolarlo all'acqua. Aggiungere gli altri ingredienti rimasti. Chiudere il coperchio. Selezionare . Attendere la fine del programma, poi servire. Se il riso non è ancora pronto, lasciarlo per alcuni minuti, con il coperchio chiuso, per far formare il vapore.

PORRIDGE



PORRIDGE/RISOTTO 

2 	farina d'avena		acqua
1/4 	sale	2 	zucchero

per servire:

zucchero di canna

latte / panna fresca

Aprire il coperchio. Aggiungere la farina d'avena, il sale e lo zucchero. Riempire di acqua fino al livello 1 1/2 sulla scala a destra, all'interno della ciotola. Chiudere il coperchio. Selezionare  nel menu e premere . Attendere la fine del programma. Servire con latte o panna. Spruzzare con zucchero di canna bruno. Se si desidera, si possono aggiungere delle albicocche secche tritate o prugne tagliate a metà (senza nocciolo) 15 minuti prima della fine del tempo di cottura. Il porridge rimasto può essere conservato in frigorifero fino a 2 giorni, poi deve essere riscaldato.

PORRIDGE ALLE NOCI



PORRIDGE/RISOTTO 

1/2 	fiochi d'avena		acqua
120 ml	latte	3 	noce di cocco essiccata
1 	cannella macinata		

per servire:





sciroppo dorato





mandorle a pezzetti

Aprire il coperchio. Aggiungere l'avena, la cannella, la noce di cocco e il latte. Riempire di acqua fino al livello 1/2 sulla scala a destra, all'interno della ciotola. Chiudere il coperchio. Selezionare  nel menu e premere . Attendere la fine del programma. Versare lo sciroppo dorato e spruzzare delle mandorle a pezzetti sopra.

GRANDE MINESTRA AL POMODORO



MINESTRA 





1	cipolla, tritata	1 	d'olio di oliva
1 	pomodori a pezzetti	2	pomodori a pezzetti
1	peperone rosso, privato dei semi e tritato	2	patate
550 ml	brodo di pollo	1 	di passata di pomodoro
1 	erbe miste essiccate	1 	pepe nero



Aprire il coperchio. Aggiungere il brodo. Selezionare  nel menu e premere . Portare a ebollizione. Cuocere a fuoco lento per 10 minuti. Trasferire il brodo in una caraffa. Premere  due volte per arrestare il programma. Sbucciare e tagliare a cubetti le patate. Selezionare  nel menu e premere . Aggiungere l'olio. Aggiungere la cipolla e il peperone dolce. Cuocere fino a quando le cipolle si ammorbidiscono. Aggiungere il brodo. Aggiungere gli altri ingredienti rimasti. Chiudere il coperchio. Attendere la fine del programma. Regolare il condimento. Servire con pane con la crosta.

POLLO CON POMODORI E FUNGHI

CARNE 



2	petti di pollo, senza pelle e disossati
450 g	funghi marroni, tagliuzzati
2 	aglio, sbucciato e tritato
1 	salsa Worcestershire
	sale e pepe



1 	d'olio di oliva
1 	pomodori a pezzetti
1 	salsa di pomodoro
1 	origano secco

Aprire il coperchio. Selezionare  nel menu e premere . Aggiungere l'olio. Condire i petti di pollo con sale e pepe e metterli nella ciotola. Girare la carne per rosolare entrambi i lati. Aggiungere l'aglio e i funghi. Cuocere per 3-4 minuti, girando il pollo una volta. Aggiungere i pomodori, la salsa Worcestershire, la salsa di pomodoro e l'origano. Continuare la cottura, girando il pollo ancora una volta. Controllare che il pollo sia completamente cotto. Servire con pasta, patate o riso. Un piatto rapido e saporito che si può conservare.

COSTINE BRASATE ALLA BIRRA SCURA (STOUT) CON ACERO E SOIA CARNE



1 kg	costine di pancetta di maiale
350 ml	birra Guinness/stout
140 ml	brodo di manzo / brodo di maiale
60 ml	sciroppo di acero / miele



1	cipolla, tritata
1 	d'olio di oliva
3 	aglio, sbucciato e tritato
2 	salsa scura di soia





Aprire il coperchio. Selezionare  sul menu. Aggiungere l'olio. Impostare il tempo di cottura a 1 ora e 45 minuti. Premere il pulsante . Aggiungere le costine e imbrionire per 5 minuti - girando di tanto in tanto. Preparare le costine. Aggiungere la cipolla e l'aglio. Cuocere fino a quando le cipolle si ammorbidiscono. Rimettere le costine nella ciotola. Mescolare la birra Guinness, il brodo, lo sciroppo di acero e la salsa di soia. Chiudere il coperchio. Attendere la fine del programma. Condire e servire. Ottimo come antipasto o come parte di un buon pranzo misto.

MINESTRA CON CHORIZO, CAVOLO E MELA





MINESTRA 

¼	salsiccia di chorizo, finemente tritata
1	mela
2 	sedano, tritata
¼	cavolo cappuccio, finemente tritato
2 	aglio, sbucciato e tritato
1 	sale
850 ml	brodo di vegetale







1	cipolla, finemente tritata
2	carote, tritate
2	pomodori a pezzetti
1 	di passata di pomodoro
1 	pepe di cayenna
1 	pepe nero





Aprire il coperchio. Selezionare  nel menu e premere . Saltare il chorizo per 2 minuti. Aggiungere la cipolla e l'aglio. Cuocere fino a quando le cipolle si ammorbidiscono. Sbucciare la mela, togliere il torsolo e tagliarla a pezzetti. Aggiungere gli altri ingredienti rimasti. Premere  due volte per arrestare il programma. Chiudere il coperchio. Selezionare  nel menu e premere . Attendere la fine del programma. Si tratta di un'ottima minestrina e se si lascia riposare una notte in frigorifero, il sapore sarà ancora migliore.

PUNTA DI PETTO IN UN'UNICA PENTOLA

1 kg	punta di petto
2 	aglio, sbucciato e tritato
50 g	chorizo, affettato
2 	cipolle rosse, tritate
600 ml	brodo di manzo
2 	erbe miste essiccate
6-8	patate (piccole)
2 	salsa Worcestershire

COTTURA LENTA

2 	di passata di pomodoro
2 	foglia di alloro
2 	carote
3 	sedano
2 	rosmarino, tritato
1 	pomodori a pezzetti
	sale e pepe

Lasciare le patate con la pelle. Tagliare le patate, le carote e il sedano a pezzi. Condire la punta di petto con sale e pepe. Aprire il coperchio. Selezionare  nel menu e premere . Aggiungere il brodo. Portare a ebollizione. Cuocere a fuoco lento per 10 minuti. Trasferire il brodo in una caraffa. Saltare il chorizo per 2 minuti. Aggiungere la carne. Imbiondire tutta la carne. Aggiungere le cipolle, l'aglio, le patate, il sedano e le carote. Se ci sono altri ortaggi da consumare, è possibile aggiungerli. Cuocere fino a quando le cipolle si ammorbidiscono. Aggiungere il brodo. Aggiungere gli altri ingredienti rimasti. Premere  due volte per arrestare il programma. Selezionare . Attendere la fine del programma, poi servire. Ci vorrebbero 8 ore di cottura, ma la carne potrebbe essere pronta dopo 5 ore.





Lea las instrucciones, guárdelas en un lugar seguro y, en caso de dar el aparato a otra persona, entréguelas también. Retire todo el embalaje antes de usar el aparato.

MEDIDAS DE SEGURIDAD IMPORTANTES

Siga las precauciones básicas de seguridad, incluyendo:

Este aparato puede ser utilizado por niños mayores de 8 años y por personas con discapacidad física, mental o sensorial o sin experiencia en su manejo, siempre que sean supervisadas o guiadas por otra persona y comprendan los posibles riesgos. Los niños no deben jugar con el aparato. Los niños solo deben realizar tareas de limpieza y mantenimiento si son mayores de 8 años y están supervisados por un adulto. Mantenga el aparato y el cable fuera del alcance de niños menores de 8 años.

Si el conector o el cable están dañados, deberán ser sustituidos por un conjunto especial de cable y conector, que podrá pedir al fabricante o a su representante autorizado.

-  No utilice el aparato cerca de bañeras, duchas, lavabos u otros recipientes que contengan agua.
-  El uso inadecuado del aparato puede ocasionar heridas.
-  Las superficies del aparato estarán calientes. El calor residual mantendrá las superficies calientes después de usar el aparato.
 - No ponga carne congelada ni carne de ave en el aparato de cocinar a vapor – descongélela antes de usar.
 - Cocine la carne, aves y derivados (carne picada, hamburguesas, etc.) hasta que salgan los jugos. Cocine el pescado hasta que su carne quede totalmente opaca.
 - No trate de cocer nada en el cuerpo del arrocero. Cuezalo sólo en el bol extraíble.
 - No llene el aparato por encima de la señal de max.
 - No cubra el aparato ni ponga nada sobre él.
 - Desenchúfelo de la toma de corriente y extraiga el conector de la toma de alimentación del aparato.
 - Cuando no lo use, desenchufe el aparato.
 - No ponga ningún otro acoplamiento o accesorio (recambio) que no haya sido adquirido del fabricante.
 - No use el aparato para ningún fin distinto a los descritos en estas instrucciones.
 - No use el aparato si está dañado o si no funciona bien.

SOLO PARA USO DOMÉSTICO



ILUSTRACIONES

- | | |
|----------------------|------------------|
| 1. Panel de control | 5. Taza medidora |
| 2. Tapa | 6. Cesta |
| 3. Cierre de la tapa | 7. Bol |
| 4. Tapa interior | 8. Conector |

PREPARACIÓN



1. Ponga el aparato en una superficie estable, nivelada y resistente al calor.
2. No use el aparato cerca o debajo de cortinas, mangas, armarios, o cualquier otra cosa que sea susceptible de ser dañado por el vapor.
3. Tenga guantes para el horno (o un trapo) a mano y un salvamanteles resistente al calor o plato para poner el bol después de la cocción.
4. Ponga el bol dentro del arrocero.
5. De un vuelta en cada sentido al bol para asegurar que el fondo del bol está en contacto con la resistencia.

ARROZ



1. Utilice la taza medidora para poner el arroz en el bol.
2. No emplee más de 10 tazas de arroz.
3. Utilice la escala de la parte izquierda del interior del bol, que tiene unas marcas que van del 2 al 10
4. Llene el bol con agua hasta el número correspondiente al número de tazas de arroz que vaya a usar.
5. Cierre la tapa
6. Pulse el botón . El botón se iluminará.
7. Los segmentos exteriores de la pantalla parpadearán cuando la comida se está calentando.
8. La pantalla mostrará entonces el tiempo de cocinado restante (13 minutos) y la cuenta atrás.
9. Cuando el aparato haya terminado de cocinar, se pondrá en modo "mantener caliente".
10. Se encenderá el piloto .
11. Abra la tapa.
12. Levante el bol y déjelo en un salvamanteles resistente al calor o un plato.
13. Pulse el botón .
14. Use la espátula para girar y mezclar el arroz, para dejar escapar el vapor.
15. A veces la capa de arroz que está en contacto con el bol forma una costra.
16. Si a usted no le gusta la costra, basta con que la retire con la espátula al servir el arroz.







COCCIÓN LENTA

1. Dorar carne y vegetales (ver el apartado "DORAR/SALTEAR/POCHAR/HERVIR").
2. Hervir el líquido con el que se va a cocinar (ver el apartado "DORAR/SALTEAR/POCHAR/HERVIR").
3. Colocar los ingredientes sólidos en el bol y añadir a continuación el líquido con el que se va a cocinar.
4. Cierre la tapa
5. Pulse el botón . El botón se iluminará.
6. La pantalla mostrará 8 horas e iniciará una cuenta atrás.
7. Cuando el aparato haya terminado de cocinar, se pondrá en modo "mantener caliente".
8. Se encenderá el piloto .
9. Pulse el botón . Abra la tapa. Retirar la comida.





ESTOFAR

1. Dorar carne y vegetales (ver el apartado "DORAR/SALTEAR/POCHAR/HERVIR").
2. Hervir el líquido con el que se va a cocinar (ver el apartado "DORAR/SALTEAR/POCHAR/HERVIR").
3. Colocar los ingredientes sólidos en el bol y añadir a continuación el líquido con el que se va a cocinar.
4. Cierre la tapa
5. Pulse el botón . El botón se iluminará.
6. La pantalla mostrará 1 hora e iniciará una cuenta atrás.
7. Cuando el aparato haya terminado de cocinar, se pondrá en modo "mantener caliente".
8. Se encenderá el piloto .
9. Pulse el botón . Abra la tapa. Retirar la comida.

CARNE

1. Unte bien los ingredientes con aceite de cocina.
2. Unte la superficie de los ingredientes con las especias que vaya a utilizar.
3. Ponga en el bol una cucharada de aceite de cocina.
4. Coloque los alimentos en el bol.
5. Cierre la tapa
6. El tiempo de cocinado depende del tamaño de los ingredientes.
7. No cocine más de unos 500 gramos de comida de una sola vez.
8. Para la carne de vacuno, recomendamos tiempos de cocción de 10 minutos + 10 minutos por cada 100 gramos de peso.
9. No cocine carne de cerdo o de ave durante menos de 5, 10, 15, 20, 25, 30 minutos.
10. Utilice el botón  para seleccionar  en el menú.
11. Seleccione el tiempo de cocción. El tiempo de cocción por defecto es de 20 minutos.
12. Solo podrá utilizar los botones h y min mientras el tiempo que aparece en la pantalla esté parpadeando.
13. Utilice el botón min para desplazar la pantalla a través de las distintas opciones de minutos (10, 15, 20, 25, 5, 10, 15, 20, 25, 30, 35, 40, 45, 50, and 55).
14. Para cocinar durante 1 hora, pulse el botón h.
15. Para cancelar el ajuste a 1 hora, vuelva a pulsar el botón h mientras el tiempo que aparece en la pantalla esté parpadeando.
 - Si no pulsa ningún botón en 2 minutos, el aparato volverá al modo standby.
16. Pulse  cuando haya terminado de ajustar el tiempo.
17. La pantalla iniciará una cuenta atrás.
18. Cuando el aparato haya terminado de cocinar, se pondrá en modo “mantener caliente”.
19. Se encenderá el piloto .
20. Pulse el botón . Abra la tapa. Retirar la comida.

SOPA

1. Dorar carne y vegetales (ver el apartado “DORAR/SALTEAR/POCHAR/HERVIR”).
2. Colocar los ingredientes sólidos en el bol y añadir a continuación el líquido con el que se va a cocinar.
3. Cierre la tapa
4. Utilice el botón  para seleccionar  en el menú.
5. Seleccione el tiempo de cocción. El tiempo por defecto es de 1 hora.
6. Solo podrá utilizar los botones h y min mientras el tiempo que aparece en la pantalla esté parpadeando.
7. Utilice el botón min para desplazar la pantalla a través de las distintas opciones de minutos (10, 15, 20, 25, 5, 10, 15, 20, 25, 30, 35, 40, 45, 50, and 55).
8. Utilice el botón h para desplazar la pantalla a través de las distintas opciones de minutos (1, 2, 3, 4, and 5).
9. Para cancelar el ajuste a 5 hora, vuelva a pulsar el botón h mientras el tiempo que aparece en la pantalla esté parpadeando.
 - Si no pulsa ningún botón en 2 minutos, el aparato volverá al modo standby.
10. Con este programa tiene la opción de utilizar el temporizador (ver el apartado TEMPORIZADOR).
11. Pulse el botón .
12. La pantalla iniciará una cuenta atrás.
13. Cuando el aparato haya terminado de cocinar, se pondrá en modo “mantener caliente”.
14. Se encenderá el piloto .
15. Pulse el botón . Abra la tapa. Retirar la comida.

YOGUR

Fermento de yogur

Use 5, 10, 15, 20, 25, 30 ml (dos cucharillas) de:

- Yogur natural activo, que debe estar fresco (use yogures con suficiente fecha de caducidad).

Los resultados variarán según la marca de yogur que utilice.

Yogur que haya hecho anteriormente.

- Las bacterias pierden vigor con el tiempo, por lo que solamente podrá usar yogures hechos anteriormente unas diez veces. Use un nuevo fermento tras diez usos.





Fermento de yogur liofilizado, que puede adquirir en farmacias o tiendas de productos biológicos.

- Si las instrucciones de uso del fermento son distintas a las de este manual, siga las instrucciones del fabricante del fermento.



Leche

- La medida adecuada es un litro de leche.
- Obtendrá un yogur más espeso si utiliza leche entera en vez de leche desnatada.
- Para que el yogur sea aún más espeso, añada hasta 8 cucharaditas de leche en polvo a la leche.
- Puede también utilizar leche en polvo reconstituida o leche evaporada en lata.



Cómo hacer yogur

1. Antes que nada, es necesario eliminar las bacterias que hay en la leche para que no interactúen con las bacterias del fermento de yogur.
2. Mientras calienta la leche, deje el fermento de yogur a temperatura ambiente.
3. Abra la tapa.
4. Utilice el programa de VAPOR (DORAR/SALTEAR/POCHAR/HERVIR) para calentar leche justo hasta que empiece a hervir.
5. Caliente la leche hasta que empiecen a formarse burbujas en los extremos.
6. Deje enfriar la leche hasta que esté entre 37 y 45°C.
7. Eche el fermento de yogur en la leche y remueva.
8. La leche y el fermento deben mezclarse bien; de lo contrario, el yogur quedará grumoso.
9. Cierre la tapa
10. Utilice el botón  para seleccionar  en el menú.
11. Seleccione el tiempo de cocción. El tiempo por defecto es de 8 horas.
12. Solo podrá utilizar los botones h y min mientras el tiempo que aparece en la pantalla esté parpadeando.
13. Utilice el botón min para desplazar la pantalla a través de las distintas opciones de minutos (10, 15, 20, 25, 5, 10, 15, 20, 25, 30, 35, 40, 45, 50, and 55).
14. Utilice el botón h para desplazar la pantalla a través de las distintas opciones de minutos (6, 7, 8, 9, and 10).
15. Para cancelar el ajuste a 10 hora, vuelva a pulsar el botón h mientras el tiempo que aparece en la pantalla esté parpadeando.
 - Si no pulsa ningún botón en 2 minutos, el aparato volverá al modo standby.
16. Con este programa tiene la opción de utilizar el temporizador (ver el apartado TEMPORIZADOR).
17. Pulse el botón .
18. La pantalla iniciará una cuenta atrás.
19. Cuando el aparato haya terminado la cocción, se pondrá en modo de espera.
20. No mantendrá el yogur caliente.
21. Pulse el botón . Abra la tapa. Retirar la comida.





PAN

1. Antes de usar masas congeladas, descongélelas completamente.
2. No cocine más de unos 500 gramos de comida de una sola vez.
3. Unte el bol con aceite de cocina.
4. Coloque la masa en el bol.
5. Cierre la tapa
6. Utilice el botón  para seleccionar  en el menú.
7. Seleccione el tiempo de cocción. El tiempo por defecto es de 3 horas.
8. Solo podrá utilizar los botones h y min mientras el tiempo que aparece en la pantalla esté parpadeando.





9. Utilice el botón min para desplazar la pantalla a través de las distintas opciones de minutos (10, 15, 20, 25, 5, 10, 15, 20, 25, 30, 35, 40, 45, 50, and 55).
10. Utilice el botón h para desplazar la pantalla a través de las distintas opciones de minutos (1, 2, 3, 4, 5, and 6).
11. Para cancelar el ajuste a 6 hora, vuelva a pulsar el botón h mientras el tiempo que aparece en la pantalla esté parpadeando.
 - Si no pulsa ningún botón en 2 minutos, el aparato volverá al modo standby.
12. Con este programa tiene la opción de utilizar el temporizador (ver el apartado TEMPORIZADOR).
13. Pulse el botón .
14. La pantalla iniciará una cuenta atrás.
15. Cuando el aparato haya terminado de cocinar, se pondrá en modo "mantener caliente".
16. Se encenderá el piloto .
17. Pulse el botón . Abra la tapa. Retirar la comida.

PESCADO

1. Unte bien los ingredientes con aceite de cocina.
2. Unte la superficie de los ingredientes con las especias que vaya a utilizar.
3. Ponga en el bol una cucharada de aceite de cocina.
4. Coloque los alimentos en el bol.
5. Cierre la tapa
6. El tiempo de cocinado depende del tamaño de los ingredientes.
7. No cocine más de unos 500 gramos de comida de una sola vez.
8. Recomendamos tiempos de cocción de 10 minutos por cada 100 gramos de peso.
9. Utilice el botón  para seleccionar  en el menú.
10. Seleccione el tiempo de cocción. El tiempo de cocción por defecto es de 20 minutos.
11. Solo podrá utilizar los botones h y min mientras el tiempo que aparece en la pantalla esté parpadeando.
12. Utilice el botón min para desplazar la pantalla a través de las distintas opciones de minutos (10, 15, 20, 25, 5, 10, 15, 20, 25, 30, 35, 40, 45, 50, and 55).
13. Para cocinar durante 1 hora, pulse el botón h.
14. Para cancelar el ajuste a 1 hora, vuelva a pulsar el botón h mientras el tiempo que aparece en la pantalla esté parpadeando.
 - Si no pulsa ningún botón en 2 minutos, el aparato volverá al modo standby.
15. Pulse  cuando haya terminado de ajustar el tiempo.
16. La pantalla iniciará una cuenta atrás.
17. Cuando el aparato haya terminado de cocinar, se pondrá en modo "mantener caliente".
18. Se encenderá el piloto .
19. Es conveniente retirar la comida en cuanto esté cocinada para que no se seque.
20. Pulse el botón . Abra la tapa. Retirar la comida.

VAPOR

1. Llene el bol con agua fría hasta la marca 6.
2. Coloque la cesta sobre la parte superior del bol y ponga la comida en la cesta.
3. Para una cocción uniforme, corte todas las piezas de los alimentos en el mismo tamaño.
4. Para cocinar guisantes u otros alimentos que puedan romperse o caer al agua, prepare un paquete de papel de aluminio e introdúzcalos en él.
5. Tenga cuidado cuando retire el papel de aluminio – use guantes para el horno y cucharas largas de plástico.
6. Cierre la tapa
7. Utilice el botón  para seleccionar  en el menú.
8. Seleccione el tiempo de cocción. El tiempo de cocción por defecto es de 30 minutos.
 - Los alimentos se cocinarán en el tiempo por defecto:

Alimento (fresco)	Cantidad
Judías verdes	200g
Coles de bruselas	200g
Zanahorias (en rodajas)	200g
Patatas (cuartos)	400g
Brócoli	200g
Col	Un cuarto
Mazorcas de maíz	2

- Solo podrá utilizar los botones h y min mientras el tiempo que aparece en la pantalla esté parpadeando.
- Utilice el botón min para desplazar la pantalla a través de las distintas opciones de minutos (5, 10, 15, 20, 25, 30, 35, 40, 45, 50, and 55).
- Utilice el botón h para desplazar la pantalla a través de las distintas opciones de minutos (1, and 2).
- Para cancelar el ajuste a 2 hora, vuelva a pulsar el botón h mientras el tiempo que aparece en la pantalla esté parpadeando.
 - Si no pulsa ningún botón en 2 minutos, el aparato volverá al modo standby.
- Con este programa tiene la opción de utilizar el temporizador (ver el apartado TEMPORIZADOR).
- Pulse el botón
- La pantalla iniciará una cuenta atrás.
- Cuando el aparato haya terminado de cocinar, se pondrá en modo “mantener caliente”.
- Se encenderá el piloto
- Es conveniente retirar la comida en cuanto esté cocinada para que no se reblandezca.
- Pulse el botón . Abra la tapa. Retirar la comida.

DORAR/SALTEAR/POCHAR/HERVIR

- Puede utilizar durante 5, 10, 15, 20, 25, 30 minutos el programa de VAPOR en su ajuste de tiempo por defecto, con la tapa abierta, como si fuera un recipiente resistente a las altas temperaturas, antes de pasar a cocinar con otro programa.
- Utilícelo con un poco de aceite para dorar la carne y los vegetales, saltear, pochar cebolla, apio, puerros, etc.
- Utilícelo con agua o caldo para precalentar líquidos que vaya a emplear al cocinar.
- Al conectarse al programa principal el aparato se calienta y parte o todos los ingredientes estarán ya dentro del bol.
- No hace falta que lave el recipiente que ha utilizado para la preparación.

PORRIDGE / RISOTTO



Utilice la taza medidora para poner en el bol cereales (arroz, avena, cebada, etc.).

Porridge

- Utilice la escala de la parte derecha del interior del bol, que tiene unas marcas que van de ½ a 1½.
- No llene el aparato por encima de la señal de **max**.

Congee





- Utilice la escala del centro en el interior del bol, que tiene unas marcas que van de 1 a 3.
 - No llene el aparato por encima de la señal de **max**.
- Llene el bol con agua hasta el número correspondiente al número de tazas de cereal que vaya a usar.
 - Cierre la tapa
 - Utilice el botón para seleccionar en el menú.
 - Seleccione el tiempo de cocción. El tiempo por defecto es de 1 hora.

5. Solo podrá utilizar los botones h y min mientras el tiempo que aparece en la pantalla esté parpadeando.
6. Utilice el botón min para desplazar la pantalla a través de las distintas opciones de minutos (5, 10, 15, 20, 25, 30, 35, 40, 45, 50, and 55).
7. Utilice el botón h para desplazar la pantalla a través de las distintas opciones de minutos (1, 2, 3, and 4).
8. Para cancelar el ajuste a 4 hora, vuelva a pulsar el botón h mientras el tiempo que aparece en la pantalla esté parpadeando.
 - Si no pulsa ningún botón en 2 minutos, el aparato volverá al modo standby.
9. Con este programa tiene la opción de utilizar el temporizador (ver el apartado TEMPORIZADOR).
- 10.ulse el botón .
11. La pantalla iniciará una cuenta atrás.
12. Cuando el aparato haya terminado de cocinar, se pondrá en modo “mantener caliente”.
13. Se encenderá el piloto .
14. Pulse el botón . Abra la tapa. Retirar la comida.



Risotto

Siga la receta que mostramos más adelante en este manual.







REPOSTERÍA

1. Antes de usar masas congeladas, descongélelas completamente.
2. No llene el bol más de la mitad.
3. Unte el bol con aceite de cocina.
4. Coloque la masa en el bol.
5. Cierre la tapa
6. Utilice el botón  para seleccionar  en el menú.
7. Seleccione el tiempo de cocción. El tiempo de cocción por defecto es de 40 minutos.
8. El tiempo de cocción por defecto es de 40 minutos.
9. Solo podrá utilizar los botones h y min mientras el tiempo que aparece en la pantalla esté parpadeando.
10. Utilice el botón min para desplazar la pantalla a través de las distintas opciones de minutos (5, 10, 15, 20, 25, 30, 35, 40, 45, 50, and 55).
11. Utilice el botón h para desplazar la pantalla a través de las distintas opciones de minutos (1, and 2).
12. Para cancelar el ajuste a 2 hora, vuelva a pulsar el botón h mientras el tiempo que aparece en la pantalla esté parpadeando.
 - Si no pulsa ningún botón en 2 minutos, el aparato volverá al modo standby.
13. Pulse  cuando haya terminado de ajustar el tiempo.
14. La pantalla iniciará una cuenta atrás.
15. Cuando el aparato haya terminado de cocinar, se pondrá en modo “mantener caliente”.
16. Se encenderá el piloto .
17. Es conveniente retirar la comida en cuanto esté cocinada para que no se reblandezca.
18. Pulse el botón . Abra la tapa. Retirar la comida.

MANTENER CALIENTE

- Si quiere usar la función de mantener caliente después de haber utilizado un programa que no es compatible con ella, pulse  cuando lo único que aparezca en la pantalla sea la luz  parpadeando.
- Pulse  para salir de esta función.

TEMPORIZADOR

- Puede usar el temporizador que marca el tiempo de cocinado restante con los programas para sopa , yogur , pan , vapor , y porridge .
- Haga esto inmediatamente después de haber ajustado el tiempo de cocinado y antes de pulsar el botón de inicio (start)  :

1. Pulse el botón . Se encenderá el piloto .
2. Decida cuándo quiere que la comida esté lista.
3. Por ejemplo, si ahora son las 14:00 horas y quiere que la comida esté lista a las 21:00, deberá fijar el tiempo en 7 horas.
4. Utilice los botones **h** y **min.** para ajustar correctamente las horas y minutos.
5. Pulse el botón .

CUIDADO Y MANTENIMIENTO

1. Desenchufe el aparato y deje que se enfríe.
2. Desenchúfelo de la toma de corriente y extraiga el conector de la toma de alimentación del aparato.
3. Con la tapa cerrada, agarre la parte superior del filtro y tire de él hasta retirarlo de la tapa. (FIG A).
4. Dele la vuelta para ver las marcas del extemo frontal.
5. Sujete firmemente la tapa del filtro y gire el resto del filtro hacia el icono del candado abierto . (FIG B).
6. Presione sobre las pestañas situadas en la parte de abajo de la tapa interior, y sepárelo del aparato. (FIG C).
7. Lave a mano las piezas que puedan separarse.
8. Limpie todas las superficies con un paño húmedo limpio.
9. No ponga ninguna parte del aparato en el lavavajillas
10. Vuelva a armar el filtro y a ponerlo en la tapa.
11. Vuelva a poner la tapa interior en la tapa.



RECICLAJE



Para evitar problemas medioambientales y de salud derivados de sustancias peligrosas, los electrodomésticos y las pilas recargables y no recargables en las que aparezca uno de estos símbolos no deben eliminarse junto con los residuos urbanos no seleccionados. Deseche siempre los aparatos eléctricos y electrónicos y, cuando corresponda, las pilas recargables y no recargables, en puntos oficiales de recogida/reciclado adecuados.

RECETAS

- cucharada (15ml)
- cucharadita (5ml)
- g** gramos
- ml** mililitros
- taza medidora
- penca (apio)
- puñado
- 60** huevo, mediano (53-63 g.)

- pizca
- manojo
- ramito
- diente(s)
- lata
- frasco
- sobre (7g)
- 70** huevo, grande (63-73 g.)

CHILE CON VERDURAS Y CUSCÚS

- 1 cebolla roja, picada
- 1 cebolla grande, picada
- 2 de ajo, pelados y picados
- 1 pimiento rojo, sin pepitas y picado
- 1 pimiento amarillo, sin pepitas y picado
- 1 pimiento naranja, sin pepitas y picado
- 1 cilantro molido
- 1 de puré de tomate
- 850 ml cubito de caldo de verduras
- 2 salsa de tomate picante

COCCIÓN LENTA

- 1 aceite de oliva
- 1 judías blancas
- 1 judías cannellini
- 1 jalapeños verdes
- 1 frijoles rojos
- 1 tomates triturado
- 2 comino molido
- 1 azúcar
- 2 chile en polvo
- 2 orégano seco





120-140 ml cuscús

servir con:

queso rallado



crema agria





manejo pequeño de cilantro, picado

Abra la tapa. Añada el aceite. Seleccionar  en el menú y pulsar . Añada la cebolla y el ajo. Rehogar la cebolla hasta que esté tierna. Escurrir las judías y añadir las. Reservar el cuscús. Añadir el resto de ingredientes. Pulsar dos veces  para detener el programa. Cierre la tapa Seleccionar . Añadir el cuscús 30 minutos antes de que termine la cocción. Si la cocción está ya terminada, seleccionar  en el menú y cocinar durante unos 20 minutos más. Servir en un bol con un puñado de queso, un chorrito de crema agria y una pizca de cilantro fresco. Para obtener un chile vegetariano clásico, no añada el cuscús.

ESTOFADO IRLANDÉS (STEW) CON ALBÓNDIGAS AL QUESO DE CABRA ESTOFAR





para el estofado:

1.8 kg paletilla de cordero (cocida)
250 g beicon
950 ml caldo de cordero
1 cebolla grande, picada
2  apio, picado
2  de puré de tomate





1  aceite de oliva
3  ajo (machacado)
sal y pimienta
2 zanahorias, picadas
2  romero, picado
1  harina de maíz

para las albóndigas (dumplings):

100 g harina con levadura
50 g tocino de vaca
75 ml agua
40 g queso de cabra (blando)
1  mejorana seca

1  levadura
1  sal
1  perejil seco
1  tomillo en polvo
1  pimienta negra

para el estofado:

Separar la carne del hueso. Cortar la carne y el bacon en trozos pequeños. Abra la tapa. Seleccionar  en el menú y pulsar . Añada el caldo. Lleve a ebullición y remueva. Hierva a fuego lento durante 10 minutos. Pasar el caldo a una jarra. Añada el aceite. Añada la cebolla y dórela. Añadir la carne, las especias y el resto de verduras y cocer durante 5 minutos. Añada el caldo. Añadir el tomate triturado. Pulsar dos veces  para detener el programa. Cierre la tapa Seleccionar .

para las albóndigas (dumplings):





Mezclar a mano todos los ingredientes. Dividir la mezcla en seis albóndigas. Deje reposar durante 20 minutos.

para terminar:

Combinar en una taza la harina de maíz y un poco de agua hasta obtener una mezcla homogénea. Quitar la tapa 30 minutos antes de que termine la cocción. Incorporar la mezcla de harina de maíz al estofado, removiéndola. Añadir las albóndigas. Tapar. Esperar a que el programa termine, y servir. Un fantástico plato de comida casera

- Si no dispone de paletilla de cordero cocida, puede usar carne de cordero cruda, poner el programa de cocción lenta en vez del programa para estofados y seguir las instrucciones anteriores a partir del momento en que se añaden las albóndigas.

TERNERA CON CHILE PICANTE AL ESTILO NUEVA YORK ESTOFAR

450 g carne de ternera para guisar
3  de ajo, pelados y picados
2  comino molido
1  pimienta de cayena
1  pimentón ahumado / chipotle en polvo
1 pimienta verde
1  sal

1  aceite de oliva
2 cebollas, picadas
2  chile en polvo
2  salsa de tomate
2  tomates
1  hoja de laurel
1  pimienta negra

1 🍃 hojas de albahaca, poco picadas

1 🍲 frijoles rojos

Abra la tapa. Añada el aceite. Seleccionar 🏠 en el menú y pulsar ⬇️. Cortar la ternera, los tomates y el pimiento en trozos pequeños. Dorar la carne y retirarla del fuego. Añadir las cebollas, el ajo y todas las especias. Rehogar la cebolla hasta que esté tierna. Añada la carne. Reservar las judías. Añadir el resto de ingredientes. Pulsar dos veces ⏸️ para detener el programa. Cierre la tapa Seleccionar 🏠. Añadir las judías 30 minutos antes de que termine la cocción. Si al final del programa la carne sigue estando algo dura, añadir una taza de agua y meter al horno en programa para carnes durante otros 30 minutos

YOGUR CASERO

YOGUR 🍵

1200 ml leche

100 ml yogurt

con sabores

50 g mezcla congelada de bayas de verano

1 🍯 miel

Abra la tapa. Añadir la leche. Seleccionar 🏠 en el menú y pulsar ⬇️. Caliente la leche hasta que empiecen a formarse burbujas en los extremos. Pulsar dos veces ⏸️ para detener el programa. Deje enfriar la leche hasta que esté entre 37 y 45°C. Incorporar el yogur a la leche sin dejar de remover. La leche y el fermento deben mezclarse bien; de lo contrario, el yogur quedará grumoso. Cierre la tapa Seleccionar 🍵 en el menú y pulsar ⬇️. Esperar a que el programa termine. Meter el yogur en la nevera para que se enfríe del todo. Calentar las bayas de verano ligeramente en una cazuela. Añadir la miel. Cuando las bayas de verano comiencen a deshacerse, retírelas del fuego, déjelas enfriar y mézclelas con el yogur. Si desea guardar el yogur deberá esterilizar los frascos que vaya a utilizar. Caliente los frascos en el horno a 100°C durante 10 minutos. El yogur puede conservarse hasta 2 semanas en la nevera.

TAJÍN MARROQUÍ DE PESCADO

PESCADO 🐟

2 🍷 de ajo, pelados y picados

1 pimiento rojo, sin pepitas y picado

2 tomates triturado

1 🍷 jengibre molido

1 palito de canela

120 ml vino blanco

120 ml caldo de pescado

675 g pescado (bacalao / merluza/salmón)

1 manojo pequeño de cilantro, picado

1 cebolla, picada

2 🍷 apio, picado

1 🍷 comino molido

1 🍷 cúrcuma

1 🍷 pasta harissa

1 🍷 de puré de tomate

1 limón

1 🍷 aceitunas verdes

sal y pimienta

Reservar el cilantro. Abra la tapa. Añadir el resto de ingredientes. Cierre la tapa Seleccionar 🏠 en el menú y pulsar ⬇️. Cocinar hasta que el pescado comience a desmigarse (40-60 minutos). Pulsar dos veces ⏸️ para detener el programa. Añadir el cilantro. Ajustar de especias y servir. Es un plato ideal para acompañar con cuscús.

SOPA DE GUISANTES Y CODILLO DE CERDO

COCCIÓN LENTA 🍲

1150 ml caldo de pollo

225 g guisantes

1 🍷 apio, picado

1 🍷 tomillo, picado fino

1 codillo de cerdo

1 cebolla, picada fina

1 zanahoria, picada

2 🍷 ajo (machacado)

1 🍷 hoja de laurel

pimienta negra



Abra la tapa. Añada el caldo. Seleccionar 🏠 en el menú y pulsar ⬇️. Lleve a ebullición y remueva. Hierva a fuego lento durante 10 minutos. Añadir el resto de ingredientes. Pulsar dos veces ⏸️ para detener el programa. Cierre la tapa Seleccionar 🍲. Esperar a que el programa termine. Retirar el codillo. Desechar la piel y los huesos. Cortar la carne en dados. Desechar las hojas. Machacar los guisantes con el reverso de

una cuchara de madera. Añada la carne. Ajustar de especias y servir. ¡Una sopa divina!

SALMÓN AL TOQUE PICANTE

PESCADO

2	filetes de salmón (con piel)	1	aceite de oliva
1	✓ paprika	1	✓ chile en polvo
½	✓ comino molido	1	✓ sal y pimienta
1	✓ azúcar moreno blando	1	limón



Mezclar el pimentón, el chile en polvo, el azúcar, la sal y la pimienta. Espolvorear sobre los filetes de salmón. Abra la tapa. Añada el aceite. Seleccionar  en el menú y pulsar . Esperar un par de minutos hasta que el aceite esté caliente. Añadir los filetes con la piel hacia abajo. Cierre la tapa Tendremos una excelente combinación de trozos de pescado frito y cocido pero con la piel crujiente. Servir con una cuña de limón. Un excelente plato ligero.

TARTA DE BROWNIE DE CHOCOLATE

REPOSTERÍA

170 g	mantequilla sin sal	3	⑦⑩
340 g	azúcar	1	✓ esencia de vainilla
170 g	polvo de cacao	1	✓ sal
110 g	gotas de chocolate con leche	75 g	harina



servir con: helado de vainilla (opcional)

Funda la mantequilla en una cacerola a fuego lento. Cubrir el bol con papel de aluminio untado de mantequilla. Batir en un plato la mantequilla derretida, el azúcar, el cacao en polvo, la harina, los huevos, la vainilla y la sal. Envolver las gotas de chocolate en la masa. Poner la masa en el papel de aluminio que recubre el interior del bol. Cierre la tapa Seleccionar  en el menú. Fijar el tiempo de cocción en 1 hora 30 minutos. Pulse el botón . La tarta deberá quedar firme por los bordes y ligeramente cremosa en el centro. Servir la tarta caliente, con helado por encima.

alcachofas al vapor

 vapor

1	✓ de ajo, pelados y picados	2	alcachofas
	ramitos de especias (estragón, menta, perejil, tomillo)	1	limón





Cortar el limón en rodajas. Cortar cada alcachofa por el tallo, desechando la parte inferior del fruto. Cortar el cuarto superior de cada alcachofa. Desechar las hojas estropeadas. Frotar las superficies cortadas con una rodaja de limón. Poner las rodajas de limón en el cesto. Añadir los ramitos de especias. Añadir el ajo. Colocar encima la alcachofa. Llenar de agua hasta el nivel 2 de la escala de la izquierda del interior del bol. Colocar la cesta encima del bol. Cierre la tapa Seleccionar  en el menú y pulsar . Las alcachofas estarán cocidas cuando las hojas externas se puedan separar fácilmente. Servirlas calientes o frías, acompañadas de una vinagreta. ¡Un plato increíble!

ALUBIAS BORLOTTI CON CEBADA PERLADA (PLATO ÚNICO)

ESTOFAR

1	✓ aceite de oliva	1	alubias borlotti
175 g	cebada perlada	1	cebolla, picada fina
1	✓ tomates triturado	1	✓ de puré de tomate
1000 ml	cubito de caldo de verduras	2	✓ perejil (picado)
125 ml	vino tinto seco		sal y pimienta

servir con: aceite de chile picante (opcional)



Abra la tapa. Seleccionar  en el menú y pulsar . Añada el caldo. Lleve a ebullición y remueva. Hierva a fuego lento durante 10 minutos. Pasar el caldo a una jarra. Añada el aceite. Añada la cebolla y dórela. Añadir el vino y cocer durante unos pocos minutos. Añadir la cebada perlada y remover hasta que comience a coger el color del vino. Escurrir las alubias y añadir las. Añadir los tomates. Añada el caldo. Pulsar dos veces  para detener el programa. Cierre la tapa Seleccionar . Quitar la tapa 30 minutos antes de que termine la cocción. Comprobar la cantidad de líquido que hay en el bol. Añadir 150 ml de agua caliente si fuera necesario. Cierre la tapa Esperar a que el programa termine. Servir con pan crujiente recién hecho y un chorrito de aceite de chile picante.

PAN DE SODA

PAN 

1  preparado para pan de soda
350 ml agua



mantequilla





Abra la tapa. Untar el bol con mantequilla. Seleccionar  en el menú. Cierre la tapa Poner el tiempo de cocción en 2 horas 15 minutos. Pulse el botón . Dejar que se caliente. Poner el preparado para pan de soda en un bol. Añadir el agua. Mezclar a mano dando a la masa forma de bola. Abra la tapa. Poner la masa en el bol. Dividir la masa en cuartos con una espátula de plástico. Cierre la tapa Quitar la tapa 30 minutos antes de que termine la cocción. Dar la vuelta al pan. De este modo ayudaremos a que la parte de arriba del pan coja color y quede más crujiente. Esperar a que el programa termine. Deje enfriar en una bandeja de rejilla. Servir con mantequilla salada, solo o acompañando la comida.

PAN BLANCO DE MOLDE

PAN 

1  sirope de melaza
320 ml leche
500 g harina fuerte para pan blanco





1  mantequilla
1  levadura seca
1  sal



Abra la tapa. Añadir la leche. Seleccionar  en el menú y pulsar . Caliente la leche hasta que empiecen a formarse burbujas en los extremos. Pasar la leche a una jarra. Pulsar dos veces  para detener el programa. Deje enfriar la leche hasta que esté entre 37 y 45°C. Funda la mantequilla en una cacerola a fuego lento. Mezclar en un bol la harina y la sal. Añadir la levadura, la mantequilla y el sirope. Añadir la leche y amasar dando a la masa forma de bola. Si la mezcla es demasiado pegajosa, añadir un poco más de harina. Tapar y dejar reposar en un lugar cálido durante 10 minutos. Volver a amasar. Tapar y dejar reposar en un lugar cálido durante 10 minutos. Abra la tapa. Seleccionar  en el menú y pulsar . Cierre la tapa Quitar la tapa 30 minutos antes de que termine la cocción. Dar la vuelta al pan. De este modo ayudaremos a que la parte de arriba del pan coja color y quede más crujiente. Esperar a que el programa termine. Servir con unos hilos de mantequilla.

PUDIN ESPONJOSO CON SIROPE DE MELAZA

VAPOR 

115 g mantequilla
100 g azúcar glasé
175 g harina con levadura
4  sirope de melaza



2  
1/4  esencia de vainilla
2  leche

Batir los huevos en un bol. Preparar en un recipiente una crema de mantequilla y azúcar. Incorporar gradualmente los huevos, la vainilla y la harina en este orden. Incorporar la leche. Untar un recipiente de 1200ml resistente al horno. Poner el sirope en el fondo del recipiente resistente al horno, con la mezcla por encima. Cubrir con papel para horno y a continuación con papel de aluminio, y atar con cordel la parte superior. Abra la tapa. Colocar el recipiente resistente al horno dentro del bol del aparato. Añadir en el bol del aparato agua hirviendo suficiente para que llegue a 3cm por debajo del borde del recipiente resistente al horno. Cierre la tapa Seleccionar  en el menú. Fijar el tiempo de cocción en 1 hora 30 minutos. Pulse el botón . Esperar a que el programa termine. Darle la vuelta sobre un plato y servir caliente. ¡Un excelente pudin para cualquier época del año!

RISOTTO CON REMOLACHA EN ROBOT DE COCINA

PORRIDGE/ RISOTTO 





400 g remolacha
250 g arroz arborio o arroz para risotto.
250 ml vino blanco
900 ml cubito de caldo de verduras / caldo de pollo

2  aceite de oliva
1 cebolla, picada fina
2  de ajo, pelados y picados
1  tomillo, picado fino

para terminar:





100 ml yogurt
1  mantequilla

1  perejil (picado)

Abra la tapa. Seleccionar  en el menú y pulsar . Añada el caldo. Lleve a ebullición y remueva. Hierva a fuego lento durante 10 minutos. Pasar el caldo a una jarra. Pulsar dos veces  para detener el programa. Seleccionar  en el menú y pulsar . Dejar que se caliente. Pelar la remolacha y cortarla en dados de 1 cm. Poner en el bol la remolacha, el ajo y la cebolla. Rehogar la cebolla hasta que esté tierna. Incorporar el arroz. Tapar y cocinar durante 3-4 minutos. Abra la tapa. Incorporar el vino. Tapar y cocinar durante 3-4 minutos. Abra la tapa. Añadir el tomillo. Añada el caldo. Cierre la tapa Esperar a que el programa termine. Pruebe el arroz; deberá estar ligeramente al dente, pero sin llegar a estar duro. Si el arroz no está lo bastante hecho, añadir un poco de agua y dejar que cueza unos minutos más. Incorporar la mantequilla, que es lo que da al risotto su brillo característico. Servir con una pizca del yogur y espolvorear con perejil. Una opción igual de deliciosa como aperitivo que como comida ligera.

ARROZ SABROSO





ARROZ





2 	arroz		agua
1	cubito de caldo (verduras)	2	zanahorias, picadas
1	pimiento rojo, sin pepitas y picado	2 	apio, picado
1 	cúrcuma	1 	guisantes (opcional)

Abra la tapa. Poner el arroz en el bol. Llenar de agua hasta el nivel 2 de la escala de la izquierda del interior del bol. Añadir al agua el cubito de caldo machacado y remover. Añadir el resto de ingredientes. Cierre la tapa Seleccionar . Esperar a que el programa termine, y servir. Si el arroz no está lo bastante hecho, dejarlo cocer unos pocos minutos con la tapa puesta para que se haga al vapor.

SOPA DE TOMATE CONTUNDENTE







SOPA





1	cebolla, picada	1 	aceite de oliva
1 	tomates triturado	2	tomates triturado
1	pimiento rojo, sin pepitas y picado	2	patatas
550 ml	caldo de pollo	1 	de puré de tomate
1 	mezcla de hierbas secas	1 	pimienta negra

Abra la tapa. Añada el caldo. Seleccionar  en el menú y pulsar . Lleve a ebullición y remueva. Hierva a fuego lento durante 10 minutos. Pasar el caldo a una jarra. Pulsar dos veces  para detener el programa. Pelar las patatas y cortarlas en dados. Seleccionar  en el menú y pulsar . Añada el aceite. Añadir la cebolla y el pimiento. Rehogar la cebolla hasta que esté tierna. Añada el caldo. Añadir el resto de ingredientes. Cierre la tapa Esperar a que el programa termine. Ajustar de sal y especias. Servir con pan crujiente.

SOPA DE CHORIZO, REPOLLO Y MANZANA



SOPA





¼	chorizo, picado fino	1	cebolla, picada fina
1	manzana	2	zanahorias, picadas
2 	apio, picado	2	tomates triturado
¼	repollo, picado fino	1 	de puré de tomate
2 	de ajo, pelados y picados	1 	pimienta de cayena
1 	sal	1 	pimienta negra
850 ml	cubito de caldo de verduras		



Abra la tapa. Seleccionar  en el menú y pulsar . Sofreír el chorizo durante 2 minutos. Añada la cebolla y el ajo. Rehogar la cebolla hasta que esté tierna. Pelar la manzana y retirar el corazón y las pepitas. Añadir el resto de ingredientes. Pulsar dos veces  para detener el programa. Cierre la tapa Seleccionar  en el menú y pulsar . Esperar a que el programa termine. Una sopa deliciosa, que ganará en sabor si la prepara por la noche y la deja en la nevera para el día siguiente.

POLLO CON TOMATE Y CHAMPIÑONES



CARNE 

- 2 pechugas de pollo deshuesadas y sin piel
- 450 g champiñones marrones, picados
- 2  de ajo, pelados y picados
- 1  salsa Worcester
- sal y pimienta

- 1  aceite de oliva
- 1  tomates triturado
- 1  salsa de tomate
- 1  orégano seco



Abra la tapa. Seleccionar  en el menú y pulsar . Añada el aceite. Salpimentar las pechugas de pollo y ponerlas en el bol. Volver la carne para sellarla por los dos lados. Añadir el ajo y los champiñones. Cocinar durante 3-4 minutos, dándole la vuelta al pollo una vez. Añadir los tomates, la salsa Worcester, la salsa de tomate y el orégano. Continuar con la cocción, dándole la vuelta al pollo otra vez. Comprobar que el pollo está bien hecho. Servir con pasta, patatas o arroz. Una comida sencilla y sabrosa con ingredientes que siempre hay en casa.

PORRIDGE



- 2  harina de avena
- 1/4  sal

servir con:

azúcar moreno



Abra la tapa. Añadir la harina de avena, sal y azúcar. Llenar con agua hasta el nivel 1/2 de la escala de la parte interior derecha del bol. Cierre la tapa Seleccionar  en el menú y pulsar . Esperar a que el programa termine. Servir con leche o crema. Espolvorear con azúcar moreno oscuro. Si lo desea, puede añadir albaricoques secos en trozos o medias ciruelas (sin hueso) 15 minutos antes de que termine la cocción. El porridge sobrante puede conservarse hasta 2 días en la nevera y luego recalentarse.

PORRIDGE ALMENDRADO

- 1/2  copos de avena
- 120 ml leche
- 1  canela en polvo

servir con:



sirope de melaza



Abra la tapa. Añadir los copos de avena, canela, coco y leche. Llenar con agua hasta el nivel 1/2 de la escala de la parte interior derecha del bol. Cierre la tapa Seleccionar  en el menú y pulsar . Esperar a que el programa termine. Adornar con un chorrito de sirope de melaza y espolvorear por encima con trozos de almendra.

COSTILLAS ASADAS EN CERVEZA STOUT CON SIROPE DE ARCE Y SOJA

CARNE 

- 1 kg costillas de cerdo
- 350 ml cerveza Guinness / stout
- 140 ml caldo de ternera o de cerdo
- 60 ml sirope de arce / miel

- 1 cebolla, picada
- 1  aceite de oliva
- 3  de ajo, pelados y picados
- 2  salsa de soja oscura

Abra la tapa. Seleccionar  en el menú. Añada el aceite. Fijar el tiempo de cocción en 1 hora 45 minutos. Pulse el botón . Añadir las costillas y dorarlas durante 5 minutos, dándoles la vuelta de vez en cuando. Retirar las costillas. Añada la cebolla y el ajo. Rehogar la cebolla hasta que esté tierna. Volver a colocar las costillas en el bol. Incorporar la cerveza Guinness, el caldo, el sirope de arce y la salsa de soja Cierre la tapa Esperar a que el programa termine. Ajustar de especias y servir. Excelente como aperitivo o para una comida de piqueo.



PORRIDGE / RISOTTO

- agua
- 2  azúcar



leche / nata líquida

PORRIDGE / RISOTTO





- agua
- 3  coco deshidratado





almendras troceadas

PECHO DE TERNERA (PLATO ÚNICO)

1 kg	pecho de ternera
2 	de ajo, pelados y picados
50 g	chorizo, en rodajas
2	cebollas rojas, picadas
600 ml	caldo de ternera
2 	mezcla de hierbas secas
6-8	patatas (pequeñas)
2 	salsa Worcester

COCCIÓN LENTA

2 	de puré de tomate
2 	hoja de laurel
2	zanahorias
3 	apio
2 	romero, picado
1 	tomates triturado
	sal y pimienta

Dejar las patatas con piel. Cortar en trozos las patatas, las zanahorias y el apio. Salpimentar el pecho de ternera. Abra la tapa. Seleccionar  en el menú y pulsar . Añada el caldo. Lleve a ebullición y remueva. Hierva a fuego lento durante 10 minutos. Pasar el caldo a una jarra. Sofreír el chorizo durante 2 minutos. Añada la carne. Dorar todos los ingredientes. Añadir las cebollas, el ajo, las patatas, el apio y las zanahorias. Si tiene otros tubérculos que quiera aprovechar, puede añadirlos también. Rehogar la cebolla hasta que esté tierna. Añada el caldo. Añadir el resto de ingredientes. Pulsar dos veces  para detener el programa. Seleccionar . Esperar a que el programa termine, y servir. Aunque puede cocerse durante 8 horas sin problema, probablemente estará listo para comer en 5 horas.



Leia as instruções e guarde em lugar seguro. Forneça-as também caso venha a fornecer o aparelho a alguém. Retire todo o material de embalar antes da utilização.

MEDIDAS DE PRECAUÇÃO IMPORTANTES

Siga as seguintes instruções básicas de segurança:

Este aparelho pode ser usado por crianças com idade de 8 anos ou superior e pessoas com capacidades físicas, sensoriais ou mentais reduzidas ou com falta de experiência e conhecimentos, desde que supervisionadas/instruídas e que compreendam os riscos envolvidos. As crianças não devem brincar com o aparelho. A limpeza e manutenção por parte do utilizador não deverão ser feitas por crianças a não ser que tenham mais de 8 anos e sejam supervisionadas. Mantenha o aparelho e o cabo fora do alcance de crianças com menos de 8 anos.

Caso o conector ou o cabo se encontre danificado, deverá ser substituído por um conjunto específico disponível no fabricante ou num agente autorizado.

-  Não utilize o aparelho perto de casas de banho, duches, bacias ou outros recipientes que contêm água
-  Utilizar o aparelho incorretamente poderá resultar em ferimentos.
-  As superfícies do aparelho aquecerão. O calor residual manterá as superfícies quentes após a utilização.
 - Não coloque carne ou aves domésticas congeladas no aparelho – descongele completamente antes de utilizar.
 - Cozinhe carne, aves e derivados (picado, hambúrgueres, etc.) até o suco sair claro. Cozinhe o peixe até ficar totalmente opaco.
 - Não tente cozinhar nada no corpo do aparelho. Cozinhe apenas no recipiente extraível.
 - Não encha acima da marca **max**.
 - Não cubra o aparelho nem coloque seja o que for sobre ele.
 - Desligue a máquina da tomada de corrente e depois retire o conector da entrada de alimentação do aparelho.
 - Desligue o aparelho da tomada quando não o estiver a utilizar.
 - Não utilize acessórios ou peças que não sejam fornecidos pela nossa empresa.
 - Não utilize o aparelho para quaisquer outras finalidades senão as descritas nestas instruções.
 - Não utilize o aparelho se estiver danificado ou defeituoso.

APENAS PARA USO DOMÉSTICO

ESQUEMAS



- | | |
|-----------------------|-------------------|
| 1. Painel de controlo | 5. Copo de medida |
| 2. Tampa | 6. Cesto |
| 3. Fecho da tampa | 7. Recipiente |
| 4. Tampa interior | 8. Conector |





PREPARAÇÃO

1. Coloque o aparelho numa superfície estável, plana, resistente ao calor.
2. Não utilize o aparelho perto ou por baixo de cortinas, prateleiras, armários ou qualquer outro objecto que possa sofrer danos pelo vapor que se escapa.
3. Tenha uma pega (ou um pano de cozinha) à mão, e uma base ou prato termo-resistente para colocar o recipiente quando tiver acabado de cozinhar.
4. Coloque o recipiente dentro do aparelho.
5. Dê ao recipiente um quarto de volta para cada lado, para se certificar que a sua parte inferior faz bem contacto com a resistência.



ARROZ

1. Use o copo de medida para colocar o arroz dentro do recipiente.
2. Não utilizar mais de 10 copos de arroz.
3. Utilize a escala do lado esquerdo, dentro do recipiente, que exibe marcas de 2 a 10.
4. Encha o recipiente com água até ao número correspondente ao número de copos de arroz usados.
5. Feche a tampa.
6. Prima o botão . O botão brilhará.
7. As secções exteriores do visor piscarão enquanto a comida aquece.
8. O visor exibirá, então, o tempo de cozedura restante (13 minutos) e iniciará a contagem decrescente.
9. No final do tempo de cozedura, o aparelho entrará no modo de “aquecimento”.
10. A luz  acende-se.
11. Abra a tampa.
12. Retire o recipiente e coloque-o numa base ou num prato termo-resistente.
13. Prima o botão .
14. Utilize a espátula para virar e mexer o arroz, para que todo o vapor saia.
15. Por vezes, a camada de arroz em contacto com a cuba forma uma crosta.
16. Caso não pretenda, poderá removê-la com a espátula, após ter servido o arroz.





COZEDURA LENTA

1. Doure a carne e os legumes (consultar “DOURAR/SALTEAR/AMACIAR/FERVER”).
2. Ferva o líquido de confeção (consultar “DOURAR/SALTEAR/AMACIAR/FERVER”).
3. Coloque os ingredientes sólidos no interior do recipiente e, em seguida, adicione o líquido de confeção.
4. Feche a tampa.
5. Prima o botão . O botão brilhará.
6. O visor exibirá 8 horas e iniciará a contagem decrescente.
7. No final do tempo de cozedura, o aparelho entrará no modo de “aquecimento”.
8. A luz  acende-se.
9. Prima o botão . Abra a tampa. Retire os alimentos.

GUISADOS





1. Doure a carne e os legumes (consultar “DOURAR/SALTEAR/AMACIAR/FERVER”).
2. Ferva o líquido de confeção (consultar “DOURAR/SALTEAR/AMACIAR/FERVER”).
3. Coloque os ingredientes sólidos no interior do recipiente e, em seguida, adicione o líquido de confeção.
4. Feche a tampa.
5. Prima o botão . O botão brilhará.
6. O visor exibirá 1 hora e iniciará a contagem decrescente.
7. No final do tempo de cozedura, o aparelho entrará no modo de “aquecimento”.
8. A luz  acende-se.
9. Prima o botão . Abra a tampa. Retire os alimentos.

CARNE

1. Esfregue os alimentos com óleo alimentar na totalidade.
2. Esfregue os temperos na superfície dos alimentos.
3. Coloque uma colher de sopa de óleo alimentar no recipiente.
4. Coloque os alimentos no recipiente.
5. Feche a tampa.
6. O tempo depende do tamanho dos alimentos.
7. Não cozinhe mais de 500 g de alimentos (aprox.) de uma só vez.
8. Sugerimos tempos de cozedura de 10 minutos + 10 minutos por 100 g de peso para carne de vaca.
9. Não cozinhe porco ou aves por menos de 5, 10, 15, 20, 25, 30 minutos.
10. Use o botão  para selecionar  no menu.
11. Escolha o tempo de cozedura. O tempo predefinido é de 20 minutos.
12. Só poderá utilizar os botões h e min enquanto o tempo no visor estiver a piscar.
13. Use o botão min para mover o visor e visualizar as opções (10, 15, 20, 25, 5, 10, 15, 20, 25, 30, 35, 40, 45, 50 e 55).
14. Se quiser cozinhar durante 1 hora, prima o botão h.
15. Para anular a programação de 1 hora, prima o botão h novamente enquanto o tempo no visor estiver a piscar.
 - Se não realizar qualquer ação durante 2 minutos, o aparelho reverterá para o modo de espera.
16. Quando tiver programado o tempo, prima .
17. O visor iniciará a contagem decrescente.
18. No final do tempo de cozedura, o aparelho entrará no modo de “aquecimento”.
19. A luz  acende-se.
20. Prima o botão . Abra a tampa. Retire os alimentos.

PT

SOPA

1. Doure a carne e os legumes (consultar “DOURAR/SALTEAR/AMACIAR/FERVER”).
2. Coloque os ingredientes sólidos no interior do recipiente e, em seguida, adicione o líquido de confeção.
3. Feche a tampa.
4. Use o botão  para selecionar  no menu.
5. Escolha o tempo de cozedura. O tempo predefinido é de 1 hora.
6. Só poderá utilizar os botões h e min enquanto o tempo no visor estiver a piscar.
7. Use o botão min para mover o visor e visualizar as opções (10, 15, 20, 25, 5, 10, 15, 20, 25, 30, 35, 40, 45, 50 e 55).
8. Use o botão h para mover o visor e visualizar as opções (1, 2, 3, 4 e 5).
9. Para anular a programação de 5 hora, prima o botão h novamente enquanto o tempo no visor estiver a piscar.
 - Se não realizar qualquer ação durante 2 minutos, o aparelho reverterá para o modo de espera.
10. Tem a opção de utilizar o temporizador com este programa (consultar TEMPORIZADOR).
11. Prima o botão .
12. O visor iniciará a contagem decrescente.
13. No final do tempo de cozedura, o aparelho entrará no modo de “aquecimento”.
14. A luz  acende-se.
15. Prima o botão . Abra a tampa. Retire os alimentos.

IOGURTE

Cultura de iogurte

Pode utilizar 5, 10, 15, 20, 25, 30 ml (2 colheres de sopa) de:

- iogurte activo natural – deve ser fresco (opte por um prazo de validade extenso). Marcas diferentes fornecerão resultados diferentes.

iogurte confeccionado anteriormente.

- As bactérias enfraquecem ao longo do tempo, por isso só poderá realizar este processo 10 vezes antes de utilizar uma cultura nova.





Cultura de iogurte liofilizado encontrada numa farmácia ou loja de produtos naturais

- Caso as instruções na embalagem da cultura difiram das deste guia, siga as instruções da embalagem.



Leite



- É necessário 1 litro de leite.
- Leite gordo criará iogurte mais denso do que leite magro.
- Para o tornar ainda mais denso, poderá adicionar 8 colheres de sopa de leite em pó ao leite líquido.
- Pode ainda utilizar leite em pó reconstituído ou leite evaporado em lata.

Confeccionar iogurte





1. É necessário eliminar as bactérias presentes no leite para evitar que compitam com as bactérias da cultura de iogurte.
2. Enquanto aquece o leite, aguarde que a cultura de iogurte atinja a temperatura ambiente.
3. Abra a tampa.
4. Use o programa A VAPOR (DOURAR/SALTEAR/AMACIAR/FERVER) para aquecer o leite para o ponto imediatamente antes da fervura.
5. Deixe o leite aquecer até começar a borbulhar nos rebordos.
6. Aguarde que o leite arrefeça até se encontrar entre 37°C e 45°C.
7. Misture a cultura de iogurte no leite.
8. Deverão ser muito bem misturados ou o iogurte formará caroços.
9. Feche a tampa.
10. Use o botão  para seleccionar  no menu.
11. Escolha o tempo de cozedura. O tempo predefinido é de 8 horas.
12. Só poderá utilizar os botões h e min enquanto o tempo no visor estiver a piscar.
13. Use o botão min para mover o visor e visualizar as opções (10, 15, 20, 25, 5, 10, 15, 20, 25, 30, 35, 40, 45, 50 e 55).
14. Use o botão h para mover o visor e visualizar as opções (6, 7, 8, 9 e 10).
15. Para anular a programação de 10 hora, prima o botão h novamente enquanto o tempo no visor estiver a piscar.
- Se não realizar qualquer ação durante 2 minutos, o aparelho reverterá para o modo de espera.
16. Tem a opção de utilizar o temporizador com este programa (consultar TEMPORIZADOR).
17. Prima o botão .
18. O visor iniciará a contagem decrescente.
19. No final do tempo de cozedura, o aparelho entrará no modo de espera.
20. Não manterá o iogurte quente.
21. Prima o botão . Abra a tampa. Retire os alimentos.

PÃO



1. Descongele massa congelada completamente antes de a usar.
2. Não cozinhe mais de 500 g de alimentos (aprox.) de uma só vez.
3. Limpe o recipiente com óleo alimentar.
4. Coloque a massa no recipiente.
5. Feche a tampa.
6. Use o botão  para seleccionar  no menu.
7. Escolha o tempo de cozedura. O tempo predefinido é de 3 horas.
8. Só poderá utilizar os botões h e min enquanto o tempo no visor estiver a piscar.
9. Use o botão min para mover o visor e visualizar as opções (10, 15, 20, 25, 5, 10, 15, 20, 25, 30, 35, 40, 45, 50 e 55).
10. Use o botão h para mover o visor e visualizar as opções (1, 2, 3, 4, 5 e 6).
11. Para anular a programação de 6 hora, prima o botão h novamente enquanto o tempo no visor estiver a piscar.
- Se não realizar qualquer ação durante 2 minutos, o aparelho reverterá para o modo de espera.

12. Tem a opção de utilizar o temporizador com este programa (consultar TEMPORIZADOR).
13. Prima o botão .
14. O visor iniciará a contagem decrescente.
15. No final do tempo de cozedura, o aparelho entrará no modo de "aquecimento".
16. A luz  acende-se.
17. Prima o botão . Abra a tampa. Retire os alimentos.



PEIXE

1. Esfregue os alimentos com óleo alimentar na totalidade.
2. Esfregue os temperos na superfície dos alimentos.
3. Coloque uma colher de sopa de óleo alimentar no recipiente.
4. Coloque os alimentos no recipiente.
5. Feche a tampa.
6. O tempo depende do tamanho dos alimentos.
7. Não cozinhe mais de 500 g de alimentos (aprox.) de uma só vez.
8. Sugerimos tempos de cozedura de 10 minutos por 100 g de peso.
9. Use o botão  para selecionar  no menu.
10. Escolha o tempo de cozedura. O tempo predefinido é de 20 minutos.
11. Só poderá utilizar os botões h e min enquanto o tempo no visor estiver a piscar.
12. Use o botão min para mover o visor e visualizar as opções (10, 15, 20, 25, 5, 10, 15, 20, 25, 30, 35, 40, 45, 50 e 55).
13. Se quiser cozinhar durante 1 hora, prima o botão h.
14. Para anular a programação de 1 hora, prima o botão h novamente enquanto o tempo no visor estiver a piscar.
 - Se não realizar qualquer ação durante 2 minutos, o aparelho reverte para o modo de espera.
15. Quando tiver programado o tempo, prima .
16. O visor iniciará a contagem decrescente.
17. No final do tempo de cozedura, o aparelho entrará no modo de "aquecimento".
18. A luz  acende-se.
19. É preferível remover os alimentos assim que estiverem cozinhados para evitar que sequem.
20. Prima o botão . Abra a tampa. Retire os alimentos.

A VAPOR

1. Encha o recipiente de água fria até à marca 6.
2. Coloque o cesto sobre o topo da cuba e deite os alimentos no cesto.
3. Para uma confeção uniforme, corte os alimentos e pedaços de tamanho semelhante.
4. No caso das ervilhas, ou qualquer coisa que se separe ou caia na água, faça um embrulho com uma folha de alumínio.
5. Tenha cuidado ao retirar a folha de alumínio. Use uma pega ou umas tenazes.
6. Feche a tampa.
7. Use o botão  para selecionar  no menu.
8. Escolha o tempo de cozedura. O tempo predefinido é de 30 minutos.
 - Estes deverão cozinhar dentro do tempo predefinido:

Alimento (fresco)	Quantidade
Feijão verde	200g
Couves de bruxelas	200g
Cenouras (rodelas)	200g
Batatas (esquartejado)	400g
Brócolos	200g
Couve	1 Quarto
Maçarocas de milho	2

9. Só poderá utilizar os botões h e min enquanto o tempo no visor estiver a piscar.
10. Use o botão min para mover o visor e visualizar as opções (5, 10, 15, 20, 25, 30, 35, 40, 45, 50 e 55).
11. Use o botão h para mover o visor e visualizar as opções (1 e 2).
12. Para anular a programação de 2 hora, prima o botão h novamente enquanto o tempo no visor estiver a piscar.
 - Se não realizar qualquer ação durante 2 minutos, o aparelho reverterá para o modo de espera.
13. Tem a opção de utilizar o temporizador com este programa (consultar TEMPORIZADOR).
14. Prima o botão .
15. O visor iniciará a contagem decrescente.
16. No final do tempo de cozedura, o aparelho entrará no modo de “aquecimento”.
17. A luz  acende-se.
18. É preferível remover os alimentos assim que estiverem cozinhados para evitar que fiquem empapados.
19. Prima o botão . Abra a tampa. Retire os alimentos.

DOURAR/SALTEAR/AMACIAR/FERVER

- Poderá usar o programa A VAPOR  na sua programação predefinida, com a tampa aberta, como uma panela de temperatura elevada durante 5, 10, 15, 20, 25, 30 minutos antes de cozinhar com outro programa.
- Utilize-o com um pouco de óleo para dourar a carne e os legumes, para saltear, amaciar cebolas, aipo, alho francês, etc.
- Utilize-o com água ou caldo para preaquecer líquidos de confeção.
- Quando muda para o programa principal, o aparelho é aquecido e alguns ou todos os ingredientes já estarão no interior do recipiente.
- Não terá de lavar a panela que teria utilizado durante a preparação.



PORRIDGE/RISOTTO



Use o copo de medida para colocar o cereal (arroz, aveia, cevada, etc.) dentro do recipiente.

Porridge

- Utilize a escala do lado direito, dentro do recipiente, que exibe marcas de ½ a 1½.
- Não encha acima da marca **max**.

Congee





- Utilize a escala do centro, dentro do recipiente, que exibe marcas de 1 a 3.
 - Não encha acima da marca **max**.
1. Encha o recipiente com água até ao número correspondente ao número de copos de cereal.
 2. Feche a tampa.
 3. Use o botão  para selecionar  no menu.
 4. Escolha o tempo de cozedura. O tempo predefinido é de 1 hora.
 5. Só poderá utilizar os botões h e min enquanto o tempo no visor estiver a piscar.
 6. Use o botão min para mover o visor e visualizar as opções (5, 10, 15, 20, 25, 30, 35, 40, 45, 50 e 55).

7. Use o botão **h** para mover o visor e visualizar as opções (1, 2, 3 e 4).
8. Para anular a programação de 4 hora, prima o botão **h** novamente enquanto o tempo no visor estiver a piscar.
 - Se não realizar qualquer ação durante 2 minutos, o aparelho reverterá para o modo de espera.
9. Tem a opção de utilizar o temporizador com este programa (consultar TEMPORIZADOR).
10. Prima o botão .
11. O visor iniciará a contagem decrescente.
12. No final do tempo de cozedura, o aparelho entrará no modo de “aquecimento”.
13. A luz  acende-se.
14. Prima o botão . Abra a tampa. Retire os alimentos.



Risotto

Siga a receita mostrada posteriormente nesta brochura.









BOLO

1. Descongele massa congelada completamente antes de a usar.
2. Não encha o recipiente mais do que cerca de metade.
3. Limpe o recipiente com óleo alimentar.
4. Coloque a massa no recipiente.
5. Feche a tampa.
6. Use o botão  para selecionar  no menu.
7. Escolha o tempo de cozedura. O tempo predefinido é de 40 minutos.
8. O tempo predefinido é de 40 minutos.
9. Só poderá utilizar os botões **h** e **min** enquanto o tempo no visor estiver a piscar.
10. Use o botão **min** para mover o visor e visualizar as opções (5, 10, 15, 20, 25, 30, 35, 40, 45, 50 e 55).
11. Use o botão **h** para mover o visor e visualizar as opções (1 e 2).
12. Para anular a programação de 2 hora, prima o botão **h** novamente enquanto o tempo no visor estiver a piscar.
 - Se não realizar qualquer ação durante 2 minutos, o aparelho reverterá para o modo de espera.
13. Quando tiver programado o tempo, prima .
14. O visor iniciará a contagem decrescente.
15. No final do tempo de cozedura, o aparelho entrará no modo de “aquecimento”.
16. A luz  acende-se.
17. É preferível remover os alimentos assim que estiverem cozinhados para evitar que fiquem empapados.
18. Prima o botão . Abra a tampa. Retire os alimentos.

AQUECIMENTO

- Se quiser utilizar a função de aquecimento após um programa que não é compatível com a função, quando o único elemento exibido no visor for a luz  intermitente, prima .
- Prima  para sair desta função.

TEMPORIZADOR

- Poderá usar o temporizador de atraso com os programas sopa , iogurte , pão , vapor  e porridge .
 - Realize esta ação imediatamente após ter programado o tempo de cozedura e antes de premir iniciar .
1. Prima o botão . A luz  acende-se.
 2. Decida quando quer que os alimentos estejam prontos.
 3. Por exemplo, se neste momento forem 14:00 h e quiser que estejam prontos às 21:00 h, deverá programar o tempo para 7 horas.
 4. Use os botões **h** e **min** para regular a hora e os minutos.
 5. Prima o botão .

CUIDADOS E MANUTENÇÃO







1. Desligue o aparelho da corrente elétrica e aguarde que arrefeça.
2. Desligue a máquina da tomada de corrente e depois retire o conector da entrada de alimentação do aparelho.
3. Com a tampa fechada, agarre o topo do filtro e retire-o da tampa. (FIG. A).
4. Vire-o ao contrário para expor as marcas na extremidade frontal.
5. Segure o bloqueio da tampa do filtro e rode o resto do filtro na direção do cadeado aberto  (FIG. B).
6. Prima as patilhas na parte inferior da tampa interior, e puxe-a para fora do aparelho (FIG. C)
7. Lave à mão as peças removíveis.
8. Limpe todas as superfícies com um pano limpo e húmido.
9. Não coloque nenhuma parte do aparelho na máquina de lavar loiça.
10. Remonte o filtro e volte a colocá-lo na tampa.
11. Volte a colocar a tampa interior na tampa.









RECICLAGEM







Para evitar problemas ambientais e de saúde devido a substâncias perigosas, os aparelhos e baterias recarregáveis e não recarregáveis com um destes símbolos não deverão ser eliminados com o lixo doméstico normal. Elimine sempre os produtos elétricos e eletrónicos e, quando aplicável, as baterias recarregáveis e não recarregáveis, no ponto de reciclagem/recolha oficial apropriado.

RECEITAS

	colher de sopa (15ml)
	colher de chá (5ml)
g	gramas
ml	mililitros
	copo de medida
	haste (aipo)
	punhado
	ovo, médio (53-63 g)

	pitada
	molho
	raminho
	dente(s)
	lata
	jarro
	saqueta (7 g)
	ovo, grande (63-73 g)











CHILLI DE LEGUMES E CUSCUZ

1	cebola vermelha, picada
1	cebola grande, picada
2 	dentes de alho, descascados e picados
1	pimento vermelho, sem sementes e picado
1	pimento amarelo, sem sementes e picado
1	pimento laranja, sem sementes e picado
1 	coentros em pó
1 	de concentrado de tomate
850 ml	caldo de legumes
2 	molho de tomate picante
120-140 ml	cuscuz





para servir:

queijo ralado
pequeno molho de coentros, picados

COZEDURA LENTA

1 	de azeite
1 	feijões manteiga
1 	feijões cannellini
1 	jalapeños verdes
1 	feijões vermelhos
1 	tomates aos pedaços
2 	cominhos em pó
1 	açúcar
2 	malagueta moída
2 	orégãos secos

natas azedas

Abra a tampa. Adicione o óleo. Seleccione  no menu e prima . Adicione a cebola e o alho. Cozinhe até as cebolas ficarem macias. Coe os feijões e adicione-os. Reserve os cuscuz. Adicione os restantes ingredientes. Prima  duas vezes para parar o programa. Feche a tampa. Seleccione . Adicione os cuscuz 30 minutos antes de a cozedura terminar. Se a cozedura já terminou, seleccione  no menu e cozinhe cerca de 20 minutos adicionais. Sirva numa tigela com um punhado de queijo, um pouco de natas azedas e uma pitada de coentros frescos. Para um chilli vegetariano clássico, não coloque os cuscuz.

IOGURTE CASEIRO





1200 ml leite

100 ml iogurte

opção de sabores

50 g mistura de bagas de verão congeladas

1 colher mel

Abra a tampa. Adicione o leite. Selecione  no menu e prima . Deixe o leite aquecer até começar a borbulhar nos rebordos. Prima  duas vezes para parar o programa. Aguarde que o leite arrefeça até se encontrar entre 37°C e 45°C. Misture o iogurte no leite. Deverão ser muito bem misturados ou o iogurte formará caroços. Feche a tampa. Selecione  no menu e prima . Aguarde o programa terminar. Coloque o iogurte no frigorífico para arrefecer completamente. Aqueça as bagas gentilmente num tacho. Adicione o mel. Quando as bagas começarem a amolecer, remova do fogão, deixe arrefecer e, em seguida, misture no iogurte. Se quiser armazenar o iogurte, terá de esterilizar os jarros que for utilizar. Aqueça-os no forno a 100°C durante 10 minutos. O iogurte mantém-se conservado no frigorífico até 2 semanas.

IOGURTE





CHILLI DE VACA DE NOVA IORQUE ARDENTE

450 g carne de vaca estufado
3 dentes de alho, descascados e picados
2 colheres cominhos em pó
1 colher pimenta de caiena
1 colher paprica fumada/chipotle em pó
1 pimento verde
1 sal
1 folhas de manjeriço, picadas grosseiramente

1 colher de azeite
2 cebola, picada
2 colheres malagueta moída
2 colheres molho de tomate
2 tomates
1 louro
1 colher pimenta preta
1 colher feijões vermelhos

GUISADO





Abra a tampa. Adicione o óleo. Selecione  no menu e prima . Corte a carne, os tomates e o pimento em pedaços comestíveis. Doure a carne e, em seguida, remova-a. Adicione a cebola, o alho e todas as ervas. Cozinhe até as cebolas ficarem macias. Adicione a carne. Reserve os feijões. Adicione os restantes ingredientes. Prima  duas vezes para parar o programa. Feche a tampa. Selecione . Adicione os feijões 30 minutos antes de a cozedura terminar. Se a carne ainda estiver um pouco rija no final do programa, adicione um copo de água e acione o programa da carne para 30 minutos adicionais.

TAGINE DE PEIXE MARROQUINO

2 dentes de alho, descascados e picados
1 pimento vermelho, sem sementes e picado
2 tomates aos pedaços
1 colher gengibre em pó
1 pau de canela
120 ml vinho branco
120 ml caldo de peixe
675 g peixe (bacalhau/hadoque/salmão)
1 pequeno molho de coentros, picados

1 cebola, picada
2 aipo, picado
1 colher cominhos em pó
1 colher curcuma
1 colher pasta harissa
1 colher de concentrado de tomate
1 limão
1 azeitonas verdes
sal e pimenta

PEIXE





Reserve os coentros. Abra a tampa. Adicione os restantes ingredientes. Feche a tampa. Selecione  no menu e prima . Cozinhe até o peixe formar lascas (40-60 minutos). Prima  duas vezes para parar o programa. Adicione os coentros. Ajuste o tempero e sirva. Esta receita fica ótima com cuscuz.

SOPA DE JARRETE DE PORCO E ERVILHAS PARTIDAS

1150 ml caldo de galinha
225 g ervilhas partidas
1 aipo, picado
1 colher tomilho, picado finamente
1 jarrete de porco



COZEDURA LENTA

1 cebola, picada finamente
1 cenoura, picada
2 alho (esmagado)
1 louro
pimenta preta

Abra a tampa. Adicione o caldo. Selecione  no menu e prima . Deixe ferver, mexendo frequentemente. Coza em lume brando por 10 minutos. Adicione os restantes ingredientes. Prima  duas vezes para parar o programa. Feche a tampa. Selecione . Aguarde o programa terminar. Remova o jarrete de porco. Descarte a pele e os ossos. Corte a carne em cubos. Descarte a folha de louro. Esmague as ervilhas partidas com a extremidade de uma colher de pau. Adicione a carne. Ajuste o tempero e sirva. Paraíso numa tigela!



BOLO DE BROWNIE DE CHOCOLATE

BOLO 

170 g	manteiga sem sal	3	
340 g	açúcar	1	 essência de baunilha
170 g	pó de cacau	1	 sal
110 g	pedaços de chocolate de leite	75 g	farinha simples







para servir:



gelado de baunilha (opcional)

Derreta a manteiga num tacho em lume brando. Revista o recipiente com folha de alumínio untada com manteiga. Bata a manteiga derretida, o açúcar, o cacau em pó, a farinha, os ovos, a baunilha e o sal num prato. Envolve os pedaços de chocolate. Coloque a massa sobre a folha no interior do recipiente. Feche a tampa. Selecione  no menu. Programe o tempo de cozedura para 1 hora e 30 minutos. Prima o botão . O bolo deverá estar firme nos rebordos e ligeiramente mole no centro. Sirva o bolo quente, com gelado por cima.

SALMÃO COM TEMPERO PICANTE

PEIXE 







2	filetes de salmão (com pele)	1	 de azeite
1	 colorau	1	 malagueta moída
$\frac{1}{2}$	 cominhos em pó	1	 sal e pimenta
1	 açúcar amarelo suave	1	limão

Misture a paprika, o pó de chilli, os cominhos, o açúcar, o sal e a pimenta. Espalhe sobre os filetes de salmão. Abra a tampa. Adicione o óleo. Selecione  no menu e prima . Aguarde alguns minutos para o óleo aquecer. Adicione os filetes com a pele para baixo. Feche a tampa. Esta é uma excelente combinação para fritar e cozinhar peixe a vapor, e ainda obter uma pele estaladiça. Sirva com um gomo de limão. Uma refeição deliciosa e leve.

GUISADO IRLANDÊS (STEW) COM DUMPLINGS DE QUEIJO DE CABRA

GUISADO 





para o stew:

1.8 kg	pá de borrego (cozinhada)	1	 de azeite
250 g	entremeada	3	 alho (esmagado)
950 ml	caldo de borrego		sal e pimenta
1	cebola grande, picada	2	cenouras, picadas
2	 aipo, picado	2	 rosmaninho picado
2	 de concentrado de tomate	1	 farinha de milho

para os dumplings:

100 g	farinha com fermento	1	 fermento
50 g	banha	1	 sal
75 ml	água	1	 salsa seca
40 g	queijo de cabra (suave)	1	 tomilho seco
1	 manjerona seca	1	 pimenta preta

para o stew:

Remova a carne do osso. Corte a carne e o bacon em pedaços comestíveis. Abra a tampa. Selecione  no menu e prima . Adicione o caldo. Deixe ferver, mexendo frequentemente. Coza em lume brando por 10 minutos. Transfira o caldo para um jarro. Adicione o óleo. Adicione a cebola e refogue até ficar macia. Adicione a carne, o alho, as ervas e outros legumes e cozinhe durante 5 minutos. Adicione o caldo. Adicione o puré de tomate. Prima  duas vezes para parar o programa. Feche a tampa. Selecione .

para os dumplings:

Misture todos os ingredientes à mão. Divida a mistura em 6 bolas. Deixe repousar por 20 minutos.

para terminar:



Crie uma pasta suave com a farinha de milho e um pouco de água numa chávena. Abra a tampa 30 minutos antes de a cozedura terminar. Misture a pasta no guisado. Adicione os dumplings. Feche a tampa. Aguarde o programa terminar e sirva em seguida. Uma tigela fabulosa de comida aconchegante!

- Se não tiver borrego cozinhado, poderá usar borrego cru com o programa de cozedura lenta em vez do programa de guisado e, em seguida, continuar a partir do momento dos dumplings.

ALCACHOFRA A VAPOR

VAPOR 

1 	dentes de alho, descascados e picados	2	alcachofras
	raminhos de ervas (estragão, menta, salsa, tomilho)	1	limão

Corte o limão em fatias. Corte cada alcachofra pelo caule, separando a parte inferior do fruto. Corte o quarto superior de cada alcachofra. Descarte quaisquer folhas danificadas. Esfregue as superfícies cortadas com uma fatia de limão. Coloque as fatias de limão no cesto. Adicione os raminhos de ervas. Adicione o alho. Coloque a alcachofra por cima. Encha com água até ao nível 2 na escala do lado esquerdo, dentro do recipiente. Coloque o cesto por cima do recipiente. Feche a tampa. Seleccione  no menu e prima . As alcachofras estão cozidas quando as folhas exteriores forem removidas com facilidade. Sirva quente ou frio com um molho de vinagrete. Fantástico!







REFEIÇÃO NUM SÓ RECIPIENTE DE CEVADA PEROLADA E FEIJÃO BORLOTTI

 GUISADO

1 	de azeite	1 	feijões borlotti
175 g	cevada perolada	1	cebola, picada finamente
1 	tomates aos pedaços	1 	de concentrado de tomate
1000 ml	caldo de legumes	2 	salsa (picada)
125 ml	vinho tinto seco		sal e pimenta

para servir:



óleo de chilli picante (opcional)

Abra a tampa. Seleccione  no menu e prima . Adicione o caldo. Deixe ferver, mexendo frequentemente. Coza em lume brando por 10 minutos. Transfira o caldo para um jarro. Adicione o óleo. Adicione a cebola e refogue até ficar macia. Adicione o vinho e cozinhe durante alguns minutos. Adicione a cevada perolada e misture até começar a adquirir a tonalidade do vinho. Coe os feijões e adicione-os. Adicione os tomates. Adicione o caldo. Prima  duas vezes para parar o programa. Feche a tampa. Seleccione . Abra a tampa 30 minutos antes de a cozedura terminar. Verifique a quantidade de líquido no recipiente. Adicione 150 ml de água quente, se necessário. Feche a tampa. Aguarde o programa terminar. Sirva com pão estaladiço fresco e um pouco de óleo de chilli picante.



PUDIM ESPONJA COM XAROPE

VAPOR 

115 g	manteiga	2	
100 g	açúcar branco refinado	1/4 	essência de baunilha
175 g	farinha com fermento	2 	leite
4 	golden syrup		





Bata os ovos numa tigela. Bata a manteiga e o açúcar numa tigela até obter um creme. Junte gradualmente os ovos, depois a baunilha e por fim a farinha. Misture o leite. Unte uma tigela de ir ao forno de 1200 ml. Coloque o xarope na parte inferior da tigela de ir ao forno e coloque a mistura por cima. Cubra com papel manteiga e, em seguida, com papel de alumínio e ate o topo com um fio. Abra a tampa. Coloque a tigela de ir ao forno no interior do recipiente no aparelho. Adicione água a ferver o suficiente no recipiente do aparelho para alcançar 3 cm abaixo do limite superior da tigela de ir ao forno. Feche a tampa. Seleccione  no menu. Programe o tempo de cozedura para 1 hora e 30 minutos. Prima o botão . Aguarde o programa terminar. Inverta para um prato e sirva quente. Este é um pudim excelente para qualquer altura do ano!!

RISOTTO DE BETERRABA PREPARADO NO ROBOT DE COZINHA PORRIDGE/ RISOTTO

400 g	beterraba	2 	de azeite
250 g	arroz arbori/risotto	1	cebola, picada finamente
2 	dentes de alho, descascados e picados	250 ml	vinho branco
900 ml	caldo de legumes / caldo de galinha	1 	tomilho, picado finamente

para terminar:

100 ml	iogurte	1 	salsa (picada)
1 	manteiga		

Abra a tampa. Selecione  no menu e prima . Adicione o caldo. Deixe ferver, mexendo frequentemente. Coza em lume brando por 10 minutos. Transfira o caldo para um jarro. Prima  duas vezes para parar o programa. Selecione  no menu e prima . Deixe a repousar para aquecer. Descasque a beterraba e corte-a em cubos de 1 cm. Coloque a beterraba, o alho e a cebola no recipiente. Cozinhe até as cebolas ficarem macias. Misture o arroz. Feche a tampa e cozinhe durante 3-4 minutos. Abra a tampa. Misture o vinho. Feche a tampa e cozinhe durante 3-4 minutos. Abra a tampa. Adicione o tomilho. Adicione o caldo. Feche a tampa. Aguarde o programa terminar. Verifique o arroz: não deverá estar nem demasiado cozido nem demasiado duro. Se ainda não estiver cozinhado, adicione um pouco de água e cozinhe durante mais alguns minutos. Misture a manteiga: é o que dá aquele toque especial ao risotto. Sirva com uma colherada de iogurte e polvilhe com salsa. Esta receita é ótima como entrada ou como um almoço leve.

PORRIDGE

2 	aveia
1 1/4 	sal



para servir:

açúcar amarelo

PORRIDGE/RISOTTO

	água
2 	açúcar

leite / natas

Abra a tampa. Adicione a aveia, o sal e o açúcar. Encha com água até ao nível 1/2 na escala do lado direito, dentro do recipiente. Feche a tampa. Selecione  no menu e prima . Aguarde o programa terminar. Sirva com leite ou natas. Polvilhe com açúcar amarelo escuro. Se desejar, poderá adicionar alperces secos picados ou passas em metades (sem as sementes) 15 minutos antes do final do tempo de cozedura. O porridge que restar poderá ser preservado no frigorífico até 2 dias e reaquecido.

PORRIDGE COM AMÊNDOAS

1/2 	flocos de aveia
120 ml	leite
1 	canela moída



para servir:

golden syrup

PORRIDGE/RISOTTO





	água
3 	coco ralado

amêndoas picadas



Abra a tampa. Adicione a aveia, a canela, o coco e o leite. Encha com água até ao nível 1/2 na escala do lado direito, dentro do recipiente. Feche a tampa. Selecione  no menu e prima . Aguarde o programa terminar. Coloque um fio de golden syrup e polvilhe com amêndoas picadas por cima.

PÃO BRANCO

1 	golden syrup
320 ml	leite
500 g	farinha para pão branco

Abra a tampa. Adicione o leite. Selecione  no menu e prima . Deixe o leite aquecer até começar a borbulhar nos rebordos. Transfira o leite para um jarro. Prima  duas vezes para parar o programa. Aguarde que o leite arrefeça até se encontrar entre 37°C e 45°C. Derreta a manteiga num tacho em lume brando. Misture a farinha e o sal numa tigela. Adicione o fermento, a manteiga e o xarope. Adicione o leite e bata até formar uma bola. Se a mistura ficar muito peganhenta, adicione um pouco de farinha. Cubra e deixe a repousar num local morno durante 10 minutos. Bata novamente. Cubra e deixe a repousar num local morno durante 10 minutos. Abra a tampa. Selecione  no menu e prima . Feche a tampa. Abra a tampa 30 minutos antes de a cozedura terminar. Vire o pão ao contrário. Isto ajudará a conferir ao topo do pão um pouco de cor e textura estaladiça. Aguarde o programa terminar. Sirva com manteiga.

PÃO

1 	manteiga
1 	fermento seco
1 	sal

PÃO DE BICARBONATO



1 mistura de pão de bicarbonato
350 ml água

manteiga

Abra a tampa. Unte o recipiente com manteiga. Seleccione no menu. Feche a tampa. Programe o tempo de cozedura para 2 horas e 15 minutos. Prima o botão . Deixe a repousar para aquecer. Coloque a mistura de pão de bicarbonato numa tigela. Adicione a água. Misture à mão até formar uma bola. Abra a tampa. Coloque a massa no recipiente. Divida a massa em quartos com uma espátula de plástico. Feche a tampa. Abra a tampa 30 minutos antes de a cozedura terminar. Vire o pão ao contrário. Isto ajudará a conferir ao topo do pão um pouco de cor e textura estaladiça. Aguarde o programa terminar. Arrefeça numa grelha. Sirva com manteiga com sal sozinho ou a acompanhar uma refeição.

ARROZ SABOROSO



2 arroz
1 cubo de caldo (legumes)
1 pimento vermelho, sem sementes e picado
1 curcuma

água
2 cenouras, picadas
2 aipo, picado
1 ervilhas (opcional)

Abra a tampa. Coloque o arroz no recipiente. Encha com água até ao nível 2 na escala do lado esquerdo, dentro do recipiente. Esmague o cubo de caldo e misture-o na água. Adicione os restantes ingredientes. Feche a tampa. Seleccione . Aguarde o programa terminar e sirva em seguida. Se o arroz ainda não estiver bem cozinhado, deixe-o repousar alguns minutos com a tampa fechada, para cozinhar a vapor.

SOPA GRANDE DE TOMATE



1 cebola, picada
1 tomates aos pedaços
1 pimento vermelho, sem sementes e picado
550 ml caldo de galinha
1 mistura de ervas secas

1 de azeite
2 tomates aos pedaços
2 batatas
1 de concentrado de tomate
1 pimenta preta

Abra a tampa. Adicione o caldo. Seleccione no menu e prima . Deixe ferver, mexendo frequentemente. Coza em lume brando por 10 minutos. Transfira o caldo para um jarro. Prima duas vezes para parar o programa. Descasque e corte as batatas em cubos. Seleccione no menu e prima . Adicione o óleo. Adicione a cebola e o pimento doce. Cozinhe até as cebolas ficarem macias. Adicione o caldo. Adicione os restantes ingredientes. Feche a tampa. Aguarde o programa terminar. Ajuste os temperos. Sirva com pão estaladiço.

SOPA DE CHOURIÇO, COUVE E MAÇÃ



¼ chouriço, picado finamente
1 maçã
2 aipo, picado
¼ repolho, picado finamente
2 dentes de alho, descascados e picados
1 sal
850 ml caldo de legumes







1 cebola, picada finamente
2 cenouras, picadas
2 tomates aos pedaços
1 de concentrado de tomate
1 pimenta de caiena
1 pimenta preta



Abra a tampa. Seleccione no menu e prima . Salteie o chouriço durante 2 minutos. Adicione a cebola e o alho. Cozinhe até as cebolas ficarem macias. Descasque a maçã, retire as sementes e pique-a. Adicione os restantes ingredientes. Prima duas vezes para parar o programa. Feche a tampa. Seleccione no menu e prima . Aguarde o programa terminar. Esta é uma sopa fantástica e se a deixar no frigorífico durante a noite, o sabor será ainda melhor.





GALINHA COM TOMATES E COGUMELOS



CARNE 

2	peitos de frango, desossados e sem pele	1 	de azeite
450 g	cogumelos marron, picados	1 	tomates aos pedaços
2 	dentes de alho, descascados e picados	1 	molho de tomate
1 	molho Worcestershire	1 	orégãos secos
	sal e pimenta		









Abra a tampa. Selecione  no menu e prima . Adicione o óleo. Tempere os peitos de frango com sal e pimenta e coloque-os no recipiente. Vire a carne para revestir ambos os lados. Adicione o alho e os cogumelos. Cozinhe durante 3-4 minutos, virando a galinha uma vez. Adicione os tomates, o molho Worcestershire, o molho de tomate e os orégãos. Continue a cozinhar, virando a galinha mais uma vez. Verifique se a galinha está completamente cozinhada. Sirva com massa, batatas ou arroz. Uma refeição rápida e saborosa com ingredientes que costuma ter na despensa.





COSTELETAS ASSADAS EM CERVEJA PRETA (STOUT) COM ÁCER E SOJA CARNE

1 kg	costeletas de porco	1	cebola, picada
350 ml	cerveja Guinness/stout	1 	de azeite
140 ml	caldo de carne de vaca/porco	60 ml	xarope de ácer / mel
3 	dentes de alho, descascados e picados	2 	molho de soja escuro

Abra a tampa. Selecione  no menu. Adicione o óleo. Programe o tempo de cozadura para 1 hora e 45 minutos. Prima o botão . Adicione as costeletas e doure-as durante 5 minutos, virando-as ocasionalmente. Remova as costeletas. Adicione a cebola e o alho. Cozinhe até as cebolas ficarem macias. Volte a colocar as costeletas no recipiente. Misture a Guinness, o caldo, o xarope de ácer e o molho de soja. Feche a tampa. Aguarde o programa terminar. Ajuste o tempero e sirva. Uma excelente entrada ou parte de um almoço variado.

REFEIÇÃO NUM SÓ RECIPIENTE: PEITO DE VACA COZEDURA LENTA

1 kg	peito de vaca	2 	de concentrado de tomate
2 	dentes de alho, descascados e picados	2 	louro
50 g	chouriço, cortado às rodelas	2	cenouras
2	cebolas vermelhas, picadas	3 	aipo
600 ml	caldo de carne de vaca	2 	rosmaninho picado
2 	mistura de ervas secas	1 	tomates aos pedaços
6-8	batatas (pequenas)		sal e pimenta
2 	molho Worcestershire		

Deixe a pele nas batatas. Corte as batatas, cenouras e aipo em pedaços. Tempere o peito de vaca com sal e pimenta. Abra a tampa. Selecione  no menu e prima . Adicione o caldo. Deixe ferver, mexendo frequentemente. Coza em lume brando por 10 minutos. Transfira o caldo para um jarro. Salteie o chouriço durante 2 minutos. Adicione a carne. Doure completamente. Adicione as cebolas, o alho, as batatas, o aipo e as cenouras. Se tiver outros legumes de raiz que precise de utilizar, também os poderá adicionar. Cozinhe até as cebolas ficarem macias. Adicione o caldo. Adicione os restantes ingredientes. Prima  duas vezes para parar o programa. Selecione . Aguarde o programa terminar e sirva em seguida. Cozinhar durante 8 horas não fará qualquer mal, mas estará provavelmente pronto a comer ao fim de 5 horas.

Læs vejledningen og behold den til senere brug. Lad den følge med apparatet, hvis det overdrages til andre. Fjern al emballage før brug.

VIGTIGE SIKKERHEDSINSTRUKTIONER

Følg altid de grundlæggende sikkerhedsregler, herunder:

Dette apparat kan anvendes af børn fra 8 år og derover og personer hvis fysiske, sansemæssige eller mentale evner er nedsat, eller personer uden den fornødne erfaring, hvis de er blevet instrueret/har været under opsyn og forstår de forbundne farer. Børn må ikke lege med apparatet. Rengøring og vedligeholdelse må ikke foretages af børn, medmindre de er over 8 år og holdes under opsyn. Apparatet og ledningen skal holdes uden for rækkevidden af børn under 8 år.

Hvis stik eller ledning er beskadiget, skal de udskiftes med en særlig anordning, som fås hos fabrikanten eller dennes servicecenter.

 Brug ikke dette apparat i nærheden af et badekar, brusebad, håndvask eller andre beholdere med vand.

 Forket brug af apparatet kan forårsage tilskadekomst.

 Apparatets overflader kan blive meget varme. Eftervarme holder overfladerne varme efter brug.

- Læg ikke frosset kød eller fjerkræ i apparatet – optø helt inden brug.
- Tilbered altid kød, fjerkræ og halvfabrikata heraf (hakket kød, burgerbøffer, etc.), til kødsaften er klar. Tilbered fisk indtil kødet er ugenomsigtigt hele vejen igennem.
- Forsøg ikke at tilberede mad i kogerens base – kun i den aftagelige skål.
- Undgå at fylde skålen til over max.
- Undlad at tildække apparatet eller anbringe noget oven på det.
- Tag stikket ud af stikkontakten, tag derefter apparatets stik ud af dets strømningang.
- Tag apparatet ud af stikket, når det ikke er i brug.
- Anvend ikke andet tilbehør eller andre dele end de medfølgende.
- Anvend ikke apparatet til andre formål end dem, der er beskrevet i denne brugsanvisning.
- Undlad at anvende apparatet, hvis det er beskadiget eller ikke fungerer korrekt.

KUN TIL PRIVAT BRUG

TEGNINGER

- | | |
|-------------------|--------------|
| 1. Kontrolpanel | 5. Målebæger |
| 2. Låg | 6. Kurv |
| 3. Lågets lås | 7. Skål |
| 4. Indvendigt låg | 8. Stik |



FORBEREDELSE

1. Anbring apparatet på et stabilt, plant og varmebestandigt underlag.
2. Brug ikke apparatet i nærheden af eller under gardiner, hylder og skabe eller noget andet som kan tage skade af damp, som slipper ud.
3. Hav ovenhandsker (eller et viskestykke) ved hånden og en bordskåner eller en middagstallerken til at stille skålen på efter tilberedning.





4. Sæt skålen ned i kogerens.
5. Drej skålen en kvart omgang hver vej for at sikre, at skålens bund har god kontakt med elementet.



RIS

1. Mål ris af i målebægeret og kom ris i skålen.
2. Tilsæt ikke mere end 10 kopper ris.
3. Brug skalaen længst til venstre, inden i skålen, som har markeringer fra 2 til 10.
4. Fyld vand i skålen op til det tal, som svarer til antal kopper af ris, du har tilsat.
5. Luk låget.
6. Tryk på -knappen. Knappen vil lyse.
7. De yderste segmenter på displayet blinker, mens maden varmes op.
8. Displayet viser derefter den resterende tilberedningstid (13 minutter) og begynder at tælle ned.
9. Når tilberedningstiden er slut, slår apparatet over på "hold varm"-funktionen.  lyset vil lyse.
10. Åbn låget.
11. Tag skålen op og sæt den på en bordskåner eller en middagstallerken.
12. Tryk på -knappen.
13. Vend og bland risen med paletkniven, så al dampen slipper væk.
14. Nogle gange vil et lag ris, som er i kontakt med skålen lægge sig som en skorpe.
15. Hvis du ikke vil have den, kan du tage den op med paletkniven, når du har serveret risen.



SIMRERETTER



1. Brun kød og grønsager (se "BRUNE/SAUTERE/BLØDSTEGE/KOGE").
2. Bring væsken til retten i kog (se "BRUNE/SAUTERE/BLØDSTEGE/KOGE").
3. De faste ingredienserne kommer i skålen og dernæst tilsættes væske til retten.
4. Luk låget.
5. Tryk på -knappen. Knappen vil lyse.
6. Displayet viser nu 8 timer og tæller ned.
7. Når tilberedningstiden er slut, slår apparatet over på "hold varm"-funktionen.  lyset vil lyse.
8. Tryk på -knappen. Åbn låget. Tag maden af apparatet.

STUVNINGER





1. Brun kød og grønsager (se "BRUNE/SAUTERE/BLØDSTEGE/KOGE").
2. Bring væsken til retten i kog (se "BRUNE/SAUTERE/BLØDSTEGE/KOGE").
3. De faste ingredienserne kommer i skålen og dernæst tilsættes væske til retten.
4. Luk låget.
5. Tryk på -knappen. Knappen vil lyse.
6. Displayet viser 1 timer og tæller ned.
7. Når tilberedningstiden er slut, slår apparatet over på "hold varm"-funktionen.  lyset vil lyse.
8. Tryk på -knappen. Åbn låget. Tag maden af apparatet.

KØD

1. Maden gnides ind overalt i madlavningsolie.
2. Hvis der bruges krydderier, gnides de ind i madens overflade.
3. Kom en spiseskefuld madlavningsolie i skålen.
4. Læg maden ned i skålen.
5. Luk låget.
6. Tiden afhænger af stykkernes størrelse.
7. Tilbered ikke mere end cirka 500 g mad ad gangen.
8. Vi forslår tilberedningstider på 10 minutter + 10 minutter pr. 100 g oksekød.
9. Svinekød og fjerkræ skal koges i mindst 5, 10, 15, 20, 25, 30 minutter.
10. Med -knappen vælges  i menuen.

11. Vælg dernæst tilberedningstiden. Standardtiden er 20 minutter.
12. Du kan kun bruge knapperne h og min, mens tiden på displayet blinker.
13. Tryk på min-knappen for at få displayet til at skifte minuttal (10, 15, 20, 25, 5, 10, 15, 20, 25, 30, 35, 40, 45, 50 og 55).
14. Tryk på h-knappen, hvis du ønsker at indstille tilberedningstiden til 1 time.
15. For at fortryde 1 times indstillingen trykkes på h-knappen igen, mens displayet blinker.
 - Hvis du ikke foretager nogen indstillinger i 2 minutter, går apparatet på standby.
16. Tryk på , når du har indstillet tiden.
17. Displayet begynder nu at tælle ned.
18. Når tilberedningstiden er slut, slår apparatet over på "hold varm"-funktionen.  lyset vil lyse.
19. Tryk på -knappen. Åbn låget. Tag maden af apparatet.

SUPPE

1. Brun kød og grønsager (se "BRUNE/SAUTERE/BLØDSTEGE/KOGE").
2. De faste ingredienserne kommer i skålen og dernæst tilsættes væske til retten.
3. Luk låget.
4. Med -knappen vælges  i menuen.
5. Vælg dernæst tilberedningstiden. Standardtiden er 1 time.
6. Du kan kun bruge knapperne h og min, mens tiden på displayet blinker.
7. Tryk på min-knappen for at få displayet til at skifte minuttal (10, 15, 20, 25, 5, 10, 15, 20, 25, 30, 35, 40, 45, 50 og 55).
8. Tryk på h-knappen for at få displayet til at skifte minuttal (1, 2, 3, 4 og 5).
9. For at fortryde 5 times indstillingen trykkes på h-knappen igen, mens displayet blinker.
 - Hvis du ikke foretager nogen indstillinger i 2 minutter, går apparatet på standby.
10. Du har mulighed for at bruge timeren på dette program (se TIMER).
11. Tryk på -knappen.
12. Displayet begynder nu at tælle ned.
13. Når tilberedningstiden er slut, slår apparatet over på "hold varm"-funktionen.  lyset vil lyse.
14. Tryk på -knappen. Åbn låget. Tag maden af apparatet.

YOGHURT

Yoghurtkultur

Du kan bruge 5, 10, 15, 20, 25, 30ml (2 spiseskeer):

- Yoghurt natural med levende bakteriekulturer – den skal være frisk (lang tid til holdbarhedsdatoen udløber). Forskellige mærker vil give forskellige resultater.

Yoghurt du før har lavet.

- Bakterierne svækkes med tiden, så du kan kun gøre dette 10 gange, inden du skal bruge en ny kultur. Frysetørret yoghurtkultur fra apoteket eller materialisten.
- Hvis anvisningerne på pakken med kultur modsiger denne vejledning, skal du følge anvisningerne på pakken.





Mælk

- Du skal brug 1 liter mælk.
- Sødmælk giver tykkere yoghurt end skummetmælk.
- For at gøre yoghurten endnu tykkere, kan du tilsætte op til 8 spiseskefulde pulverbælg til den flydende mælk.
- Du kan også bruge oprørt pulverbælg, eller langtidsholdbar mælk på dåse.





Yoghurtfremstilling

1. Du skal dræbe bakterierne i mælken for at undgå, at de konkurrerer med bakterierne i yoghurtkulturen.
2. Mens du varmer mælken, skal yoghurtkulturen op på stuetemperatur.
3. Åbn låget.







- Opvarm mælken på DAMPE (BRUNE/SAUTERE/BLØDSTEGE/KOGE) -programmet til lige under kogepunktet.
- Lad mælken varme, indtil den begynder at boble i kanterne.
- Lad mælken køle af til mellem 37°C og 45°C.
- Rør yoghurtkulturen i mælken.
- Det skal blandes omhyggeligt, ellers bliver din yoghurt klumpet.
- Luk låget.
- Med -knappen vælges  i menuen.
- Vælg dernæst tilberedningstiden. Standardtiden er 8 timer.
- Du kan kun bruge knapperne h og min, mens tiden på displayet blinker.
- Tryk på min-knappen for at få displayet til at skifte minuttal (10, 15, 20, 25, 5, 10, 15, 20, 25, 30, 35, 40, 45, 50 og 55).
- Tryk på h-knappen for at få displayet til at skifte minuttal (6, 7, 8, 9 og 10).
- For at fortryde 10 times indstillingen trykkes på h-knappen igen, mens displayet blinker.
- vis du ikke foretager nogen indstillinger i 2 minutter, går apparatet på standby.
- Du har mulighed for at bruge timeren på dette program (se TIMER).
- Tryk på -knappen.
- Displayet begynder nu at tælle ned.
- Når tilberedningstiden er slut, går apparatet på standby.
- Det holder ikke yoghurten varm.
- Tryk på -knappen. Åbn låget. Tag maden af apparatet.

BRØD



- Frossen dej skal tøs helt op inden brug.
- Tilbered ikke mere end cirka 500 g mad ad gangen.
- Skålen pensles med madlavningsolie.
- Dejen lægges i skålen.
- Luk låget.
- Med -knappen vælges  i menuen.
- Vælg dernæst tilberedningstiden. Standardtiden er 3 timer.
- Du kan kun bruge knapperne h og min, mens tiden på displayet blinker.
- Tryk på min-knappen for at få displayet til at skifte minuttal (10, 15, 20, 25, 5, 10, 15, 20, 25, 30, 35, 40, 45, 50 og 55).
- Tryk på h-knappen for at få displayet til at skifte minuttal (1, 2, 3, 4, 5 og 6).
- For at fortryde 6 times indstillingen trykkes på h-knappen igen, mens displayet blinker.
- Hvis du ikke foretager nogen indstillinger i 2 minutter, går apparatet på standby.
- Du har mulighed for at bruge timeren på dette program (se TIMER).
- Tryk på -knappen.
- Displayet begynder nu at tælle ned.
- Når tilberedningstiden er slut, slår apparatet over på "hold varm"-funktionen.  lyset vil lyse.
- Tryk på -knappen. Åbn låget. Tag maden af apparatet.

FISK



- Maden gnides ind overalt i madlavningsolie.
- Hvis der bruges krydderier, gnides de ind i madens overflade.
- Kom en spiseskefuld madlavningsolie i skålen.
- Læg maden ned i skålen.
- Luk låget.
- Tiden afhænger af stykkernes størrelse.
- Tilbered ikke mere end cirka 500 g mad ad gangen.
- Vi forslår tilberedningstider på 10 minutter pr. 100 g fisk.
- Med -knappen vælges  i menuen.

10. Vælg dernæst tilberedningstiden. Standardtiden er 20 minutter.
11. Du kan kun bruge knapperne h og min, mens tiden på displayet blinker.
12. Tryk på min-knappen for at få displayet til at skifte minuttal (10, 15, 20, 25, 5, 10, 15, 20, 25, 30, 35, 40, 45, 50 og 55).
13. Tryk på h-knappen, hvis du ønsker at indstille tilberedningstiden til 1 time.
14. For at fortryde 1 times indstillingen trykkes på h-knappen igen, mens displayet blinker.
 - Hvis du ikke foretager nogen indstillinger i 2 minutter, går apparatet på standby.
15. Tryk på , når du har indstillet tiden.
16. Displayet begynder nu at tælle ned.
17. Når tilberedningstiden er slut, slår apparatet over på "hold varm"-funktionen.  lyset vil lyse.
18. Det er bedst at tage maden af apparatet, så snart den er tilberedt for at undgå, at den tørrer ud.
19. Tryk på -knappen. Åbn låget. Tag maden af apparatet.

DAMPE

1. Fyld koldt vand i skålen, op til 6-markeringen.
2. Sæt kurven oven på skålen og læg mad i kurven.
3. En ensartet tilberedning opnås ved at skære al maden i cirka samme størrelse.
4. Ærter eller andet, som vil gå itu eller falde ned i vandet lægges i en pakke af aluminiumsfolie.
5. Vær forsigtig, når du fjerner pakken – brug ovenhandsker eller en plastik pincet/skeer.
6. Luk låget.
7. Med -knappen vælges  i menuen.
8. Vælg dernæst tilberedningstiden. Standardtiden er 30 minutter.
 - Følgende ingredienser bør blive tilberedt inden for standardtiden:

Mad (fersk)	Mængde
Grønne bønner	200g
Rosenkål	200g
Gulerødder (i skiver)	200g
Kartofler (i kvarter)	400g
Broccoli	200g
Kål	Kvart
Majskolber	2

9. Du kan kun bruge knapperne h og min, mens tiden på displayet blinker.
10. Tryk på min-knappen for at få displayet til at skifte minuttal (5, 10, 15, 20, 25, 30, 35, 40, 45, 50 og 55).
11. Tryk på h-knappen for at få displayet til at skifte minuttal (1 og 2).
12. For at fortryde 2 times indstillingen trykkes på h-knappen igen, mens displayet blinker.
 - Hvis du ikke foretager nogen indstillinger i 2 minutter, går apparatet på standby.
13. Du har mulighed for at bruge timeren på dette program (se TIMER).
14. Tryk på -knappen.
15. Displayet begynder nu at tælle ned.
16. Når tilberedningstiden er slut, slår apparatet over på "hold varm"-funktionen.  lyset vil lyse.
17. Det er bedst at tage maden op af apparatet, så snart den er tilberedt for at undgå, at den bliver svampet.
18. Tryk på -knappen. Åbn låget. Tag maden af apparatet.



BRUNE/SAUTERE/BLØDSTEGE/KOGE

- Du kan bruge DAMP -programmet på dets standardindstilling, med låget åbent, som en højtemperaturgyde i 5, 10, 15, 20, 25, 30 minutter, inden tilberedning på et andet program.
- Brug det med en smule olie til brunning af kød og grøntsager, eller til at sautere, blødstege løg, selleri, porrer, etc.
- Brug det med vand eller billion til forvarmning af væske til en ret.
- Når du så skifter til hovedprogrammet, er apparatet varmet op, og nogle af, eller alle ingredienserne, ligger allerede i skålen.
- Du slipper således for at vaske en ekstra gryde af, du ville have brugt til forberedelse.





PORRIDGE (GRØD)/RISOTTO

Brug målebægeret og kom kornprodukt (ris, havregryn, byg, etc.) i skålen.

Porridge (grød)

- Brug skalaen længst til højre, inden i skålen, som har markeringer fra ½ til 1½.
- Undgå at fylde skålen til over **max**.





Congee (asiatisk risgrød)

- Brug den midterste skala, inden i skålen, som har markeringer fra 1 til 3.
 - Undgå at fylde skålen til over **max**.
1. Fyld vand i skålen op til det tal, som svarer til antal kopper af kornprodukt, du har tilsat.
 2. Luk låget.
 3. Med -knappen vælges  i menuen.
 4. Vælg dernæst tilberedningstiden. Standardtiden er 1 time.
 5. Du kan kun bruge knapperne h og min, mens tiden på displayet blinker.
 6. Tryk på min-knappen for at få displayet til at skifte minuttal (5, 10, 15, 20, 25, 30, 35, 40, 45, 50 og 55).
 7. Tryk på h-knappen for at få displayet til at skifte minuttal (1, 2, 3 og 4).
 8. For at fortryde 4 times indstillingen trykkes på h-knappen igen, mens displayet blinker.
 - Hvis du ikke foretager nogen indstillinger i 2 minutter, går apparatet på standby.
 9. Du har mulighed for at bruge timeren på dette program (se TIMER).
 10. Tryk på -knappen.
 11. Displayet begynder nu at tælle ned.
 12. Når tilberedningstiden er slut, slår apparatet over på "hold varm"-funktionen.  lyset vil lyse.
 13. Tryk på -knappen. Åbn låget. Tag maden af apparatet.

Risotto



Følg opskriften, som kommer senere i denne pjece.

KAGE









1. Frossen dej skal tøs helt op inden brug.
2. Undgå at fylde skålen mere en halvt op.
3. Skålen pensles med madlavningsolie.
4. Dejen lægges i skålen.
5. Luk låget.
6. Med -knappen vælges  i menuen.
7. Vælg dernæst tilberedningstiden. Standardtiden er 40 minutter.
8. Standardtiden er 40 minutter.
9. Du kan kun bruge knapperne h og min, mens tiden på displayet blinker.
10. Tryk på min-knappen for at få displayet til at skifte minuttal (5, 10, 15, 20, 25, 30, 35, 40, 45, 50 og 55).
11. Tryk på h-knappen for at få displayet til at skifte minuttal (1 og 2).
12. For at fortryde 2 times indstillingen trykkes på h-knappen igen, mens displayet blinker.
- Hvis du ikke foretager nogen indstillinger i 2 minutter, går apparatet på standby.
13. Tryk på , når du har indstillet tiden.
14. Displayet begynder nu at tælle ned.
15. Når tilberedningstiden er slut, slår apparatet over på "hold varm"-funktionen.  lyset vil lyse.

16. Det er bedst at tage maden op af apparatet, så snart den er tilberedt for at undgå, at den bliver svampet.
17. Tryk på -knappen. Åbn låget. Tag maden af apparatet.

HOLD VARM

- Hvis du ønsker at bruge hold varm-funktionen efter et program, som ikke allerede anvender denne, skal du – når det eneste, der vises på displayet er den blinkende -lampe – trykke på .
- Tryk på  for at forlade denne funktion.

TIMEREN

- Du kan bruge forsinket timer på suppe , yoghurt , brød , damp  og porridge -programmerne.
- Gør dette umiddelbart efter indstilling af tilberedningstiden, og inden du trykker på start :
 1. Tryk på -knappen.  lyset vil lyse.
 2. Bestem, hvornår du vil have maden klar.
 3. Hvis klokken f.eks. er 14:00 nu, og du vil have den klar kl. 21:00, skal tiden indstilles til 7 timer.
 4. Brug **h** og **min** knapperne til indstilling af korrekt time og minut.
 5. Tryk på -knappen.

PLEJE OG VEDLIGEHOLDELSE







1. Tag apparatets stik ud og lad det køle af.
2. Tag stikket ud af stikkontakten, tag derefter apparatets stik ud af dets strømledning.
3. Med låget lukket, tages fat øverst på filtret og det lirkes ud af låget. (FIG. A).
4. Vend det om, så markeringerne på forkanten kommer til syne.
5. Hold godt fast i filterlåget og drej resten af filtret hen imod den åbne hængelås  (FIG. B).
6. Tryk på tapperne nederst på det indvendige låg, og tag det af apparatet (FIG.C).
7. Vask de aftagelige dele af i hånden.
8. Tør alle overflader af med en ren, fugtig klud.
9. Ingen af delene tåler opvaskemaskine.
10. Saml igen filtret og sæt det tilbage i låget.
11. Sæt det indvendige låg tilbage i låget.

GENBRUG



For at undgå miljø- og sundhedsmæssige problemer forårsaget af farlige stoffer, må apparater og genopladelige og ikke-genopladelige batterier, der er mærket med et af disse symboler, ikke kasseres sammen med almindeligt husholdningsaffald. Udtjente elektriske og elektroniske produkter samt genopladelige og ikke-genopladelige batterier fra produkterne skal afleveres på en godkendt genbrugsplads eller indsamlingssted.

OPSKRIFTER

	spiseskefuld (15ml)
	teskefuld (5ml)
g	gram
ml	milliliter
	målebæger
	stilk/bundt (bladselleri)
	håndfuld
	æg, medium (53-63 g)

	knivspids
	bundt
	dusk
	fed
	dåse
	krukke
	brev (7 g)
	æg, sort (63-73 g)

HJEMMELAVET YOGHURT

YOGHURT





1200 ml mælk

100 ml yoghurt

smagsvariant







50 g frosne blandede sommerbær

1  honning





Åbn låget. Mælken tilsættes. Vælg  i menuen og tryk på . Lad mælken varme, indtil den begynder at boble i kanterne. Tryk to gange på  for at stoppe programmet. Lad mælken køle af til mellem 37°C og 45°C. Yoghurten røres i mælken. Det skal blandes omhyggeligt, ellers bliver din yoghurt klumpet. Luk låget. Vælg  i menuen og tryk på . Vent indtil programmet er færdigt. Yoghurten stilles i køleskabet til den er kølet helt af. Bærrene opvarmes nænsomt i en gryde. Honningen tilsættes. Når bærrene begynder at falde sammen pga. varmen, køles de af og blandes sammen med yoghurten. Hvis du vil opbevare yoghurten, skal krukkerne, du ønsker at bruge først steriliseres. Varm krukkerne i ovnen ved 100°C i 10 minutter. Yoghurten kan holde sig i op til 2 uger i køleskabet.

FYRIG NY CHILIRET MED OKSEKØD

STUVNINGER





450 g oksekød til gryderetter
3  hvidløg, pillede og hakkede
2  stødt spidskommen
1  cayennepeber
1  røget paprika/chipotle-pulver
1 grøn peberfrugt
1  salt
1  basilikumblade, grofthakkede

1  olivenolie
2  løg, hakkede
2  chilipulver
2  tomatsauce
2  tomater
1  laurbærblad
1  sort peber
1  kidneybønner

Åbn låget. Tilsæt olien. Vælg  i menuen og tryk på . Oksekød, tomater og peberfrugter skæres i mundrette stykker. Kødet brunes og tages af. Løg, hvidløg og alle krydderurterne tilsættes. Løgene tilberedes indtil de er bløde. Tilsæt kød. Bønnerne stilles til side. Resten af ingredienserne tilsættes. Tryk to gange på  for at stoppe programmet. Luk låget. Vælg . Bønnerne tilsættes 30 minutter, inden tilberedningstiden er slut. Hvis kødet stadig ikke er helt mørt ved slutningen af programmet, tilsættes en kop vand og kødprogrammet køres i yderligere 30 minutter.

CHILIRET MED GRØNSAGER OG COUSCOUS

SIMRERETTER

1 rød løg, hakket
1 stort løg, hakket
2  hvidløg, pillede og hakkede
1 rød peberfrugt, udkernet og hakket
1 gul peberfrugt, udkernet og hakket
1 orange peberfrugt, udkernet og hakket
1  stødt koriander
1  tomatpuré
850 ml grøntsagsbouillon
2  stærk tomatsauce
120-140 ml couscous





1  olivenolie
1  smørbønner
1  cannellini-bønner
1  grønne jalapenos
1  kidneybønner
1  hakkede tomater
2  stødt spidskommen
1  sukker
2  chilipulver
2  tørret oregano

serveres med:

revet ost









creme fraiche



lille bundt koriander, hakket

Åbn låget. Tilsæt olien. Vælg  i menuen og tryk på . Tilsæt løg og hvidløg. Løgene tilberedes indtil de er bløde. Bønnerne afdrypes og tilsættes. Couscousen stilles til side. Resten af ingredienserne tilsættes. Tryk to gange på  for at stoppe programmet. Luk låget. Vælg . Couscousen tilsættes 30 minutter, inden tilberedningstiden er slut. Hvis tilberedningstiden allerede er slut vælges  i menuen og retten tilberedes i yderligere 20 minutter. Serveres i en skål med en håndfuld ost, et stænk cremefraiche og et drys frisk koriander. En klassisk vegetarisk chili opnås ved at undlade at tilsætte couscous.

MAROKKANSK FISKETAGINE

FISK 





2 	hvidløg, pillede og hakkede	1	løg, hakkede
1	rød peberfrugt, udkernet og hakket	2 	bladselleri, hakket
2	hakkede tomater	1 	stødt spidskommen
1 	stødt ingefær	1 	gurkemeje
1	kanelstang	1 	harissa-pasta
120 ml	hvidvin	1 	tomatpuré
120 ml	fiskebouillon	1	citron
675 g	fisk (torsk/kuller/laksefillet)	1 	grønne oliven
1	lille bundt koriander, hakket		salt og peber

Koriander lægges til side. Åbn låget. Resten af ingredienserne tilsættes. Luk låget. Vælg  i menuen og tryk på . Fisken tilberedes indtil fiskekødet begynder at falde fra hinanden (40-60 minutter). Tryk to gange på  for at stoppe programmet. Koriander tilsættes. Smages til og serveres. Couscous passer fremragende til denne ret.

SUPPE MED FLÆKKEDE ÆRTER OG SKINKEBEN

SIMRERETTER 

1150 ml	kyllingefond	1	løg, fint hakket
225 g	flækkede ærter	1	gulerod, hakket
1 	bladselleri, hakket	2 	hvidløg (knust)
1 	timian, fint hakket	1 	laurbærblad
1	skinkeben		sort peber



Åbn låget. Tilsæt bouillon. Vælg  i menuen og tryk på . Bring i kog, rør rundt. Lad suppen simre i 10 minutter. Resten af ingredienserne tilsættes. Tryk to gange på  for at stoppe programmet. Luk låget. Vælg . Vent indtil programmet er færdigt. Skinkebenet tages op. Skin og ben kasseres. Kødet skæres i tern. Laurbærbladet kasseres. De flækkede ærter moses med bagsiden af en træske. Tilsæt kød. Smages til og serveres.

En himmelsk suppe!

LAKS MED KRYDRET OVERSIDE

FISK 

2	laksefileter (med skind)	1 	olivenolie
1 	paprika	1 	chilipulver
1/2 	stødt spidskommen	1 	salt og peber
1 	brun farin	1	citron

Paprika, chilipulver, spidskommen, sukker, salt og peber blandes. Drysses over laksefileterne. Åbn låget. Tilsæt olien. Vælg  i menuen og tryk på . Vent et par minutter, indtil olien er varm. Fileterne lægges i olien med skindsiden nedad. Luk låget. Dette er en fantastisk kombination af dampning og stegning af fiskestykker, og så bliver skindet sprødt. Serveres med en citronbåd. Et lækkert let måltid.



CHOKOLADEBROWNIE-KAGE

KAGE 

170 g	usaltet smør	3	
340 g	sukker	1 	vaniljeessens
170 g	kakaopulver	1 	salt
110 g	mælkechokoladedråber	75 g	hvedemel

serveres med:







vaniljeis (valgfrit)

Smelt smørret i en gryde ved lav varme. Skålen fores med stanniol smurt med smør. Smeltet smør, sukker, kakaopulver, mel, æg, vanilje og salt piskes sammen i en skål. Chokoladedråberne vendes i. Dejes hældes ned i stanniolen inden i skålen. Luk låget. Vælg  på menuen. Indstil tilberedningstiden til 1 time og 30 minutter. Tryk på -knappen. Kagen skal være fast rundt langs kanterne og en smule klæbrig i midten. Kagen serveres varm med is på toppen.

IRSK STEW (STUVNING) MED GEDEOSTE-DUMPLINGS

STUVNINGER 





til stew:

1.8 kg	lammeskulder (allerede tilberedt)	1 	olivenolie
250 g	stribet bacon	3 	hvidløg (knust)
950 ml	lammebouillon		salt og peber
1	stort løg, hakket	2	gulerødder, hakkede
2 	bladselleri, hakket	2 	rosmarin, hakket
2 	tomatpuré	1 	majsmel

til dumplings:

100 g	selvhævende mel	1 	bagepulver
50 g	flomme	1 	salt
75 ml	vand	1 	tørret persille
40 g	gedeost (blød)	1 	tørret timian
1 	tørret merian	1 	sort peber

til stew:

Kødet pilles af benet. Kød og bacon skæres i mundrette stykker. Åbn låget. Vælg  i menuen og tryk på . Tilsæt bouillon. Bring i kog, rør rundt. Lad suppen simre i 10 minutter. Bouillonon hældes over i en kande. Tilsæt olien. Tilsæt løg og sauter indtil de bliver bløde. Kød, hvidløg, krydderurter og resten af grønsagerne tilsættes og tilberedes i 5 minutter. Tilsæt bouillon. Tomatpuré tilsættes. Tryk to gange på  for at stoppe programmet. Luk låget. Vælg .

til dumplings:

Alle ingredienserne blandes med hænderne. Formes til 6 boller. Lad hvile i 200 sekunder.

til slut:

Rør en lind pasta af majsmel og en smule vand i en kop. 30 minutter før tilberedningstiden er slut, åbnes låget. Majspastaen røres i gryderetten. Dumplings tilsættes. Låget lukkes. Vent indtil programmer er færdigt og servér. En fantastisk grydefuld komfort-mad!

- Hvis du ikke har allerede tilberedt lammekød, kan du bruge rått lammekød på simreprogrammet i stedet for stuvningsprogrammet - og derefter følge opskriften fra dumplings-punktet.

DAMPET ARTISKOK



DAMP 



1 	hvidløg, pillede og hakkede	2	artiskokhoveder
	Krydderurtesduske (estragon, mynte, persille, timian)	1	citron

Citronen skæres i skiver. Artiskokkernes stokke skæres over lige under bunden af hovedet. Den øverste fjerdedel af artiskokkerne skæres af. Eventuelt beskadigede blade kasseres. Skærefladerne gnides med en citronskive. Citronskiverne lægges i kurven. Krydderurtesduske tilsættes. Hvidløg tilsættes. Artiskok lægges ovenpå. Fyld vand op til niveau 2 på skalaen længst til venstre, inden i skålen. Kurven sættes oven på skålen. Luk låget. Vælg  i menuen og tryk på . Artiskokkerne er færdigt tilberedte, når de ydre blade nemt kan trækkes af. Serveres varme eller kolde med vinaigrette. Fantastisk!

PERLEBYG OG BORLOTTI-BØNNE ALT-I-EN-GRYDE





STUVNINGER

1  olivenolie
175 g perlebyg
1  hakkede tomater
1000 ml grøntsagsbouillon
125 ml tør rødvin

1  borlotti-bønner
1 løg, fint hakket
1  tomatpuré
2  persille (hakket)
salt og peber

serveres med:

stærk chiliolie (valgfrit)

Åbn låget. Vælg  i menuen og tryk på . Tilsæt bouillon. Bring i kog, rør rundt. Lad suppen simre i 10 minutter. Bouillon hældes over i en kande. Tilsæt olien. Tilsæt løg og sauter indtil de bliver bløde. Vin tilsættes og retten koger videre i et par minutter. Perlebyg tilsættes - rør rundt indtil det begynder at tage farve af vinen. Bønnerne afdryppes og tilsættes. Tomaterne tilsættes. Tilsæt bouillon. Tryk to gange på  for at stoppe programmet. Luk låget. Vælg . 30 minutter før tilberedningstiden er slut, åbnes låget. Hold øje med væskemængden i skålen. Tilsæt om nødvendigt yderligere 150 ml varmt vand. Luk låget. Vent indtil programmet er færdigt. Serveres med friskbagt sprødt brød og et stærk chiliolie.



SVAMPET SIRUPSBUDDING

DAMP



115 g smør
100 g fintmalet sukker
175 g selvhævende mel
4  lys sirup

2 
¼  vaniljeessens
2  mælk



Æggene piskes sammen i en skål. Smør og sukker piskes cremet i en skål. Tilsæt æggene et efter et, dernæst vanilje og til sidst mel. Mælken røres i. Smør en 1.200 ml ovnfast skål. Siruppen kommer i bunden af den ovnfaste skål og blandingen hældes ovenpå. Dækkes med bagepapir og derefter med stanniol, som strammes til øverst med en snor. Åbn låget. Den ovnfaste skål sættes ned i apparatets skål. Hæld vand i apparatets skål, så det når op til 3 cm under den ovnfaste skåls kant. Luk låget. Vælg  på menuen. Indstil tilberedningstiden til 1 time og 30 minutter. Tryk på -knappen. Vent indtil programmet er færdigt. Skålen vendes på hovedet og buddingen serveres varm. En fantastisk budding hele året!!

SODABRØD

BRØD

1  sodabrød-blanding
350 ml vand



smør





Åbn låget. Skålen smøres med smør. Vælg  på menuen. Luk låget. Indstil tilberedningstiden til 2 timer og 15 minutter. Tryk på -knappen. Lad apparatet forvarme. Hæld sodabrød-blanding i en skål. Tilsæt vandet. Blandes med hænderne til en kugle. Åbn låget. Dejen lægges i skålen. Dejen deles op i kvarte med en plastikspatel. Luk låget. 30 minutter før tilberedningstiden er slut, åbnes låget. Vend brøde. Det vil give brødets overside lidt mere farve og sprødhed. Vent indtil programmet er færdigt. Afkøl på en bagerist. Serveres med saltet smør, alene eller som tilbehør.

HVIDT BRØD

BRØD

1  lys sirup
320 ml mælk
500 g hvedemel

1  smør
1  tørgær
1  salt

Åbn låget. Mælken tilsættes. Vælg  i menuen og tryk på . Lad mælken varme, indtil den begynder at boble i kanterne. Mælken hældes over i en kande. Tryk to gange på  for at stoppe programmet. Lad mælken køle af til mellem 37°C og 45°C. Smelt smørret i en gryde ved lav varme. Mel og salt blandes i en skål. Gær, smør og sirup tilsættes. Mælken tilsættes og dejen æltes til en kugle. Hvis blandingen er meget klæbrig tilsættes lidt mere mel. Skal hvile tildækket på et lunt sted i 10 minutter. Æltes igen. Skal hvile tildækket på et lunt sted i 10 minutter. Åbn låget. Vælg  i menuen og tryk på . Luk låget. 30 minutter før tilberedningstiden er slut, åbnes låget. Vend brøde. Det vil give brødets overside lidt mere farve og sprødhed. Vent indtil programmet er færdigt. Serveres med et godt lag smør.

PORRIDGE (GRØD)

- 2 ☐ havregryn
- 1¼ ✓ salt

serveres med:

farin

Åbn låget. Havregryn, salt og sukker tilsættes. Fyld vand op til niveau 1½ på skalaen længst til højre, inden i skålen. Luk låget. Vælg ☞ i menuen og tryk på ⬇. Vent indtil programmet er færdigt. Serveres med mælk eller fløde. Brødet stænkes med puddersukker. Du kan tilsætte hakkede abrikoser eller halve svesker (uden sten) 15 minutter inden endt tilberedningstid. Porridgerester kan gemmes i køleskabet i 2 dage, og opvarmes.

NØDDEAGTIG GRØD

- ½ ☐ valset havre
- 120 ml mælk
- 1 ✓ stødt kanel

serveres med:

lys sirup

Åbn låget. Havre, kanel, kokos og mælk tilsættes. Fyld vand op til niveau ½ på skalaen længst til højre, inden i skålen. Luk låget. Vælg ☞ i menuen og tryk på ⬇. Vent indtil programmet er færdigt. Stænkes med lys sirup og drysses med finthakkede mandler.

MULTI-COOKER RØDBEDERISOTTO

- 400 g rødbede
- 250 g arbori/risottoris
- 250 ml hvidvin
- 900 ml grøntsagsbouillon / kyllingefond

til slut:

- 100 ml yoghurt
- 1 ✓ smør

Åbn låget. Vælg ☞ i menuen og tryk på ⬇. Tilsæt bouillon. Bring i kog, rør rundt. Lad suppen simre i 10 minutter. Bouillonnen hældes over i en kande. Tryk to gange på ⏏ for at stoppe programmet. Vælg ☞ i menuen og tryk på ⬇. Lad apparatet forvarme. Rødbeden skrælles og skæres i 1 cm store tern. Rødbede, hvidløg og løg lægges i skålen. Løgene tilberedes indtil de er bløde. Risen røres i. Låget lukkes og retten koger videre i 3-4 minutter. Åbn låget. Vinen røres i. Låget lukkes og retten koger videre i 3-4 minutter. Åbn låget. Timian tilsættes. Tilsæt bouillon. Luk låget. Vent indtil programmet er færdigt. Se til risen – den skal have lidt bid, men må ikke være hård. Hvis den ikke er helt klar, tilsættes lidt vand og den koger videre i et par minutter. Smørret røres i – for at give risottoen glans. Serveres med en klat yoghurt og drysses med persille. Lækker som forret eller let frokost.

SMAGFULD RIS

- 2 ☐ ris
- 1 boullionterning (grøntsags)
- 1 rød peberfrugt, udkernet og hakket
- 1 ✓ gurkemeje

Åbn låget. Risen hældes i skålen. Fyld vand op til niveau 2 på skalaen længst til venstre, inden i skålen. Boullionterningen knuses og røres i vandet. Resten af ingredienserne tilsættes. Luk låget. Vælg ☞. Vent indtil programmer er færdigt og servér. Hvis risen ikke er helt klar, koges den videre i et par minutter, med låget lukket, for at dampe den.

PORRIDGE (GRØD)/RISOTTO ☞

- vand
- 2 ✓ sukker

mælk / kaffefløde

PORRIDGE (GRØD)/RISOTTO ☞

- vand
- 3 ✓ tørret kokos

finthakkede mandler

PORRIDGE (GRØD)/RISOTTO ☞

- 2 ✓ olivenolie
- 1 løg, fint hakket
- 2 ☞ hvidløg, pillede og hakkede
- 1 ✓ timian, fint hakket



1 ✓ persille (hakket)



RIS ☞





- vand
- 2 gulerødder, hakkede
- 2 ✓ bladselleri, hakket
- 1 ✓ ærter (valgfrit)

TOMATSUPPE

SUPPE



- 1 løg, hakkede
- 1  hakkede tomater
- 1 rød peberfrugt, udkernet og hakket
- 550 ml kyllingefond
- 1  tørrede krydderurter



- 1  olivenolie
- 2 hakkede tomater
- 2 kartofler
- 1  tomatpuré
- 1  sort peber





Åbn låget. Tilsæt bouillon. Vælg  i menuen og tryk på . Bring i kog, rør rundt. Lad suppen simre i 10 minutter. Bouillonon hældes over i en kande. Tryk to gange på  for at stoppe programmet. Kartoflerne skrælles og skæres i tern. Vælg  i menuen og tryk på . Tilsæt olien. Løg og peberfrugt tilsættes. Løgene tilberedes indtil de er bløde. Tilsæt bouillon. Resten af ingredienserne tilsættes. Luk låget. Vent indtil programmet er færdigt. Smages til med krydderier. Serveres med sprødt brød.

SUPPE MED CHORIZO, KÅL ÆBLE

SUPPE



- ¼ chrizopølse, finthakket
- 1 æble
- 2  bladselleri, hakket
- ¼ grønkål, finthakket
- 2  hvidløg, pillede og hakkede
- 1  salt
- 850 ml grøntsagsbouillon





- 1 løg, fint hakket
- 2 gulerødder, hakkede
- 2 hakkede tomater
- 1  tomatpuré
- 1  cayennepeber
- 1  sort peber



Åbn låget. Vælg  i menuen og tryk på . Chorizoen sautes i 2 minutter. Tilsæt løg og hvidløg. Løgene tilberedes indtil de er bløde. Æblet skrælles, udkernes og skæres i mindre stykker. Resten af ingredienserne tilsættes. Tryk to gange på  for at stoppe programmet. Luk låget. Vælg  i menuen og tryk på . Vent indtil programmet er færdigt. En fantastisk suppe, som får endnu mere smag, hvis den stilles i køleskabet natten over.

KYLLING MED TOMAT OG CHAMPIGNON

KØD

- 2 kyllingebryst uden skind og ben
- 450 g brune champignoner, hakkede
- 2  hvidløg, pillede og hakkede
- 1  Worcestershire sauce
- salt og peber



- 1  olivenolie
- 1  hakkede tomater
- 1  tomat sauce
- 1  tørret oregano



Åbn låget. Vælg  i menuen og tryk på . Tilsæt olien. Kyllingebrysterne krydres med salt og peber og lægges i skålen. Vend kødet for at lukke porerne på begge sider af kødet. Hvidløg og champignoner tilsættes. Tilberedes først i 3-4 minutter, vendes én gang. Tomater, Worcestershiresauce, tomat sauce og oregano tilsættes. Fortsæt nu tilberedningen, vend kyllingen en gang mere. Se efter, om kyllingen er gennemstegt. Serveres med pasta, kartofler eller ris. En hurtig og lækker ret med ingredienser, du har i skabet.

STOUT-BRAISEREDE SVINERIBBEN MED AHORNSIRUP OG SOJA

KØD



- 1 kg svineslagsribben
- 350 ml Guinness / stout
- 140 ml oksekøds-/svinekødsbouillon
- 60 ml ahornsirup / honning

- 1 løg, hakkede
- 1  olivenolie
- 3  hvidløg, pillede og hakkede
- 2  mørk sojasauce





Åbn låget. Vælg  på menuen. Tilsæt olien. Indstil tilberedningstiden til 1 time og 45 minutter. Tryk på -knappen. Ribbenene tilsættes og brunes i 5 minutter – vendes flere gange. Ribbenene tages op. Tilsæt løg og hvidløg. Løgene tilberedes indtil de er bløde. Ribbenene lægges tilbage i skålen. Guinness, bouillon, ahornsirup og sojasauce røres i. Luk låget. Vent indtil programmet er færdigt. Smages til og serveres. En fantastisk forret eller som en del af en frokostbuffet.

SPIDSBRYST ALT-I-EN-GRYDE

SIMRERETTER

1 kg	spidsbryst
2 	hvidløg, pillede og hakkede
50 g	chorizopølse, skiveskåret
2	rødløg, hakkede
600 ml	oksekødsbouillon
2 	tørrede krydderurter
6-8	kartofler (små)
2 	Worchestershire sauce

2 	tomatpuré
2 	laurbærblad
2	gulerødder
3 	selleri
2 	rosmarin, hakket
1 	hakkede tomater
	salt og peber

Lad skrællen være på kartoflerne. Kartofler, gulerødder og bladselleri skæres i stykker. Spidsbrystet kryddres med salt og peber. Åbn låget. Vælg  i menuen og tryk på . Tilsæt bouillon. Bring i kog, rør rundt. Lad suppen simre i 10 minutter. Bouillonens hældes over i en kande. Chorizoen sautes i 2 minutter. Tilsæt kød. Bruner over det hele. Løg, hvidløg, kartofler, bladselleri og gulerødder tilsættes. Hvis du har andre rester af rodfrugter, der skal bruges, kan de også tilsættes. Løgene tilberedes indtil de er bløde. Tilsæt bouillon. Resten af ingredienserne tilsættes. Tryk to gange på  for at stoppe programmet. Vælg . Vent indtil programmer er færdigt og servér. Retten smager fint efter 8 timers tilberedning, men den er sikkert klar allerede efter 5 timer.

Läs bruksanvisningen och spara den för framtida bruk. Låt bruksanvisningen följa med om du överläter apparaten. Ta bort allt förpackningsmaterial före användning.

VIKTIGA SKYDDSÅTGÄRDER

Följ allmänna säkerhetsföreskrifter, däribland följande:

Denna apparat kan användas av barn från 8 års ålder och uppåt och av personer med nedsatt fysisk, sensorisk eller mental förmåga eller med bristande erfarenhet och kunskap, om personerna i fråga är under uppsikt och har fått anvisningar om hur apparaten fungerar och om de har förstått vilka risker som användningen kan medföra. Barn ska inte leka med apparaten. Rengöring och användarunderhåll ska inte utföras av barn, såvida de inte är över 8 år och är under uppsikt. Håll apparat och elkabel utom räckhåll för barn under 8 år.

Om kontakten eller sladden är skadad måste den skadade delen bytas ut mot en specialdel från tillverkaren eller serviceombudet.

 Använd inte denna apparat nära badkar, dusch, handfat eller andra behållare för vatten.

 Felaktig användning av apparaten kan orsaka skada.

 Apparats utsida blir varm. Eftervärmern gör att utsidorna fortfarande är varma efter avslutad användning.

- Lägg inte ned djupfryst kött eller fågel i apparaten – tina ingredienserna fullständigt före tillagningen.
- Tillaga alla kött- och fågelprodukter, även styckade och malda delar, tills kötsaften tränger igenom. Tillaga fisk tills köttet är fast.
- Tillaga ingenting i apparatens hölje – all mat ska tillagas i den avtagbara skålen.
- Fyll inte över maximal markering (max).
- Täck inte över apparaten och lägg inte heller något ovanpå den.
- Dra först ut stickkontakten från vägguttaget och dra därefter ut kontakten på apparaten (efter användning).
- Dra ut nätsladden när grillen inte används.
- Använd bara tillbehör och övrig utrustning som företaget tillhandahåller.
- Använd inte apparaten för några andra ändamål än sådana som beskrivs i denna bruksanvisning.
- Använd inte apparaten om den är skadad eller fungerar dåligt.

ENDAST FÖR HUSHÅLLSBRUK

BILDER

- | | |
|------------------|------------|
| 1. Kontrollpanel | 5. Kopp |
| 2. Lock | 6. Korg |
| 3. Locklås | 7. Skål |
| 4. Innerlock | 8. Kontakt |



FÖRBEREDELSE

1. Ställ apparaten på en fast, jämn och värmetålig yta.
2. Använd inte apparaten nära eller under gardiner, hyllor, skåp eller något annat som skulle kunna





- skadas av utströmmande ånga.
3. Ha grillvantar eller en handduk i närheten samt ett värmefåligt underlägg eller en tallrik att sätta skålen på.
 4. Placera skålen inne i apparaten.
 5. Vrid skålen ett kvarts varv i vardera riktningen för att vara säker på att skålens botten har kontakt med elementet.
-



RIS

1. Använd koppen för att hälla riset i skålen.
 2. Använd inte mer än 10 koppar ris.
 3. Använd skalan till vänster inuti skålen, som är markerad från 2 till 10
 4. Fyll skålen med vatten upp till det nummer som motsvarar antal koppar ris som används.
 5. Stäng locket.
 6. Tryck på -knappen. Knapplampan lyser.
 7. De yttre segmenten på displayen blinkar medan maten värms upp.
 8. Displayen kommer sedan att visa återstående tillagningstid (13 minuter) och räkna ned.
 9. Vid slutet av tillagningstiden kommer apparaten att sättas i "varmhållningsläge".
 10. Signallampan  tänds.
 11. Öppna locket.
 12. Flytta skålen och ställ den på ett värmefåligt underlägg eller en tallrik.
 13. Tryck på -knappen.
 14. Använd köksspaden för att röra om och blanda riset så att all ånga avdunstar.
 15. Ibland får riset i skålens botten en knaprig yta.
 16. Du kan också välja att ta bort den knapriga ytan med hjälp av köksspaden när du har hållt upp riset.
-

LÅNGKOK





1. Bryn kött och grönsaker (se "BRYNA/FRÄSA/MJUKSTEKA/KOKA").
 2. Koka tillagningsvätskan (se "BRYNA/FRÄSA/MJUKSTEKA/KOKA").
 3. Lägg de fasta ingredienserna i skålen och tillsätt tillagningsvätskan.
 4. Stäng locket.
 5. Tryck på -knappen. Knapplampan lyser.
 6. Displayen kommer att visa 8 timmar och räkna ned.
 7. Vid slutet av tillagningstiden kommer apparaten att sättas i "varmhållningsläge".
 8. Signallampan  tänds.
 9. Tryck på -knappen. Öppna locket. Ta ut maten.
-

SJUDNING

1. Bryn kött och grönsaker (se "BRYNA/FRÄSA/MJUKSTEKA/KOKA").
 2. Koka tillagningsvätskan (se "BRYNA/FRÄSA/MJUKSTEKA/KOKA").
 3. Lägg de fasta ingredienserna i skålen och tillsätt tillagningsvätskan.
 4. Stäng locket.
 5. Tryck på -knappen. Knapplampan lyser.
 6. Displayen kommer att visa 1 timme och räkna ned.
 7. Vid slutet av tillagningstiden kommer apparaten att sättas i "varmhållningsläge".
 8. Signallampan  tänds.
 9. Tryck på -knappen. Öppna locket. Ta ut maten.
-





KÖTT

1. Gnid maten jämnt med matlagningsoljan.
2. Gnid in eventuella kryddor över hela matens yta.
3. Häll en matsked olja i skålen.

- Lägg maten i skålen.
- Stäng locket.
- Tillagningstiden beror på hur stora delar som tillagas.
- Tillaga inte mer än ca 500 gram mat åt gången.
- Vi föreslår tillagningstider på 10 minuter + 10 minuter per 100 gram kött.
- Tillaga inte fläskkött eller fågel i mindre än 5, 10, 15, 20, 25, 30 minuter.
- Använd knappen  för att välja  i menyn.
- Välj tillagningstiden. Standardtiden är 20 minuter.
- Du kan bara använda h- och min-knapparna när displaytiden blinkar.
- Använd min-knappen för att bläddra mellan alternativen i displayen (10, 15, 20, 25, 5, 10, 15, 20, 25, 30, 35, 40, 45, 50 och 55).
- Om du vill tillaga i en 1 timme, tryck h-knappen.
- För att ta bort 1-timmeställningen, tryck på h-knappen igen medan displaytiden blinkar.
 - Om du inte gör någonting under 2 minuter kommer apparaten att återgå till standbyläge.
- När du har ställt in tiden, tryck .
- Displayen räknar ned.
- Vid slutet av tillagningstiden kommer apparaten att sättas i "varmhållningsläge".
- Signallampan  tänds.
- Tryck på -knappen. Öppna locket. Ta ut maten.



SOPPA

- Bryn kött och grönsaker (se "BRYNA/FRÄSA/MJUKSTEKA/KOKA").
- Lägg de fasta ingredienserna i skålen och tillsätt tillagningsvätskan.
- Stäng locket.
- Använd knappen  för att välja  i menyn.
- Välj tillagningstiden. Standardtiden är 1 timme.
- Du kan bara använda h- och min-knapparna när displaytiden blinkar.
- Använd min-knappen för att bläddra mellan alternativen i displayen (10, 15, 20, 25, 5, 10, 15, 20, 25, 30, 35, 40, 45, 50 och 55).
- Använd h-knappen för att bläddra mellan alternativen i displayen (1, 2, 3, 4 och 5).
- För att ta bort 5-timmeställningen, tryck på h-knappen igen medan displaytiden blinkar.
 - Om du inte gör någonting under 2 minuter kommer apparaten att återgå till standbyläge.
- Man kan också använda timern med detta program (se TIMER).
- Tryck på -knappen.
- Displayen räknar ned.
- Vid slutet av tillagningstiden kommer apparaten att sättas i "varmhållningsläge".
- Signallampan  tänds.
- Tryck på -knappen. Öppna locket. Ta ut maten.

YOGHURT

Yoghurtkultur

Man kan använda 5, 10, 15, 20, 25, 30 ml (2 matskedar) av:

- Naturell levande yoghurt – det är viktigt att den är färsk, så kontrollera utgångsdatum. Olika märken ger olika resultat.

Yoghurt som du gjort tidigare.

- Man kan använda samma yoghurtkultur 10 gånger. Därefter avtar effekten och man bör använda en ny startkultur.

Frystorkad yoghurtkultur från apotek eller hälsokostaffär.





- Följ instruktionerna för den kultur du köper om de skulle avvika från dessa anvisningar.

Mjölk





- Det behövs 1 liter mjölk
- Mjölk med hög fetthalt ger tjockare yoghurt än mjölk med låg fetthalt.

- För att få yoghurten ännu tjockare kan man tillsätta upp till 8 matskedar mjölkpulver i mjölken.
- Man kan också använda en blandning av mjölkpulver och vatten (rekonstituerad mjölk) eller kondenserad mjölk.

Göra yoghurt





1. Mjölkbakterierna måste förstöras för att de inte ska konkurrera med bakterierna i yoghurtkulturen.
2. Se till att yoghurtkulturen har rumstemperatur och värm upp mjölken.
3. Öppna locket.
4. Använd programmet för ÅNGKOKNING (BRYNA/FRÄSA/MJUKSTEKA/KOKA) för att värma upp mjölken tills den nästa når kokpunkten.
5. Värm mjölken tills den börjar bubbla runt kanterna.
6. Låt mjölken svalna till mellan 37°C och 45°C.
7. Rör ned yoghurtkulturen i mjölken.
8. Blanda noggrant för att undvika klumpar.
9. Stäng locket.
10. Använd knappen  för att välja  i menyn.
11. Välj tillagningstiden. Standardtiden är 8 timmar.
12. Du kan bara använda h- och min-knapparna när displaytiden blinkar.
13. Använd min-knappen för att bläddra mellan alternativen i displayen (10, 15, 20, 25, 5, 10, 15, 20, 25, 30, 35, 40, 45, 50 och 55).
14. Använd h-knappen för att bläddra mellan alternativen i displayen (6, 7, 8, 9 och 10).
15. För att ta bort 10-timmeställningen, tryck på h-knappen igen medan displaytiden blinkar.
- Om du inte gör någonting under 2 minuter kommer apparaten att återgå till standbyläge.
16. Man kan också använda timern med detta program (se TIMER).
17. Tryck på -knappen.
18. Displayen räknar ned.
19. Vid slutet av tillagningstiden kommer apparaten att sättas i standbyläge.
20. Den kommer inte att hålla yoghurten varm.
21. Tryck på -knappen. Öppna locket. Ta ut maten.

BRÖD

1. Tina fryst deg ordentligt innan den används.
2. Tillaga inte mer än ca 500 gram mat åt gången.
3. Gnid skålen med matlagingsolja.
4. Placera degen i skålen.
5. Stäng locket.
6. Använd knappen  för att välja  i menyn.
7. Välj tillagningstiden. Standardtiden är 3 timmar.
8. Du kan bara använda h- och min-knapparna när displaytiden blinkar.
9. Använd min-knappen för att bläddra mellan alternativen i displayen (10, 15, 20, 25, 5, 10, 15, 20, 25, 30, 35, 40, 45, 50 och 55).
10. Använd h-knappen för att bläddra mellan alternativen i displayen (1, 2, 3, 4, 5 och 6).
11. För att ta bort 6-timmeställningen, tryck på h-knappen igen medan displaytiden blinkar.
- Om du inte gör någonting under 2 minuter kommer apparaten att återgå till standbyläge.
12. Man kan också använda timern med detta program (se TIMER).
13. Tryck på -knappen.
14. Displayen räknar ned.
15. Vid slutet av tillagningstiden kommer apparaten att sättas i "varmhållningsläge".
16. Signallampan  tänds.
17. Tryck på -knappen. Öppna locket. Ta ut maten.



FISK

1. Gnid maten jämnt med matlagingsoljan.

2. Gnid in eventuella kryddor över hela matens yta.
3. Håll en matsked olja i skålen.
4. Lägg maten i skålen.
5. Stäng locket.
6. Tillagningstiden beror på hur stora delar som tillagas.
7. Tillaga inte mer än ca 500 gram mat åt gången.
8. Vi föreslår tillagningstider på 10 minuter per 100 g vikt.
9. Använd knappen  för att välja  i menyn.
10. Välj tillagningstiden. Standardtiden är 20 minuter.
11. Du kan bara använda h- och min-knapparna när displaytiden blinkar.
12. Använd min-knappen för att bläddra mellan alternativen i displayen (10, 15, 20, 25, 5, 10, 15, 20, 25, 30, 35, 40, 45, 50 och 55).
13. Om du vill tillaga i en 1 timme, tryck h-knappen.
14. För att ta bort 1-timmesinställningen, tryck på h-knappen igen medan displaytiden blinkar.
 - Om du inte gör någonting under 2 minuter kommer apparaten att återgå till standbyläge.
15. När du har ställt in tiden, tryck .
16. Displayen räknar ned.
17. Vid slutet av tillagningstiden kommer apparaten att sättas i "varmhållningsläge".
18. Signallampnan  tänds.
19. Det är bäst att ta ut maten när den är tillagad, för att förhindra att den torkar ut.
20. Tryck på -knappen. Öppna locket. Ta ut maten.





ÅNGKOKNING

1. Fyll skålen med kallt vatten upp till markeringen 6.
2. Placera korgen uppe på skålen och lägg maten i skålen.
3. Skär ingredienserna i ungefär lika stora delar så allting blir färdigt samtidigt.
4. Gör ett paket av aluminiumfolie och lägg in ärtor och liknande ingredienser som kan mosas sönder eller glida ned i vattnet.
5. Var försiktig när du öppnar paketet efter tillagningen – använd grillvantar eller en tång/sked av plast.
6. Stäng locket.
7. Använd knappen  för att välja  i menyn.
8. Välj tillagningstiden. Standardtiden är 30 minuter.
 - Dessa bör tillagas inom standardtiden:

Mat (färsk)	Kvantitet
Gröna bönor	200g
Brysselkål	200g
Morötter (skivade)	200g
Potatisar (delade i fyra delar)	400g
Broccoli	200g
Vitkålhuvud	Delat i fyra delar
Majskolvar	2

9. Du kan bara använda h- och min-knapparna när displaytiden blinkar.
10. Använd min-knappen för att bläddra mellan alternativen i displayen (5, 10, 15, 20, 25, 30, 35, 40, 45, 50 och 55).
11. Använd h-knappen för att bläddra mellan alternativen i displayen (1 och 2).
12. För att ta bort 2-timmesinställningen, tryck på h-knappen igen medan displaytiden blinkar.
 - Om du inte gör någonting under 2 minuter kommer apparaten att återgå till standbyläge.
13. Man kan också använda timern med detta program (se TIMER).

- Tryck på -knappen.
- Displayen räknar ned.
- Vid slutet av tillagningstiden kommer apparaten att sättas i "varmhållningsläge".
- Signallampan  tänds.
- Det är bäst att ta ut maten så fort den är klar, för att undvika att den blir svampig.
- Tryck på -knappen. Öppna locket. Ta ut maten.

BRYNA/FRÄSA/MJUKSTEKA/KOKA

- Du kan använda programmet för ÅNGKOKNING  vid dess standardinställning, med locket öppet, som en högtemperaturspanna i 5, 10, 15, 20, 25, 30 minuter, innan du tillagar med ett annat program.
- Använd det med lite olja för att bryna kött och grönsaker, för att fräsa, för att mjuksteka lök, selleri, purjolök, etc.
- Använd det med vatten eller buljong för att värma tillagningsvätskan i förväg.
- När du byter till huvudprogrammet värms apparaten upp och vissa eller alla ingredienser kommer redan att vara i skålen.
- Då behöver du inte diska pannan som du har använt vid förberedelsen.

PORRIDGE (GRÖT)/RISOTTO





Använd koppen för att hälla grynen (ris, havregryn, korn etc.) i skålen

Porridge (gröt)

Använd skalan till höger, inuti skålen, som är markerad från ½ till 1½.

Fyll inte över maximal markering (**max**).



Congee



- Använd skalan på mitten, inuti skålen, som är markerad från 1 till 3.
 - Fyll inte över maximal markering (**max**).
- Fyll skålen med vatten upp till det nummer som motsvarar antal koppar gryn.
 - Stäng locket.
 - Använd knappen  för att välja  i menyn.
 - Välj tillagningstiden. Standardtiden är 1 timme.
 - Du kan bara använda h- och min-knapparna när displaytiden blinkar.
 - Använd min-knappen för att bläddra mellan alternativen i displayen (5, 10, 15, 20, 25, 30, 35, 40, 45, 50 och 55).
 - Använd h-knappen för att bläddra mellan alternativen i displayen (1, 2, 3 och 4).
 - För att ta bort 4-timmeställningen, tryck på h-knappen igen medan displaytiden blinkar.
 - Om du inte gör någonting under 2 minuter kommer apparaten att återgå till standbyläge.
 - Man kan också använda timern med detta program (se TIMER).
 - Tryck på -knappen.
 - Displayen räknar ned.
 - Vid slutet av tillagningstiden kommer apparaten att sättas i "varmhållningsläge".
 - Signallampan  tänds.
 - Tryck på -knappen. Öppna locket. Ta ut maten.

Risotto



Följ receptet som visas senare i detta häfte.

TÅRTA







- Tina fryst deg ordentligt innan den används.
- Fyll inte skålen mer än till hälften.
- Gnid skålen med matlagingsolja.
- Placera degen i skålen.
- Stäng locket.
- Använd knappen  för att välja  i menyn.
- Välj tillagningstiden. Standardtiden är 40 minuter.



- Standardtiden är 40 minuter.
- Du kan bara använda h- och min-knapparna när displaytiden blinkar.
- Använd min-knappen för att bläddra mellan alternativen i displayen (5, 10, 15, 20, 25, 30, 35, 40, 45, 50 och 55).
- Använd h-knappen för att bläddra mellan alternativen i displayen (1 och 2).
- För att ta bort 2-timmeställningen, tryck på h-knappen igen medan displaytiden blinkar.
- Om du inte gör någonting under 2 minuter kommer apparaten att återgå till standbyläge.
- När du har ställt in tiden, tryck .
- Displayen räknar ned.
- Vid slutet av tillagningstiden kommer apparaten att sättas i "varmhållningsläge".
- Signallampan  tänds.
- Det är bäst att ta ut maten så fort den är klar, för att undvika att den blir svampig.
- Tryck på -knappen. Öppna locket. Ta ut maten.

VARMHÅLLNING

- Om du vill använda varmhållningsfunktionen efter ett program som inte stödjer den, när det enda som visas på displayen är ett blinkande -ljus, tryck .
- Tryck  för att avsluta denna funktion.

TIMERN

- Du kan använda fördröjningstimern med programmen för soppa , yoghurt , bröd , ångkokning  och porridge (gröt) .
- Gör detta omedelbart efter att du ställt in tillagningstiden och innan du trycker på start :

 - Tryck på -knappen. Signallampan  tänds.
 - Bestäm när du vill att maten ska vara klar.
 - Till exempel om klockan är 14:00 nu och du vill att den ska vara klar klockan 21:00 ska du ställa in tiden på 7 timmar.
 - Ställ in önskad tid med knapparna "h" och "min".
 - Tryck på -knappen.

SKÖTSEL OCH UNDERHÅLL

- Dra ur sladden till apparaten och låt apparaten svalna.
- Dra ut stickkontakten från vägguttaget och dra därefter ut kontakten på apparaten.
- Med locket stängt, ta tag i filtrets överdel och lyft det ur locket. FIG. A).
- Vänd på det för att visa markeringarna på framkanten.
- Håll filterlocket stadigt och vrid resten av filtret mot det öppna hänglåset  (FIG. B).
- Tryck på flikarna på botten av innerlocket och dra av det från apparaten (FIG. C).
- Diska avtagbara delar för hand.
- Torka av alla ytor med en ren och fuktig trasa.
- Lägg inte någon del av apparaten i en diskmaskin.
- Sätt ihop filtret igen och sätt tillbaka det i locket.
- Sätt tillbaka innerlocket i locket.

ÅTERVINNING











För att undvika miljö- och hälsoproblem pga. farliga ämnen får man inte kassera apparater eller laddningsbara och icke-laddningsbara batterier märkta med någon av dessa symboler i osorterat kommunalt avfall. Elektriska och elektroniska produkter och, där tillämpligt, laddningsbara och icke-laddningsbara batterier ska alltid kasseras vid en lämplig, officiell återvinnings-/uppsamlingsstation.



RECEPT

	matsked (15 ml)
	tesked (5 ml)
g	gram
ml	milliliter
	kopp
	stjälk (selleri)
	handfull
	ägg, medelstort (53-63 g)

	nypa
	bunt
	kvist
	klyfta/klyftor
	konservburk/burk
	burk
	smaktillsatser av olika slag (7 g)
	ägg, stort (63-73 g)

HEMLAGAD YOGHURT

YOGHURT





1200 ml mjölk

100 ml yoghurt

smakalternativ





50 g frysta blandade sommarbär

1  honung

Öppna locket. Tillsätt mjölken. Välj  i menyn och tryck sedan . Värm mjölken tills den börjar bubbla runt kanterna. Tryck  två gånger för att stoppa programmet. Låt mjölken svalna till mellan 37°C och 45°C. Vänd ned yoghurten i mjölken. Blanda noggrant för att undvika klumpar. Stäng locket. Välj  i menyn och tryck sedan . Vänta tills programmet är avslutat. Ställ in yoghurten i kylskåpet för att kyla den. Värm bären försiktigt i en kastrull. Tillsätt honungen. Ta bort bären från värmen när de börjar falla isär, låt svalna och blanda sedan med yoghurten. Om du vill förvara yoghurten måste du sterilisera de burkar du ska använda. Värm dem i en ugn vid 100 °C i 10 minuter. Yoghurten är hållbar i upp till 2 veckor i kylskåp.

CHILI MED GRÖNSAKER OCH COUSCOUS





LÅNGKOK

1	röd lök, hackad
1	stor lök, hackad
2 	vitlök, skalad och hackad
1	röd paprika, urkärnad och hackad
1	gul paprika, urkärnad och hackad
1	orange paprika, urkärnad och hackad
1 	mald koriander
1 	tomatpuré
850 ml	buljongtärning (vegetabilisk)
2 	stark tomatsås
120-140 ml	couscous

1 	olivolja
1 	limaböner
1 	cannellini-böner
1 	gröna jalapenos
1 	kidneyböner
1 	krossade tomat
2 	spiskummin
1 	socker
2 	chilipulver
2 	torkad oregano







servera:

riven ost
en liten bunt hackad koriander
gräddfil





Öppna locket. Tillsätt olja. Välj  i menyn och tryck sedan . Tillsätt lök och vitlök. Tillaga tills löken är mjuk. Låt börnorna rinna av och tillsätt dem. Ställ couscousen åt sidan. Tillsätt övriga ingredienser. Tryck  två gånger för att stoppa programmet. Stäng locket. Välj . Tillsätt couscousen när det återstår 30 minuter av tillagningstiden. Om tillagningen redan är klar, välj  i menyn och tillaga i ytterligare ca 20 minuter. Serveras i en skål med en handfull ost, en klick gräddfil och en aning färsk koriander. För klassisk vegetarisk chili kan man utesluta couscousen.

KRYDDSTARK NY-CHILI MED KÖTT

SJUDA









450 g	kött för bräsering
3 	vitlök, skalad och hackad
2 	spiskummin
1 	kajennepeppar
1 	rökt paprika-/chipotlepulver
1	grön paprika
1 	salt
1 	basilikablada, grovhackade



1 	olivolja
2	lökar, hackade
2 	chilipulver
2 	tomatsås
2 	tomater
1 	lagerblad
1 	svartpeppar
1 	kidneyböner

Öppna locket. Tillsätt olja. Välj  i menyn och tryck sedan . Hacka köttet, tomaterna och paprikan i munsbitsstora bitar. Bryn köttet, ställ det sedan åt sidan. Tillsätt löken, vitlöken och alla kryddor. Tillaga tills löken är mjuk. Tillsätt köttet. Ställ bönorna åt sidan. Tillsätt övriga ingredienser. Tryck  två gånger för att stoppa programmet. Stäng locket. Välj . Tillsätt bönorna när 30 minuter återstår av tillagningstiden. Om köttet fortfarande är lite segt när programmet har avslutats kan man tillsätta en kopp vatten och köra köttprogrammet i ytterligare 30 minuter.

MAROCKANSK FISKTAGINE

FISK 

2 	vitlök, skalad och hackad	1	lök, hackad
1	röd paprika, urkärnad och hackad	2 	stjälselleri, hackad
2	krossade tomater	1 	spiskummin
1 	mald ingefära	1 	gurkmeja
1	kanelstång	1 	harissapasta
120 ml	vitt vin	1 	tomatpuré
120 ml	fiskbuljong	1	citron
675 g	fisk (torsk/kolja/laxfilé)	1 	gröna oliver
1	en liten bunt hackad koriander		salt och peppar





Lägg koriandern åt sidan. Öppna locket. Tillsätt övriga ingredienser. Stäng locket. Välj  i menyn och tryck sedan . Tillaga tills fisken är skivig (40-60 minuter). Tryck  två gånger för att stoppa programmet. Tillsätt koriandern. Smaka av kryddningen före servering. Det här passar bra med couscous.



ÄRTSOPPA MED FLÄSKLÄGG

LÅNGKOK 



1150 ml	kycklingbuljong	1	lök, finhackad
225 g	delade ärtor	1	morot, hackad
1 	stjälselleri, hackad	2 	vitlök (krossad)
1 	timjan, finhackad	1 	lagerblad
1	fläsklägg		svartpeppar

Öppna locket. Häll på buljongen. Välj  i menyn och tryck sedan . Låt koka under omrörning. Sjud i 10 minuter. Tillsätt övriga ingredienser. Tryck  två gånger för att stoppa programmet. Stäng locket. Välj . Vänta tills programmet är avslutat. Lyft bort fläsklägget. Avlägsna skinnet och benen. Skär köttet i tärningar. Avlägsna lagerbladet. Mosa ärtorna med baksidan på en träslev. Tillsätt köttet. Smaka av kryddningen före servering. Himmelriket i en skål!

LAX MED STARK KRYDDBLANDNING

FISK 

2	laxfiléer (med skinn)	1 	olivolja
1 	paprika	1 	chilipulver
½ 	spiskummin	1 	salt och peppar
1 	mjukt farinsocker	1	citron

Blanda paprika, chilipulver, kummin, socker, salt och paprika. Strö över laxfiléerna. Öppna locket. Tillsätt olja. Välj  i menyn och tryck sedan . Vänta i några minuter medan oljan värms upp. Tillsätt filéerna med skinnet nedåt. Stäng locket. Detta är en jättebra kombination av ångtillagning och fritering av fiskbitar, som gör att man får en krispig yta på skinnet. Serveras med en citronklyfta. En underbar, lätt måltid.

IRLÄNSK GRYTA (STEW) MED GETOSTDUMPLINGS

SJUDA 





för grytan:

1.8 kg	lambbrog (tillagad)	1 	olivolja
250 g	bacon	3 	vitlök (krossad)
950 ml	lambbuljong		salt och peppar
1	stor lök, hackad	2	morötter, hackade
2 	stjälselleri, hackad	2 	rosmarin, hackad
2 	tomatpuré	1 	majsmjöl

till dumplings:

100 g	vetemjöl med bakpulver	1	☞	bakpulver
50 g	talg	1	☞	salt
75 ml	vatten	1	☞	torkad persilja
40 g	getost (mjuk)	1	☞	torkad timjan
1	torkad mejram	1	☞	svartpeppar

för grytan:

Avlägsna köttet från benet. Skär kött och bacon i munsbitsstora bitar. Öppna locket. Välj  i menyn och tryck sedan . Häll på buljongen. Låt koka under omrörning. Sjud i 10 minuter. Häll buljongen i en tillbringare. Tillsätt olja. Fräs löken i fett så att den blir mjuk. Tillsätt köttet, vitlök, kryddor och övriga grönsaker och tillaga i 5 minuter. Häll på buljongen. Tillsätt tomatpurén. Tryck  två gånger för att stoppa programmet. Stäng locket. Välj .

till dumplings:

Blanda alla ingredienser för hand. Fördela blandningen i 6 bollar. Låt degen vila 20 minuter.

för att avsluta:

Blanda majsmjölet och lite vatten till en slät smet i en kopp. Öppna locket 30 minuter innan tillagningen är klar. Rör i smeten i grytan. Tillsätt dumplings. Stäng locket. Vänta tills programmet är avslutat och servera sedan. En fantastisk, välgörande måltid i en skål!

- Om du inte har något tillagat lammkött kan du använda rått lammkött med programmet för långsam tillagning, istället för grytprogrammet och sedan fortsätta från dumplingssteget.



BROWNIKAKA

TÅRTA

170 g	osaltat smör	3	Ⓣ	
340 g	socker	1	☞	vaniljsocker
170 g	kakaopulver	1	☞	salt
110 g	mjölkchokladdroppar	75 g		vanligt vetemjöl

servera:



vaniljglass (kan uteslutas)

Smält smöret i en kastrull på låg värme. Klä skålen med smörat foliepapper. Vispa det smälta smöret, socker, kakao, mjöl, ägg, vaniljsocker och salt i en skål. Vänd ned chokladdropparna. Häll smeten i foliepappret inuti skålen. Stäng locket. Välj  i menyn. Ställ in tillagningstiden till 1 timme och 30 minuter. Tryck på -knappen. Kakan bör vara fast i kanterna och något kladdig i mitten. Servera kakan varm med glass som tillbehör.

ÅNGKOKT KRONÄRTSKOCKA

ÅNGKOKA

1 	vitlök, skalad och hackad	2		kronärtskockor
	örtkvistar (dragon, mynta, persilja, timjan)	1		citron

Skiva citronen. Skär av stjälken tätt intill änden av varje kronärtskocka. Skär av den övre fjärdedelen av varje kronärtskocka. Ta bort skadade blad. Gnid skärytorna med en citronskiva. Lägg citronskivorna i korgen. Tillsätt örtkvistarna. Tillsätt vitlöken. Placera kronärtskockan överst. Fyll på med vatten till nivå 2 på skalan till vänster inuti skålen. Placera korgen ovanpå skålen. Stäng locket. Välj  i menyn och tryck sedan . Kronärtskockorna är färdiglagade när de yttre bladen enkelt kan avlägsnas. Serveras varm eller kall med en vinäggret. Otroligt!





MÅLTIDSGRYTA MED PÄRLGRYN OCH BORLOTTIBÖNOR

SJUDA

1	☞	olivolja	1	☞	borlottibönor
175 g		pärlgryn	1		lök, finhackad
1	☞	krossade tomater	1	☞	tomatpuré
1000 ml		buljongtärning (vegetabilisk)	2	☞	persilja (hackad)
125 ml		torrt rödvin			salt och peppar

servera:

stark chiliolja (kan uteslutas)



Öppna locket. Välj  i menyn och tryck sedan . Häll på buljongen. Låt koka under omrörning. Sjud i 10 minuter. Häll buljongen i en tillbringare. Tillsätt olja. Fräs löken i fett så att den blir mjuk. Tillsätt vinet och tillaga i några minuter. Tillsätt pärlgrynen och rör om tills de tagit färg av vinet. Låt bönorna rinna av och tillsätt dem. Tillsätt tomaterna. Häll på buljongen. Tryck  två gånger för att stoppa programmet. Stäng locket. Välj . Öppna locket 30 minuter innan tillagningen är klar. Kontrollera vätskemängden i skålen. Tillsätt 150 ml hett vatten vid behov. Stäng locket. Vänta tills programmet är avslutat. Serveras med nybakat bröd och en skvätt stark chiliolja.

SOCKERKAKSPUDDING MED SIRAP

ÅNGKOKA 

115 g smör
100 g strösocker
175 g vetemjöl med bakpulver
4  ljus sirap



2 
 $\frac{1}{4}$  vaniljsocker
2  mjölk





Vispa äggen i en annan skål. Rör ihop smöret och sockret i en bunke. Tillsätt ett ägg i taget, sedan vaniljsocker och därefter mjöl. Rör ned mjölken. Smörj en ugnsfast form på 1200 ml. Häll sirapen i botten på den ugnsfasta formen och häll sedan på smeten. Täck med bakpapper och sedan foliepapper och knytn ihop med snöre. Öppna locket. Sätt in den ugnsfasta formen i apparaten. Tillsätt tillräckligt med kokande vatten i apparaten så att det når 3 cm under den övre kanten av den ugnsfasta formen. Stäng locket. Välj  i menyn. Ställ in tillagningstiden till 1 timme och 30 minuter. Tryck på -knappen. Vänta tills programmet är avslutat. Vänd puddingen upp och ned på ett fat och servera varm. Detta är en härlig efterrätt som passar året runt!

VITT FORMBRÖD

BRÖD 

1  ljus sirap
320 ml mjölk
500 g grovt vetemjöl

1  smör
1  torrstjävt
1  salt



Öppna locket. Tillsätt mjölken. Välj  i menyn och tryck sedan . Värm mjölken tills den börjar bubbla runt kanterna. Häll över mjölken i en tillbringare. Tryck  två gånger för att stoppa programmet. Låt mjölken svalna till mellan 37°C och 45°C. Smält smöret i en kastrull på låg värme. Blanda mjöl och salt i en bunke. Tillsätt jäst, smör och sirap. Tillsätt mjölken och knåda till en boll. Om degen är mycket kladdig kan man tillsätta lite mer mjöl. Täck och låt stå på en varm plats i 10 minuter. Knåda igen. Täck och låt stå på en varm plats i 10 minuter. Öppna locket. Välj  i menyn och tryck sedan . Stäng locket. Öppna locket 30 minuter innan tillagningen är klar. Vänd brödet upp och ned. Detta ger brödets överdel lite färg och en krispig skorpa. Vänta tills programmet är avslutat. Servera med massor av smör.

BIKARBONATBRÖD

BRÖD 

1  mix för bikarbonatbröd
350 ml vatten



smör

Öppna locket. Smörj skålen med smör. Välj  i menyn. Stäng locket. Ställ in tillagningstiden till 2 timmar och 15 minuter. Tryck på -knappen. Låt det värmas upp. Häll sodabrödsmixen i en bunke. Tillsätt vatten. Blanda för hand tills en boll formas. Öppna locket. Lägg degen i skålen. Dela upp degen i fyra delar med en degskrapa av plast. Stäng locket. Öppna locket 30 minuter innan tillagningen är klar. Vänd brödet upp och ned. Detta ger brödets överdel lite färg och en krispig skorpa. Vänta tills programmet är avslutat. Låt svalna på bakgaller. Servera med saltat smör som det är eller tillsammans med en måltid.

RÖDBETSRISOTTO I KÖKSASSISTENTEN

PORRIDGE (GRÖT)/RISOTTO 





400 g rödbetor
250 g arbori- eller risottoris
250 ml vitt vin
900 ml buljongtärning (vegetabilisk) / kycklingbuljong

2  olivolja
1 lök, finhackad
2  vitlök, skalad och hackad
1  timjan, finhackad



för att avsluta:

100 ml yoghurt
1  smör

1  persilja (hackad)



Öppna locket. Välj  i menyn och tryck sedan . Häll på buljongen. Låt koka under omrörning. Sjud i 10 minuter. Häll buljongen i en tillbringare. Tryck  två gånger för att stoppa programmet. Välj  i menyn och tryck sedan . Låt det värmas upp. Skala rödbetorna och skär i 1 cm stora tärningar. Lägg rödbetorna, vitlöken och löken i skålen. Tillaga tills löken är mjuk. Rör i riset. Stäng locket och tillaga i 3-4 minuter. Öppna locket. Rör i vinet. Stäng locket och tillaga i 3-4 minuter. Öppna locket. Tillsätt timjan. Häll på buljongen. Stäng locket. Vänta tills programmet är avslutat. Kontrollera riset – det bör ha tuggmotstånd men inte vara hårt. Om det inte är klart kan man tillsätta lite vatten och koka i några minuter till. Rör ned smöret – det ger risotton fin glans. Servera med en klick yoghurt och strö över persilja. Detta är en utsökt förrätt eller lätt lunch.

PORRIDGE (GRÖT)



2  havremjöl
1¼  salt

servera:

rörsocker



Öppna locket. Tillsätt havregryn, salt och socker. Fyll med vatten till 1½- nivån på skalan till höger inuti skålen. Stäng locket. Välj  i menyn och tryck sedan . Vänta tills programmet är avslutat. Serveras med mjölk eller grädde. Strö över farinsocker. Om man vill kan man också tillsätta torkade aprikoser eller katrinplommon (utan kärnor) när det återstår 15 minuter av tillagningstiden. Överbliven porridge kan förvaras i kylskåp i upp till 2 dagar och värmas upp på nytt.

PORRIDGE MED NÖTTER



½  havregryn
120 ml mjölk
1  malen kanel

servera:

ljus sirap



Öppna locket. Tillsätt havregryn, kanel, kokos och mjölk. Fyll med vatten till ½- nivån på skalan till höger inuti skålen. Stäng locket. Välj  i menyn och tryck sedan . Vänta tills programmet är avslutat. Ringla över ljus sirap och strö över hackad mandel.





smakfullt ris

 ris
2  ris
1 buljongtärning (grönsaksbuljong)
1 röd paprika, urkärnad och hackad
1  gurkmeja

Öppna locket. Lägg riset i skålen. Fyll på med vatten till nivå 2 på skalan till vänster inuti skålen. Smula buljongtärningen och rör ned den i vattnet. Tillsätt övriga ingredienser. Stäng locket. Välj . Vänta tills programmet är avslutat och servera sedan. Om riset inte är färdigt kan man låta det stå och ånga i några minuter med locket stängt.

TOMATSOPPA

1 lök, hackad
1  krossade tomater
1 röd paprika, urkärnad och hackad
550 ml kycklingbuljong
1  torkade örtekryddor

Öppna locket. Häll på buljongen. Välj  i menyn och tryck sedan . Låt koka under omrörning. Sjud i 10 minuter. Häll buljongen i en tillbringare. Tryck  två gånger för att stoppa programmet. Skala och tärna potatisen. Välj  i menyn och tryck sedan . Tillsätt olja. Tillsätt löken och paprikan. Tillaga tills löken är mjuk. Häll på buljongen. Tillsätt övriga ingredienser. Stäng locket. Vänta tills programmet är avslutat. Smaka av kryddningen. Servera med ett krispigt bröd.

PORRIDGE (GRÖT)/RISOTTO



vatten
2  socker

mjölk / kaffegrädde



PORRIDGE (GRÖT)/RISOTTO

vatten
3  torkad kokos

hackad mandel



vatten
2 morötter, hackade
2  stjälselleri, hackad
1  ärtor (kan uteslutas)



SOPPA





1  olivolja
2 krossade tomater
2 potatis
1  tomatpuré
1  svartpeppar

SOPPA MED CHORIZO, KÅL OCH ÄPPLE

SOPPA



- 1/4 chorizokorv, fint hackad
- 1 äpple
- 2  stjälkselleri, hackad
- 1/4 kål, finhackad
- 2  vitlök, skalad och hackad
- 1  salt
- 850 ml buljongtärning (vegetabilisk)





- 1 lök, finhackad
- 2 morötter, hackade
- 2 krossade tomater
- 1  tomatpuré
- 1  kajennpeppar
- 1  svartpeppar



Öppna locket. Välj  i menyn och tryck sedan . Fräs chorizon i två minuter. Tillsätt lök och vitlök. Tillaga tills löken är mjuk. Skala, kärna ur och hacka äpplet. Tillsätt övriga ingredienser. Tryck  två gånger för att stoppa programmet. Stäng locket. Välj  i menyn och tryck sedan . Vänta tills programmet är avslutat. Detta är en underbar soppa. Om du låter den stå i kylskåpet över natten utvecklas smaken ännu mer.

KYCKLING MED TOMATER OCH SVAMP

KÖTT

- 2 skinn- och benfria kycklingbröstfiléer
- 450 g brun svamp, hackad
- 2  vitlök, skalad och hackad
- 1  worcestersås
- salt och peppar



- 1  olivolja
- 1  krossade tomater
- 1  tomatsås
- 1  torkad oregano



Öppna locket. Välj  i menyn och tryck sedan . Tillsätt olja. Salta och peppra kycklingbrösten och lägg dem i skålen. Vänd på köttet så att det bryns på båda sidor. Tillsätt vitlök och svamp. Tillaga i 3-4 minuter. Vänd på kycklingen en gång. Tillsätt tomaterna, Worcestershiresås, tomatsås och oregano. Fortsätt tillaga, vänd kycklingen en gång till. Kontrollera att kycklingen är genomstekt. Servera med pasta, potatis eller ris. En snabb och god måltid med ingredienser ur skafferiet.

STOUTBRYNTA REVBENSPPJÄLL MED SIRAP OCH SOJASÅS

KÖTT



- 1 kg fläskrevben
- 350 ml Guinness/stout
- 140 ml köttbuljong/fläskbuljong
- 60 ml lönsrirap / honung

- 1 lök, hackad
- 1  olivolja
- 3  vitlök, skalad och hackad
- 2  mörk sojasås





Öppna locket. Välj  i menyn. Tillsätt olja. Ställ in tillagningstiden till 1 timme och 45 minuter. Tryck på -knappen. Tillsätt revbenen och bryn i 5 minuter. Vänd några gånger. Ta ut revbenen. Tillsätt lök och vitlök. Tillaga tills löken är mjuk. Lägg tillbaka revbenen i skålen. Rör ned Guinness, buljong, lönsrirap och sojasås. Stäng locket. Vänta tills programmet är avslutat. Smaka av kryddningen före servering. En härlig förrätt eller som del av en plocklunch

ALLT-I-ETT-MÅLTID MED BRINGA

LÅNGKOK

- 1 kg bringa
- 2  vitlök, skalad och hackad
- 50 g chorizokorv, skivad
- 2 rödlökar, hackade
- 600 ml köttbuljong
- 2  torkade örterkryddor
- 6-8 potatis (små)
- 2  worcestersås

- 2  tomatpuré
- 2  lagerblad
- 2 morötter
- 3  selleri
- 2  rosmarin, hackad
- 1  krossade tomater
- salt och peppar

Lämna kvar skalet på potatisen. Skär potatisen, morötterna och sellerin i bitar. Salta och peppra bringan. Öppna locket. Välj  i menyn och tryck sedan . Häll på buljongen. Låt koka under omrörning. Sjud i 10 minuter. Häll buljongen i en tillbringare. Fräs chorizon i två minuter. Tillsätt köttet. Bryn hela köttet. Tillsätt lök, vitlök, potatis, selleri och morötter. Om du har andra rotsaker som behöver användas kan du tillsätta dem också. Tillaga tills löken är mjuk. Häll på buljongen. Tillsätt övriga ingredienser. Tryck  två gånger för att stoppa programmet. Välj . Vänta tills programmet är avslutat och servera sedan. Om man tillagar rätten i 8 timmar kommer den inte att ta skada av det, men den kommer troligen att vara klar att äta efter 5 timmar.

Les instruksjonene, oppbevar dem på et trygt sted, og send de med apparatet hvis du gir det videre. Fjern all emballasje før bruk.

VIKTIG SIKKERHETSTILTAK

Følg sikkerhetsinstruksene, inkludert

Dette apparatet kan brukes av barn fra åtte år og personer med nedsatte fysiske, sansende eller mentale evner eller manglende erfaring eller kunnskap hvis slike personer har fått opplæring eller blir holdt under oppsyn og forstår farene som er tilknyttet bruken av apparatet. Barn skal ikke leke med apparatet. Rengjøring og vedlikehold skal ikke utføres av barn med mindre de er over åtte år og holdes under oppsyn. Hold apparatet og ledningen utilgjengelig for barn under åtte år.

Hvis kontakten eller kabelen er ødelagt, må de skiftes ut med en spesiell del som fås fra produsenten eller produsentens servicerepresentant.

 Dypp aldri apparatet i væsker, ikke bruk det på badetrom, nær vann eller utendørs.

 Feil bruk av apparatet kan føre til skader.

 Apparatets overflater vil bli varme. Restvarmen vil holde overflatene varme etter bruk.

- Ikke legg frossen mat eller fugl i apparatet – tin helt opp før bruk.
- Kok kjøtt, fjørfe, og lignende produkter (kjøttdeig, hamburgere, osv.) til saften renner av. Stek fisk til den er ugjennomsiktig.
- Ikke forsøk å koke noe i selve apparatet – bruk kun bollen som kan tas ut.
- Ikke fyll den opp over maks.
- Ikke dekk til apparatet eller ha noe på det.
- Ta ut stikkkontakten og ta deretter ut kontakten fra apparatet.
- Dra ut kontakten til apparatet når det ikke er i bruk.
- Ikke bruk tilleggsutstyr eller annet utstyr annet enn de vi leverer.
- Ikke bruk apparatet til andre formål enn det som beskrives i disse instruksene.
- Ikke bruk apparatet hvis det er skadet eller har mangler.

KUN FOR BRUK I HJEMMET

FIGURER



- | | |
|------------------|-------------|
| 1. Kontrollpanel | 5. Målekopp |
| 2. Lokk | 6. Kurv |
| 3. Deksellås | 7. Bolle |
| 4. Innerlokk | 8. Plugg |

FORBEREDELSE

1. Sett apparatet på en stabil, flat og varmeherdet overflate.
2. Ikke bruk apparatet i nærheten av eller under gardiner, hyller, skap eller noe annet som kan ta skade av dampen som siver ut.
3. Bruk ovnsvotter (eller en klut) og en plate eller tallerken som tåler varme som du kan sette bollen på etter koking.



4. Sett bollen i kokeren.
5. Vri bollen en kvart gang til hver side, slik at du sørger for at bunnen av bollen har god kontakt med elementet.

RIS



1. Bruk målekoppen til å legge ris i bollen.
2. Ikke bruk mer enn 10 kopper ris.
3. Bruk skalaen til venstre, inne i bollen, som er merket fra 2 til 10.
4. Fyll bollen med vann opp til det tallet som svarer til antallet kopper ris som skal brukes.
5. Lukk dekslet.
6. Trykk på . Knappen vil lyse.
7. De ytre delene av displayet vil blinke mens maten varmes opp.
8. Displayet vil da vise gjenværende tilberedningstid (13 minutter), og telle ned.
9. På slutten av tilberedningstiden vil apparatet gå inn i varmebevaringsmodus.
10. -lyset vil lyse.
11. Åpne dekslet.
12. Løft ut bollen og sett den på en plate eller tallerken som tåler varme.
13. Trykk på .
14. Bruk spatelen til å vende og røre i risen, slik at all dampen forsvinner.
15. Noen ganger vil det dannes en skorpe der risen er i kontakt med bollen.
16. Hvis du ikke ønsker skorpe, kan du fjerne den med spatelen etter at risen er servert.



LANGSOM TILBEREDNING





1. Brune kjøtt og grønnsaker (se "BRUNE/SAUTERE/MYKNE/KOKE").
2. Kok opp kokevæsken (se "BRUNE/SAUTERE/MYKNE/KOKE").
3. Legg de faste ingrediensene i bollen og tilsett deretter kokevæsken.
4. Lukk dekslet.
5. Trykk på . Knappen vil lyse.
6. Displayet vil vise åtte timer og telle ned.
7. På slutten av tilberedningstiden vil apparatet gå inn i varmebevaringsmodus. -lyset vil lyse.
8. Trykk på . Åpne dekslet. Ta maten ut.

STUING





1. Brune kjøtt og grønnsaker (se "BRUNE/SAUTERE/MYKNE/KOKE").
2. Kok opp kokevæsken (se "BRUNE/SAUTERE/MYKNE/KOKE").
3. Legg de faste ingrediensene i bollen og tilsett deretter kokevæsken.
4. Lukk dekslet.
5. Trykk på . Knappen vil lyse.
6. Displayet vil vise én time og telle ned.
7. På slutten av tilberedningstiden vil apparatet gå inn i varmebevaringsmodus. -lyset vil lyse.
8. Trykk på . Åpne dekslet. Ta maten ut.

KJØTT

1. Gni maten helt inn med matolje.
2. Gni eventuelle krydder over matens overflate.
3. Legg en spiseskje med matolje i bollen.
4. Legg maten i bollen.
5. Lukk dekslet.
6. Tid avhenger av størrelsen.
7. Ikke tilbered mer enn ca. 500 g mat på en gang.
8. Vi foreslår koketider på 10 minutter + 10 minutter per 100 g for storfekjøtt.

- Ikke tilbered svinekjøtt eller fjærfe i kortere tid enn 5, 10, 15, 20, 25, 30 minutter.
- Bruk  knappen for å velge  i menyen.
- Velg tilberedningstid. Standardtiden er 20 minutter.
- Du kan bare bruke knappene h og min mens tiden i displayet blinker.
- Bruk min-knappen til å ta displayet gjennom alternativene (10, 15, 20, 25, 5, 10, 15, 20, 25, 30, 35, 40, 45, 50 og 55).
- Hvis du vil tilberede i én time, trykker du på h-knappen.
- Hvis du vil angre innstillingen på 1 time, trykker du på h-knappen igjen mens tiden i displayet blinker.
 - Hvis du ikke gjør noe i løpet av 2 minutter, vil apparatet gå tilbake til standby-modus.
- Når du har stilt inn tiden, trykker du på .
- Displayet teller ned.
- På slutten av tilberedningstiden vil apparatet gå inn i varmebevaringsmodus. -lyset vil lyse.
- Trykk på . Åpne dekslet. Ta maten ut.

SUPPE

- Brune kjøtt og grønnsaker (se "BRUNE/SAUTERE/MYKNE/KOKE").
- Legg de faste ingrediensene i bollen og tilsett deretter kokevæskan.
- Lukk dekslet.
- Bruk  knappen for å velge  i menyen.
- Velg tilberedningstid. Standardtiden er 1 time.
- Du kan bare bruke knappene h og min mens tiden i displayet blinker.
- Bruk min-knappen til å ta displayet gjennom alternativene (10, 15, 20, 25, 5, 10, 15, 20, 25, 30, 35, 40, 45, 50 og 55).
- Bruk h-knappen til å ta displayet gjennom alternativene (1, 2, 3, 4 og 5).
- Hvis du vil angre innstillingen på 5 time, trykker du på h-knappen igjen mens tiden i displayet blinker.
 - Hvis du ikke gjør noe i løpet av 2 minutter, vil apparatet gå tilbake til standby-modus.
- Du har muligheten til å bruke tidsbryteren med dette programmet (se under TIDSBRYTER).
- Trykk på .
- Displayet teller ned.
- På slutten av tilberedningstiden vil apparatet gå inn i varmebevaringsmodus. -lyset vil lyse.
- Trykk på . Åpne dekslet. Ta maten ut.

YOGHURT

Yoghurtkultur

Du kan bruke 5, 10, 15, 20, 25, 30 ml (2 spiseskjeer) med:

- Yoghurt med levende bakteriekultur og uten smak – den må være fersk (se etter lang utløpsdato). Forskjellige merker vil gi forskjellige resultater.

Yoghurt du har laget tidligere.

- Bakteriene svekkes over tid, så du kan bare gjøre dette ti ganger før du bruker en ny kultur.

Frysetørret yoghurtkultur fra apotek eller helsekostbutikk.





- Hvis instruksjonene på kulturpakken avviker fra denne veiledningen, følger du instruksjonene på pakken.

Melk

- Du vil trenge en liter melk.
- Helmelk gir tykkere yoghurt enn lettmelk.
- For å gjøre den enda tykkere kan du tilsette opp til åtte spiseskjeer melkepulver til den flytende melken.
- Du kan også bruke rekonstituert, pulverisert melk eller hermetisert fordampert melk.





Slik lager du yoghurt

- Du må drepe bakteriene i melken slik at de ikke konkurrerer med bakteriene i yoghurtkulturen.

2. Mens du varmer melken, lar du yoghurtkulturen komme opp til romtemperatur.
3. Åpne dekslet.
4. Bruk programmet DAMPING (BRUNE/SAUTERE/MYKNE/KOKE) til å varme melken opp til rett før koking.
5. Varm opp melken til den begynner å boble ved kantene.
6. La melken avkjøles til mellom 37°C og 45°C.
7. Rør yoghurtkultur inn i melken.
8. De må blandes godt sammen, ellers blir yoghurten kumpete.
9. Lukk dekslet.
10. Bruk  knappen for å velge  i menyen.
11. Velg tilberedningstid. Standardtiden er 8 timer.
12. Du kan bare bruke knappene h og min mens tiden i displayet blinker.
13. Bruk min-knappen til å ta displayet gjennom alternativene (10, 15, 20, 25, 5, 10, 15, 20, 25, 30, 35, 40, 45, 50 og 55).
14. Bruk h-knappen til å ta displayet gjennom alternativene (6, 7, 8, 9 og 10).
15. Hvis du vil angre innstillingen på 10 time, trykker du på h-knappen igjen mens tiden i displayet blinker.
 - Hvis du ikke gjør noe i løpet av 2 minutter, vil apparatet gå tilbake til standby-modus.
16. Du har muligheten til å bruke tidsbryteren med dette programmet (se under TIDSBRYTER).
17. Trykk på .
18. Displayet teller ned.
19. På slutten av tilberedningstiden vil apparatet gå inn i standbymodus.
20. Det vil ikke holde yoghurten varm.
21. Trykk på . Åpne dekslet. Ta maten ut.







BRØD



1. Du må tine frossen deig grundig før bruk.
2. Ikke tilbered mer enn ca. 500 g mat på en gang.
3. Tørk bollen med matolje.
4. Legg deigen i bollen.
5. Lukk dekslet.
6. Bruk knappen  til å velge  i menyen.
7. Velg tilberedningstid. Standardtiden er 3 timer.
8. Du kan bare bruke knappene h og min mens tiden i displayet blinker.
9. Bruk min-knappen til å ta displayet gjennom alternativene (10, 15, 20, 25, 5, 10, 15, 20, 25, 30, 35, 40, 45, 50 og 55).
10. Bruk h-knappen til å ta displayet gjennom alternativene (1, 2, 3, 4, 5 og 6).
11. Hvis du vil angre innstillingen på 6 time, trykker du på h-knappen igjen mens tiden i displayet blinker.
 - Hvis du ikke gjør noe i løpet av 2 minutter, vil apparatet gå tilbake til standby-modus.
12. Du har muligheten til å bruke tidsbryteren med dette programmet (se under TIDSBRYTER).
13. Trykk på .
14. Displayet teller ned.
15. På slutten av tilberedningstiden vil apparatet gå inn i varmebevaringsmodus. -lyset vil lyse.
16. Trykk på . Åpne dekslet. Ta maten ut.

FISK



1. Gni maten helt inn med matolje.
2. Gni eventuelle krydder over matens overflate.
3. Legg en spiseskje med matolje i bollen.
4. Legg maten i bollen.
5. Lukk dekslet.
6. Tid avhenger av størrelsen.
7. Ikke tilbered mer enn ca. 500 g mat på en gang.
8. Vi foreslår koketider på 10 minutter per 100 g vekt.

9. Bruk  knappen for å velge  i menyen.
10. Velg tilberedningstid. Standardtiden er 20 minutter.
11. Du kan bare bruke knappene h og min mens tiden i displayet blinker.
12. Bruk min-knappen til å ta displayet gjennom alternativene (10, 15, 20, 25, 5, 10, 15, 20, 25, 30, 35, 40, 45, 50 og 55).
13. Hvis du vil tilberede i én time, trykker du på h-knappen.
14. Hvis du vil angre innstillingen på 1 time, trykker du på h-knappen igjen mens tiden i displayet blinker.
 - Hvis du ikke gjør noe i løpet av 2 minutter, vil apparatet gå tilbake til standby-modus.
15. Når du har stilt inn tiden, trykker du på .
16. Displayet teller ned.
17. På slutten av tilberedningstiden vil apparatet gå inn i varmebevaringsmodus. -lyset vil lyse.
18. Det er best å ta ut maten så snart den er tilberedt, slik at den ikke tørker ut.
19. Trykk på . Åpne dekslet. Ta maten ut.

DAMPING

1. Fyll bollen med kaldt vann opp til 6-merket.
2. Sett kurven oppå bollen og legg maten i kurven.
3. For jevn koking bør du skjære alle matbitene i omtrent like størrelser.
4. Erter eller annen mat som kan smuldres opp og falle i vannet, bør du pakke inn i aluminiumsfolie.
5. Vær forsiktig når du pakker ut – bruk ovnsvotter og bruk klyper eller skjær av plast.
6. Lukk dekslet.
7. Bruk  knappen for å velge  i menyen.
8. Velg tilberedningstid. Standardtiden er 30 minutter.
 - Disse skal tilberedes ferdig innen standardtiden:

Mat (fersk)	Mengde
Grønne bønner	200g
Rosnkål	200g
Gulrøtter (skårne)	200g
Poteter (kvarter)	400g
Brokkoli	200g
Kvart	Kvart
Maiskolber	2

9. Du kan bare bruke knappene h og min mens tiden i displayet blinker.
10. Bruk min-knappen til å ta displayet gjennom alternativene (5, 10, 15, 20, 25, 30, 35, 40, 45, 50 og 55).
11. Bruk h-knappen til å ta displayet gjennom alternativene (1 og 2).
12. Hvis du vil angre innstillingen på 2 time, trykker du på h-knappen igjen mens tiden i displayet blinker.
 - Hvis du ikke gjør noe i løpet av 2 minutter, vil apparatet gå tilbake til standby-modus.
13. Du har muligheten til å bruke tidsbryteren med dette programmet (se under TIDSBRYTER).
14. Trykk på .
15. Displayet teller ned.
16. På slutten av tilberedningstiden vil apparatet gå inn i varmebevaringsmodus. -lyset vil lyse.
17. Det er best å ta ut maten så snart den er tilberedt, slik at den ikke blir for våt.
18. Trykk på . Åpne dekslet. Ta maten ut.

BRUNE/SAUTERE/MYKNE/KOKE

- Du kan bruke programmet DAMPING  ved standardinnstillingen og med lokket åpent, som en høytemperaturpanne i 5, 10, 15, 20, 25, 30 minutter, før du tilbereder med et annet program.

- Bruk det med litt olje til å brune kjøtt og grønnsaker, til å sautere, til å mykne opp løk, selleri, purre osv.
- Bruk det med vann eller kraft til å forvarme kokevæsker.
- Når du bytter til hovedprogrammet, er apparatet varmet opp, og noen eller alle ingrediensene vil allerede være i bollen.
- Du trenger da ikke å vaske pannen du ville ha brukt under forberedelsene.





GRØT/RISOTTO

Bruk målekoppen til å legge kornet (ris, havre, bygg osv.) i bollen.

Grøt

- Bruk skalaen til høyre, inne i bollen, som er merket fra ½ til 1 ½.
- Ikke fyll den opp over maks.





Congee

- Bruk skalaen i midten, inne i bollen, som er merket fra 1 til 3.
 - Ikke fyll den opp over maks.
1. Fyll bollen med vann opp til det tallet som svarer til antallet kopper korn.
 2. Lukk dekslet.
 3. Bruk  knappen for å velge  i menyen.
 4. Velg tilberedningstid. Standardtiden er 1 time.
 5. Du kan bare bruke knappene h og min mens tiden i displayet blinker.
 6. Bruk min-knappen til å ta displayet gjennom alternativene (5, 10, 15, 20, 25, 30, 35, 40, 45, 50 og 55).
 7. Bruk h-knappen til å ta displayet gjennom alternativene (1, 2, 3 og 4).
 8. Hvis du vil angre innstillingen på 4 time, trykker du på h-knappen igjen mens tiden i displayet blinker.
 - Hvis du ikke gjør noe i løpet av 2 minutter, vil apparatet gå tilbake til standby-modus.
 9. Du har muligheten til å bruke tidsbryteren med dette programmet (se under TIDSBRYTER).
 10. Trykk på .
 11. Displayet teller ned.
 12. På slutten av tilberedningstiden vil apparatet gå inn i varmebevaringsmodus. -lyset vil lyse.
 13. Trykk på . Åpne dekslet. Ta maten ut.

Risotto

Følg oppskriften som er oppgitt senere i dette heftet.



KAKE

1. Du må tine frossen deig grundig før bruk.
2. Ikke fyll bollen mer enn omtrent halvfull.
3. Tørk bollen med matolje.
4. Legg deigen i bollen.
5. Lukk dekslet.
6. Bruk  knappen for å velge  i menyen.
7. Velg tilberedningstid. Standardtiden er 40 minutter.
8. Standardtiden er 40 minutter.
9. Du kan bare bruke knappene h og min mens tiden i displayet blinker.
10. Bruk min-knappen til å ta displayet gjennom alternativene (5, 10, 15, 20, 25, 30, 35, 40, 45, 50 og 55).
11. Bruk h-knappen til å ta displayet gjennom alternativene (1 og 2).
12. Hvis du vil angre innstillingen på 2 time, trykker du på h-knappen igjen mens tiden i displayet blinker.
- Hvis du ikke gjør noe i løpet av 2 minutter, vil apparatet gå tilbake til standby-modus.
13. Når du har stilt inn tiden, trykker du på .
14. Displayet teller ned.
15. På slutten av tilberedningstiden vil apparatet gå inn i varmebevaringsmodus. -lyset vil lyse.
16. Det er best å ta ut maten så snart den er tilberedt, slik at den ikke blir for våt.











17. Trykk på . Åpne dekslet. Ta maten ut.

VARMEBEVARING

- Hvis du ønsker å bruke varmebevaringsfunksjonen etter et program som ikke støtter denne, trykker du på  når det eneste som vises på skjermen, er det blinkende  lyset.
- Trykk på  for å avslutte denne funksjonen.

TIDSBRYTEREN

- Du kan bruke tidsbryteren med programmene suppe , yoghurt , brød , damp  og grøt .
 - Gjør dette umiddelbart etter du har stilt inn tilberedningstiden, og før du trykker på start .
1. Trykk på . -lyset vil lyse.
 2. Bestem når du vil at maten skal være ferdig.
 3. Eksempel: Hvis klokken nå er 2.00 og du vil at maten skal være klar 9.00, må du stille inn tiden til 7 timer.
 4. Bruk knappene "h" og "min" for å stille inn riktig time og minutter.
 5. Trykk på .

STELL OG VEDLIKEHOLD







1. Koble fra apparatet og la det kjøle seg.
2. Ta ut stikkkontakten, og ta deretter ut kontakten av apparatet.
3. Med lokket lukket griper du tak i toppen av filteret og vipper det ut av lokket (FIG. A).
4. Vri det over slik at merkene på kanten foran vises.
5. Hold filterlokket og vri resten av filteret mot den åpne hengelåsen  (FIG. B).
6. Trykk på tappene nederst på innerlokket, og trekk det av apparatet (FIG. C).
7. Vask avtakbare deler for hånd.
8. Tørk av alle overflater med en ren fuktig klut.
9. Ikke ha noen av apparatets deler i oppvaskmaskinen.
10. Sett sammen filteret, og sett det tilbake i lokket.
11. Sett innerlokket tilbake i lokket.









RESIRKULERING



For å unngå miljø- og helseproblemer på grunn av farlige stoffer, må apparater og oppladbare og ikke-oppladbare batterier markert med en av disse symbolene ikke kastes i usortert offentlig avfall. Kast alltid elektriske og elektroniske produkter og, hvis relevant, oppladbare og ikke-oppladbare batterier, på et egnet retursted for offentlig resirkulering/innsamling.

OPPSKRIFTER

	spiseskje (15 ml)
	teskje (5 ml)
g	gram
ml	milliliter
	målekopp
	stang (selleri)
	håndfull
	egg, medium (53-63 gram)

	klype
	bunt
	kvast
	fedd
	boks
	glass
	pakke (7 g)
	egg, store (63-73 gram)

CHILI MED GRØNNSAKER OG KUSKUS

- 1 rødløk, hakket
- 1 stor løk, hakket
- 2 🥄 hvitløk, skrelt og hakket
- 1 rød pepper, uten frø og hakket
- 1 gul paprika, uten frø og hakket
- 1 oransje paprika, uten frø og hakket
- 1 🥄 malt koriander
- 1 🥄 tomatpuré
- 850 ml grønnsakkraft
- 2 🥄 sterk tomatsaus
- 120-140 ml kuskus

servering:

revet ost
liten bunt koriander, hakket

Åpne dekslet. Tilsett oljen. Velg 🍴 på menyen, og trykk på ⏏. Tilsett løk og hvitløk. Kok til løken mykner. La bønnene renne av, og tilsett dem. Legg kuskusen til side. Tilsett de øvrige ingrediensene. Trykk på ⏏ to ganger for å stoppe programmet. Lukk dekslet. Velg 🍴. Tilsett kuskusen 30 minutter før tilberedningen er ferdig. Hvis tilberedningen allerede er ferdig, velger du 🍴 på menyen og lar det koke i ca. 20 minutter til. Serveres i en bolle med en håndfull ost, toppet med rømme og et dryss av frisk koriander. For en klassisk vegetarchili utelater du kuskusen.

HJEMMELAGET YOGHURT

1200 ml melk

smaksalternativ

50 g frosne blandede skogsbær

Åpne dekslet. Ha i melken. Velg 🍴 på menyen, og trykk på ⏏. Varm opp melken til den begynner å boble ved kantene. Trykk på ⏏ to ganger for å stoppe programmet. La melken avkjøles til mellom 37°C og 45°C. Rør yoghurten inn i melken. De må blandes godt sammen, ellers blir yoghurten kumpete. Lukk dekslet. Velg 🍴 på menyen, og trykk på ⏏. Vent til programmet stopper. Sett yoghurt i kjøleskapet for å avkjøle helt. Varm bærene forsiktig i en panne. Ha i honningen. Når bærene begynner å ødelegges, må du fjerne dem fra varmen og la de avkjøles før de så blandes med yoghurten. Hvis du vil oppbevare yoghurten, må du sterilisere glassene du skal bruke. Varm dem i en ovn ved 100 °C i 10 minutter. Yoghurten holder seg opptil 2 uker i kjøleskapet.

FLAMMENDE NY CHILIBIFF

- 450 g grytekjøtt av okse
- 3 🥄 hvitløk, skrelt og hakket
- 2 🥄 malt spisskarve
- 1 🥄 kajennepepper
- 1 🥄 røkt paprika / chipotlepulver
- 1 grønn paprika
- 1 🥄 salt
- 1 🥄 basilikumblader, grovhakket

Åpne dekslet. Tilsett oljen. Velg 🍴 på menyen, og trykk på ⏏. Hakk opp kjøttet, tomater og paprika i passe store biter. Brun kjøttet og ta det ut igjen. Tilsett løk, hvitløk og alle urter. Kok til løken mykner. Tilsett kjøttet. Legg bønnene til side. Tilsett de øvrige ingrediensene. Trykk på ⏏ to ganger for å stoppe programmet. Lukk dekslet. Velg 🍴. Tilsett bønnene 30 minutter før tilberedningen er ferdig. Hvis kjøttet fremdeles er litt hardt ved slutten av programmet, kan du tilsette en kopp vann og kjøre kjøttprogrammet i ytterligere 30 minutter

LANGSOM TILBEREDNING 🍴

- 1 🥄 olivenolje
- 1 🍷 voksbønner
- 1 🍷 cannellini-bønner
- 1 🍷 grønne jalapenos
- 1 🍷 snittebønner
- 1 🍷 hakkede tomater
- 2 🥄 malt spisskarve
- 1 🥄 sukker
- 2 🥄 chilipulver
- 2 🥄 tørket oregano

rømme

YOGHURT 🍴

100 ml yoghurt









1 🥄 honning



STUE 🍴

- 1 🥄 olivenolje
- 2 løk, hakket
- 2 🥄 chilipulver
- 2 🥄 tomatsaus
- 2 🍷 tomater
- 1 🍷 laurbærblad
- 1 🥄 sort pepper
- 1 🍷 snittebønner

MAROKKANSK FISKETAGINE

FISK 



2 	hvitløk, skrelt og hakket	1	løk, hakket
1	rød pepper, uten frø og hakket	2 	stangselleri, hakket
2	hakkede tomater	1 	malt spisskarve
1 	malt ingefær	1 	gurkemeie
1	kanelstang	1 	harissasaus
120 ml	hvitvin	1 	tomatpuré
120 ml	fiskekraft	1	sitron
675 g	fisk (torsk/hyse/laksefilet)	1 	grønne oliven
1	liten bunt koriander, hakket		salt og pepper

Legg korianderen til side. Åpne dekslet. Tilsett de øvrige ingrediensene. Lukk dekslet. Velg  på menyen, og trykk på . Kok til fisken blir flakete (40–60 minutter). Trykk på  to ganger for å stoppe programmet. Tilsett koriander. Tilpass med krydder, og server. Dette er flott med couscous.

KRYDRET LAKS





FISK 





2	laksefileter (med skinn)	1 	olivenolje
1 	paprika	1 	chilipulver
½ 	malt spisskarve	1 	salt og pepper
1 	mykt brunt sukker	1	sitron

Bland paprika, chilipulver, spisskummen, sukker, salt og pepper. Dryss alt over laksefiletene. Åpne dekslet. Tilsett oljen. Velg  på menyen, og trykk på . Vent et par minutter til oljen er varm. Ha i filetene med skinnen ned. Lukk dekslet. Dette er en flott kombinasjon av damp og biter av fisk, men skinnen blir sprøtt. Server med en sitronbåt. En flott, lett måltid.

SUPPE MED GULE ERTER OG SKINKEKNOKE

LANGSOM TILBEREDNING 

1150 ml	buljongterning av kylling	1	løk, finhakket
225 g	gule erter	1	gulrot, hakket
1 	stangselleri, hakket	2 	hvitløk (knust)
1 	timian, finhakket	1 	laurbærblad
1	skinkeknoke		sort pepper



Åpne dekslet. Ha i ingrediensene. Velg  på menyen, og trykk på . Kok opp under omrøring. La det småkoke i 10 minutter. Tilsett de øvrige ingrediensene. Trykk på  to ganger for å stoppe programmet. Lukk dekslet. Velg . Vent til programmet stopper. Fjern skinkeknoken. Kast skinn og bein. Skjær kjøttet i terninger. Kast laurbærbladene. Mos ertene med baksiden av en tresleiv. Tilsett kjøttet. Tilpass med krydder, og server. Himmel i bolle!

SJOKOLADE BROWNIE

KAKE 

170 g	usaltet smør	3	 70
340 g	sukker	1 	vaniljeessens
170 g	kakao	1 	salt
110 g	melkesjokoladedråper	75 g	hvetemel



servering: vaniljeis (valgfritt)





Smelt smøret i en gryte over lav varme. Dekk bollen med smurt folie. Visp smeltet smør, sukker, kakaopulver, mel, egg, vanilje og salt sammen i en skål. Vend inn sjokoladedråpene. Legg røren i folien i bollen. Lukk dekslet. Velg  på menyen. Sett steketiden til 1 time og 30 minutter. Trykk på . Kaken skal være fast rundt kantene og litt klissete i midten. Kaken serveres varm, toppet med iskem.

IRSK STING (STEW) MED INNBAKT GEITOST

STUE 





til stuingen:

1.8 kg	lammeskulder (kokt)
250 g	stripete bacon
950 ml	lammekraft
1	stor løk, hakket
2 	stangselleri, hakket
2 	tomatpuré





1 	olivenolje
3 	hvitløk (knust)
	salt og pepper
2	gulrøtter, hakket
2 	rosmarin, hakket
1 	maismel

til fyllet (dumplings):

100 g	selvhevende mel
50 g	nyrefett
75 ml	vann
40 g	geitost (myk)
1 	tørket merian

1 	bakepulver
1 	salt
1 	tørket persille
1 	tørket timian
1 	sort pepper

til stuingen:

Fjern kjøttet fra benet. Skjær kjøttet og baconet i passe store biter. Åpne dekslet. Velg  på menyen, og trykk på . Ha i ingrediensene. Kok opp under omrøring. La det småkoke i 10 minutter. Hell kraften over i en mugge. Tilsett oljen. Tilsett løk og sauter til de er myke. Tilsett kjøtt, hvitløk, urter og andre grønnsaker, og la alt koke i 5 minutter. Ha i ingrediensene. Tilsett tomatpuré. Trykk på  to ganger for å stoppe programmet. Lukk dekslet. Velg .

til fyllet (dumplings):

Bland alle ingrediensene for hånd. Fordel blandingen på 6 baller. La det stå i ro i 20 minutter.

til slutt:



Lag en jevn saus av maismel og litt vann i en kopp. Åpne lokket 30 minutter før tilberedningen er ferdig. Rør sausen inn i stuingen. Ha i fyllet. Lukk lokket. Vent til programmet stopper, og server. En deilig bolle med utsøkt mat!

- Hvis du ikke har kokt lam, kan du bruke rått lam i stedet med programmet for langsom tilberedning i stedet for stuingprogrammet. Følg deretter oppskriften fra fyllet og ut.

DAMPET ARTISJOKK

DAMP 

1 	hvitløk, skrelt og hakket	2	artisjokker
	urtekvaster (estragon, mynte, persille, timian)	1	sitron

Skjær opp sitronen. Skjær av stilken ved bunnen av hver artisjokk. Skjær av den øvre fjerdedelen på hver artisjokk. Kast eventuelle ødelagte blader. Gni snittflatene med en skive sitron. Legg sitronskivene i kurven. Tilsett urtekvaster. Tilsett hvitløk. Legg artisjokken på toppen. Fyll opp med vann til nivå 2 på skalaen til venstre inne i bollen. Sett kurven opp på bollen. Lukk dekslet. Velg  på menyen, og trykk på . Artiskjokkene er kokt når de ytterste bladene kan fjernes enkelt. Serveres varm eller kald med en vinaigrettesaus. Utrolig! Utrolig!

GRYTE MED PERLEGRYN OG BORLOTTIBØNNER





STUE 

1 	olivenolje	1 	borlottibønner
175 g	perlegryn	1	løk, finhakket
1 	hakke tomater	1 	tomatpuré
1000 ml	grønnsakkraft	2 	persille (hakket)
125 ml	tørr rødvin		salt og pepper

servering:

sterk chiliolje (valgfritt)





Åpne dekslet. Velg  på menyen, og trykk på . Ha i ingrediensene. Kok opp under omrøring. La det småkoke i 10 minutter. Hell kraften over i en mugge. Tilsett oljen. Tilsett løk og sauter til de er myke. Tilsett vin og la det koke i noen minutter. Tilsett perlegryn og rør til det begynner å ta vinens farge. La bønnene renne av, og tilsett dem. Ha i tomatene. Ha i ingrediensene. Trykk på  to ganger for å stoppe programmet. Lukk dekslet. Velg . Åpne lokket 30 minutter før tilberedningen er ferdig. Sjekk væskemengden i bollen. Tilsett 150 ml varmt vann om nødvendig. Lukk dekslet. Vent til programmet stopper. Serveres med ferskt brød og en skvett varm chiliolje.

SUKKERBRØDPUDDING MED SIRUP

DAMP 





115 g	smør	2	
100 g	finkornet sukker	$\frac{1}{4}$ 	vaniljeessens
175 g	selvhevende mel	2 	melk
4 	sirup		

Pisk eggene i en bolle. Rør smør og sukker sammen i en bolle. Gradvis tilsett eggene, deretter vanilje, deretter melet. Rør inn melken. Smør en 1200 ml ildfast bolle. Legg sirupen i bunnen av den ildfaste bolle og blandingen på toppen. Dekk med bakepapir og deretter med folie, og knyt toppen med hysing. Åpne dekslet. Sett den ildfaste bollen inn i bollen på apparatet. Tilsett nok kokevann i bollen på apparatet til at det når opp til 3 cm under toppen av den ildfaste bollen. Lukk dekslet. Velg  på menyen. Sett steketiden til 1 time og 30 minutter. Trykk på . Vent til programmet stopper. Hell alt over på en tallerken. Serveres varmt. En flott pudding til alle årstider!!

HVITT LOFF

BRØD 



1 	sirup	1 	smør
320 ml	melk	1 	tørrgjær
500 g	sterkt hvitt brødmel	1 	salt

Åpne dekslet. Ha i melken. Velg  på menyen, og trykk på . Varm opp melken til den begynner å boble ved kantene. Hell melken over i en mugge. Trykk på  to ganger for å stoppe programmet. La melken avkjøles til mellom 37°C og 45°C. Smelt smøret i en gryte over lav varme. Sikt melet og saltet i en bolle. Tilsett gjær, smør og sirup. Tilsett melken og elt alt sammen til en ball. Hvis blandingen er veldig klissete, kan du tilsette litt ekstra mel. Dekk til og la det stå på et lunt sted i 10 minutter. Elt igjen. Dekk til og la det stå på et lunt sted i 10 minutter. Åpne dekslet. Velg  på menyen, og trykk på . Lukk dekslet. Åpne lokket 30 minutter før tilberedningen er ferdig. Snu brødet over. Dette vil bidra til å gi toppen av brødet noe farge og skorpe. Vent til programmet stopper. Serveres med masse smør.

SODABRØD

BRØD 

1 	sodabrødblanding		smør
350 ml	vann		

Åpne dekslet. Smør bollen med smør. Velg  på menyen. Lukk dekslet. Sett steketiden til 2 timer og 15 minutter. Trykk på . La den varmes opp. Ha sodabrødblanding i en bolle. Tilsett vann. Bland sammen for hånd til en ball. Åpne dekslet. Legg deigen i bollen. Del deigen i kvarte deler med en slikkepott. Lukk dekslet. Åpne lokket 30 minutter før tilberedningen er ferdig. Snu brødet over. Dette vil bidra til å gi toppen av brødet noe farge og skorpe. Vent til programmet stopper. Avkjøl på en rist. Serveres med saltet smør separat eller med et måltid.



PORRIDGE (GRØT)

GRØT/RISOTTO 

2 	havre		vann
$\frac{1}{4}$ 	salt	2 	sukker

servering:

mørkebrunt sukker melk / fløte

Åpne dekslet. Tilsett havremel, salt og sukker. Fyll opp med vann til nivå $1\frac{1}{2}$ på skalaen til høyre inne i bollen. Lukk dekslet. Velg  på menyen, og trykk på . Vent til programmet stopper. Serveres med melk eller fløte. Dryss med mørk brunt sukker. Hvis du vil, kan du tilsette hakkede tørkede aprikoser eller halve svsker (uten stener) 15 minutter før tilberedningen er ferdig. Porridge som blir til overs, kan oppbevares i kjøleskapet i opptil to dager før den varmes opp på nytt.

NØTTEPORRIDGE

½ havregryn
120 ml melk
1 malt kanel

servering:

sirup

GRØT/RISOTTO

vann
3 kokosflak

hakke mandler

Åpne dekslet. Tilsett havre, kanel, kokos og melk. Fyll opp med vann til nivå ½ på skalaen til høyre inne i bollen. Lukk dekslet. Velg på menyen, og trykk på . Vent til programmet stopper. Dryss over med sirup og strø hakke mandler på toppen.

RØDBETER RISOTTO

400 g rødbeter
250 g arbori/risotto ris
250 ml hvitvin
900 ml grønsakskraft / buljongterning av kylling

til slutt:

100 ml yoghurt
1 smør

GRØT/RISOTTO

2 olivenolje
1 løk, finhakket
2 hvitløk, skrelt og hakket
1 timian, finhakket

1 persille (hakket)

Åpne dekslet. Velg på menyen, og trykk på . Ha i ingrediensene. Kok opp under omrøring. La det småkoke i 10 minutter. Hell kraften over i en mugge. Trykk på to ganger for å stoppe programmet. Velg på menyen, og trykk på . La den varmes opp. Skrell rødbetene, og skjær de i 1 cm terninger. Legg rødbeter, hvitløk og løk i bollen. Kok til løken mykner. Rør inn risen. Lukk lokket og la det koke i 3–4 minutter. Åpne dekslet. Rør inn vinen. Lukk lokket og la det koke i 3–4 minutter. Åpne dekslet. Ha i timian. Ha i ingrediensene. Lukk dekslet. Vent til programmet stopper. Sjekk risen – den skal ha en svak mostand, men ikke være hard. Hvis den ikke er helt ferdig, må du tilsett litt vann og la det koke i noen minutter til. Rør inn smør – dette gir risottoen glans. Server med en klatt yoghurt og persilledryss. Dette er en virkelig god forretter eller som en lett lunsj.

SMAKFULL RIS

2 ris
1 suppeterning (grønnsaker)
1 rød pepper, uten frø og hakket
1 gurkemeie

vann
2 gulrøtter, hakket
2 stangselleri, hakket
1 erter (valgfritt)

Åpne dekslet. Legg risen i bollen. Fyll opp med vann til nivå 2 på skalaen til venstre inne i bollen. Knus buljongterningen og rør den ut i vannet. Tilsett de øvrige ingrediensene. Lukk dekslet. Velg . Vent til programmet stopper, og server. Hvis risen ikke er helt ferdig, lar du den stå i et par minutter og dampe med lokket på.

STOR TOMATSUPPE

1 løk, hakket
1 hakke tomater
1 rød pepper, uten frø og hakket
550 ml buljongterning av kylling
1 tørkede blandede urter

1 olivenolje
2 hakke tomater
2 poteter
1 tomatpuré
1 sort pepper

Åpne dekslet. Ha i ingrediensene. Velg på menyen, og trykk på . Kok opp under omrøring. La det småkoke i 10 minutter. Hell kraften over i en mugge. Trykk på to ganger for å stoppe programmet. Skrell potetene og skjær dem i terninger. Velg på menyen, og trykk på . Tilsett oljen. Tilsett løk og paprika. Kok til løken mykner. Ha i ingrediensene. Tilsett de øvrige ingrediensene. Lukk dekslet. Vent til programmet stopper. Tilpass med krydder. Server med ferskt brød.



RIS











SUPPE

SUPPE MED CHORIZO, KÅL OG EPLE

SUPPE



- ¼ chorizo, finhakket
- 1 eple
- 2  stangselleri, hakket
- ¼ nykål, finhakket
- 2  hvitløk, skrelt og hakket
- 1  salt
- 850 ml grønnsakkraft





- 1 løk, finhakket
- 2 gulrøtter, hakket
- 2 hakkede tomater
- 1  tomatpuré
- 1  kajennepepper
- 1  sort pepper



Åpne dekslet. Velg  på menyen, og trykk på . Sautere chorizoen i 2 minutter. Tilsett løk og hvitløk. Kok til løken mykner. Skrell eplet, ta ut kjernen, og skjær det opp. Tilsett de øvrige ingrediensene. Trykk på  to ganger for å stoppe programmet. Lukk dekslet. Velg  på menyen, og trykk på . Vent til programmet stopper. Dette er en herlig suppe, og hvis du la den over natten i kjøleskapet, vil smaken utvikle seg videre.

KYLLING MED TOMATER OG SOPP

KJØTT

- 2 kyllingbryst, uten skinn og ben
- 450 g brune sopp, hakket
- 2  hvitløk, skrelt og hakket
- 1  Worcestershire-saus
- salt og pepper



- 1  olivenolje
- 1  hakkede tomater
- 1  tomat saus
- 1  tørket oregano



Åpne dekslet. Velg  på menyen, og trykk på . Tilsett oljen. Krydre kyllingbrystene med salt og pepper, og legg dem i bollen. Snu kjøttet for å dekke begge sider. Tilsett hvitløk og sopp. Kok i 3–4 minutter og snu kyllingen én gang. Tilsett tomater, worcestersaus, tomat saus og oregano. Fortsett tilberedningen og snu kyllingen igjen. Sjekk at kyllingen er gjennomstekt. Serveres med pasta, poteter eller ris. Et raskt og velsmakende måltid fra matskapet.

STOUT-KOKT RIBBE MED LØNNESIRUP OG SOYA

KJØTT



- 1 kg svineribbe
- 350 ml Guinness/stout
- 140 ml oksekraft/svinekraft
- 60 ml lønnesirup / honning

- 1 løk, hakket
- 1  olivenolje
- 3  hvitløk, skrelt og hakket
- 2  mørk soyasaus





Åpne dekslet. Velg  på menyen. Tilsett oljen. Sett steketiden til 1 time og 45 minutter. Trykk på . Tilsett ribben og brun i 5 minutter – vend av og til. Ta ut ribben. Tilsett løk og hvitløk. Kok til løken mykner. Legg ribben tilbake i bollen. Rør inn Guinness, kraft, lønnesirup og soyasaus Lukk dekslet. Vent til programmet stopper. Tilpass med krydder, og server. En flott forrett eller som en del av en blandet lunsj.

OKSEBRYSTGRYTE

LANGSOM TILBEREDNING

- 1 kg oksebryst
- 2  hvitløk, skrelt og hakket
- 50 g chorizo, skiver
- 2 rødløk, hakket
- 600 ml oksekraft
- 2  tørkede blandede urter
- 6-8 poteter (små)
- 2  Worcestershire-saus

- 2  tomatpuré
- 2  laurbærblad
- 2 gulrøtter
- 3 selleri
- 2  rosmarin, hakket
- 1  hakkede tomater
- salt og pepper

La skinnet være på potetene. Skjær poteter, gulrøtter og selleri i biter. Krydre brystet med salt og pepper. Åpne dekslet. Velg  på menyen, og trykk på . Ha i ingrediensene. Kok opp under omrøring. La det småkoke i 10 minutter. Hell kraften over i en mugge. Sautere chorizoen i 2 minutter. Tilsett kjøttet. Brun hele stykket. Tilsett løk, hvitløk, poteter, selleri og gulrøtter. Hvis du har andre rotgrønnsaker som du vil bruke opp, kan du ha i disse også. Kok til løken mykner. Ha i ingrediensene. Tilsett de øvrige ingrediensene. Trykk på  to ganger for å stoppe programmet. Velg . Vent til programmet stopper, og server. En tilberedningstid på 8 timer vil ikke skade, men gryten vil trolig være klar etter 5 timer.

Lue käyttöohjeet, säilytä ne ja anna ne laitteen mukana, mikäli luovutat sen toiselle henkilölle. Poista kaikki pakkausmateriaali ennen käyttöä.

TÄRKEITÄ VAROTOIMIA

Seuraa perusvarotoimia, muun muassa seuraavia ohjeita:

Laitetta saavat käyttää yli 8-vuotiaat lapset ja henkilöt, joiden fyysinen, aistienvarainen tai henkinen toimintakyky on heikentynyt, tai joilla ei ole kokemusta ja tietoa, jos heitä valvotaan/ohjeistetaan, ja he ymmärtävät käyttöön liittyvät vaarat. Lapset eivät saa leikkiä laitteella. Lapset eivät saa puhdistaa tai tehdä hoitotoimia, jos he eivät ole yli 8-vuotiaita ja valvonnan alla. Pidä laite ja kaapeli alle 8-vuotiaiden ulottumattomissa.

Jos liitin tai johto vaurioituu, se pitää vaihtaa erityisosaan, joka on saatavilla valmistajalta tai sen huoltoliikkeestä.

 Älä käytä tätä laitetta kylpyammeen, suihkun, pesualtaan tai muun vettä sisältävän säiliön lähellä.

 Laitteen väärinkäyttö saattaa aiheuttaa henkilövahingon.

 Laitteen pinnat tulevat kuumiksi. Jälkilämpö pitää pinnat kuumina käytön jälkeen.

- Älä laita jäässä olevaa lihaa tai siipikarjan lihaa laitteeseen – ne tulee sulattaa täysin ennen valmistamista.
- Valmista liha, kana ja lihatuotteet (jauheliha, hampurilaispihvit jne.) kunnes lihan neste on kirkasta. Valmista kala kunnes sen liha on läpikypsää.
- Älä valmista mitään keittimen runko-osassa – käytä valmistamiseen ainoastaan irrotettavaa kulhoa.
- Älä täytä yli maksimi tason.
- Älä peitä laitetta tai laita mitään sen päälle.
- Irrota pistoke pistorasiasta ja irrota vasta sitten virtaliitin laitteen liitännästä.
- Irrota laite verkkovirrasta silloin, kun se ei ole käytössä.
- Älä käytä muita valmistajan omia lisälaitteita.
- Älä käytä laitetta muihin kuin tässä käyttöohjeessa kuvattuihin tarkoituksiin.
- Älä käytä laitetta, jos se on vahingoittunut tai toimii huonosti.

VAIN KOTIKÄYTTÖÖN

PIIRROKSET



- | | |
|-------------------|---------------|
| 1. Ohjauspaneeli | 5. Mittakuppi |
| 2. Kansi | 6. Kori |
| 3. Kannen lukitus | 7. Kulho |
| 4. Sisäkansi | 8. Liitin |

VALMISTELU



1. Aseta laite vakaalla, tasaisella ja kuumuutta kestäväälle alustalle.
2. Älä käytä laitetta lähellä verhoja tai niiden alla tai hyllyjen, kaappien tai minkään muun nousevasta vesihöyrystä vahingoittuvan alla.
3. Käytä patakinnasta (tai liinaa) käsissä ja lämpöä kestäväää alustaa tai ruokalautasta, jonka päälle laitot kulhon valmistuksen jälkeen.
4. Laita kulho keittimen sisälle.

5. Käännä kulhoa neljänneskierroksen verran kumpaankin suuntaan, jotta varmistat kulhon pohjan kontaktin elementtiin.



RIISI

1. Käytä mittakuppia riisin mittaamisessa kulhoon.
2. Älä laita enempää kuin 10 kupillista riisiä.
3. Käytä kulhon sisällä olevaa vasemmanpuolista asteikkoa, joka on merkitty 2–10.
4. Täytä kulho vedellä vastaamaan käytettävien riisikupillisten määrää.
5. Sulje kansi.
6. Paina -painiketta. Nappiin syttyy valo.
7. Näytön uloisimmat segmentit vilkkuvat kun ruoka lämpiää.
8. Näytössä näkyy silloin jäljellä oleva valmistusaika (13 minuuttia), joka pienenee.
9. Valmistusajan lopussa laite siirtyy ”pidä lämpimänä”-tilaan.
10. Valo  palaa.
11. vaa kansi.
12. Nosta kulho pois ja aseta se lämmönkestävän alustan tai ruokalautasen päälle.
13. Paina -painiketta.
14. Käytä lastaa riisin kääntämiseen ja sekoittamiseen, jotta kaikki jäljellä oleva höyry haihtuu.
15. Joskus kulhoon kosketuksissa olevaan riisikerrokseen muodostuu kuorta.
16. Jos et halua sitä, voit poistaa sen lastalla sen jälkeen, kun olet tarjoillut riisin.

HIDAS VALMISTUS





1. Ruskista liha ja vihannekset (katso ”RUSKISTA/KUULLOTA/PEHMENNÄ/KEITÄ”).
2. Keitä valmistusneste (katso ”RUSKISTA/KUULLOTA/PEHMENNÄ/KEITÄ”).
3. Laita kiinteät ainesosat kulhoon, lisää sitten valmistusneste.
4. Sulje kansi.
5. Paina -painiketta. Nappiin syttyy valo.
6. Näytössä näkyy 8 tuntia, joka pienenee.
7. Valmistusajan lopussa laite siirtyy ”pidä lämpimänä”-tilaan. Valo  palaa.
8. Paina -painiketta. Avaa kansi. Poista ruoka.

HAUDUTUS





1. Ruskista liha ja vihannekset (katso ”RUSKISTA/KUULLOTA/PEHMENNÄ/KEITÄ”).
2. Keitä valmistusneste (katso ”RUSKISTA/KUULLOTA/PEHMENNÄ/KEITÄ”).
3. Laita kiinteät ainesosat kulhoon, lisää sitten valmistusneste.
4. Sulje kansi.
5. Paina -painiketta. Nappiin syttyy valo.
6. Näytössä näkyy 1 tunti, joka pienenee.
7. Valmistusajan lopussa laite siirtyy ”pidä lämpimänä”-tilaan. Valo  palaa.
8. Paina -painiketta. Avaa kansi. Poista ruoka.

LIHA

1. Hiero ruoan pintaan ruokaöljyä.
2. Hiero kaikki mausteet ruoan pintaan.
3. Laita ruokalusikallinen ruokaöljyä kulhoon.
4. Laita ruoka kulhoon.
5. Sulje kansi.
6. Aika riippuu ruokakappaleen koosta.
7. Älä valmista enempää kuin 500 g ruokaa kerralla.
8. Valmistusajaksi ehdotamme 10 minuuttia + 10 minuuttia jokaista 100 g lihan painoa kohden.
9. Älä valmista sianlihaa tai siipikarjanlihaa alle 5, 10, 15, 20, 25, 30 minuuttia.

10. Käyttämällä  -painiketta valitse  valikosta
11. Valitse valmistusaika. Oletusaika on 20 minuuttia.
12. Voit käyttää painikkeita h ja min, kun näytön aika vilkkuu.
13. Käytä painiketta min siirtyäksesi näytössä eri vaihtoehtoihin (10, 15, 20, 25, 5, 10, 15, 20, 25, 30, 35, 40, 45, 50 ja 55).
14. Jos haluat valmistusajaksi 1 tunnin, paina painiketta h.
15. Jos haluat peruuttaa 4 tunnin asetuksen, paina painiketta h uudelleen, kun näytön aika vilkkuu.
 - Jos et tee mitään 2 minuuttiin, laite palautuu valmiustilaan.
16. Kun olet asettanut ajan, paina 
17. Näytön aika alkaa pienetä.
18. Valmistusajan lopussa laite siirtyy "pidä lämpimänä"-tilaan. Valo  palaa.
19. Paina -painiketta. Avaa kansi. Poista ruoka.

KEITTO

1. Ruskista liha ja vihannekset (katso "RUSKISTA/KUULLOTA/PEHMENNÄ/KEITÄ").
2. Laita kiinteät ainesosat kulhoon, lisää sitten valmistusneste.
3. Sulje kansi.
4. Käyttämällä  -painiketta valitse  valikosta
5. Valitse valmistusaika. Oletusaika on 1 tunti.
6. Voit käyttää painikkeita h ja min, kun näytön aika vilkkuu.
7. Käytä painiketta min siirtyäksesi näytössä eri vaihtoehtoihin (10, 15, 20, 25, 5, 10, 15, 20, 25, 30, 35, 40, 45, 50 ja 55).
8. Käytä painiketta h siirtyäksesi näytössä eri vaihtoehtoihin (1, 2, 3, 4 ja 5).
9. Jos haluat peruuttaa 4 tunnin asetuksen, paina painiketta h uudelleen, kun näytön aika vilkkuu.
 - Jos et tee mitään 2 minuuttiin, laite palautuu valmiustilaan.
10. Voit käyttää tässä ohjelmassa ajastinta (katso AJASTIN).
11. Paina -painiketta.
12. Näytön aika alkaa pienetä.
13. Valmistusajan lopussa laite siirtyy "pidä lämpimänä"-tilaan. Valo  palaa.
14. Paina -painiketta. Avaa kansi. Poista ruoka.

JOGURTTI

Jogurtin siemen

Voit käyttää 5, 10, 15, 20, 25, 30 ml (2 ruokalusikallista):

- Maustamatonta jogurtia – täytyy olla tuoretta (viimeiseen myyntipäivään pitkä aika). Eri tuotemerkit antavat erilaisen lopputuloksen.

Aikaisemmin tekemääsi jogurtia.

- Bakteeri heikkenee ajan myötä, joten voit tehdä tämän vain 10 kertaa ennen kuin vaihdat uuden siemenen.

Pakastekuivattua jogurtin siementä apteekista tai luontaistuotekaupasta.





- Jos pakkauksen ohjeet eroavat tästä käyttöohjeesta, noudata pakkauksen ohjeita.

Maito





- Tarvitset 1 litran maitoa.
- Kulutusmaidosta saat paksumpaa jogurtia kuin kevytmaidosta.
- Voit tehdä vielä paksumpaa jogurtia lisäämällä nestemäisen maidon joukkoon enintään 8 ruokalusikallista maitojauhetta.
- Voit myös käyttää iskukuumennettua maitojauhetta tai makeuttamatonta maitotiivistettä.

Jogurtin valmistaminen



1. Sinun täytyy tappaa maidon bakteerit, jotta estät niiden kilpailun jogurtin siemenen bakteerien kanssa.
2. Samalla kun lämmität maitoa, anna jogurtin siemenen lämmetä huonelämpötilaan.
3. Avaa kansi.

4. Käytä ohjelmaa HÖYRYTYS (RUSKISTA/KUULLOTA/PEHMENNÄ/KEITÄ) maidon kuumentamiseen melkein kiehumiseen asti.
5. Anna maidon kuumentua, kunnes se alkaa kuplia reunoilta.
6. Anna maidon jäähtyä 37°C - 45°C lämpötilaan.
7. Sekoita jogurtin siemen maitoon.
8. Sekoita ne kunnolla, muuten jogurtista ei tule tasaista.
9. Sulje kansi.
10. Käyttämällä  -painiketta valitse  valikosta
11. Valitse valmistusaika. Oletusaika on 8 tuntia.
12. Voit käyttää painikkeita h ja min, kun näytön aika vilkkuu.
13. Käytä painiketta min siirtyäksesi näytössä eri vaihtoehtoihin (10, 15, 20, 25, 5, 10, 15, 20, 25, 30, 35, 40, 45, 50 ja 55).
14. Käytä painiketta h siirtyäksesi näytössä eri vaihtoehtoihin (6, 7, 8, 9 ja 10).
15. Jos haluat peruuttaa 4 tunnin asetuksen, paina painiketta h uudelleen, kun näytön aika vilkkuu.
 - Jos et tee mitään 2 minuuttiin, laite palautuu valmiustilaan.
16. Voit käyttää tässä ohjelmassa ajastinta (katso AJASTIN).
17. Paina -painiketta.
18. Näytön aika alkaa pienetä.
19. Valmistusajan lopussa laite siirtyy valmiustilaan.
20. Se ei pidä jogurttia lämpimänä.
21. Paina -painiketta. Avaa kansi. Poista ruoka.

LEIPÄ

1. Pakastettu taikina täytyy sulattaa täysin ennen käyttöä.
2. Älä valmista enempää kuin 500 g ruokaa kerralla.
3. Voitele kulho ruokaöljyllä.
4. Laita taikina kulhoon.
5. Sulje kansi.
6. Käyttämällä  -painiketta valitse  valikosta.
7. Valitse valmistusaika. Oletusaika on 3 tuntia.
8. Voit käyttää painikkeita h ja min, kun näytön aika vilkkuu.
9. Käytä painiketta min siirtyäksesi näytössä eri vaihtoehtoihin (10, 15, 20, 25, 5, 10, 15, 20, 25, 30, 35, 40, 45, 50 ja 55).
10. Käytä painiketta h siirtyäksesi näytössä eri vaihtoehtoihin (1, 2, 3, 4, 5 ja 6).
11. Jos haluat peruuttaa 4 tunnin asetuksen, paina painiketta h uudelleen, kun näytön aika vilkkuu.
 - Jos et tee mitään 2 minuuttiin, laite palautuu valmiustilaan.
12. Voit käyttää tässä ohjelmassa ajastinta (katso AJASTIN).
13. Paina -painiketta.
14. Näytön aika alkaa pienetä.
15. Valmistusajan lopussa laite siirtyy "pidä lämpimänä"-tilaan. Valo  palaa.
16. Paina -painiketta. Avaa kansi. Poista ruoka.

KALA

1. Hiero ruoan pintaan ruokaöljyä.
2. Hiero kaikki mausteet ruoan pintaan.
3. Laita ruokalusikallinen ruokaöljyä kulhoon.
4. Laita ruoka kulhoon.
5. Sulje kansi.
6. Aika riippuu ruokakappaleen koosta.
7. Älä valmista enempää kuin 500 g ruokaa kerralla.
8. Valmistusajoiksi ehdotamme 10 minuuttia 100 g painoa kohden.
9. Käyttämällä  -painiketta valitse  valikosta

10. Valitse valmistusaika. Oletusaika on 20 minuuttia.
11. Voit käyttää painikkeita h ja min, kun näytön aika vilkkuu.
12. Käytä painiketta min siirtyäksesi näytössä eri vaihtoehtoihin (10, 15, 20, 25, 5, 10, 15, 20, 25, 30, 35, 40, 45, 50 ja 55).
13. Jos haluat valmistusajaksi 1 tunnin, paina painiketta h.
14. Jos haluat peruuttaa 4 tunnin asetuksen, paina painiketta h uudelleen, kun näytön aika vilkkuu.
 - Jos et tee mitään 2 minuuttiin, laite palautuu valmiustilaan.
15. Kun olet asettanut ajan, paina ◊
16. Näytön aika alkaa pienetä.
17. Valmistusajan lopussa laite siirtyy "pidä lämpimänä"-tilaan. Valo ☼ palaa.
18. On parasta poistaa ruoka heti kun se on valmistunut, jotta vältetään sen kuivuminen.
19. Paina ◊-painiketta. Avaa kansi. Poista ruoka.

HÖYRYTYS

1. Täytä kulho kylmällä vedellä merkkiin 6 asti.
2. Aseta kori kulhon päälle ja laita ruoka koriin.
3. Leikkaa kaikki ruoka-aineet suunnilleen samankokoisiksi tasaisen kypsymisen varmistamiseksi.
4. Kääri kaikki ainekset, jotka voivat päästä veteen, kuten herneet, alumiinifolioon.
5. Ole varovainen poistaessasi paketin – käytä patakinnasta ja muovisia pihtejä/lusikoita.
6. Sulje kansi.
7. Käyttämällä ?-painiketta valitse ☼ valikosta
8. Valitse valmistusaika. Oletusaika on 30 minuuttia.
 - Seuraavien pitäisi valmistua oletusajassa:

Ruoka (tuore)	Määrä
Vihreät pavut	200g
ruusukaali	200g
porkkanat (viipaleina)	200g
perunoita (lohkottu neljään)	400g
parsakaali	200g
keräkaali	Neljännes
Maissintähkät	2

9. Voit käyttää painikkeita h ja min, kun näytön aika vilkkuu.
10. Käytä painiketta min siirtyäksesi näytössä eri vaihtoehtoihin (5, 10, 15, 20, 25, 30, 35, 40, 45, 50 ja 55).
11. Käytä painiketta h siirtyäksesi näytössä eri vaihtoehtoihin (1 ja 2).
12. Jos haluat peruuttaa 4 tunnin asetuksen, paina painiketta h uudelleen, kun näytön aika vilkkuu.
 - Jos et tee mitään 2 minuuttiin, laite palautuu valmiustilaan.
13. Voit käyttää tässä ohjelmassa ajastinta (katso AJASTIN).
14. Paina ◊-painiketta.
15. Näytön aika alkaa pienetä.
16. Valmistusajan lopussa laite siirtyy "pidä lämpimänä"-tilaan. Valo ☼ palaa.
17. On parasta poistaa ruoka heti kun se on valmistunut, jotta vältetään sen tuleminen vetiseksi.
18. Paina ◊-painiketta. Avaa kansi. Poista ruoka.

RUSKISTA/KUULLOTA/PEHMENNÄ/KEITÄ

- Voit käyttää ohjelmaa HÖYRYTYS ☼ sen oletusasetuksella ja kansi avoinna kuuman pannun tavoin ennen valmistusta toisella ohjelmalla.
- Käytä hieman öljyä lihan ja vihannesten ruskistamiseen sekä sipulien, sellerien, purjon ym. kuullottamiseen tai pehmentämiseen.



- Käytä vettä tai lientä valmistusnesteiden esikuumentamiseen.
- Kun kytket pääohjelmaan, laite on jo lämmennyt ja osa aineksista tai kaikki ainekset on jo kulhossa.
- Sinun ei tarvitse pestä pannua, kuten tavallisen valmistuksen jälkeen.





PUURO/RISOTTO

Käytä mittakuppia viljan (riisin, kauran, ohran jne.) lisäämisessä kulhoon.

Puuro

- Käytä kulhon sisällä olevaa oikeanpuolista asteikkoa, joka on merkitty ½–1½.
- Älä täytä yli maksimi tason.





Congee

- Käytä kulhon sisällä olevaa keskimmäistä asteikko, joka on merkitty 1–3.
 - Älä täytä yli maksimi tason.
1. Täytä kulho vedellä vastaamaan käytettävien viljakupillisten määrää.
 2. Sulje kansi.
 3. Käyttämällä  -painiketta valitse  valikosta
 4. Valitse valmistusaika. Oletusaika on 1 tunti.
 5. Voit käyttää painikkeita h ja min, kun näytön aika vilkkuu.
 6. Käytä painiketta min siirtyäksesi näytössä eri vaihtoehtoihin (5, 10, 15, 20, 25, 30, 35, 40, 45, 50 ja 55).
 7. Käytä painiketta h siirtyäksesi näytössä eri vaihtoehtoihin (1, 2, 3 ja 4).
 8. Jos haluat peruuttaa 4 tunnin asetuksen, paina painiketta h uudelleen, kun näytön aika vilkkuu.
 - Jos et tee mitään 2 minuuttiin, laite palautuu valmiustilaan.
 9. Voit käyttää tässä ohjelmassa ajastinta (katso AJASTIN).
 10. Paina  -painiketta.
 11. Näytön aika alkaa pienetä.
 12. Valmistusajan lopussa laite siirtyy "pidä lämpimänä"-tilaan. Valo  palaa.
 13. Paina  -painiketta. Avaa kansi. Poista ruoka.



Risotto

Noudata tässä vihkosessa jäljempänä olevaa reseptiä.









KAKKU

1. Pakastettu taikina täytyy sulattaa täysin ennen käyttöä.
2. Älä täytä kulhoa yli puolen välin.
3. Voitele kulho ruokaöljyllä.
4. Laita taikina kulhoon.
5. Sulje kansi.
6. Käyttämällä  -painiketta valitse  valikosta
7. Valitse valmistusaika. Oletusaika on 40 minuuttia.
8. Oletusaika on 40 minuuttia.
9. Voit käyttää painikkeita h ja min, kun näytön aika vilkkuu.
10. Käytä painiketta min siirtyäksesi näytössä eri vaihtoehtoihin (5, 10, 15, 20, 25, 30, 35, 40, 45, 50 ja 55).
11. Käytä painiketta h siirtyäksesi näytössä eri vaihtoehtoihin (1 ja 2).
12. Jos haluat peruuttaa 4 tunnin asetuksen, paina painiketta h uudelleen, kun näytön aika vilkkuu.
- Jos et tee mitään 2 minuuttiin, laite palautuu valmiustilaan.
13. Kun olet asettanut ajan, paina .
14. Näytön aika alkaa pienetä.
15. Valmistusajan lopussa laite siirtyy "pidä lämpimänä"-tilaan. Valo  palaa.
16. On parasta poistaa ruoka heti kun se on valmistunut, jotta vältetään sen tuleminen vetiseksi.
17. Paina  -painiketta. Avaa kansi. Poista ruoka.

PIDÄ LÄMPIMÄNÄ

- Jos haluat käyttää pidä lämpimänä ominaisuutta sellaisen ohjelman jälkeen, joka ei tue sitä, voit tehdä sen, kun näytössä näkyy ainoastaan vilkkuva , paina silloin .
- Painamalla  poistut tästä ominaisuudesta.

AJASTIN

- Voit käyttää viiveajastinta ohjelmissa keitto , jogurtti , leipä , höyry  ja puuro .
 - Tee tämä välittömästi, kun olet asettanut valmistusajan, ja ennen kuin painat käynnistys :
1. Paina -painiketta. Valo  palaa.
 2. Päättää milloin haluat ruoan olevan valmis.
 3. Esimerkiksi jos nyt on 14.00 ja haluat ruoan olevan valmis klo 21.00, ajaksi tulee asettaa 7 tuntia.
 4. Käytä valitsimia **h** ja **min** säätääksesi oikean tunnin ja minuutin.
 5. Paina -painiketta.

HOITO JA HUOLTO















1. Irrota laite verkkovirrasta ja anna sen jäähtyä.
2. Irrota ensin pistoke pistorasiasta ja irrota sitten virtaliitin laitteen liitännästä.
3. Kun kansi on kiinni, tartu suodattimen yläosaan ja käännä se pois kannesta. (KUVA A).
4. Käännä se ylösalaisin paljastaaksesi etureunan merkit.
5. Pidä suodattimen kansi kiinni ja käännä loput suodattimesta kohti avoimen lukon kuvaa  (KUVA B).
6. Paina sisäkannen alareunassa olevia ulokkeita, ja vedä se irti laitteesta (KUVA C).
7. Pese käsin irrotettavat osat.
8. Pyyhi kaikki pinnat puhtaalla, kostealla liinalla.
9. Älä laita laitteen mitään osaa astianpesukoneeseen.
10. Kokoa suodatin uudelleen ja laita takaisin kanteen.
11. Vaihda kannen sisäkansi.

KIERRÄTYS



Jotta vältettäisiin vaarallisista aineista ympäristölle ja terveydelle koituvat haitat, näillä symboleilla varustettuja laitteita sekä ladattavia ja kertakäyttöisiä paristoja ei saa hävittää lajittelemattomana sekajätteenä. Hävitä sähkö- ja elektroniikkatuotteet sekä, mikäli sovellettavissa, ladattavat ja kertakäyttöiset paristot asianmukaiseen viralliseen kierrätys-/keräilypisteeseen.

RESEPTIJÄ

	ruokalusikka (15ml)		hypypsellinen
	teelusikka (5ml)		nippu
g	grammaa		oksa
ml	millilitraa		kynsi(kynttä)
	mittakuppi		tölkki/säilykepurkki
	tanko/pala (selleriä)		purkki
	kourallinen		pussi (7 g)
	kananmuna, keskikokoinen (53-63 g)		kananmuna, iso (63-73 g)

KASVIS-KUSKUSCHILI

- 1 punasipuli pilkottuna
- 1 iso sipuli pilkottuna
- 2 valkosipulia, kuorittuna ja pilkottuna
- 1 vihreitä jalopenoja
- 1 jauhettua korianteria
- 1 tomaattipyyretä
- 850 ml vihanneslientä
- 2 tulista tomaattikastiketta
- 120-140 ml kuskusta
- 1 punainen paprika, siemenet poistettuina ja pilkottuna
- 1 keltainen paprika, siemenet poistettuina ja pilkottuna
- 1 keltainen paprika, siemenet poistettuina ja pilkottuna

tarjoilu:

- juustoraastetta
- pieni nippu korianteria, pilkottuna
- smetanaa

Avaa kansi. Lisää öljy. Valitse valikosta ja paina. Lisää sipuli ja valkosipuli. Keitä, kunnes sipulit ovat pehmeitä. Valuta pavut ja lisää ne seokseen. Pidä kuskus valmiina. Lisää loput ainekset. Lopeta ohjelma painamalla kaksi kertaa. Sulje kansi. Valitse. Lisää kuskus 30 minuuttia ennen ruoan valmistumista. Jos ruoka on jo valmiina, valitse valikosta ja lisää valmistusaikaa 20 minuuttia. Tarjoile kulhosta, ripottele päälle kourallinen juustoa, ripaus smetanaa sekä tuoretta korianteria. Jos haluat valmistaa perinteistä kasvischiliä, jätä kuskus pois.

KOTITEKOINEN JOGURTTI

- 1200 ml maitoa
- 100 ml jogurttia
- 50 g pakastettuja kesämarjoja
- 1 Hunajaa

Avaa kansi. Lisää maito. Valitse valikosta ja paina. Anna maidon kuumentua, kunnes se alkaa kuplita reunoilta. Lopeta ohjelma painamalla kaksi kertaa. Anna maidon jäähtyä 37°C - 45°C lämpötilaan. Sekoita jogurtti maitoon. Sekoita ne kunnolla, muuten jogurtista ei tule tasaista. Sulje kansi. Valitse valikosta ja paina. Odota kunnes ohjelma päättyy. Laita jogurtti jääkaappiin jäähtymään. Lämmitä marjoja hieman pannussa. Lisää hunaja. Kun marjat alkavat hajota, lopeta lämmittäminen, anna niiden jäähtyä ja sekoita sitten jogurttiin. Jos haluat säilyttää jogurtin, sinun täytyy steriloida purkit, joita aiot käyttää. Kuumenna niitä uunissa 100 °C:essa 10 minuuttia. Jogurtti säilyy jopa 2 viikkoa jääkaapissa.

TULINEN NY-NAUDANLIHACHILI

- 450 g haudutettavaa naudanlihaa
- 3 valkosipulia, kuorittuna ja pilkottuna
- 2 jauhettua kumina
- 1 cayenne-pippuri
- 1 savustettua paprika/chipotle-jauhetta
- 1 vihreä paprika
- 1 suolaa
- 1 basilikan lehtiä, karkeaksi pilkottuna

Avaa kansi. Lisää öljy. Valitse valikosta ja paina. Pilko liha, tomaatit ja paprika suupalan kokoisiksi lohkoiksi. Ruskista liha ja ota se sitten pois. Lisää sipulit, valkosipuli ja kaikki yrtit. Keitä, kunnes sipulit ovat pehmeitä. Lisää liha. Pidä pavut valmiina. Lisää loput ainekset. Lopeta ohjelma painamalla kaksi kertaa. Sulje kansi. Valitse. Lisää pavut 30 minuuttia ennen ruoan valmistumista. Jos liha on ohjelman loputtua vielä sitkeää, lisää kupillinen vettä ja käynnistä lihaohjelma vielä 30 minuutiksi.

HIDAS VALMISTUS

- 1 oliiviöljyä
- 1 voipapuja
- 1 cannellini-papuja
- 1 punaisia papuja
- 2 jauhettua kumina
- 1 sokeria
- 2 chili-jauhetta
- 2 kuivattua oreganoa
- 1 kuutioituja tomaatteja







JOGURTTI



HAUDUTUS



- 1 oliiviöljyä
- 2 sipulia pilkottuna
- 2 chili-jauhetta
- 2 tomaattikastiketta
- 2 tomaatteja
- 1 laakerinlehti
- 1 mustapippuria
- 1 punaisia papuja

MAROKKOLAINEN KALATAGINE



KALA



- 2  valkosipulia, kuorittuna ja pilkottuna
- 2  varsiselleri, pilkottuna
- 1  jauhettu kumina
- 1  kurkumaa
- 1  harissa-tahnaa
- 1  tomaattipyreetä
- 675 g kala (turskaa/koljaa/lohifilee)
- 1 pieni nippu korianteria, pilkottuna suolaa ja pippuria
- 1 punainen paprika, siemenet poistettuina ja pilkottuna





- 1 sipuli pilkottuna
- 2 kuutioituja tomaatteja
- 1  jauhettua inkivääriä
- 1 kanelitanko
- 120 ml valkoviiniä
- 120 ml kalalientä
- 1 sitruuna
- 1  vihreitä oliiveja

Pidä korianteri valmiina. Avaa kansi. Lisää loput ainekset. Sulje kansi. Valitse  valikosta ja paina . Keitä kalaa, kunnes se hajoaa (40–60 minuuttia). Lopeta ohjelma painamalla  kaksi kertaa. Lisää korianteri. Mausta ja tarjoile. Erittäin hyvää kuskusin kanssa.

KEITTO HALKAISTUISTA HERNEISTÄ JA SIANPOTKASTA HIDAS VALMISTUS

- 1150 ml kanalientä
- 225 g halkaistuja herneitä
- 1  varsiselleri, pilkottuna
- 1  timjamia hienoksi pilkottuna
- 1 sianpotka



- 1 sipuli hienoksi pilkottuna
- 1 porkkana pilkottuna
- 2  valkosipulia (murskattuna)
- 1  laakerinlehti mustapippuria



Avaa kansi. Lisää liemi. Valitse  valikosta ja paina . Kiehuta sekoittaen samalla. Hauduta 10-30 minuuttia. Lisää loput ainekset. Lopeta ohjelma painamalla  kaksi kertaa. Sulje kansi. Valitse . Odota kunnes ohjelma päättyy. Poista sianpotka. Heitä nahka ja luut pois. Kuutioi liha. Heitä laakerinlehti pois. Survo halkaistut herneet puukauhalla. Lisää liha. Mausta ja tarjoile.



Ihana kulhollinen!

MAUSTEILLA HIEROTTU LOHI

KALA

- 2 lohiflettä (nahallisia)
- 1  paprika
- 1  jauhettu kumina
- 1  fariinisokeria





- 1  oliiviöljyä
- 1  chili-jauhetta
- 1  suolaa ja pippuria
- 1 sitruuna

Sekoita paprika, chilijauhe, kumina, sokeri, suola ja pippuri. Ripottele lohifileiden päälle. Avaa kansi. Lisää öljy. Valitse  valikosta ja paina . Odota muutama minuutti, kunnes öljy on kuumentunut. Lisää fileet nahkapuoli alaspäin. Sulje kansi. Tämä on loistava kalanpalojen höyrytyksen ja paistamisen yhdistelmä ja samalla saat rapean nahan. Tarjoile sitruunalohkojen kanssa. Erinomainen kevyt ateria.

SUKLAABROWNIEKAKKU



KAKKU

- 170 g suolatonta voita
- 340 g sokeria
- 170 g kaakaojauhetta
- 110 g maitosuklaaraakeita

- 3    vaniljauutetta
- 1  Suolaa
- 75 g tavallisia jauhoja

tarjoilu:

vaniljajäätelöä (valinnainen)

Sulata voi pannussa pienellä lämmöllä. Vuoraa kulho voidellulla leivinpaperilla. Vatkaa sulatettu voi, sokeri, kaakaojauho, vehnäjauhot, munat, vanilja ja suola. Sekoita joukkoon suklaaraakeet. Kaada taikina paperiin kulhon sisälle. Sulje kansi. Valitse  valikosta. Aseta valmistusajaksi 1 tunti 30 minuuttia. Paina -painiketta. Kakun pitäisi olla kiinteä reunoilta ja hieman tahmea keskeltä. Tarjoile kakku lämpimänä jäätelön kanssa.

IRLANTILAINEN PATA VUOHENJUUSTONYTTIEN KANSSA

HAUDUTUS 🍲

pataan:

1.8 kg	lampaanlapaa (keitettynä)	1 🍷	oliiviöljyä
250 g	pekonia	3 🍃	valkosipulia (murskattuna)
950 ml	lampaanlientä		suolaa ja pippuria
1	iso sipuli pilkottuna	2	porkkanaa pilkottuna
2 🍌	varsiselleri, pilkottuna	2 🍃	rosmariinia silputtuna
2 🍷	tomaattipyreetä	1 🍷	maissijauhoa

nyytteihin:

100 g	itsestään nousevia jauhoja	1 🍷	leivinjauhetta
50 g	rasvaa	1 🍷	Suolaa
75 ml	vettä	1 🍷	kuivattua persiljaa
40 g	vuohenjuustoa (pehmeää)	1 🍷	kuivattua timjamia
1 🍷	kuivattua meiramia	1 🍷	mustapippuria

pataan:

Irrota liha luista. Paloittele liha ja pekoni suupalan kokoisiksi paloiksi. Avaa kansi. Valitse 🍷 valikosta ja paina ⬇️. Lisää liemi. Kiehuta sekoittaen samalla. Hauduta 10-30 minuuttia. Siirrä liemi astiaan. Lisää öljy. Lisää sipuli ja paista pehmeäksi. Lisää liha, valkosipuli, yrtit ja muut vihannekset, keitä 5 minuuttia. Lisää liemi. Lisää tomaattisose. Lopeta ohjelma painamalla 🍷 kaksi kertaa. Sulje kansi. Valitse 🍷.

nyytteihin:

Sekoita kaikki ainekset käsin. Jaa seos 6 palloksi. Anna levätä 20 minuuttia.

viimeistely:

Tee kuppiin pehmeä seos maissijauhosta ja tilkasta vettä. Avaa kansi 30 minuuttia ennen ruoan valmistumista. Sekoita tahna muhennokseen. Lisää nytyt. Sulje kansi. Odota kunnes ohjelma päättyy, tarjoile. Ihana kulhollinen lohturuokaa!

- Jos sinulla ei ole keitettyä lammasta, voit käyttää raakaa lampaanlihaa ja valmistaa sen hitaan valmistuksen ohjelmalla haudutusohjelman sijasta. Jatka sitten nytytien kohdasta eteenpäin.

HÖYRYTETYT ARTISOKAT

HÖYRY 🍲

1 🍃	valkosipulia, kuorittuna ja pilkottuna	2	latva-artisokkaa
	yrttien oksia (rakuuna, minttu, persilja, timjami)	1	sitruuna

Viipaloitu sitruuna. Leikkaa jokaisen artisokan varsi tasan kannan kanssa. Leikkaa jokaisen artisokan yläosasta neljäsos pois. Heitä vaurioituneet lehdet pois. Hiero leikattuja pintoja sitruunaviipaleella. Laita sitruunaviipaleet koriin. Lisää yrttien oksat. Lisää valkosipuli. Laita päälle artisokat. Täytä vettä kulhon sisäpuolella olevan vasemmanpuoleisen asteikon kohtaan 2 asti. Aseta kori kulhon päälle. Sulje kansi. Valitse 🍷 valikosta ja paina ⬇️. Artisokat ovat valmiita, kun uloimmat lehdet voidaan irrottaa helposti. Tarjoile lämpimänä tai kylmänä vinaigretten kanssa. Erinomaista!

PATA-ATERIA OHRARYNEISTÄ JA BORLOTTIPAVUISTA

HAUDUTUS 🍲

1 🍷	oliiviöljyä	1 🍲	borlottipapuja
175 g	ohraryynejä	1	sipuli hienoksi pilkottuna
1 🍲	kuutioituja tomaatteja	1 🍷	tomaattipyreetä
1000 ml	vihanneslientä	2 🍃	persilja (silputtuna)
125 ml	kuivaa punaviiniä		suolaa ja pippuria

tarjoilu:

tulista chiliöljyä (valinnainen)

Avaa kansi. Valitse 🍷 valikosta ja paina ⬇️. Lisää liemi. Kiehuta sekoittaen samalla. Hauduta 10-30 minuuttia. Siirrä liemi astiaan. Lisää öljy. Lisää sipuli ja paista pehmeäksi. Lisää viini ja keitä muutama minuutti. Lisää ohraryynit ja sekoita, kunnes ohra sekoittuu viiniin. Valuta pavut ja lisää ne seokseen. Lisää tomaatit. Lisää liemi. Lopeta ohjelma painamalla 🍷 kaksi kertaa. Sulje kansi. Valitse 🍷. Avaa kansi 30 minuuttia ennen ruoan valmistumista. Tarkista kulhossa olevan nesteen määrä. Lisää tarvittaessa 150 ml kuumaa vettä. Sulje kansi. Odota kunnes ohjelma päättyy. Tarjoile tuoreen rapean leivän ja tulisen chiliöljyn kanssa.

PEHMEÄ SIIRAPPIVANUKAS

115 g voita
100 g hienoa sokeria
175 g itsestään nousevia jauhoja
4 🍴 vaaleaa siirappia

2 60
¼ 🍴 vaniljauutetta
2 🍴 maitoa

HÖYRY 🍴

Vatkaa munat kulhossa. Vaahdota voi ja sokeri kulhossa. Lisää asteittain kanamunat sitten vanilja ja lopuksi jauhot. Sekoita joukkoon maito. Voitele 1200 ml:n uuninkestävä kulho. Laita siirappi uuninkestävän vuonan pohjalle ja seos sen päälle. Peitä leivinpaperilla, sitten foliolla ja sido päältä narulla. Avaa kansi. Aseta uuninkestävä kulho laitteen kulhon sisälle. Lisää kiehuvaa vettä laitteen kulhoon 3 cm alle uuninkestävän kulhon yläreunan. Sulje kansi. Valitse 🍴 valikosta. Aseta valmistusajaksi 1 tunti 30 minuuttia. Paina 🍴-painiketta. Odota kunnes ohjelma päättyy. Käännä ylösalaisin astiaan ja tarjoile lämpimänä. Tämä vanukas sopii erinomaisesti kaikkiin vuodenaikoihin!!

VALKOINEN LEIPÄ

1 🍴 vaaleaa siirappia
320 ml maitoa
500 g valkoisia leipäjauhoja

1 🍴 voita
1 🍴 kuivattua hiivaa
1 🍴 Suolaa

LEIPÄ 🍴

Avaa kansi. Lisää maito. Valitse 🍴 valikosta ja paina 🍴. Anna maidon kuumentua, kunnes se alkaa kuplia reunoilta. Siirrä maito astiaan. Lopeta ohjelma painamalla 🍴 kaksi kertaa. Anna maidon jäähtyä 37°C - 45°C lämpötilaan. Sulata voi pannussa pienellä lämmöllä. Sekoita vehnäjauho ja suola kulhossa. Lisää hiiva, voi ja siirappi. Lisää maito ja vaivaa taikina palloksi. Jos seos on hyvin tarttuvaa, lisää hieman jauhoja. Peitä ja jätä lämpimään paikkaan 10 minuutiksi. Vaivaa uudelleen. Peitä ja jätä lämpimään paikkaan 10 minuutiksi. Avaa kansi. Valitse 🍴 valikosta ja paina 🍴. Sulje kansi. Avaa kansi 30 minuuttia ennen ruoan valmistumista. Käännä leipä toisinpäin. Tämä antaa hieman väriä ja rapeutta leivän päällysosaa. Odota kunnes ohjelma päättyy. Tarjoile voin kanssa.

SOODALEIPÄ

1 🍴 leipäsoodaseosta
350 ml vettä

voita

LEIPÄ 🍴

Avaa kansi. Voitele kulho voilla. Valitse 🍴 valikosta. Sulje kansi. Aseta valmistusajaksi 2 tuntia 15 minuuttia. Paina 🍴-painiketta. Jätä lämpiämään. Laita leipäsoodaseos kulhoon. Lisää vesi. Sekoita käsin palloksi. Avaa kansi. Laita taikina kulhoon. Jaa taikina neljään osaan muovisella lastalla. Sulje kansi. Avaa kansi 30 minuuttia ennen ruoan valmistumista. Käännä leipä toisinpäin. Tämä antaa hieman väriä ja rapeutta leivän päällysosaa. Odota kunnes ohjelma päättyy. Anna jäähtyä ritilällä. Tarjoile yksinään suolatun voin kanssa tai aterian yhteydessä.

PUURO

2 🍴 kaurahiutaleita
¼ 🍴 Suolaa

vettä
2 🍴 sokeria

PUURO/RISOTTO 🍴

tarjoilu:

fariinisokeria

maitoa / hapankermaa

Avaa kansi. Lisää kauraryynit, suola ja sokeri. Täytä vettä kulhon sisällä olevan oikeanpuoleisen asteikon kohtaan 1½ asti. Sulje kansi. Valitse 🍴 valikosta ja paina 🍴. Odota kunnes ohjelma päättyy. Tarjoile maidon tai kerman kanssa. Sirottele päälle tummaa sokeria. Jos haluat voit lisätä pilkottuja kuivattuja aprikooseja tai luumunpuolikkaita (ilman kiviä) 15 minuuttia ennen valmistumista. Jäljelle jäänyt puuro säilyy jääkaapissa jopa 2 päivää ja voidaan lämmittää uudelleen.

PÄHKINÄINEN PUURO

½ ☐ kaurahiutaleita
120 ml maitoa
1 🍷 jauhettua kanelia

tarjoilu:

vaaleaa siirappia

PUURO/RISOTTO 🍴

vettä
3 🍷 kookoshiutaleita

mantelirouhetta

Avaa kansi. Lisää kaurahiutaleet, kaneli, kookos ja maito. Täytä vettä kulhon sisällä olevan oikeanpuoleisen asteikon kohtaan ½ asti. Sulje kansi. Valitse 🍴 valikosta ja paina ⏏. Odota kunnes ohjelma päättyy. Pirskota päälle vaaleaa siirappia ja ripottele pinnalle mantelirouhetta.

MONITOIMIKEITTIMEN PUNAJUURIRISOTTO

400 g punajuurta
250 g arborio-/risottoriisiä
1 🍷 timjamia hienoksi pilkottuna
2 🍴 valkosipulia, kuorittuna ja pilkottuna
900 ml vihanneslientä / kanalientä

viimeistely:

100 ml jogurttia
1 🍷 voita

PUURO/RISOTTO 🍴

2 🍷 oliiviöljyä
1 sipuli hienoksi pilkottuna
250 ml valkoviiniä

1 🍷 persiljaa (silputtuna)

Avaa kansi. Valitse 🍴 valikosta ja paina ⏏. Lisää liemi. Kiehuta sekoittaen samalla. Hauduta 10-30 minuuttia. Siirrä liemi astiaan. Lopeta ohjelma painamalla ⏏ kaksi kertaa. Valitse 🍴 valikosta ja paina ⏏. Jätä lämpiämään. Kuori punajuuret ja leikkaa 1 cm kuutioiksi. Laita punajuuret, valkosipuli ja sipuli kulhoon. Keitä, kunnes sipulit ovat pehmeitä. Sekoita joukkoon riisi. Sulje kansi ja keitä 3-4 minuuttia. Avaa kansi. Sekoita joukkoon viini. Sulje kansi ja keitä 3-4 minuuttia. Avaa kansi. Lisää timjami. Lisää liemi. Sulje kansi. Odota kunnes ohjelma päättyy. Tarkista riisi – sen pitäisi hieman karkeaa suussa, mutta ei kovaa. Jos se ei ole valmista, lisää hieman vettä ja keitä muutama minuutti lisää. Sekoita joukkoon voi. Tämä antaa risotolle kiiltoa. Lisää tarjoiltaessa loraus jogurttia ja sirottele persiljaa pinnalle. Tämä on hyvä alkupala tai kevyt lounas.

MAUSTETTU RIISI

2 ☐ riisiä
1 liemikuutio (kasvis)
2 🍷 varsiselleri, pilkottuna
1 🍷 herne valinnainen)
1 punainen paprika, siemenet poistettuina ja pilkottuna

Avaa kansi. Laita riisi kulhoon. Täytä vettä kulhon sisäpuolella olevan vasemmanpuoleisen asteikon kohtaan 2 asti. Murskaa lihaliemikuutio ja sekoita veteen. Lisää loput ainekset. Sulje kansi. Valitse 🍴. Odota kunnes ohjelma päättyy, tarjoile. Jos riisi ei ole valmista, jätä se vielä muutamaksi minuutiksi höyryntymään kansi suljettuna.

RIISI 🍴

vettä
2 porkkanaa pilkottuna
1 🍷 kurkumaa

RUNSAS TOMAATTIKEITTO

1 sipuli pilkottuna
1 ☐ kuutioituja tomaatteja
2 perunoita
1 🍷 tomaattipyreetä
1 🍷 mustapippuria
1 punainen paprika, siemenet poistettuina ja pilkottuna



Avaa kansi. Lisää liemi. Valitse 🍴 valikosta ja paina ⏏. Kiehuta sekoittaen samalla. Hauduta 10-30 minuuttia. Siirrä liemi astiaan. Lopeta ohjelma painamalla ⏏ kaksi kertaa. Kuori ja kuutioi perunat. Valitse 🍴 valikosta ja paina ⏏. Lisää öljy. Lisää sipuli ja paprika. Keitä, kunnes sipulit ovat pehmeitä. Lisää liemi. Lisää loput ainekset. Sulje kansi. Odota kunnes ohjelma päättyy. Mausta mieleiseksesi. Tarjoile rapean leivän kanssa.



KEITTO 🍴





1 🍷 oliiviöljyä
2 kuutioituja tomaatteja
550 ml kanalientä
1 🍷 kuivattuja yrttejä

CHORIZO-KAALI-OMENAKEITTO

KEITTO



- ¼ chorizo hienoksi pilkottuna
- 1 omena
- 2  varsiselleri, pilkottuna
- ¼ varhaiskaalia hienoksi pilkottuna
- 2  valkosipulia, kuorittuna ja pilkottuna
- 1  suolaa
- 850 ml vihanneslientä





- 1 sipuli hienoksi pilkottuna
- 2 porkkanaa pilkottuna
- 2 kuutioituja tomaatteja
- 1  tomaattipyreetä
- 1  cayenne-pippuri
- 1  mustapippuria



Avaa kansi. Valitse  valikosta ja paina . Ruskista chorizoa 2 minuuttia. Lisää sipuli ja valkosipuli. Keitä, kunnes sipulit ovat pehmeitä. Kuori omena, poista keskusta ja pilko. Lisää loput ainekset. Lopeta ohjelma painamalla  kaksi kertaa. Sulje kansi. Valitse  valikosta ja paina . Odota kunnes ohjelma päättyy. Tämä on maukas keitto, ja jos jätät sen jääkaappiin päiväksi, sen maku paranee entisestään.

KANAA, TOMAATTEJA JA SIENIÄ

LIHA

- 2 broilerinrintaa
- 450 g ruskista sienet pilkottuina
- 2  valkosipulia, kuorittuna ja pilkottuna
- 1  Worcestershire-kastiketta
- suolaa ja pippuria



- 1  oliiviöljyä
- 1  kuutioituja tomaatteja
- 1  tomaattikastiketta
- 1  kuivattua oreganoa



Avaa kansi. Valitse  valikosta ja paina . Lisää öljy. Mausta kanan rintapalat suolalla ja pippurilla ja laita ne kulhoon. Kääntele lihaa, jotta kumpikin puoli maustuu. Lisää valkosipuli ja sienet. Keitä 3–4 minuuttia, käännä kana kerran. Lisää tomaatit, Worcestershiren kastike, tomaattikastike ja oregano. Jatka keittämistä, käännä kana vielä kerran. Tarkista, että kana on riittävän kypsää. Tarjoile pastan, perunoiden tai riisin kanssa. Nopea ja maukas ateria aineksista mitä kaapista löytyy.

STOUTISSA HAUDUTETUT KYLKILUUT VAAHTERASIIRAPILLA JA SOIJALLA

LIHA



- 1 kg possun kylkiluita (ribsejä)
- 350 ml Guinnessia/stoutia
- 140 ml naudanlihalientä/sianlihalientä
- 3  valkosipulia, kuorittuna ja pilkottuna





- 1 sipuli pilkottuna
- 1  oliiviöljyä
- 2  tummaa soijakastiketta
- 60 ml vaahterasiirappia / hunajaa





Avaa kansi. Valitse  valikosta. Lisää öljy. Aseta valmistusajaksi 1 tunti 45 minuuttia. Paina -painiketta. Lisää kylkiluut ja ruskista 5 minuuttia – kääntele silloin tällöin. Poista kylkiluut. Lisää sipuli ja valkosipuli. Keitä, kunnes sipulit ovat pehmeitä. Laita kylkiluut takaisin kulhoon. Sekoita joukkoon Guinness, lihalieimi, vaahterasiirappi ja soijakastike. Sulje kansi. Odota kunnes ohjelma päättyy. Mausta ja tarjoile. Hyvä alkuruoka tai käsin syötävä lounas.

NAUDANRINTAPATA

HIDAS VALMISTUS

- 1 kg naudanrintaa
- 2  valkosipulia, kuorittuna ja pilkottuna
- 50 g chorizo-makkaraa viipaloituna
- 2 punasipulia silputtuna
- 600 ml naudanlihalientä
- 2  kuivattuja yrttejä
- 6-8 perunat (pienet)
- 2  Worcestershire-kastiketta

- 2  tomaattipyreetä
- 2  laakerinlehti
- 2 porkkanat
- 3  selleri
- 2  rosmariinia silputtuna
- 1  kuutioituja tomaatteja
- suolaa ja pippuria

Jätä perunoihin kuoret. Paloittele perunat, porkkanat ja selleri. Mausta naudanrinta suolalla ja pippurilla. Avaa kansi. Valitse  valikosta ja paina . Lisää liemi. Kiehuta sekoittaen samalla. Hauduta 10-30 minuuttia. Siirrä liemi astiaan. Ruskista chorizoa 2 minuuttia. Lisää liha. Ruskista joka puolelta. Lisää sipulit, valkosipuli, perunat, selleri ja porkkanat. Jos sinulla on muita juureksia, voit lisätä myös ne. Keitä, kunnes sipulit ovat pehmeitä. Lisää liemi. Lisää loput ainekset. Lopeta ohjelma painamalla  kaksi kertaa. Valitse . Odota kunnes ohjelma päättyy, tarjoile. Jopa 8 tunnin valmistusaika ei ole pahaksi, mutta ruoka on todennäköisesti valmis 5 tunnin kuluttua.

МУЛЬТИВАРКА

Прочтите инструкции, сохраните их, при передаче сопроводите инструкцией. Перед применением изделия снимите с него упаковку.

ВАЖНЫЕ МЕРЫ ПРЕДОСТОРОЖНОСТИ

Следуйте основным инструкциям по безопасности, включая следующие:

Использование данного устройства детьми старше 8 лет, лицами с ограниченными физическими, сенсорными или умственными способностями, недостатком опыта или знаний допускается при условии контроля или инструктажа и осознания связанных рисков. Детям запрещено играть с устройством. Очистку и обслуживание устройства могут выполнять дети старше 8 лет при условии наблюдения взрослыми. Храните устройство и кабель в недоступном для детей до 8 лет месте.

В случае повреждения соединительного разъема или провода произведите их замену, используя специальный комплект деталей, поставляемый производителем или его представителем по обслуживанию.

-  Не пользуйтесь устройством вблизи ванны, душа, бассейна или прочих емкостей с водой.
-  Неправильное использование прибора может привести к травме.
-  Поверхности прибора нагреваются. За счет остаточного тепла поверхности будут оставаться горячими после использования.
 - Не кладите в устройство замороженное мясо или птицу – перед использованием полностью размораживайте.
 - Готовьте мясо, птицу и продукты их переработки (фарш, рубленые бифштексы и т. д.) до тех пор, пока выделяемый сок не станет прозрачным. Готовьте рыбу до тех пор, пока мякоть не станет полностью матовой.
 - Не пытайтесь приготовить пищу в корпусе электрокастрюли – готовьте только в съемной чаше.
 - Не заполняйте чашу выше максимальной отметки (max).
 - Не накрывайте прибор и не размещайте ничего на его поверхности.
 - Отключите устройство от сети, а затем извлеките соединительный разъем из входного гнезда устройства.
 - Если прибор не используется, отключайте его от сетевой розетки.
 - Используйте только принадлежности и насадки от производителя.
 - Прибор не может работать от внешнего таймера или дистанционной системы управления.
 - Не используйте прибор, если он поврежден или работает с перебоями.

ТОЛЬКО ДЛЯ БЫТОВОГО ИСПОЛЬЗОВАНИЯ



ИЛЛЮСТРАЦИИ

- | | |
|----------------------|--------------------------|
| 1. Панель управления | 5. Мерная чашка |
| 2. Крышка | 6. Корзина |
| 3. Фиксатор крышки | 7. Чаша |
| 4. Внутренняя крышка | 8. Соединительный разъем |

ПРИГОТОВЛЕНИЕ



1. Устанавливайте прибор на устойчивую, горизонтальную, термостойкую поверхность.
2. Не помещайте устройство рядом или под занавесками, полками или стенными шкафчиками, а также поблизости от любых предметов, которые могут быть повреждены выбросом пара.
3. Извлекая чашу с приготовленным блюдом, используйте кухонные рукавицы (тряпку), и ставьте ее на термостойкую подставку или тарелку.
4. Поставьте чашу в электрокастрюлю.
5. Поверните чашу на четверть оборота поочередно в каждую сторону, чтобы ее дно вошло в плотный контакт с элементом.

РИС



1. Используйте мерную чашку, чтобы поместить рис в чашу.
2. Не используйте больше, чем 10 чашек риса.
3. Пользуйтесь левой шкалой с отметками от 2 до 10 на внутренней стороне чаши.
4. Наполните чашу водой до отметки, соответствующей количеству чашек используемого риса.
5. Закройте крышку.
6. Нажмите кнопку . Кнопка засветится.
7. Наружные сегменты дисплея будут мигать, пока пища нагревается.
8. Затем на дисплее отобразится оставшееся время приготовления (13 минут) и обратный отсчет.
9. В конце времени приготовления прибор перейдет в режим «поддержания температуры». Загорится индикатор .
10. Откройте крышку.
11. Извлеките чашу и поставьте ее на термостойкую подставку или тарелку.
12. Нажмите кнопку .
13. Перемешайте рис лопаткой, так чтобы вышел весь оставшийся пар.
14. Иногда слой риса, контактирующий с чашей, образует корку.
15. Если не хотите, вы можете удалить ее с помощью лопатки после подачи риса.







МЕДЛЕННОЕ ПРИГОТОВЛЕНИЕ

1. Обжаривание мяса и овощей (см. «ОБЖАРИВАНИЕ/ПАССЕРОВАНИЕ/ТУШЕНИЕ/ВАРКА»).
2. Закипятите жидкость, необходимую для приготовления блюда (см. «ОБЖАРИВАНИЕ/ПАССЕРОВАНИЕ/ТУШЕНИЕ/ВАРКА»).
3. Положите твердые ингредиенты в чашу, затем добавьте жидкость для приготовления.
4. Закройте крышку.
5. Нажмите кнопку . Кнопка засветится.
6. На дисплее отобразится 8 часов и обратный отсчет.
7. В конце времени приготовления прибор перейдет в режим «поддержания температуры». Загорится индикатор .
8. Нажмите кнопку . Откройте крышку. Извлеките пищевые продукты.





ТУШЕНИЕ

1. Обжаривание мяса и овощей (см. «ОБЖАРИВАНИЕ/ПАССЕРОВАНИЕ/ТУШЕНИЕ/ВАРКА»).
2. Закипятите жидкость, необходимую для приготовления блюда (см. «ОБЖАРИВАНИЕ/ПАССЕРОВАНИЕ/ТУШЕНИЕ/ВАРКА»).
3. Положите твердые ингредиенты в чашу, затем добавьте жидкость для приготовления.
4. Закройте крышку.
5. Нажмите кнопку . Кнопка засветится.
6. На дисплее отобразится 1 час и обратный отсчет.
7. В конце времени приготовления прибор перейдет в режим «поддержания температуры». Загорится индикатор .
8. Нажмите кнопку . Откройте крышку. Извлеките пищевые продукты.

МЯСО

1. Натрите мясо со всех сторон растительным маслом.
2. Посыпьте со всех сторон приправами.
3. Положите столовую ложку растительного масла в чашу.
4. Поместите мясо в чашу.
5. Закройте крышку.
6. Время зависит от размера порции.
7. Не готовьте больше, чем 500 г мяса за один прием.
8. Для говядины мы рекомендуем устанавливать время приготовления из расчета 10 минут + 10 минут на каждые 100 г мяса.
9. Свинину или птицу готовьте не менее 5, 10, 15, 20, 25, 30 минут.
10. С помощью кнопки  установите программу  в меню.
11. Выберите время приготовления. По умолчанию время приготовления составляет 20 минут.
12. Пока время на дисплее мигает, вы можете использовать только кнопки **h** и **min**.
13. Используйте кнопку **min**, чтобы изменить время приготовления на дисплее (возможные варианты: 10, 15, 20, 25, 5, 10, 15, 20, 25, 30, 35, 40, 45, 50 и 55).
14. Если вы хотите готовить более 1 часа, нажмите кнопку **h**.
15. Чтобы отменить установку 1 час, снова нажмите кнопку **h**, пока время на дисплее мигает.
- Если в течение 2 минут вы ничего не делаете, прибор перейдет в дежурный режим.
16. Когда вы установите время, нажмите .
17. На дисплее будет отображаться обратный отсчет времени.
18. В конце времени приготовления прибор перейдет в режим «поддержания температуры». Загорится индикатор .
19. Нажмите кнопку . Откройте крышку. Извлеките пищевые продукты.

СУП

1. Обжаривание мяса и овощей (см. «ОБЖАРИВАНИЕ/ПАССЕРОВАНИЕ/ТУШЕНИЕ/ВАРКА»).
2. Положите твердые ингредиенты в чашу, затем добавьте жидкость для приготовления.
3. Закройте крышку.
4. С помощью кнопки  установите программу  в меню.
5. Выберите время приготовления. По умолчанию время приготовления составляет 1 час.
6. Пока время на дисплее мигает, вы можете использовать только кнопки **h** и **min**.
7. Используйте кнопку **min**, чтобы изменить время приготовления на дисплее (возможные варианты: 10, 15, 20, 25, 5, 10, 15, 20, 25, 30, 35, 40, 45, 50 и 55).
8. Используйте кнопку **h**, чтобы изменить время приготовления на дисплее (возможные варианты: 1, 2, 3, 4 и 5).
9. Чтобы отменить установку 1 час, снова нажмите кнопку **h**, пока время на дисплее мигает.
- Если в течение 2 минут вы ничего не делаете, прибор перейдет в дежурный режим.
10. У вас есть возможность использования таймера для этой программы (см. ТАЙМЕР).
11. Нажмите кнопку .
12. На дисплее будет отображаться обратный отсчет времени.
13. В конце времени приготовления прибор перейдет в режим «поддержания температуры». Загорится индикатор .
14. Нажмите кнопку . Откройте крышку. Извлеките пищевые продукты.

ЙОГУРТ

Йогуртная закваска

Вы можете использовать 5, 10, 15, 20, 25, 30 мл (2 столовых ложки):

- неароматизированного «живого» йогурта — он должен быть свежим (ищите йогурт с большим сроком годности). Разные торговые марки дадут разные результаты.

йогурта, приготовленного вами ранее;

- Со временем жизненные силы бактерий ослабевают, поэтому вы можете делать это только 10 раз до использования другой новой закваски.





йогуртной закваски сублимационной сушки, приобретенной в аптеке или в магазине по продаже диетических продуктов.

- В случае если инструкция на упаковке с закваской отличается от этого руководства, следуйте инструкции на упаковке.

Молоко



- Вам понадобится 1 литр молока.
- Из цельного молока получается более густой йогурт, чем из обезжиренного молока.
- Для того чтобы сделать его более густым, вы можете добавить в питьевое молоко до 8 столовых ложек сухого молока.
- Вы также можете использовать восстановленное сухое молоко или консервированное сгущенное молоко.



приготовление йогурта

1. Вам необходимо убить бактерии в молоке для того, чтобы они не соперничали с бактериями в йогуртной закваске.
2. Пока вы нагреваете молоко, дайте йогуртной закваске нагреться до комнатной температуры.
3. Откройте крышку.
4. Используйте программу ПРОПАРИВАНИЕ (ОБЖАРИВАНИЕ/ПАССЕРОВАНИЕ/ТУШЕНИЕ/ВАРКА), чтобы подогреть молоко, немного не доводя до кипения.
5. Нагревайте молоко, пока по краям не начнут идти пузырьки.
6. Охладите молоко до температуры 37—45° С.
7. Размешайте йогуртную закваску в молоке.
8. Они должны быть тщательно перемешаны, в противном случае йогурт получится комковатым.
9. Закройте крышку.
10. С помощью кнопки  установите программу  в меню.
11. Выберите время приготовления. По умолчанию время приготовления составляет 8 часов.
12. Пока время на дисплее мигает, вы можете использовать только кнопки h и min.
13. Используйте кнопку min, чтобы изменить время приготовления на дисплее (возможные варианты: 10, 15, 20, 25, 5, 10, 15, 20, 25, 30, 35, 40, 45, 50 и 55).
14. Используйте кнопку h, чтобы изменить время приготовления на дисплее (возможные варианты: 6, 7, 8, 9 и 10).
15. Чтобы отменить установку 1 час, снова нажмите кнопку h, пока время на дисплее мигает.
- Если в течение 2 минут вы ничего не делаете, прибор перейдет в дежурный режим.
16. У вас есть возможность использования таймера для этой программы (см. ТАЙМЕР).
17. Нажмите кнопку .
18. На дисплее будет отображаться обратный отсчет времени.
19. В конце времени приготовления прибор перейдет в дежурный режим.
20. При этом теплая температура йогурта поддерживаться не будет.
21. Нажмите кнопку . Откройте крышку. Извлеките пищевые продукты.







ХЛЕБ



1. Разморозьте замороженное тесто перед использованием.
2. Не готовьте больше, чем 500 г мяса за один прием.
3. Смажьте чашу растительным маслом.
4. Поместите тесто в чашу.
5. Закройте крышку.
6. С помощью кнопки  установите программу  в меню.
7. Выберите время приготовления. По умолчанию время приготовления составляет 3 часов.
8. Пока время на дисплее мигает, вы можете использовать только кнопки h и min.
9. Используйте кнопку min, чтобы изменить время приготовления на дисплее (возможные варианты: 10, 15, 20, 25, 5, 10, 15, 20, 25, 30, 35, 40, 45, 50 и 55).

10. Используйте кнопку **h**, чтобы изменить время приготовления на дисплее (возможные варианты: 1, 2, 3, 4, 5 и 6).
11. Чтобы отменить установку 1 час, снова нажмите кнопку **h**, пока время на дисплее мигает.
 - Если в течение 2 минут вы ничего не делаете, прибор перейдет в дежурный режим.
12. У вас есть возможность использования таймера для этой программы (см. ТАЙМЕР).
13. Нажмите кнопку .
14. На дисплее будет отображаться обратный отсчет времени.
15. В конце времени приготовления прибор перейдет в режим «поддержания температуры». Загорится индикатор .
16. Нажмите кнопку . Откройте крышку. Извлеките пищевые продукты.



РЫБА

1. Натрите мясо со всех сторон растительным маслом.
2. Посыпьте со всех сторон приправами.
3. Положите столовую ложку растительного масла в чашу.
4. Поместите мясо в чашу.
5. Закройте крышку.
6. Время зависит от размера порции.
7. Не готовьте больше, чем 500 г мяса за один прием.
8. Мы рекомендуем устанавливать время приготовления из расчета 10 минут на каждые 100 г рыбы.
9. С помощью кнопки  установите программу  в меню.
10. Выберите время приготовления. По умолчанию время приготовления составляет 20 минут.
11. Пока время на дисплее мигает, вы можете использовать только кнопки **h** и **min**.
12. Используйте кнопку **min**, чтобы изменить время приготовления на дисплее (возможные варианты: 10, 15, 20, 25, 5, 10, 15, 20, 25, 30, 35, 40, 45, 50 и 55).
13. Если вы хотите готовить более 1 часа, нажмите кнопку **h**.
14. Чтобы отменить установку 1 час, снова нажмите кнопку **h**, пока время на дисплее мигает.
 - Если в течение 2 минут вы ничего не делаете, прибор перейдет в дежурный режим.
15. Когда вы установите время, нажмите .
16. На дисплее будет отображаться обратный отсчет времени.
17. В конце времени приготовления прибор перейдет в режим «поддержания температуры». Загорится индикатор .
18. Лучше всего извлечь продукт сразу после приготовления, чтобы рыба не стала слишком сухой.
19. Нажмите кнопку . Откройте крышку. Извлеките пищевые продукты.

ПРОПАРИВАНИЕ

1. Заполните чашу холодной водой до отметки 6.
2. Поставьте корзину в чашу и положите продукты в корзину.
3. Для равномерной готовки нарежьте продукты на куски примерно одинакового размера.
4. Для гороха, фасоли и аналогичных продуктов сделайте конверт из алюминиевой фольги.
5. Извлекая конверт, соблюдайте осторожность – надевайте кухонные рукавицы и используйте пластмассовые щипцы/ложки.
6. Закройте крышку.
7. С помощью кнопки  установите программу  в меню.
8. Выберите время приготовления. По умолчанию время приготовления составляет 30 минут.
 - Они должны готовиться в течение времени, установленного по умолчанию.

Продукты (свежие)	Количество
зеленая фасоль	200g
Брюссельская капуста	200g
Морковь (ломтиками)	200g
Картофель (четвертями)	400g
Брокколи	200g
Капуста	Четверть
Кукурузные початки	2

9. Пока время на дисплее мигает, вы можете использовать только кнопки h и min.
10. Используйте кнопку min, чтобы изменить время приготовления на дисплее (возможные варианты: 5, 10, 15, 20, 25, 30, 35, 40, 45, 50 и 55).
11. Используйте кнопку h, чтобы изменить время приготовления на дисплее (возможные варианты: 1 и 2).
12. Чтобы отменить установку 1 час, снова нажмите кнопку h, пока время на дисплее мигает.
 - Если в течение 2 минут вы ничего не делаете, прибор перейдет в дежурный режим.
13. У вас есть возможность использования таймера для этой программы (см. ТАЙМЕР).
14. Нажмите кнопку .
15. На дисплее будет отображаться обратный отсчет времени.
16. В конце времени приготовления прибор перейдет в режим «поддержания температуры».
17. Загорится индикатор .
18. Лучше всего извлеките продукт сразу после приготовления, чтобы блюдо не впитало излишнюю влагу.
19. Нажмите кнопку . Откройте крышку. Извлеките пищевые продукты.



• БЖАРИВАНИЕ/ПАССЕРОВАНИЕ/ТУШЕНИЕ/ВАРКА

- Программу ПРОПАРИВАНИЯ  с ее настройкой по умолчанию и открытой крышкой можно использовать как сковороду на большом огне в течение 5, 10, 15, 20, 25, 30 минут перед тем, как включить другую программу для приготовления пищи.
- Используйте ее, добавляя небольшое количество растительного масла для обжаривания мяса и овощей, пассерования лука, сельдерея, лука-порей и т. д.
- Используйте этот режим для предварительного нагрева воды или бульона, необходимых для последующего приготовления блюда.
- При переключении на основную программу прибор будет разогрет и некоторые или все ваши ингредиенты уже будут в чаше.
- В этом случае вам не надо будет мыть кастрюлю, которую вы бы использовали во время приготовления.

КАША/РИЗОТТО





Используйте мерную чашку, чтобы поместить крупу (рис, овсяные хлопья, перловая крупа и т. д.) в чашу.

Каша

- Пользуйтесь правой шкалой с отметками от 1/2 до 1 1/2 на внутренней стороне чаши.
- Не заполняйте чашу выше максимальной отметки (**max**).

Конджи (рисовая каша)





- Пользуйтесь центральной шкалой с отметками от 1 до 3 на внутренней стороне чаши.
 - Не заполняйте чашу выше максимальной отметки (**max**).
1. Наполните чашу водой до отметки, соответствующей количеству чашек используемой крупы.
 2. Закройте крышку.

3. С помощью кнопки  установите программу  в меню.
4. Выберите время приготовления. По умолчанию время приготовления составляет 1 час.
5. Пока время на дисплее мигает, вы можете использовать только кнопки h и min.
6. Используйте кнопку min, чтобы изменить время приготовления на дисплее (возможные варианты: 5, 10, 15, 20, 25, 30, 35, 40, 45, 50 и 55).
7. Используйте кнопку h, чтобы изменить время приготовления на дисплее (возможные варианты: 1, 2, 3 и 4).
8. Чтобы отменить установку 1 час, снова нажмите кнопку h, пока время на дисплее мигает.
 - Если в течение 2 минут вы ничего не делаете, прибор перейдет в дежурный режим.
9. У вас есть возможность использования таймера для этой программы (см. ТАЙМЕР).
10. Нажмите кнопку .
11. На дисплее будет отображаться обратный отсчет времени.
12. В конце времени приготовления прибор перейдет в режим «поддержания температуры». Загорится индикатор .
13. Нажмите кнопку . Откройте крышку. Извлеките пищевые продукты.



Ризотто

Следуйте рецепту, представленному в конце этой брошюры.







ПИРОГ



1. Разморозьте замороженное тесто перед использованием.
2. Не заполняйте чашу более чем наполовину.
3. Смажьте чашу растительным маслом.
4. Поместите тесто в чашу.
5. Закройте крышку.
6. С помощью кнопки  установите программу  в меню.
7. Выберите время приготовления. По умолчанию время приготовления составляет 40 минут.
8. По умолчанию время приготовления составляет 40 минут.
9. Пока время на дисплее мигает, вы можете использовать только кнопки h и min.
10. Используйте кнопку min, чтобы изменить время приготовления на дисплее (возможные варианты: 5, 10, 15, 20, 25, 30, 35, 40, 45, 50 и 55).
11. Используйте кнопку h, чтобы изменить время приготовления на дисплее (возможные варианты: 1 и 2).
12. Чтобы отменить установку 1 час, снова нажмите кнопку h, пока время на дисплее мигает.
 - Если в течение 2 минут вы ничего не делаете, прибор перейдет в дежурный режим.
13. Когда вы установите время, нажмите .
14. На дисплее будет отображаться обратный отсчет времени.
15. В конце времени приготовления прибор перейдет в режим «поддержания температуры». Загорится индикатор .
16. Лучше всего извлек продукт сразу после приготовления, чтобы блюдо не впитало излишнюю влагу.
17. Нажмите кнопку . Откройте крышку. Извлеките пищевые продукты.

ПОДДЕРЖАНИЕ ТЕМПЕРАТУРЫ

- Если вы хотите использовать функцию поддержания температуры после программы, в которой она не предусмотрена, — нажмите , когда единственной индикацией на дисплее будет мигающий значок .
- Нажмите , чтобы выйти из этого режима.

ТАЙМЕР

- Вы можете использовать таймер задержки для программ супа , йогурта , хлеба , пара  и каши .
- Сразу же после установки времени приготовления и до нажатия кнопки пуск  сделайте следующее:

1. Нажмите кнопку . Загорится индикатор .
2. Определите, к которому часу вы хотите иметь готовое блюдо.
3. Например: если сейчас 14:00, а вы хотите, чтобы блюдо было готово в 21:00, вы должны установить время 7 часов.
4. Для выставления правильных показателей часов и минут используйте кнопки **h** и **min** соответственно.
5. Нажмите кнопку .

УХОД И ОБСЛУЖИВАНИЕ

1. Отключите прибор от розетки и дайте ему остыть.
2. Отключите устройство от сети, а затем извлеките соединительный разъем из входного гнезда устройства.
3. При закрытой крышке возьмите фильтр за верхнюю часть и выньте его из крышки (рис. А).
4. Переверните его, чтобы была видна маркировка на переднем крае.
5. Удерживая фиксатор крышки фильтра, поверните остальную часть фильтра в сторону открытого висящего замка  (рис. В).
6. Нажмите на выступы в нижней части внутренней крышки и вытащите ее из прибора. (рис.С).
7. Съемные детали следует мыть вручную.
8. Протрите поверхность чистой влажной тканью.
9. Не опускайте прибор в посудомоечную машину.
10. Соберите фильтр и вставьте его в крышку.
11. Установите внутреннюю крышку в крышку.







ПОВТОРНАЯ ПЕРЕРАБОТКА











Во избежание воздействия вредных веществ на окружающую среду и здоровье приборы и батареи одноразового или многоразового использования, помеченные одним из этих символов, необходимо утилизировать отдельно от несортированных бытовых отходов. Обязательно утилизируйте электрические и электронные изделия, а также (если это применимо) батареи одноразового или многоразового использования в соответствующих официальных пунктах повторной переработки / сбора отходов.









РЕЦЕПТЫ







	столовая ложка (15 мл)
	чайная ложка (5 мл)
g	граммы
ml	миллилитры
	мерная чашка
	стебель/черешок (сельдерея)
	горсть
	яйцо, среднее (53-63г)





	щепотка
	пучок
	веточка
	зубок(-ки)
	консервная банка
	банка
	пакетик (7 г)
	яйцо, большое (63-73г)

ОГНЕННОЕ ЧИЛИ ИЗ ГОВЯДИНЫ ПО-НЬЮ-ЙОРКСКИ





450 g	тушеной говядины
3 	чеснок, очищенный и нарезанный
2 	молотый кумин
1 	кайенский перец
1 	копченой паприки / порошка чипотле
1	зеленый перец
1 	соль
1 	листья базилика, крупно нарезанные

ТУШЕНИЕ

1 	оливковое масло
2	нарезанных луковицы
2 	молотый перец чили
2 	томатного соуса
2 	помидоров
1 	лавровый лист
1 	черный перец
1 	фасоль





Откройте крышку. Добавить масло. Выберите в меню программу  и нажмите . Порежьте говядину, помидоры и перец на маленькие кусочки. Мясо обжарьте, затем выньте. Добавьте лук, чеснок и все травы. Готовьте, пока лук не станет мягким. Добавить мясо. Отложите бобы. Добавьте оставшиеся ингредиенты. Дважды нажмите , чтобы остановить программу. Закройте крышку. Выберите программу . Добавьте бобы за 30 минут до конца приготовления. Если мясо в конце программы все еще жестковатое, добавьте стакан воды и запустите программу для приготовления мяса еще на 30 минут.

ЧИЛИ ИЗ КУСКУСА С ОВОЩАМИ

- 1 нарезанный красный лук
- 1 нарезанный большой репчатый лук
- 2  чеснок, очищенный и нарезанный
- 1 красный перец, без семян, нарезанный
- 1 желтый перец, без семян, нарезанный
- 1  помидоры кусками
- 2  молотый кумин
- 850 ml овощной бульон
- 2  молотый перец чили
- 120-140 ml кускуса
- 1 оранжевый сладкий перец, без семян, нарезанный

для подачи:

- тертый сыр
- немножко сметаны
- небольшой пучок кориандра, нарезанный

Откройте крышку. Добавить масло. Выберите в меню программу  и нажмите . Соедините лук и чеснок. Готовьте, пока лук не станет мягким. Слейте фасоль и добавьте. Отложите кускус. Добавьте оставшиеся ингредиенты. Дважды нажмите , чтобы остановить программу. Закройте крышку. Выберите программу . Добавьте кускус за 30 минут до конца приготовления. Если процесс приготовления уже завершен, выберите в меню программу  и готовьте еще примерно 20 минут. Подавайте в пиале, добавив горсть сыра, немного сметаны и посыпав свежим кориандром. Для классического вегетарианского чили кускус не добавляйте.





ЙОГУРТ СОБСТВЕННОГО ПРИГОТОВЛЕНИЯ

ЙОГУРТ



- 1200 ml молоко
- 100 ml йогурт

вкус по своему усмотрению



- 50 g замороженных летних ягод разных видов
- 1  мед

Откройте крышку. Налейте молоко. Выберите в меню программу  и нажмите . Нагревайте молоко, пока по краям не начнут идти пузырьки. Дважды нажмите , чтобы остановить программу. Охладите молоко до температуры 37—45° С. Смешайте йогурт с молоком. Они должны быть тщательно перемешаны, в противном случае йогурт получится комковатым. Закройте крышку. Выберите в меню программу  и нажмите . Дождитесь окончания выполнения программы. Поместите йогурт в холодильник до полного охлаждения. Слегка подогрейте ягоды в кастрюле. Добавьте мед. Когда ягоды начнут развариваться, снимите с огня, дайте остыть, затем смешайте с йогуртом. Если вы хотите хранить йогурт, банки для него необходимо простерилизовать. Прогрейте их в духовке при 100°С в течение 10 минут. В холодильнике йогурт будет храниться до 2 недель.

ГОРОХОВЫЙ СУП С ГОЛЯШКОЙ

- 1150 ml куриный бульон
- 225 g сушеного гороха половинками
- 1  корень сельдерея, нарезанный
- 1  мелко нарезанного тимьяна
- 1 голяшка

МЕДЛЕННОЕ ПРИГОТОВЛЕНИЕ

- 1 мелко нарезанный лук
- 1 нарезанная морковь
- 2  чеснока (измельченного)
- 1  лавровый лист
- 1 черный перец

Откройте крышку. Добавьте ингредиенты. Выберите в меню программу и нажмите . Доведите до кипения, помешивая. Кипятите на медленном огне в течение 10 минут. Добавьте оставшиеся ингредиенты. Дважды нажмите , чтобы остановить программу. Закройте крышку. Выберите программу . Дождитесь окончания выполнения программы. Выньте голяшку. Удалите кожу и кости. Нарежьте кубиками мясо. Не добавляйте лавровый лист. Разомните горох обратной стороной деревянной ложки. Добавьте мясо. Добавьте приправы и подавайте. Блаженство в чаше!

ТАЖИН ИЗ РЫБЫ ПО-МАРОККАНСКИ

РЫБА

2	чеснок, очищенный и нарезанный	1	нарезанный лук
1	красный перец, без семян, нарезанный	2	помидоры кусками
2	корень сельдерея, нарезанный	1	молотый кумин
1	молотого имбиря	1	куркумы
1	палочка корицы	1	пасты харисса
120 ml	белого вина	1	томатная паста
120 ml	рыбного бульона	1	лимон
675 g	рыба (треска/пикша/филе лосося)	1	зеленых оливок
1	небольшой пучок кориандра, нарезанный		соль и перец

Отложите кориандр. Откройте крышку. Добавьте оставшиеся ингредиенты. Закройте крышку. Выберите в меню программу и нажмите . Готовьте, пока рыба не будет легко расслаиваться (40-60 минут). Дважды нажмите , чтобы остановить программу. Добавьте кориандр. Добавьте приправы и подавайте. Великолепно сочетается с кускусом.

ЛОСОСЬ С ОСТРОЙ КОРОЧКОЙ

РЫБА

2	филе лосося (с кожей)	1	оливковое масло
1	паприка	1	молотый перец чили
1/2	молотый кумин	1	соль и перец
1	мягкого коричневого сахара	1	лимон

Смешайте паприку, порошок чили, кумин, сахар, соль и перец. Посыпьте этой смесью филе лосося. Откройте крышку. Добавьте масло. Выберите в меню программу и нажмите . Подождите пару минут, чтобы растительное масло разогрелось. Добавьте филе кожей вниз. Закройте крышку. Отличное сочетание: пропареная и жареная рыба с хрустящей корочкой! Подавайте с долькой лимона. Великолепное легкое блюдо.

ШОКОЛАДНЫЙ ТОРТ «БРАУНИ»

ПИРОГ

170 g	несоленое сливочное масло	3	
340 g	сахар	1	ванильная эссенция
170 g	порошок какао	1	соль
110 g	капель молочного шоколада	75 g	мука

для подачи:



ванильное мороженое (не обязательно)

Расплавьте в кастрюле масло на медленном огне. Выстелите чашу фольгой, смазанной сливочным маслом. Взбейте в миске растопленное масло, сахар, какао-порошок, муку, яйца, ваниль и соль. Добавьте шоколадные капли. Поместите тесто в фольгу внутри чаши. Закройте крышку. Выберите в меню программу . Установите время приготовления: 1 час 30 минут. Нажмите кнопку . Торт должен быть твердым по краям и слегка клейким в центре. Подавайте торт теплым, положив сверху шарик мороженого.

ПРИГОТОВЛЕННЫЕ НА ПАРУ АРТИШОКИ







ПАР 

1 	чеснок, очищенный и нарезанный	2	артишока
	веточки трав (эстрагон, мята, петрушка, тимьян)	1	лимон

Нарежьте лимон. Обрежьте стебель каждого артишока на уровне нижней части плода. Отрежьте верхнюю четверть от каждого артишока. Удалите все поврежденные листья. Натрите срезанные поверхности ломтиком лимона. Поместите ломтики лимона в корзину. Добавьте веточки трав. Добавьте чеснок. Поместите сверху артишок. Залейте водой до уровня 2 по шкале, размеченной внутри чаши (слева). Поставьте корзину на чашу. Закройте крышку. Выберите в меню программу  и нажмите . Когда внешние листья можно легко удалить, артишоки готовы. Подавайте теплым или холодным с приправой из уксуса. Потрясающе!

ИРЛАНДСКОЕ ЖАРКОЕ (STEW) С КЛЕЦКАМИ ИЗ КОЗЬЕГО СЫРА ТУШЕНИЕ





для жаркого:

1.8 kg	лопатки ягненка (приготовленной)	1 	оливковое масло
250 g	бекон с прослойками жира	3 	чеснока (измельченного)
950 ml	бараньего бульона		соль и перец
1	нарезанный большой репчатый лук	2	нарезанных моркови
2 	корень сельдерея, нарезанный	2 	розмарин, нарезанный
2 	томатная паста	1 	кукурузной муки

для клецок:

100 g	блинная мука	1 	пекарский порошок
50 g	нутряного сала	1 	соль
75 ml	вода	1 	сушеная петрушка
40 g	козий сыр (мягкий)	1 	сушеный чабрец
1 	высушенного майорана	1 	черный перец

для жаркого:

Отделите мясо от костей. Нарежьте мясо и бекон маленькими кусочками. Откройте крышку. Выберите в меню программу  и нажмите . Добавьте ингредиенты. Доведите до кипения, помешивая. Кипятите на медленном огне в течение 10 минут. Слейте бульон в кувшин. Добавьте масло. Добавьте лук и тушить до мягкости. Добавьте мясо, чеснок, травы и другие овощи и варите в течение 5 минут. Добавьте ингредиенты. Добавьте томатное пюре. Дважды нажмите , чтобы остановить программу. Закройте крышку. Выберите программу .

для клецок:

Смешайте все ингредиенты вручную. Сформируйте из смеси 6 шариков. Оставьте на 20 минуты.

в конце:

смешайте в чашке кукурузную муку и небольшое количество воды до однородного состояния. За 30 минут до конца приготовления откройте крышку. Смешайте массу с жарким. Добавьте клецки. Закройте крышку. Дождитесь окончания выполнения программы и подавайте на стол. Превосходное традиционное блюдо!

- Если у вас нет уже готовой баранины, можно использовать сырую, установив программу медленного приготовления вместо программы для тушения, затем продолжить с момента добавления клецок.





АЙНТОПФ ИЗ ПЕРЛОВКИ С ФАСОЛЬЮ БОРЛОТТИ («ВСЕ В ОДНОМ ГОРШКЕ»)

ТУШЕНИЕ 

1 	оливковое масло	1 	фасоли борлотти
175 g	перловой крупы	1	мелко нарезанный лук
1 	помидоры кусками	1 	томатная паста
1000 ml	овощной бульон	2 	петрушка (нарезанная)
125 ml	красного сухого вина		соль и перец

для подачи:





масло чили (не обязательно)



Откройте крышку. Выберите в меню программу  и нажмите . Добавьте ингредиенты. Доведите до кипения, помешивая. Кипятите на медленном огне в течение 10 минут. Слейте бульон в кувшин. Добавьте масло. Добавьте лук и тушите до мягкости. Налейте вино и варите в течение нескольких минут. Добавьте перловую крупу и перемешивайте, пока она не приобретет цвет вина. Слейте фасоль и добавьте. Добавьте помидоры. Добавьте ингредиенты. Дважды нажмите , чтобы остановить программу. Закройте крышку. Выберите программу . За 30 минут до конца приготовления откройте крышку. Проверьте количество жидкости в чаше. Если необходимо, добавьте 150 мл горячей воды. Закройте крышку. Дождитесь окончания выполнения программы. Подавайте со свежим хрустящим хлебом, сбрызнув маслом чили.

ПУДИНГ, ПРОПИТАННЫЙ СИРОПОМ

ПАР 

115 g масло
100 g мелкий сахарный песок
175 g блинная мука
4  золотого сиропа



2  
1/4  ванильная эссенция
2  молоко

Разбейте в миску яйца. Смешайте в чаше сливочное масло и сахар. Постепенно добавляйте яйца, потом ваниль, потом муку. Смешайте с молоком. Смажьте маслом жаропрочную миску объемом 1200 мл. Вылейте сироп на дно жаропрочной миски и выложите смесь сверху. Накройте пергаментом для выпечки, затем фольгой и обвяжите верх шпагатом. Откройте крышку. Поместите жаропрочную миску в чашу в приборе. Добавьте в чашу в приборе кипящей воды до уровня 3 см ниже верха жаропрочной миски. Закройте крышку. Выберите в меню программу . Установите время приготовления: 1 час 30 минут. Нажмите кнопку . Дождитесь окончания выполнения программы. Переверните на блюдо и подавайте теплым. Это отличный пудинг в любое время года!

РИЗОТТО СО СВЕКЛОЙ В МУЛЬТИВАРКЕ

КАША/РИЗОТТО 





400 g свеклы
250 g риса арборио / другого сорта для ризотто
2  чеснок, очищенный и нарезанный
900 ml овощной бульон / куриный бульон

2  оливковое масло
1 мелко нарезанный лук
250 ml белого вина
1  мелко нарезанного тимьяна

в конце:

100 ml йогурт
1  масло

1  петрушка (нарезанная)



Откройте крышку. Выберите в меню программу  и нажмите . Добавьте ингредиенты. Доведите до кипения, помешивая. Кипятите на медленном огне в течение 10 минут. Слейте бульон в кувшин. Дважды нажмите , чтобы остановить программу. Выберите в меню программу  и нажмите . Оставьте ее нагреться. Очистите свеклу и нарежьте кубиками размером 1 см. Поместите свеклу, чеснок и лук в чашу. Готовьте, пока лук не станет мягким. Смешайте с рисом. Закройте крышку и варите в течение 3-4 минут. Откройте крышку. Добавьте вино и перемешайте. Закройте крышку и варите в течение 3-4 минут. Откройте крышку. Добавьте тимьян. Добавьте ингредиенты. Закройте крышку. Дождитесь окончания выполнения программы. Проверьте рис: он должен быть слегка упругим, но не твердым. Если рис не совсем готов, добавьте немного воды и варите еще несколько минут. Смешайте со сливочным маслом — это придаст ризотто блеск. Подавайте с небольшим количеством йогурта, посыпав зеленью петрушки. Это блюдо отлично подходит в качестве закуски или легкого обеда.







БЕЛЫЙ БАТОН

ХЛЕБ 

1  золотого сиропа
320 ml молоко
500 g белая хлебная мука

1  масло
1  сухие дрожжи
1  соль



Откройте крышку. Налейте молоко. Выберите в меню программу  и нажмите . Нагревайте молоко, пока по краям не начнут идти пузырьки. Слейте молоко в кувшин. Дважды нажмите , чтобы остановить программу. Охладите молоко до температуры 37—45° С. Расплавьте в кастрюле масло на медленном огне. Смешайте муку и соль в чаше. Добавьте дрожжи, сливочное масло и сироп. Добавьте молоко и замесите в шар. Если смесь очень липкая, добавьте немного муки. Накройте и оставьте в теплом месте на 10 минут. Вымесите снова. Накройте и оставьте в теплом месте на 10 минут. Откройте крышку. Выберите в меню программу  и нажмите . Закройте крышку. За 30 минут до конца приготовления откройте крышку. Переверните хлеб. Это поможет подрумянить верх батона, чтобы корочка была хрустящей. Дождитесь окончания выполнения программы. Подавайте со сливочным маслом.

ХЛЕБ ИЗ ПРЕСНОГО ТЕСТА

ХЛЕБ 



1  смеси для пресного хлеба
350 ml вода

масло

Откройте крышку. Смажьте чашу сливочным маслом. Выберите в меню программу . Закройте крышку. Установите время приготовления: 2 часа 15 минут. Нажмите кнопку . Оставьте ее нагреться. Высыпьте смесь для пресного хлеба в чашу. Добавьте воды. Вымесите руками в шар. Откройте крышку. Поместите тесто в чашу. Разделите тесто на четыре части пластиковой лопаткой. Закройте крышку. За 30 минут до конца приготовления откройте крышку. Переверните хлеб. Это поможет подрумянить верх батона, чтобы корочка была хрустящей. Дождитесь окончания выполнения программы. Остужайте на решетке. Подавайте с соленым сливочным маслом как отдельное блюдо или с другой едой.

ОВСЯНАЯ КАША

КАША/РИЗОТТО 



2  овсяные хлопья
1/4  соль

вода
2  сахар

для подачи:



жженный сахар

молоко / сливки

Откройте крышку. Добавьте овсяные хлопья, соль и сахар. Залейте водой до уровня 1/2 по шкале, размеченной внутри чаши (справа). Закройте крышку. Выберите в меню программу  и нажмите . Дождитесь окончания выполнения программы. Подавайте с молоком или сливками. Посыпьте жженным сахаром. Если хотите, за 15 минут до конца приготовления можно добавить нарезанную курагу или половинки чернослива (без косточек). Остатки каши можно хранить в холодильнике до 2 дней. Перед подачей нужно разогреть.

ОВСЯНАЯ КАША С ОРЕХАМИ

КАША/РИЗОТТО 



1/2  овсяных хлопьев
120 ml молоко
1  молотая корица

вода
3  кокосовой стружки

для подачи:



золотого сиропа



очищенный миндаль





Откройте крышку. Добавьте овсяные хлопья, корицу, кокосовую стружку и молоко. Залейте водой до уровня 1/2 по шкале, размеченной внутри чаши (справа). Закройте крышку. Выберите в меню программу  и нажмите . Дождитесь окончания выполнения программы. Полейте слегка золотым сиропом и посыпьте сверху миндалем.

СУП ИЗ ЧОРИЗО, КАПУСТЫ И ЯБЛОК

СУП 



- ¼ мелко нарезанной колбасы чоризо
- 1 яблоко
- 2  корень сельдерея, нарезанный
- ¼ мелко нарезанной ранней капусты
- 2  чеснок, очищенный и нарезанный
- 1  соль
- 850 ml овощной бульон



- 1 мелко нарезанный лук
- 2 нарезанных моркови
- 2 помидоры кусками
- 1  томатная паста
- 1  кайенский перец
- 1  черный перец





Откройте крышку. Выберите в меню программу  и нажмите . Обжарьте чоризо в течение 2 минут. Соединить лук и чеснок. Готовьте, пока лук не станет мягким. Яблоко очистите, удалите сердцевину и нарежьте. Добавьте оставшиеся ингредиенты. Дважды нажмите , чтобы остановить программу. Закройте крышку. Выберите в меню программу  и нажмите . Дождитесь окончания выполнения программы. Это отличный суп, и, если вы оставите его на ночь в холодильнике, его вкус станет еще насыщеннее.

СУП ИЗ ПОМИДОРОВ

СУП 

- 1 нарезанный лук
- 1  помидоры кусками
- 1 красный перец, без семян, нарезанный
- 550 ml куриный бульон
- 1  смесь сушеных трав



- 1  оливковое масло
- 2 помидоры кусками
- 2 картофель
- 1  томатная паста
- 1  черный перец

Откройте крышку. Добавьте ингредиенты. Выберите в меню программу  и нажмите . Доведите до кипения, помешивая. Кипятите на медленном огне в течение 10 минут. Слейте бульон в кувшин. Дважды нажмите , чтобы остановить программу. Очистите и нарежьте кубиками картошку. Выберите в меню программу  и нажмите . Добавьте масло. Добавьте лук и сладкий перец. Готовьте, пока лук не станет мягким. Добавьте ингредиенты. Добавьте оставшиеся ингредиенты. Закройте крышку. Дождитесь окончания выполнения программы. Добавьте приправы. Подавайте с хрустящим хлебом.



АППЕТИТНЫЙ РИС

РИС 



- 2  риса
- 1 бульонный кубик (овощной)
- 1 красный перец, без семян, нарезанный
- 2  корень сельдерея, нарезанный





- вода
- 2 нарезанных моркови
- 1  куркумы
- 1  горох (не обязательно)



Откройте крышку. Поместите рис в чашу. Залейте водой до уровня 2 по шкале, размеченной внутри чаши (слева). Раздавите бульонный кубик и размешайте его в воде. Добавьте оставшиеся ингредиенты. Закройте крышку. Выберите программу . Дождитесь окончания выполнения программы и подавайте на стол. Если рис не совсем готов, оставьте его на несколько минут при закрытой крышке пропариться.

КУРИЦА С ПОМИДОРАМИ И ГРИБАМИ

МЯСО 



- 2 куриные грудки, без кожи и костей
- 450 g нарезанных коричневых шампиньонов
- 2  чеснок, очищенный и нарезанный
- 1  Вустерширский соус
- соль и перец



- 1  оливковое масло
- 1  помидоры кусками
- 1  томатного соуса
- 1  сушеный орегано

Откройте крышку. Выберите в меню программу  и нажмите . Добавьте масло. Приправьте куриные грудки солью и перцем и положите их в чашу. Переверните мясо, чтобы оно «схватилось» с обеих сторон. Добавьте чеснок и грибы. Готовьте в течение 3-4 минут, перевернув курицу еще раз. Добавьте помидоры, вустерширский соус, томатный соус и орегано. Продолжайте готовить, перевернув курицу еще раз. Проверьте готовность мяса. Подавайте с макаронами, картофелем или рисом. Быстрое и вкусное блюдо из доступных продуктов.

РЕБРЫШКИ, ТУШЕННЫЕ В ПИВЕ С КЛЕНОВЫМ СИРОПОМ И СОЕВЫМ СОУСОМ









МЯСО 





1 kg	свиной грудинки с ребрышками	1	нарезанный лук
350 ml	пива «Гиннес» или другого крепкого пива	1 	оливковое масло
140 ml	свиного или говяжьего бульона	60 ml	кленового сиропа / мед
3 	чеснок, очищенный и нарезанный	2 	темного соевого соуса

Откройте крышку. Выберите в меню программу . Добавьте масло. Установите время приготовления: 1 час 45 минут. Нажмите кнопку . Добавьте ребрышки и обжаривайте в течение 5 минут, время от времени переворачивая. Выньте ребрышки. Соединить лук и чеснок. Готовьте, пока лук не станет мягким. Положите ребрышки обратно в чашу. Добавьте пиво, бульон, кленовый сироп и соевый соус. Закройте крышку. Дождитесь окончания выполнения программы. Добавьте приправы и подавайте. Отличный вариант для закуски или для обеда из нескольких блюд.

АЙНТОПФ ИЗ ГОВЯЖЕЙ ГРУДИНКИ («ВСЕ В ОДНОМ ГОРШКЕ»)

МЕДЛЕННОЕ ПРИГОТОВЛЕНИЕ 

1 kg	говяжьей грудинки	2 	томатная паста
2 	чеснок, очищенный и нарезанный	2 	лавровый лист
50 g	нарезанной ломтиками колбасы чоризо	2	морковь
2	нарезанных красных луковицы	3 	сельдерей
600 ml	говяжьего бульона	2 	розмарин, нарезанный
2 	смесь сушеных трав	1 	помидоры кусками
6-8	картофель (небольшой)		соль и перец
2 	Вустерширский соус		

Картофель не чистить. Нарежьте картофель, морковь и сельдерей на кусочки. Приправьте грудинку солью и перцем. Откройте крышку. Выберите в меню программу  и нажмите . Добавьте ингредиенты. Доведите до кипения, помешивая. Кипятите на медленном огне в течение 10 минут. Слейте бульон в кувшин. Обжарьте чоризо в течение 2 минут. Добавьте мясо. Обжарьте со всех сторон. Добавьте лук, чеснок, картофель, сельдерей и морковь. Если у вас есть какие-либо другие корнеплоды, которые необходимо использовать, добавьте их тоже. Готовьте, пока лук не станет мягким. Добавьте ингредиенты. Добавьте оставшиеся ингредиенты. Дважды нажмите , чтобы остановить программу. Выберите программу . Дождитесь окончания выполнения программы и подавайте на стол. Готовить в течение 8 часов, но, возможно, блюдо будет готово к употреблению через 5 часов.

Přečtěte si pokyny a uschovejte je. Pokud zařízení předáte dál, předejte ho i s návodem. Před použitím odstraňte všechny obaly.

DŮLEŽITÁ BEZPEČNOSTNÍ OPATŘENÍ

Dodržujte základní bezpečnostní pokyny, jako jsou:

Tento přístroj mohou používat děti ve věku od 8 let a osoby se sníženými fyzickými, sensorickými či mentálními schopnostmi nebo osoby, které výrobek nikdy nepoužívaly nebo jej neznají, pokud tak činí pod dozorem/byly poučeny a rozumí souvisejícím rizikům. S přístrojem si nesmějí hrát děti. Děti nesmějí provádět čištění a běžnou údržbu, pokud nedosáhly věku alespoň 8 let a nejsou-li pod dozorem. Přístroj i kabel uchovávejte mimo dosah dětí mladších 8 let.

Pokud dojde k poškození konektoru nebo kabelu, musí být nahrazeny speciální sadou, která je k dispozici u výrobce nebo v jeho servisním středisku.

 Tento přístroj nepoužívejte v blízkosti van, sprch, umyvadel či jiných nádob obsahujících vodu.

 Nesprávné použití zařízení může vést ke zranění.

 Povrchy přístroje budou pálit. Zbytkové teplo zajistí, že povrchy po použití zůstanou horké.

- Do přístroje nevkládejte zmražené maso či drůbež – napřed tyto potraviny zcela rozmrazte.
- Maso, drůbež a druhotné výrobky (mleté maso, burgery, atd.) připravujeme tak dlouho, dokud výrazně nepouští šťávu. Rybu grilujeme tak dlouho, dokud celkově neztmavne.
- V těle hrnce se nepokoušejte nic vařit, čili vařte pouze ve vyjímatelné míse.
- Neplňte nad max.
- Nezakrývejte spotřebič a nic na něj nestavte.
- Vytáhněte zástrčku ze sítě a potom vypojte konektor ze zdířky v přístroji.
- Když přístroj nepoužíváte, vytáhněte jej ze sítě.
- Nepoužívejte příslušenství nebo nástavce mimo těch, které dodáváme my.
- Nepoužívejte spotřebič pro jiný účel, než je uvedeno v těchto pokynech.
- Nepoužívejte spotřebič, je-li poškozen nebo se objevují poruchy.

JEN PRO DOMÁCÍ POUŽITÍ

NÁKRESY

- | | |
|---------------------------|-------------|
| 1. Ovládací panel | 5. Odměrka |
| 2. Poklice | 6. Koš |
| 3. Zámek poklice | 7. Mísa |
| 4. Vnitřní strana poklice | 8. Konektor |



PŘÍPRAVA

1. Umístěte spotřebič na stabilní, rovnou plochu odolnou vůči teple.
2. Přístroj nepoužívejte blízko záclon a závěsů nebo pod policemi či skřínkami nebo blízko něčeho, co se může působením unikající páry poškodit.
3. Mějte vždy připravené rukavice na pečení (nebo utěrku) a tepelně odolnou podložku nebo mělký



talíř, na který po skončení vaření mísu položíte.

4. Vložte mísu do hrnce.
5. Mísou pootočte o čtvrt otáčky do obou směrů, abyste se ujistili, že je mezi spodkem mísy a topným tělesem dobrý kontakt.



RÝŽE

1. Rýži nasypete do mísy pomocí odměrky.
2. Nedávejte více než 10 šálků rýže.
3. Použijte stupnici na levé straně uvnitř mísy, je označena čísly 2 až 10.
4. Mísu naplňte vodou až k číslu, které odpovídá počtu nasypaných šálků rýže.
5. Víko uzavřete.
6. Stiskněte  tlačítko. Tlačítko se rozsvítí.
7. Vnější části displeje budou během nahřívání potravin blikat.
8. Na displeji se následně zobrazí zbývající čas vaření (13 minut), a začne odpočítávání.
9. Po skončení nastaveného času vaření se přístroj přepne do režimu „stále teplé“.
10. Rozsvítí se kontrolka .
11. Otevřete víko.
12. Vyměňte mísu a položte ji na tepelně odolnou podložku nebo mělký talíř.
13. Stiskněte  tlačítko.
14. Lopatkou rýži prokypřete a promíchejte, aby unikla zbývající pára.
15. Občas se stane, že na vrstvě rýže, která je v kontaktu s mísou, se utvoří krusta.
16. Pokud ovšem o krustu zájem nemáte, můžete ji odstranit pomocí lopatky hned poté, co rýži naberete na talíř.

POMALÉ VAŘENÍ





1. Maso a zeleninu opečte dozlatova (viz “DOZLATOVA/NA PRUDKO/DO ZMĚKNUTÍ/DO VARU”).
2. Tekutou část uveďte do varu (viz “DOZLATOVA/NA PRUDKO/DO ZMĚKNUTÍ/DO VARU”).
3. Vložte do mísy pevné ingredience, potom přidejte tekutou část.
4. Víko uzavřete.
5. Stiskněte  tlačítko. Tlačítko se rozsvítí.
6. Na displeji se zobrazí 8 hodin a začne odpočítávání.
7. Po skončení nastaveného času vaření se přístroj přepne do režimu „stále teplé“.
8. Rozsvítí se kontrolka .
9. Stiskněte  tlačítko. Otevřete víko. Jídlo vyjměte.

DUŠENÍ





1. Maso a zeleninu opečte dozlatova (viz “DOZLATOVA/NA PRUDKO/DO ZMĚKNUTÍ/DO VARU”).
2. Tekutou část uveďte do varu (viz “DOZLATOVA/NA PRUDKO/DO ZMĚKNUTÍ/DO VARU”).
3. Vložte do mísy pevné ingredience, potom přidejte tekutou část.
4. Víko uzavřete.
5. Stiskněte  tlačítko. Tlačítko se rozsvítí.
6. Na displeji se zobrazí 1 hodina a začne odpočítávání.
7. Po skončení nastaveného času vaření se přístroj přepne do režimu „stále teplé“.
8. Rozsvítí se kontrolka .
9. Stiskněte  tlačítko. Otevřete víko. Jídlo vyjměte.

MASO

1. Maso potřete ze všech stran olejem na vaření.
2. Na povrchu maso potřete kořením.
3. Do mísy dejte jednu polévkovou lžici oleje na vaření.
4. Maso vložte do mísy.

5. Víko uzavřete.
6. Čas se odvíjí od velikosti jídla.
7. Nevařte najednou více než asi 500 g masa.
8. Navrhujeme čas pečení 10 minut + 10 minut na 100 g váhy hovězího.
9. Vepřové či drůbež pečte minimálně 5, 10, 15, 20, 25, 30 minut.
10. Pomocí tlačítka  zvolte v menu .
11. Zvolte čas pečení. Původní nastavení je 20 minut.
12. Tlačítka h a min lze použít pouze tehdy, když čas na displeji bliká.
13. Pomocí tlačítka min procházejte možnostmi na displeji (10, 15, 20, 25, 5, 10, 15, 20, 25, 30, 35, 40, 45, 50 a 55).
14. Pokud chcete vařit/péct 1 hodinu, stiskněte tlačítko h.
15. Nastavení 1 hodiny zrušíte tak, že opětovně stisknete tlačítko h, a to tehdy, když čas na displeji bliká.
 - Pokud nebudete dělat nic po dobu 2 minut, přístroj se vrátí do pohotovostního režimu.
16. Po nastavení času stisknete .
17. Na displeji začne odpočítávání.
18. Po skončení nastaveného času vaření se přístroj přepne do režimu „stále teplé“.
19. Rozsvítí se kontrolka .
20. Stiskněte  tlačítko. Otevřete víko. Jídlo vyjměte.

POLÉVKA

1. Maso a zeleninu opečte dozlatova (viz “DOZLATOVA/NA PRUDKO/DO ZMĚKNUTÍ/DO VARU”).
2. Vložte do mísy pevné ingredience, potom přidejte tekutou část.
3. Víko uzavřete.
4. Pomocí tlačítka  zvolte v menu .
5. Zvolte čas pečení. Původní nastavení je 1 hodina.
6. Tlačítka h a min lze použít pouze tehdy, když čas na displeji bliká.
7. Pomocí tlačítka min procházejte možnostmi na displeji (10, 15, 20, 25, 5, 10, 15, 20, 25, 30, 35, 40, 45, 50 a 55).
8. Pomocí tlačítka h procházejte možnostmi na displeji (1, 2, 3, 4 a 5).
9. Nastavení 5 hodiny zrušíte tak, že opětovně stisknete tlačítko h, a to tehdy, když čas na displeji bliká.
 - Pokud nebudete dělat nic po dobu 2 minut, přístroj se vrátí do pohotovostního režimu.
10. U tohoto programu máte možnost použít časovač (viz ČASOVAČ).
11. Stiskněte  tlačítko.
12. Na displeji začne odpočítávání.
13. Po skončení nastaveného času vaření se přístroj přepne do režimu „stále teplé“.
14. Rozsvítí se kontrolka .
15. Stiskněte  tlačítko. Otevřete víko. Jídlo vyjměte.

JOGURT

Jogurtová kultura

Můžete použít 5, 10, 15, 20, 25, 30 ml (2 polévkové lžíce):

- Neochuceného živého jogurtu – musí být čerstvý (hledejte jogurt s dlouhou dobou spotřeby).
S různými značkami docílíte různých výsledků.

Jogurtu, který jste dělali předtím.

- Bakterie se časem oslabí, čili takto můžete postupovat jen 10krát a pak musíte použít novou kulturu.
- Sublimačně sušené jogurtové kultury z lékárny nebo z obchodu se zdravým jídlem
- Pokud pokyny na balení s kulturou jsou jiné než v tomto návodu, řiďte se podle pokynů na balení.





Mléko

- Budete potřebovat 1 litr mléka.
- Z plnotučného mléka získáte hustší jogurt než z polotučného mléka.
- Aby byl jogurt ještě hustší, můžete do tekutého mléka přidat až 8 polévkových lžic mléka v prášku.







- Také můžete použít mléko namíchané z prášku nebo kondenzované mléko z konzervy.

Výroba jogurtu





1. Bakterii v mléku musíte zabít, aby nereagovala s bakterií v jogurtové kultuře.
2. Zatímco budete ohřívat mléko, nechte jogurtovou kulturu zahřát na pokojovou teplotu.
3. Otevřete víko.
4. Pomocí programu VAŘENÍ V PÁŘE (DOZLATOVA/NA PRUDKO/DO ZMĚKNUTÍ/DO VARU) ohřejte mléko na teplotu přesně před varem.
5. Mléko ohřívejte tak dlouho, dokud se nezačnou u kraji tvořit bublinky.
6. Mléko nechte vychladnout na teplotu mezi 37°C a 45°C.
7. Jogurtovou kulturu vmíchejte do mléka.
8. Musí dojít k dokonalému promíchání, jinak by byly v jogurtu hrudky.
9. Víko uzavřete.
10. Pomocí tlačítka  zvolte v menu .
11. Zvolte čas pečení. Původní nastavení je 8 hodin.
12. Tlačítka h a min lze použít pouze tehdy, když čas na displeji bliká.
13. Pomocí tlačítka min procházejte možnosti na displeji (10, 15, 20, 25, 5, 10, 15, 20, 25, 30, 35, 40, 45, 50 a 55).
14. Pomocí tlačítka h procházejte možnosti na displeji (6, 7, 8, 9 a 10).
15. Nastavení 10 hodiny zrušíte tak, že opětovně stisknete tlačítko h, a to tehdy, když čas na displeji bliká.
- Pokud nebudete dělat nic po dobu 2 minut, přístroj se vrátí do pohotovostního režimu.
16. U tohoto programu máte možnost použít časovač (viz ČASOVAČ).
17. Stiskněte  tlačítko.
18. Na displeji začne odpočítávání.
19. Po skončení nastaveného času vaření se přístroj přepne do pohotovostního režimu.
20. Jogurt se teplý udržovat nebude.
21. Stiskněte  tlačítko. Otevřete víko. Jídlo vyjměte.

CHLĚB



1. Před použitím mražené těsto zcela rozmrazte.
2. Nevařte najednou více než asi 500 g masa.
3. Mísu vymažte olejem na vaření.
4. Vložte těsto do mísy.
5. Víko uzavřete.
6. Pomocí tlačítka  zvolte v menu .
7. Zvolte čas pečení. Původní nastavení je 3 hodin.
8. Tlačítka h a min lze použít pouze tehdy, když čas na displeji bliká.
9. Pomocí tlačítka min procházejte možnosti na displeji (10, 15, 20, 25, 5, 10, 15, 20, 25, 30, 35, 40, 45, 50 a 55).
10. Pomocí tlačítka h procházejte možnosti na displeji (1, 2, 3, 4, 5 a 6).
11. Nastavení 6 hodiny zrušíte tak, že opětovně stisknete tlačítko h, a to tehdy, když čas na displeji bliká.
- Pokud nebudete dělat nic po dobu 2 minut, přístroj se vrátí do pohotovostního režimu.
12. U tohoto programu máte možnost použít časovač (viz ČASOVAČ).
13. Stiskněte  tlačítko.
14. Na displeji začne odpočítávání.
15. Po skončení nastaveného času vaření se přístroj přepne do režimu „stále teplé“.
16. Rozsvítí se kontrolka .
17. Stiskněte  tlačítko. Otevřete víko. Jídlo vyjměte.

RYBA

1. Maso potřete ze všech stran olejem na vaření.
2. Na povrchu maso potřete kořením.
3. Do mísy dejte jednu polévkovou lžici oleje na vaření.

4. Maso vložte do mísy.
5. Víko uzavřete.
6. Čas se odvíjí od velikosti jídla.
7. Nevařte najednou více než asi 500 g masa.
8. Navrhujeme čas pečení 10 minut na 100 g váhy.
9. Pomocí tlačítka  zvolte v menu .
10. Zvolte čas pečení. Původní nastavení je 20 minut.
11. Tlačítka h a min lze použít pouze tehdy, když čas na displeji bliká.
12. Pomocí tlačítka min procházejte možnostmi na displeji (10, 15, 20, 25, 5, 10, 15, 20, 25, 30, 35, 40, 45, 50 a 55).
13. Pokud chcete vařit/péct 1 hodinu, stiskněte tlačítko h.
14. Nastavení 1 hodiny zrušíte tak, že opětovně stisknete tlačítko h, a to tehdy, když čas na displeji bliká.
- Pokud nebudete dělat nic po dobu 2 minut, přístroj se vrátí do pohotovostního režimu.
15. Po nastavení času stisknete .
16. Na displeji začne odpočítávání.
17. Po skončení nastaveného času vaření se přístroj přepne do režimu „stále teplé“.
18. Rozsvítí se kontrolka .
19. Nejlepší je jídlo vytáhnout, jakmile je hotové, abychom zabránili jeho vysušení.
20. Stiskněte  tlačítko. Otevřete víko. Jídlo vyjměte.

VAŘENÍ V PÁŘE

1. Do mísy nalijte studenou vodu po značku 6.
2. Koš umístěte na horní část mísy, do koše pak umístěte jídlo.
3. Aby se potraviny udělaly stejnoměrně, nakrájejte je přibližně na stejné veliké kousky.
4. Potraviny, které by se mohly rozpadnout a propadnout do vody, či potraviny malých rozměrů (např. hrášek), zabalte do alobalu.
5. Při vyjímání zabalených potravin buďte opatrní – používejte rukavice na pečení a plastové kleště/lžíce.
6. Víko uzavřete.
7. Pomocí tlačítka  zvolte v menu .
8. Zvolte čas pečení. Původní nastavení je 30 minut.
- Tyto ingredience by se měly vařit v původně nastaveném čase:

Potraviny (čerstvé)	Množství
Zelené fazolky	200g
Růžičková kapusta	200g
Mrkev (na plátky)	200g
Brambory (na čtvrtky)	400g
Brokolice	200g
Zelí	čtvrtka
Kukuřičné klasy	2

9. Tlačítka h a min lze použít pouze tehdy, když čas na displeji bliká.
10. Pomocí tlačítka min procházejte možnostmi na displeji (5, 10, 15, 20, 25, 30, 35, 40, 45, 50 a 55).
11. Pomocí tlačítka h procházejte možnostmi na displeji (1 a 2).
12. Nastavení 2 hodiny zrušíte tak, že opětovně stisknete tlačítko h, a to tehdy, když čas na displeji bliká.
- Pokud nebudete dělat nic po dobu 2 minut, přístroj se vrátí do pohotovostního režimu.
13. U tohoto programu máte možnost použít časovač (viz ČASOVAČ).
14. Stiskněte v tlačítko.
15. Na displeji začne odpočítávání.



- Po skončení nastaveného času vaření se přístroj přepne do režimu „stále teplé“.
- Rozsvítí se kontrolka W.
- Nejlepší je dort vytáhnout, jakmile je hotový, abychom zabránili jeho rozbřednutí.
- Stiskněte w tlačítko. Otevřete víko. Jídlo vyjměte.

DOZLATOVA/NA PRUDKO/DO ZMĚKNUTÍ/DO VARU

- Program VAŘENÍ V PÁŘE  můžete v původním nastavení používat s otevřenou poklicí jako vysokoteplotní pánev po dobu 5, 10, 15, 20, 25, 30 minut, než použijete další program.
- V tomto režimu při pečení masa a zeleniny dozlatova, pečení na prudko či do změknutí (cibule, celer, pórek atd.) používejte jen trochu oleje.
- V tomto režimu lze přístroj používat i k předeřhnutí tekutin, čili s vodou nebo vývarem.
- Po přepnutí na hlavní program už bude přístroj zahřátý a některé nebo všechny ingredience již v míse.
- Pak není třeba umývat pánev, kterou byste během vaření jinak museli použít.





KAŠE/RIZOTO

Nasypte do mísy pomocí odměrky obilovinu (rýže, oves, ječmen atd.).

Kaše

- Použijte stupnici na pravé straně uvnitř mísy, je označena od ½ do 1½.
- Nepněte nad **max**.



Congee

- Použijte prostřední stupnici uvnitř mísy, je označena od 1 do 3.
 - Nepněte nad **max**.
- Mísu naplňte vodou až k číslu, které odpovídá počtu nasypných šálků s obilovinou.
 - Víko uzavřete.
 - Pomocí tlačítka  zvolte v menu .
 - Zvolte čas pečení. Původní nastavení je 1 hodina.
 - Tlačítka h a min lze použít pouze tehdy, když čas na displeji bliká.
 - Pomocí tlačítka min procházejte možnosti na displeji (5, 10, 15, 20, 25, 30, 35, 40, 45, 50 a 55).
 - Pomocí tlačítka h procházejte možnosti na displeji (1, 2, 3 a 4).
 - Nastavení 4 hodiny zrušíte tak, že opětovně stisknete tlačítko h, a to tehdy, když čas na displeji bliká.
 - Pokud nebudete dělat nic po dobu 2 minut, přístroj se vrátí do pohotovostního režimu.
 - U tohoto programu máte možnost použít časovač (viz ČASOVAČ).
 - Stiskněte  tlačítko.
 - Na displeji začne odpočítávání.
 - Po skončení nastaveného času vaření se přístroj přepne do režimu „stále teplé“.
 - Rozsvítí se kontrolka .
 - Stiskněte  tlačítko. Otevřete víko. Jídlo vyjměte.

Rizoto

- Postupujte podle receptu uvedeného v další části tohoto návodu.

DORT

- Před použitím mražené těsto zcela rozmrazte.
- Mísu neplňte více než asi z poloviny.
- Mísu vymažte olejem na vaření.
- Vložte těsto do mísy.
- Víko uzavřete.
- Pomocí tlačítka  zvolte v menu .
- Zvolte čas pečení. Původní nastavení je 40 minut.
- Původní nastavení je 40 minut.
- Tlačítka h a min lze použít pouze tehdy, když čas na displeji bliká.
- Pomocí tlačítka min procházejte možnosti na displeji (5, 10, 15, 20, 25, 30, 35, 40, 45, 50 a 55).
- Pomocí tlačítka h procházejte možnosti na displeji (1 a 2).

12. Nastavení 2 hodiny zrušíte tak, že opětovně stisknete tlačítko h, a to tehdy, když čas na displeji bliká.
- Pokud nebudete dělat nic po dobu 2 minut, přístroj se vrátí do pohotovostního režimu.
13. Po nastavení času stisknete ◊.
14. Na displeji začne odpočítávání.
15. Po skončení nastaveného času vaření se přístroj přepne do režimu „stále teplé“.
16. Rozsvítí se kontrolka ☹.
17. Nejlepší je dort vytáhnout, jakmile je hotový, abychom zabránili jeho rozbřednutí.
18. Stiskněte ⏏ tlačítko. Otevřete víko. Jídlo vyjměte.

STÁLE TEPLÉ

- Pokud si přejete použít funkci „stále teplé“ po programu, který ji nepodporuje, potom, pokud je na displeji zobrazena pouze blikající kontrolka ☹, stiskněte ☹.
- Stisknutím ⏏ funkci zrušíte.

ČASOVAČ ⏰

- U programů polévka 🍲, jogurt 🥛, chléb 🍞, pára 🍲 a kaše 🍲 můžete použít časovač zpoždění.
- Tento krok proveďte ihned po nastavení času vaření a před stisknutím tlačítka start ◊:

 1. Stiskněte ⏰ tlačítko. Rozsvítí se kontrolka ⏰.
 2. Rozhodněte se, na kdy chcete mít jídlo připravené.
 3. Příklad: Nyní jsou 14:00 a vy chcete mít jídlo připravené na 21:00, čili musíte nastavit čas na 7 hodin.
 4. Pro nastavení správného času použijte tlačítka h a min.
 5. Stiskněte ⏏ tlačítko.

PÉČE A ÚDRŽBA

1. Přístroj vypojte ze sítě a nechte vychladnout.
2. Vytáhněte zástrčku ze sítě a potom vypojte konektor ze zdířky v přístroji.
3. Přiklopte poklici a uchopte filtr za jeho horní část a z poklice jej vyjměte pákovým pohybem (Obr. A).
4. Otočte jej, abyste viděli značky na předním okraji.
5. Pevně uchopte víko filtru a druhou částí filtru pootočte k symbolu otevřeného zámku 🗝 (Obr. B).
6. Stiskněte západky na spodní straně vnitřní části poklice a z přístroje ji vyjměte (Obr. C).
7. Ručně umyjte snímatelné díly.
8. Všechny plochy otřete čistým vlhkým hadrem.
9. Nevkládejte žádnou část spotřebiče do myčky.
10. Filtr složte zpátky a znovu jej vložte do poklice.
11. Vložte vnitřní část poklice zpět do poklice.







RECYKLACE











Aby nedocházelo k ničení životního prostředí a zdraví kvůli obsaženým nebezpečným látkám, přístroje a dobíjecí i nedobíjecí baterie označené jedním z těchto symbolů nesmějí být vyhazovány do smíšeného komunálního odpadu. Elektrické a elektronické výrobky, a pokud to přísluší, i dobíjecí i nedobíjecí baterie, vždy likvidujte na oficiálním recyklačním/sběrném místě.









RECEPTY

	polévková lžíce (15 ml)
	čajová lžička (5 ml)
g	gramy
ml	mililitry
	odměrka
	stonky (celeru)
	hrst
	vejce, střední (53-63 g)



	špetka
	trs
	snítka
	stroužek (stroužky)
	plechovka
	sklenice
	sáček (7 g)
	vejce, velké (63-73 g)

HRACHOVÁ POLÉVKA S VEPŘOVÝM KOLENEM





1150 ml	kuřecí vývar
225 g	loupaný hrách
1 	celer, nakrájený
1 	tymián, najemno nasekaný
1	vepřové koleno

Otevřete víko. Přidejte vývar. V menu zvolte  a stiskněte . Přiveďte k varu za stálého míchání. Zvolna vařte 10 minut. Přidejte zbývající ingredience. Dvakrát stiskněte , čímž se program zastaví. Víko uzavřete. Zvolte . Počkejte, až program doběhne. Vepřové koleno vyjměte. Zbavte jej kůže a kostí. Maso nakrájejte na kostky. Odstraňte bobkový list. Loupaný hrách rozmáčkejte zadní stranou vařečky. Přidejte maso. Dochutěte kořením a podávejte. Je to delikatesa!



POMALÉ VAŘENÍ

1	cibule, najemno nakrájená
1	mrkev, na kostičky
2 	česnek (rozdrcený)
1 	bobkový list
	černý pepř

ZELENINOVÉ CHILLI S KUSKUSEM





1	červená cibule, na kostičky
1	velká cibule, na kostičky
2 	česnek, oloupaný a nakrájený
1	červená paprika, zbavená semen a nakrájená
1	žlutá paprika, zbavená semen a nakrájená
1	oranžová paprika, zbavená semen a nakrájená
1 	mletý koriandr
1 	rajský protlak
850 ml	zeleninový bujón
2 	pálivá rajčatová omáčka
120-140 ml	kuskus

POMALÉ VAŘENÍ

1 	olivový olej
1 	máslové fazole
1 	fazole cannellini
1 	zelené jalapeños
1 	fazole
1 	rajčata na kousky
2 	mletý římský kmín
1 	cukr
2 	mletá chilli paprika
2 	sušené oregáno

podávání:

nastrouhaný sýr	zakysaná smetana
malý trs koriandru, nakrájený	

Otevřete víko. Přidejte olej. V menu zvolte  a stiskněte . Přidejte cibuli a česnek. Cibuli vařte do změknutí. Slijte fazole a přidejte je do mísy. Kuskus si nachystejte stranou. Přidejte zbývající ingredience. Dvakrát stiskněte , čímž se program zastaví. Víko uzavřete. Zvolte . Kuskus přidejte 30 minut před koncem vaření. Pokud čas vaření již uplynul, zvolte v menu  a vařte dalších asi 20 minut. Podávejte v misce, nahoru dejte hrst sýra, pokapejte zakysanou smetanou a poprašte čerstvým koriandrem. U klasického vegetariánského chilli kuskus vynechejte.

DOMÁCÍ JOGURT

JOGURT





1200 ml mléko

100 ml jogurt

různé příchutě

50 g mražená směs ovocných bobulí

1  med

Otevřete víko. Přidejte mléko. V menu zvolte  a stiskněte . Mléko ohřívejte tak dlouho, dokud se nezačnou u krajų tvořit bublinky. Dvakrát stiskněte , čímž se program zastaví. Mléko nechte vychladnout na teplotu mezi 37°C a 45°C. Vmíchejte jogurt do mléka. Musí dojít k dokonalému promíchání, jinak by byly v jogurtu hrudky. Víko uzavřete. V menu zvolte  a stiskněte . Počkejte, až program doběhne. Jogurt dejte do lednice zcela vychladit. Bobule jemně ohřejte na pánvi. Přidejte med. Když se bobule začínou rozpadat, odstavte je a nechte vychladnout, pak smíchejte s jogurtem. Pokud chcete jogurt uskladnit, musíte sklenice, které chcete použít, sterilizovat. Dejte je do trouby na 10 minut nahřát na 100°C. Jogurt v lednici vydrží až 2 týdny.

PÁLIVÉ HOVĚZÍ CHILLI Á LA NEW YORK

DUŠENÍ

450 g hovězí maso na dušení

1  olivový olej

3  česnek, oloupaný a nakrájený

2 cibule, na kostičky

2  mletý římský kmín

2  mletá chilli paprika

1  kajenský pepř

2  rajčatová omáčka

1  uzená paprika/mletá paprička chipotle

2  rajčata

1 zelená paprika





1  bobkový list

1  sůl

1  černý pepř

1  lístky bazalky, nahrubo nakrájené

1  fazole

Otevřete víko. Přidejte olej. V menu zvolte  a stiskněte . Hovězí, rajčata a papriku nakrájejte na takové kousky, které se dají dobře jíst. Maso opečte dozlatova a potom vyndejte. Přidejte cibuli, česnek a všechny bylinky. Cibuli vařte do změknutí. Přidejte maso. Fazole si nachystejte stranou. Přidejte zbývající ingredience. Dvakrát stiskněte , čímž se program zastaví. Víko uzavřete. Zvolte . Fazole přidejte 30 minut před skončením vaření. Pokud se maso na konci programu zdá být pořád ještě tuhé, přidejte sklenici vody a program k přípravě masa nastavte ještě na dalších 30 minut.

MAROCKÝ RYBÍ TAŽIN

RYBA

2  česnek, oloupaný a nakrájený

1 cibule, na kostičky

1 červená paprika, zbavená semen a nakrájená

2  celer, nakrájený

2 rajčata na kousky

1  mletý římský kmín

1  mletý zázvor

1  kurkuma

1 celá skořice

1  pasta harissa

120 ml bílé víno

1  rajský protlak

120 ml rybí vývar



1 citron

675 g ryba (treska/lososa)

1  zelené olivy

1 malý trs koriandru, nakrájený

sůl a pepř

Koriandr si nachystejte stranou. Otevřete víko. Přidejte zbývající ingredience. Víko uzavřete. V menu zvolte  a stiskněte . Vařte, dokud nepůjde ryba snadno rozebrat (40-60 minut). Dvakrát stiskněte , čímž se program zastaví. Přidejte koriandr. Dochutte kořením a podávejte. Výborné se k tomu hodí kusus.

LOSOS NA OSTRÉM KOŘENÍ

RYBA

2 filety z lososa (s kůží)

1  olivový olej

1  paprika



1  mletá chilli paprika

½  mletý římský kmín

1  sůl a pepř



1  jemný hnědý cukr

1 citron

Smíchejte papriku, chilli koření, římský pepř, cukr, sůl a pepř. Filety z lososa posypte kořením. Otevřete víko. Přidejte olej. V menu zvolte  a stiskněte . Počkejte několik minut, aby se olej rozehrál. Filety vložte kůží dolů. Víko uzavřete. Jde o skvělou kombinaci, kdy se ryba vaří v páře a smaží, čili kůžička je pak krásně křupavá. Podávejte s měsíčkem citronu. Je to výborné lehké jídlo.



ČOKOLÁDOVÝ DORT BROWNIE

DORT 

170 g	neosolené máslo	3	
340 g	cukr	1	 esence vanilky
170 g	kakaový prášek	1	 sůl
110 g	kousky mléčné čokolády (dropsy)	75 g	jemná pšeničná mouka

podávání:





vanilková zmrzlina (volitelné)

Na malém plameni rozpustíte v hrnci máslo. Mísu vyložíte alobalem a vymažete máslem. V talíři rozkvedlejte rozpuštěné máslo, cukr, kakaový prášek, mouku, vejce, vanilku a sůl. Přimíchejte čokoládové kousky. Těsto nalijte na alobal v míse. Víko uzavřete. V menu zvolte . Čas pečení nastavte na 1 hodinu a 30 minut. Stiskněte  tlačítko. Dort by měl být na okrajích pevný a uprostřed lehce mazlavý. Dort podávejte teplý a nahoru dejte zmrzlinu.

BÍLÝ CHLĚB

CHLĚB 



1	 zlatý sirup	1	 máslo
320 ml	mléko	1	 sušené kvasnice
500 g	silná bílá chlebová mouka	1	 sůl

Otevřete víko. Nalijte mléko. V menu zvolte  a stiskněte . Mléko ohřívajte tak dlouho, dokud se nezačnou u krajů tvořit bublinky. Mléko přelijte do džbánu. Dvakrát stiskněte , čímž se program zastaví. Mléko nechte vychladnout na teplotu mezi 37°C a 45°C. Na malém plameni rozpustíte v hrnci máslo. V misce smíchejte mouku se solí. Přidejte droždí, máslo a sirup. Přidejte mléko a uhnětte bochník. Pokud se směs příliš lepí, přidejte trochu více mouky. Přikryjte a nechte odpočívat v teple 10 minut. Znovu hnětte. Přikryjte a nechte odpočívat v teple 10 minut. Otevřete víko. V menu zvolte  a stiskněte . Víko uzavřete. 30 minut před ukončením nastaveného času vaření poklici otevřete. Chléb otočte z druhé strany. To proto, aby se horní část bochníku také trochu zbarvila a byla křupavá. Počkejte, až program doběhne. Podávejte potřené máslem.

SODOVÝ CHLĚB

CHLĚB 

1	 směs na sodový chléb	máslo
350 ml	voda	

Otevřete víko. Mísu vymažte máslem. V menu zvolte . Víko uzavřete. Čas pečení nastavte na 2 hodiny a 15 minut. Stiskněte  tlačítko. Nechte přístroj zahřát. Do misky vložte směs na sodový chléb. Nalijte vodu. Ručně hnětte, až vytvoříte bochník. Otevřete víko. Těsto vložte do mísy. Pomocí plastové stěrky těsto rozdělte na čtvrtiny. Víko uzavřete. 30 minut před ukončením nastaveného času vaření poklici otevřete. Chléb otočte z druhé strany. To proto, aby se horní část bochníku také trochu zbarvila a byla křupavá. Počkejte, až program doběhne. Nechte vychladnout na kovové mřížce. Podávejte potřené slaným máslem samostatně nebo jako přílohu k jídlu.

IRSKÁ STEW (DUŠENÁ) SMĚS S KNEDLÍKY Z KOZÍHO SÝRA

DUŠENÍ 

na dušenou směs:

1.8 kg	jehněčí plec (vařená)	1	 olivový olej
250 g	prorostlá slanina	3	 česnek (rozdrcený)
950 ml	jehněčí vývar		sůl a pepř
1	velká cibule, na kostičky	2	mrkev, na kostičky
2	 celer, nakrájený	2	 rozmarýn, nasekaný
2	 rajský protlak	1	 kukuřičná mouka

na knedlíky:

100 g	samokynoucí mouka	1	 prášek do pečiva
50 g	lůj	1	 sůl
75 ml	voda	1	 sušená petržel
40 g	kozí sýr (jemný)	1	 sušený tymián
1	 sušená majoránka	1	 černý pepř

na dušenou směs:

Maso oberte od kosti. Maso a slaninu nakrájejte na takové kousky, které se dají dobře jíst. Otevřete víko. V menu zvolte ☰ a stiskněte ◊. Přidejte vývar. Přiveďte k varu za stálého míchání. Zvolna vařte 10 minut. Vývar přelijte do nějakého džbánu. Přidejte olej. Přidejte cibuli a lehce osmažte. Přidejte maso, česnek, bylinky a další zeleninu a nechte 5 minut vařit. Přidejte vývar. Přidejte rajčatový protlak. Dvakrát stiskněte Ⓢ, čímž se program zastaví. Víko uzavřete. Zvolte ☰.

na knedlíky:

Všechny ingredience rukou promíchejte. Ze směsi uváležte 6 knedlíků. Nechte 20 minut odpočívat.

na závěr:

Z kukuřičné mouky a trochy vody udělejte v hrnku jemnou pastu. 30 minut před ukončením nastaveného času vaření poklici otevřete. Pastu vmíchejte do dušené směsi. Přidejte knedlíky. Poklici zavřete. Počkejte, až program doběhne, a potom podávejte. Čeká vás velký nášup skvělého jídla!

- Pokud nemáte žádné jehněčí uvařené, můžete použít i syrové jehněčí, ovšem v programu pomalého vaření namísto programu pro dušení. Od knedlíků je potom postup už stejný.

ARTYČOK V PÁŘE

PÁRA ☰

1 🍷	česnek, oloupaný a nakrájený	2	artyčoky kardové
	snítky bylinek (estragon, máta, petržel, tymián)	1	citron

Citron nakrájejte na plátky. Vespod každého artyčoku odřežte rovně stonky. Odřežte horní čtvrtinu každého artyčoku. Poškozené listy odstraňte. Plochy po ořezu potřete plátkem citronu. Plátky citronu vložte do koše. Přidejte snítky bylinek. Přidejte česnek. Pak na to vložte artyčok. Naplňte vodou po úroveň 2 na stupnici vlevo uvnitř mísy. Koš položte nahoru na mísu. Víko uzavřete. V menu zvolte ☰ a stiskněte ◊. Artyčoky jsou uvařené, jakmile je možné větší listy snadno oddělit. Podávejte teplé nebo studené s octovým dresinkem. Je to úžasné!

EINTOPF S KROUPAMI A FAZOLEMI BORLOTTI

DUŠENÍ Ⓢ

1 🍷	olivový olej	1 🍷	fazole borlotti
175 g	kroupy	1	cibule, nejmenno nakrájená
1 🍷	rajčata na kousky	1 🍷	rajský protlak
1000 ml	zeleninový bujón	2 🍷	petržel (nasekaná)
125 ml	suché červené víno		sůl a pepř

podávání:

pálivý chilli olej (volitelné)

Otevřete víko. V menu zvolte ☰ a stiskněte ◊. Přidejte vývar. Přiveďte k varu za stálého míchání. Zvolna vařte 10 minut. Vývar přelijte do nějakého džbánu. Přidejte olej. Přidejte cibuli a lehce osmažte. Nalijte víno a vařte několik minut. Přidejte kroupy a míchejte, dokud nezačnou získávat barvu vína. Slijte fazole a přidejte je. Přidejte rajčata. Přidejte vývar. Dvakrát stiskněte Ⓢ, čímž se program zastaví. Víko uzavřete. Zvolte Ⓢ. 30 minut před ukončením nastaveného času vaření poklici otevřete. Zkontrolujte množství tekutiny v míse. Přidejte 150 ml horké vody, pokud je to nutné. Víko uzavřete. Počkejte, až program doběhne. Podávejte s čerstvým křupavým chlebem a postříkejte pálivým chilli olejem.

PIŠKOTOVÝ DEZERT SE SIRUPEM

PÁRA ☰

115 g	máslo	2	☰
100 g	moučkový cukr	¼ 🍷	esence vanilky
175 g	samokynoucí mouka	2 🍷	mléko
4 🍷	zlatý sirup		

V další míse rozšlehejte vejce. V míse zpěňte máslo s cukrem. Postupně přidávejte vejce, pak vanilku a potom mouku. Vmíchejte mléko. Vymažte 1200 ml zapékačskou mísu. Sirup nalijte na dno této zapékačské mísy a na to nalijte směs. Přikryjte pečícím papírem a potom alobalem, nahoře obvažte provázekem. Otevřete víko. Tuto zapékačskou mísu vložte do mísy v přístroji. Do mísy v přístroji nalijte dostatek vroucí vody, aby sahala 3 cm pod horní okraj zapékačské mísy. Víko uzavřete. V menu zvolte ☰. Čas pečení nastavte na 1 hodinu a 30 minut. Stiskněte ◊ tlačítko. Počkejte, až program doběhne. Překlopte na talíř a podávejte teplé. Je to skvělý dezert pro každou příležitost!!



PORRIDGE (OVESNÁ KAŠE)

KAŠE/RIZOTO

2 	ovesná mouka		voda
1 1/4 	sůl	2 	cukr

podávání:

tmavě hnědý cukr mléko / 18% smetana

Otevřete víko. Nasypte ovesné vločky, sůl a cukr. Nalijte vodu po úroveň 1 1/2 na stupnici vpravo uvnitř mísy. Víko uzavřete. V menu zvolte  a stiskněte . Počkejte, až program doběhne. Podávejte s mlékem nebo smetanou. Posypte tmavě hnědým cukrem. Pokud chcete, 15 minut před ukončením nastaveného času vaření můžete do kaše dát i na kostičky nakrájené sušené meruňky či napůl rozkrojené sušené švestky (bez pecek). Zbylou kaši je možné uložit až na 2 dny do lednice, a potom znovu ohřát.



NUTTY PORRIDGE (KAŠE S MANDLEMI)

KAŠE/RIZOTO

1/2 	ovesné vločky		voda
120 ml	mléko	3 	strouhaný kokos
1 	mletá skořice		

podávání:

zlatý sirup drčené mandle

Otevřete víko. Nasypte ovesné vločky, skořici, kokos a mléko. Nalijte vodu po úroveň 1/2 na stupnici vpravo uvnitř mísy. Víko uzavřete. V menu zvolte  a stiskněte . Počkejte, až program doběhne. Nahoře pokapejte zlatým sirupem a posypte drčenými mandlemi.





RIZOTO Z ČERVENÉ ŘEPY V MULTICOOKERU

KAŠE/RIZOTO

400 g	červená řepa	2 	olivový olej
250 g	rýže arborio/rýže na rizoto	1	cibule, najemno nakrájená
250 ml	bílé víno	2 	česnek, oloupaný a nakrájený
900 ml	zeleninový bujón / kuřecí vývar	1 	tymián, najemno nasekaný





na závěr:

100 ml	jogurt	1 	petržel (nasekaná)
1 	máslo		

Otevřete víko. V menu zvolte  a stiskněte . Přidejte vývar. Přiveďte k varu za stálého míchání. Zvolna vařte 10 minut. Vývar přelijte do nějakého džbánu. Dvakrát stiskněte , čímž se program zastaví. V menu zvolte  a stiskněte . Nechte přístroj zahřát. Červenou řepu oloupejte a nakrájejte na 1 cm kostky. Do mísy dejte červenou řepu, česnek a cibuli. Cibuli vařte do změknutí. Vmíchejte rýži. Přiklopte poklici a vařte 3-4 minuty. Otevřete víko. Vmíchejte víno. Přiklopte poklici a vařte 3-4 minuty. Otevřete víko. Přidejte tymián. Přidejte vývar. Víko uzavřete. Počkejte, až program doběhne. Zkontrolujte rýži – měla by být al dente, avšak ne tvrdá. Pokud ještě není hotová, přidejte trochu vody a vařte ještě několik minut. Vmíchejte máslo – dodá to rizotu lesk. Podávejte s trochou jogurtu a posypte petrželí. Je to skvělé jako předkrm nebo lehký oběd.

LAHODNÁ RÝŽE



RÝŽE



2 	rýže		voda
1	bujón (zeleninový)	2	mrkev, na kostičky
1	červená paprika, zbavená semen a nakrájená	2 	celer, nakrájený
1 	kurkuma	1 	hrášek (volitelné)





Otevřete víko. Rýži nasypte do mísy. Naplňte vodou po úroveň 2 na stupnici vlevo uvnitř mísy. Rozdrťte kostku vývaru a vmíchejte do vody. Přidejte zbývající ingredience. Víko uzavřete. Zvolte . Počkejte, až program doběhne, a potom podávejte. Pokud rýže ještě není zcela hotová, nechte ji ještě několik minut vařit v páře s přiklopenou poklicí.

RAJČATOVÁ HUTNÁ POLÉVKA



POLÉVKA 





- 1 cibule, na kostičky
- 1  rajčata na kousky
- 1 červená paprika, zbavená semen a nakrájená
- 550 ml kuřecí vývar
- 1  sušená směs bylin



- 1  olivový olej
- 2 rajčata na kousky
- 2 brambory
- 1  rajský protlak
- 1  černý pepř

Otevřete víko. Přidejte vývar. V menu zvolte  a stiskněte . Přiveďte k varu za stálého míchání. Zvolna vařte 10 minut. Vývar přelijte do nějakého džbánu. Dvakrát stiskněte , čímž se program zastaví. Rajčata oloupejte a nakrájejte na kostky. V menu zvolte  a stiskněte . Přidejte olej. Přidejte cibuli a sladkou papriku. Cibuli vařte do změknutí. Přidejte vývar. Přidejte zbývající ingredience. Víko uzavřete. Počkejte, až program doběhne. Dochutě kořením. Podávejte s křupavým chlebem.

KUŘE S RAJČATY A HOUBAMI MASO



- 2 kuřecí prsa bez kůže a vykostěná
- 450 g hnědění žampiony, nakrájené na kostičky
- 2  česnek, oloupaný a nakrájený
- 1  Worcesterová omáčka
- sůl a pepř



- 1  olivový olej
- 1  rajčata na kousky
- 1  rajčatová omáčka
- 1  sušené oregáno





Otevřete víko. V menu zvolte  a stiskněte . Přidejte olej. Kuřecí prsa osolte a opepřete a dejte je do mísy. Maso otočte, aby se udělalo z obou stran. Přidejte česnek a houby. Pečte 3-4 minuty s tím, že kuře jednou otočíte. Přidejte rajčata, worchestrovou omáčku, rajčatovou omáčku a oregano. Pečte dál, kuře pak ještě jednou otočte. Podívejte se, zda je kuře dobře propečené. Podávejte s těstovinami, bramborami nebo rýží. Je to rychlé a chutné jídlo z běžných surovin.

JABLEČNÁ POLÉVKA S CHORIZEM A KAPUSTOU

POLÉVKA 

- ¼ chorizo, nejmenno nakrájené
- 1 jablko
- 2  celer, nakrájený
- ¼ kapusta, nejmenno nakrájená
- 2  česnek, oloupaný a nakrájený
- 1  sůl
- 850 ml zeleninový bujón



- 1 cibule, nejmenno nakrájená
- 2 mrkev, na kostičky
- 2 rajčata na kousky
- 1  rajský protlak
- 1  kajenský pepř
- 1  černý pepř



Otevřete víko. V menu zvolte  a stiskněte . Na prudko osmažte chorizo, asi 2 minuty. Přidejte cibuli a česnek. Cibuli vařte do změknutí. Jablko zbavte slupky a jádřince a nakrájejte. Přidejte zbývající ingredience. Dvakrát stiskněte , čímž se program zastaví. Víko uzavřete. V menu zvolte  a stiskněte . Počkejte, až program doběhne. Polévka je opravdu výborná, a jestli ji necháte přes noc v lednici, chuť se ještě lépe rozvine.

DUŠENÁ ŽEBRA NA PIVĚ S JAVOROVÝM SIRUPEM A SÓJOVOU OMÁČKOU



MASO 

- 1 kg vepřová žebra
- 350 ml Guinness / černé pivo
- 140 ml hovězí vývar / vepřový vývar
- 60 ml javorový sirup / med





- 1 cibule, na kostičky
- 1  olivový olej
- 3  česnek, oloupaný a nakrájený
- 2  tmavá sójová omáčka





Otevřete víko. V menu zvolte . Přidejte olej. Čas pečení nastavte na 1 hodinu a 45 minut. Stiskněte  tlačítko. Vložte žebra a nechte péct 5 minut dozlatova – občas otočte. Žebra vyndejte. Přidejte cibuli a česnek. Cibuli vařte do změknutí. Žebra vložte zpět do mísy. Vmíchejte Guinness, vývar, javorový sirup a sójovou omáčku. Víko uzavřete. Počkejte, až program doběhne. Dochutě kořením a podávejte. Je to výborný předkrm nebo jako součást pestrého oběda.

EINTOPF Z HOVĚZÍCH ŽEBER

1 kg	hovězí žebra
2 	česnek, oloupaný a nakrájený
50 g	chorizo, na plátky
2	červená cibule, na kostičky
600 ml	hovězí vývar
2 	sušená směs bylin
6-8	brambory (malé)
2 	Worcesterová omáčka

POMALÉ VAŘENÍ

2 	rajský protlak
2 	bobkový list
2	mrkev
3 	celer
2 	rozmarýn, nasekaný
1 	rajčata na kousky sůl a pepř

Brambory neloupejte. Brambory, mrkev a celer nakrájejte na větší kousky. Hovězí žebra osolte a opepřete. Otevřete víko. V menu zvolte  a stiskněte . Přidejte vývar. Přiveďte k varu za stálého míchání. Zvolna vařte 10 minut. Vývar přelijte do nějakého džbánu. Na prudko osmažte chorizo, asi 2 minuty. Přidejte maso. Opečte dozlatova. Přidejte cibuli, česnek, brambory, celer a mrkev. Pokud máte ještě nějakou další kořenovou zeleninu, kterou chcete spotřebovat, přidejte ji také. Cibuli vařte do změknutí. Přidejte vývar. Přidejte zbývající ingredience. Dvakrát stiskněte , čímž se program zastaví. Zvolte . Počkejte, až program doběhne, a potom podávejte. Vůbec nebude na škodu, když necháte vařit 8 hodin, ale jídlo bude pravděpodobně připravené již po 5 hodinách.

Prečítajte si pokyny a odložte tak, aby ste ich mohli priložiť pri prípadnom odovzdaní výrobku niekomu inému. Pred použitím odstráňte všetky obaly.

DÔLEŽITÉ BEZPEČNOSTNÉ OPATRENIA

Dodržujte základné bezpečnostné opatrenia, vrátane:

Tento prístroj môžu používať deti od 8 rokov a osoby so zníženými fyzickými, zmyslovými alebo psychickými schopnosťami alebo nedostatkom skúseností a vedomostí ak sú pod dozorom/poučení a sú si vedomí s tým spojených rizík. Deti sa s prístrojom nemajú hrať. Čistenie a používateľská údržba nemajú byť vykonávané deťmi ak nie sú staršie ako 8 rokov a pod dozorom. Prístroj a elektrickú šnúru uchovávajte mimo dosahu detí mladších ako 8 rokov.

Ak je konektor alebo kábel poškodený, musia byť vymenené za špeciálnu zostavu od výrobcu alebo jeho servisného zástupcu.

 Nepoužívajte tento prístroj v blízkosti vane, sprchy, umývadla alebo iných nádob s vodou.

 Nesprávne používanie spotrebiča môže viesť k poraneniu.

 Povrchy spotrebiča budú horúce. Zvyškové teplo bude po použití udržiavať povrchy teplé.

- Nedávajte do spotrebiča mrazené mäso alebo hydinu – pred použitím ich úplne rozmrazte.
- Mäso, hydinu a jedlá z nich (mleté mäso, hamburgery, atď.) grilujte, až kým z nich nevyteká čistá šťava. Rybu grilujte dovtedy, kým nie je mäso vo všetkých častiach nepriehľadné.
- Nepokúšajte sa čokoľvek variť v tele hrnca – varte iba v odnímateľnej nádobe.
- Nenapíňajte nad max.
- Spotrebič neprikrývajte ani nedávajte žiadne predmety na jeho vrchnú časť.
- Vyberte zástrčku z elektrickej zásuvky a potom vyberte konektor z otvoru na prístroji.
- Keď prístroj nepoužívate, odpojte ho z elektrickej siete.
- Nepoužívajte iné doplnky alebo vybavenie ako tie, ktoré boli dodané.
- Nepoužívajte spotrebič na iné účely ako tie, ktoré sú popísané v týchto pokynoch.
- Nepoužívajte tento spotrebič, ak je poškodený alebo má poruchu.

LEN NA DOMÁCE POUŽITIE

NÁKRESY

- | | |
|---------------------------------|-------------|
| 1. Panel sterovania | 5. Odmerka |
| 2. Vrchnák | 6. Košík |
| 3. Tlačidlo na uvoľnenie viečka | 7. Nádoba |
| 4. Vnútorň vrchnák | 8. Konektor |



PRÍPRAVA

1. Spotrebič postavte na stabilný, vodorovný a teplu odolný povrch.
2. Nepoužívajte spotrebič v blízkosti alebo pod záclonami, poličkami, skrinkami alebo čímkoliek, čo sa dá ľahko poškodiť unikajúcou parou.
3. Majte poruke kuchynské chňapky (alebo utierku) a tepelne odolnú podložku alebo plytký tanier, na ktoré položíte nádobu po varení.





4. Nádobu vložte do parného hrnca.
5. Otočte nádobou o štvrt otočky v každom smere, aby ste zabezpečili dobrý kontakt dna nádoby s ohrievacím telesom.



RYŽA

1. Na pridanie ryže do nádoby použite odmerku.
2. Nepoužívajte viac ako 10 odmeriek ryže.
3. Použite stupnicu vľavo vo vnútri nádoby, ktorá je označená od 2 do 10.
4. Naplňte nádobu vodou až po číslo, ktoré sa zhoduje s počtom odmeriek pridanej ryže.
5. Zatvorte veko.
6. Stlačte tlačidlo . Tlačidlo bude svietiť.
7. Vonkajšie časti displeja budú počas zohrievania jedla blikať.
8. Displej potom ukáže zostávajúci čas varenia (13 minút), a bude odpočítavať.
9. Na konci času varenia sa prístroj prepne do režimu „udržiavať teplé“. Zsvietí svetielko .
10. Otvorte veko.
11. Nádobu vyberte a položte ju na tepelne odolnú podložku alebo plytký tanier.
12. Stlačte tlačidlo .
13. Vareškou prevráťte a zamiešajte ryžu, aby ste uvoľnili všetku paru.
14. Niekedy sa na vrstve ryže, ktorá je v kontakte so stenami nádoby vytvorí kôra.
15. Ak ju nechcete, môžete ju po naservírovaní ryže odstrániť vareškou.

POMALÉ VARENIE





1. Rýchlo opečte mäso a zeleninu (pozri „OPIECŤ/OPRAŽIŤ/ZMÄKNÚŤ/VARIŤ“).
2. Prevarte vývar (pozri „OPIECŤ/OPRAŽIŤ/ZMÄKNÚŤ/VARIŤ“).
3. Do nádoby vložte pevné prísady, potom pridajte vývar.
4. Zatvorte veko.
5. Stlačte tlačidlo . Tlačidlo bude svietiť.
6. Displej bude zobrazovať 8 hodín, a bude odpočítavať čas.
7. Na konci času varenia prejde prístroj do režimu „udržiavať teplé“. Zsvietí svetielko .
8. Stlačte tlačidlo . Otvorte veko. Jedlo vyberte.

DUSENIE

1. Rýchlo opečte mäso a zeleninu (pozri „OPIECŤ/OPRAŽIŤ/ZMÄKNÚŤ/VARIŤ“).
2. Prevarte vývar (pozri „OPIECŤ/OPRAŽIŤ/ZMÄKNÚŤ/VARIŤ“).
3. Do nádoby vložte pevné prísady, potom pridajte vývar.
4. Zatvorte veko.
5. Stlačte tlačidlo . Tlačidlo bude svietiť.
6. Displej bude zobrazovať 1 hodinu, a bude odpočítavať čas.
7. Na konci času varenia sa prístroj prepne do režimu „udržiavať teplé“. Zsvietí svetielko .
8. Stlačte tlačidlo . Otvorte veko. Jedlo vyberte.

MÄSO

1. Jedlo potrite z každej strany olejom na varenie.
2. Povrch jedla potrite korením a prísadami.
3. Do nádoby pridajte polievkovú lyžicu oleja na varenie.
4. Vložte do nádoby jedlo.
5. Zatvorte veko.
6. Čas závisí od veľkosti jedla.
7. Nepripravujte viac ako 500 g jedla naraz.
8. Odporúčame čas prípravy 10 min + 10 minút na každých 100 g hmotnosti hovädzieho mäsa.
9. Bravčové alebo hydinu nevarajte menej ako 5, 10, 15, 20, 25, 30 minút.

10. Vyberte  v menu pomocou tlačidla .
11. Vyberte si čas varenia/prípravy. Prednastavený čas je 20 minút.
12. Tlačidlá h a min môžete používať len vtedy, keď bliká čas na displeji.
13. Pomocou tlačidla min posúvajte displej po možnostiach (10, 15, 20, 25, 5, 10, 15, 20, 25, 30, 35, 40, 45, 50 a 55).
14. Ak chcete variť 1 hodinu, stlačte tlačidlo h.
15. Ak chcete zrušiť nastavenie 1 hodiny, stlačte znovu tlačidlo h, pričom čas na displeji bliká.
 - Ak 2 minúty nič nespravíte, prístroj sa vráti do pohotovostného režimu.
16. Po nastavení času stlačte .
17. Displej bude odpočítavať.
18. Na konci času varenia sa prístroj prepne do režimu „udržiavať teplé“. Zasvieti svetielko .
19. Stlačte tlačidlo . Otvorte veko. Jedlo vyberte.

POLIEVKA

1. Rýchlo opečte mäso a zeleninu (pozri „OPIECŤ/OPRAŽIŤ/ZMÄKNÚŤ/VARIŤ“).
2. Do nádoby vložte pevné prísady, potom pridajte vývar.
3. Zatvorte veko.
4. Vyberte X v menu pomocou tlačidla].
5. Vyberte si čas varenia/prípravy. Prednastavený čas je 1 hodina.
6. Tlačidlá h a min môžete používať len vtedy, keď bliká čas na displeji.
7. Pomocou tlačidla min posúvajte displej po možnostiach (10, 15, 20, 25, 5, 10, 15, 20, 25, 30, 35, 40, 45, 50 a 55).
8. Pomocou tlačidla h posúvajte displej po možnostiach (1, 2, 3, 4 a 5).
9. Ak chcete zrušiť nastavenie 5 hodiny, stlačte znovu tlačidlo h, pričom čas na displeji bliká.
 - Ak 2 minúty nič nespravíte, prístroj sa vráti do pohotovostného režimu.
10. S týmto programom máte možnosť použiť časovač (pozri ČASOVAČ).
11. Stlačte tlačidlo v.
12. Displej bude odpočítavať.
13. Na konci času varenia sa prístroj prepne do režimu „udržiavať teplé“. Zasvieti svetielko W.
14. Stlačte tlačidlo w. Otvorte veko. Jedlo vyberte.



JOGURT

Jogurtová kultúra

Môžete použiť 5, 10, 15, 20, 25, 30 ml (2 polievkové lyžice):

- Neochuteného živého jogurtu – musí byť čerstvý (hľadajte jogurt s dlhou dobou spotreby). Výsledok bude závisieť od značky.

Jogurtu, ktorý ste urobili predtým.





- Baktérie sa časom oslabujú, takže to môžete urobiť iba 10 krát, a potom treba použiť novú kultúru. Sušený jogurtovej kultúry z lekárne alebo obchodu so zdravými potravinami.
- Ak sa návod na prípravu na obale kultúry líši od tohto návodu, postupujte podľa návodu na obale.

Mlieko





- Budete potrebovať 1 liter mlieka.
- Z plnotučného mlieka vyrobíte hustejší jogurt ako z nízkotučného.
- Na dosiahnutie ešte hustejšieho jogurtu môžete pridať do tekutého mlieka až 8 polievkových lyžíc sušeného mlieka.
- Môžete tiež použiť rozriedené sušené mlieko, alebo zahustené mlieko z konzervy.

Výroba jogurtu



1. Potrebujete zabiť baktérie v mlieku, aby ste zabránili ich konkurovaniu baktériám v jogurtovej kultúre.
2. Počas zahrievania mlieka nechajte jogurtovú kultúru dosiahnuť izbovú teplotu.
3. Otvorte veko.
4. Použite program VARENIE V PARE (OPIECŤ/OPRAŽIŤ/ZMÄKNÚŤ/VARIŤ) na zohriatie mlieka pod bod varu.

5. Nechajte mlieko zohriať, až kým sa na okrajoch netvorí bubliny.
6. Nechajte mlieko vychladnúť na 37°C až 45°C.
7. Vmiešajte do mlieka jogurtovú kultúru.
8. Musia byť riadne zamiešané, inak bude jogurt hrudkovitý.
9. Zatvorte veko.
10. Vyberte  v menu pomocou tlačidla .
11. Vyberte si čas varenia/prípravy. Prednastavený čas je 8 hodín.
12. Tlačidlá h a min môžete používať len vtedy, keď bliká čas na displeji.
13. Pomocou tlačidla min posúvajte displej po možnostiach (10, 15, 20, 25, 5, 10, 15, 20, 25, 30, 35, 40, 45, 50 a 55).
14. Pomocou tlačidla h posúvajte displej po možnostiach (6, 7, 8, 9 a 10).
15. Ak chcete zrušiť nastavenie 10 hodiny, stlačte znovu tlačidlo h, pričom čas na displeji bliká.
 - Ak 2 minúty nič nespravíte, prístroj sa vráti do pohotovostného režimu.
16. S týmto programom máte možnosť použiť časovač (pozri ČASOVAČ).
17. Stlačte tlačidlo .
18. Displej bude odpočítavať.
19. Na konci času varenia sa prístroj prepne do pohotovostného režimu.
20. Nebude udržiavať jogurt teplý.
21. Stlačte tlačidlo . Otvorte veko. Jedlo vyberte.

CHLIEB

1. Pred použitím zmrazené cesto úplne rozmrazte.
2. Nepripravujte viac ako 500 g jedla naraz.
3. Nádoby vytrite olejom na varenie.
4. Vložte cesto do nádoby.
5. Zatvorte veko.
6. Pomocou tlačidla  vyberte v menu .
7. Vyberte si čas varenia/prípravy. Prednastavený čas je 3 hodín.
8. Tlačidlá h a min môžete používať len vtedy, keď bliká čas na displeji.
9. Pomocou tlačidla min posúvajte displej po možnostiach (10, 15, 20, 25, 5, 10, 15, 20, 25, 30, 35, 40, 45, 50 a 55).
10. Pomocou tlačidla h posúvajte displej po možnostiach (1, 2, 3, 4, 5 a 6).
11. Ak chcete zrušiť nastavenie 6 hodiny, stlačte znovu tlačidlo h, pričom čas na displeji bliká.
 - Ak 2 minúty nič nespravíte, prístroj sa vráti do pohotovostného režimu.
12. S týmto programom máte možnosť použiť časovač (pozri ČASOVAČ).
13. Stlačte tlačidlo .
14. Displej bude odpočítavať.
15. Na konci času varenia sa prístroj prepne do režimu „udržiavať teplé“. Zsvieti svetielko .
16. Stlačte tlačidlo . Otvorte veko. Jedlo vyberte.

RYBY

1. Jedlo potrite z každej strany olejom na varenie.
2. Povrch jedla potrite korením a prísadami.
3. Do nádoby pridajte polievkovú lyžicu oleja na varenie.
4. Vložte do nádoby jedlo.
5. Zatvorte veko.
6. Čas závisí od veľkosti jedla.
7. Nepripravujte viac ako 500 g jedla naraz.
8. Navrhujeme čas varenia 10 minút na 100 g hmotnosti.
9. Vyberte  v menu pomocou tlačidla .
10. Vyberte si čas varenia/prípravy. Prednastavený čas je 20 minút.
11. Tlačidlá h a min môžete používať len vtedy, keď bliká čas na displeji.

12. Pomocou tlačidla min posúvajte displej po možnostiach (10, 15, 20, 25, 5, 10, 15, 20, 25, 30, 35, 40, 45, 50 a 55).
13. Ak chcete variť 1 hodinu, stlačte tlačidlo h.
14. Ak chcete zrušiť nastavenie 1 hodiny, stlačte znovu tlačidlo h, pričom čas na displeji bliká.
 - Ak 2 minúty nič nespravíte, prístroj sa vráti do pohotovostného režimu.
15. Po nastavení času stlačte ◊.
16. Displej bude odpočítavať.
17. Na konci času varenia sa prístroj prepne do režimu „udržiavať teplé“. Zasvieti svetielko ☹.
18. Najlepšie je vybrať jedlo hneď, ako sa uvarilo, aby sa zabránilo jeho vysušeniu.
19. Stlačte tlačidlo ⚙. Otvorte veko. Jedlo vyberte.

VARENIE V PARE

1. Naplňte nádobu studenou vodou až po značku 6.
2. Košík vložte do vrchnej časti nádoby a vložte do neho jedlo.
3. Kvôli rovnomernému vareniu pokrájajte všetky kúsky potravy na približne rovnakú veľkosť.
4. Na hrášok, alebo čokoliek, čo sa rozpadne alebo popadá do vody, použite balíček z alobalu.
5. Pri vyberaní balíčka si dávajte pozor – použite kuchynské chňapky a plastové kliešte/lyžice.
6. Zatvorte veko.
7. Vyberte  v menu pomocou tlačidla ⚙.
8. Vyberte si čas varenia/prípravy. Prednastavený čas je 30 minút.
 - Tieto by sa mali uvariť v rámci prednastaveného času:

Potravina (čerstvá)	Množstvo
Zelená fazuľka	200g
Ružičkový kel	200g
Mrkva (plátky)	200g
Zemiaky (štvrtky)	400g
Brokolica	200g
Kapusta	Štvrtka
Kukuricné	2

9. Tlačidlá h a min môžete používať len vtedy, keď bliká čas na displeji.
10. Pomocou tlačidla min posúvajte displej po možnostiach (5, 10, 15, 20, 25, 30, 35, 40, 45, 50 a 55).
11. Pomocou tlačidla h posúvajte displej po možnostiach (1 a 2).
12. Ak chcete zrušiť nastavenie 2 hodiny, stlačte znovu tlačidlo h, pričom čas na displeji bliká.
 - Ak 2 minúty nič nespravíte, prístroj sa vráti do pohotovostného režimu.
13. S týmto programom máte možnosť použiť časovač (pozri ČASOVAČ).
14. Stlačte tlačidlo v.
15. Displej bude odpočítavať.
16. Na konci času varenia sa prístroj prepne do režimu „udržiavať teplé“. Zasvieti svetielko W.
17. Najlepšie je vybrať jedlo hneď po uvarení, aby sa zabránilo jeho nasiaknutiu.
18. Stlačte tlačidlo w. Otvorte veko. Jedlo vyberte.

OPIEČŤ/OPRAŽIŤ/ZMÄKNÚŤ/VARIŤ

- Pred varením v inom programe môžete použiť program VARENIE V PARE  pri jeho prednastavenom nastavení, s otvoreným vrchnákom, ako pekáč s vysokou teplotou, po dobu 5, 10, 15, 20, 25, 30 minút.
- Použite ho s trochou oleja, aby ste opiekli mäso a zeleninu, na poprazenie, na zmäknutie cibule, zeleru, póru atď.

- Používajte ho s vodou alebo bujónom na predhriatie vývaru.
- Keď prepnete na hlavný program, prístroj je zohriaty, a niektoré alebo všetky vaše prísady už budú v nádobe.
- Nemusíte potom umývať pekáč, ktorý ste použili pri príprave.





OVSENÁ KAŠA/RIZOTO

Pomocou odmerky pridajte do nádoby obilniny (ryžu, ovsené vločky, raž atď.).

Ovsená kaša

- Použite stupnicu vpravo vo vnútri nádoby, ktorá je označená od ½ to 1½.
- Nenapĺňajte nad **max**.





Ryžová kaša

- Použite stupnicu v strede vo vnútri nádoby, ktorá je označená od 1 do 3.
 - Nenapĺňajte nad **max**.
1. Naplňte nádobu vodou po číslo, ktoré je vhodné s počtom odmeriek obilnín.
 2. Zatvorte veko.
 3. Vyberte  v menu pomocou tlačidla .
 4. Vyberte si čas varenia/prípravy. Prednastavený čas je 1 hodina.
 5. Tlačidlá h a min môžete používať len vtedy, keď bliká čas na displeji.
 6. Pomocou tlačidla min posúvajte displej po možnostiach (5, 10, 15, 20, 25, 30, 35, 40, 45, 50 a 55).
 7. Pomocou tlačidla h posúvajte displej po možnostiach (1, 2, 3 a 4).
 8. Ak chcete zrušiť nastavenie 4 hodiny, stlačte znovu tlačidlo h, pričom čas na displeji bliká.
 - Ak 2 minúty nič nespravíte, prístroj sa vráti do pohotovostného režimu.
 9. S týmto programom máte možnosť použiť časovač (pozri ČASOVAČ).
 10. Stlačte tlačidlo .
 11. Displej bude odpočítavať.
 12. Na konci času varenia sa prístroj prepne do režimu „udržiavať teplé“. Zsvietí svetielko .
 13. Stlačte tlačidlo . Otvorte veko. Jedlo vyberte.



Rizoto

Postupujte podľa receptu, ktorý je uvedený ďalej v tejto brožúrke.









KOLÁČ

1. Pred použitím zmrazené cesto úplne rozmrazte.
2. Nenapĺňajte nádobu viac, ako do polovice.
3. Nádobu vytrite olejom na varenie.
4. Vložte cesto do nádoby.
5. Zatvorte veko.
6. Vyberte  v menu pomocou tlačidla .
7. Vyberte si čas varenia/prípravy. Prednastavený čas je 40 minút.
8. Prednastavený čas je 40 minút.
9. Tlačidlá h a min môžete používať len vtedy, keď bliká čas na displeji.
10. Pomocou tlačidla min posúvajte displej po možnostiach (5, 10, 15, 20, 25, 30, 35, 40, 45, 50 a 55).
11. Pomocou tlačidla h posúvajte displej po možnostiach (1 a 2).
12. Ak chcete zrušiť nastavenie 2 hodiny, stlačte znovu tlačidlo h, pričom čas na displeji bliká.
- Ak 2 minúty nič nespravíte, prístroj sa vráti do pohotovostného režimu.
13. Po nastavení času stlačte .
14. Displej bude odpočítavať.
15. Na konci času varenia sa prístroj prepne do režimu „udržiavať teplé“. Zsvietí svetielko .
16. Najlepšie je vybrať jedlo hneď po uvarení, aby sa zabránilo jeho nasiaknutiu.
17. Stlačte tlačidlo . Otvorte veko. Jedlo vyberte.

UDRŽIAVANIE V TEPLÉ

- Ak chcete použiť funkciu udržiavať teplé po programe, ktorý ju nepodporuje, potom, keď zostane na displeji len blikajúca svetelná kontrolka , stlačte .
- Na zrušenie tejto funkcie stlačte .

ČASOVAČ

- Pri programoch polievka , jogurt , chlieb , para  a ovsená kaša  môžete využiť odloženie časovača.
- Urobte tak hneď po nastavení času varenia a pred stlačením tlačidla zapnúť :
 1. Stlačte tlačidlo . Zsvietí svetielko .
 2. Rozhodnite sa, kedy chcete mať jedlo hotové.
 3. Napríklad, ak je teraz 14:00, a chcete, aby bolo hotové o 21:00, musíte nastaviť čas na 7 hodín.
 4. Pomocou tlačidiel **h** a **min** nastavíte správnu hodinu a minútu.
 5. Stlačte tlačidlo .

STAROSTLIVOSŤ A ÚDRŽBA

1. Spotrebič vyťahnite zo zásuvky a nechajte vychladnúť.
2. Zástrčku vyberte zo zásuvky, potom vyberte konektor z otvoru na prístroji.
3. Keď je vrchnák zatvorený, chyťte vrchnú časť filtra a vypáčte ho z vrchnáka (OBR. A).
4. Otočte ho naopak, aby ste obnažili značky na prednej strane.
5. Vrchnák filtra pevne držte a otočte zvyšok filtra smerom k otvorenej zámke  (OBR. B)
6. Stlačte ušká v spodnej časti vnútorného vrchnáka, a vyťahnite ho z prístroja (OBR. C)
7. Odnímateľné časti umývajte ručne.
8. Všetky povrchy utrite čistou vlhkou utierkou.
9. Nevkladajte žiadne časti spotrebiča do umývačky riadu.
10. Filter poskladajte naspäť a vráťte ho do vrchnáka.
11. Vnútrotný vrchnák založte späť do vrchnáka.







RECYKLÁCIA



Abyste nedochádzalo k ohrozeniu zdravia a životného prostredia vplyvom nebezpečných látok, prístroje a nabíjacie a nenabíjacie batérie označené niektorým z týchto symbolov nesmú byť likvidované s netriedeným komunálnym odpadom. Elektrické a elektronické výrobky a prípadne nabíjacie a nenabíjacie batérie vždy odovzdajte na príslušnom oficiálnom mieste pre recykláciu / zber.









RECEPTY









-  polievková lyžica (15ml)
-  čajová lyžička (5ml)
- g** gramov
- ml** mililitrov
-  odmerka
-  stonka/tyčka (zeler)
-  za hrst'
-  vajce, stredné (53-63 g)

-  štipka
-  trs, strapec
-  vetvička
-  strúčik (ov)
-  plechovka
-  pohár
-  vrecúško (7g)
-  vajce, veľké (63-73)

ZELENINOVO-KUSKUSOVÉ ČILI

POMALÉ VARENIE





2 	cesnak, ošúpaný a pokrájaný
1	červená paprika, bez semien a pokrájaná
1 	jalapenos (zelené stredne veľké čili papriky)
1	žltú papriku, bez semien a pokrájaná
1	oranžová paprika, bez semien a pokrájaná
1 	krájaných paradajok
1 	mletý koriander
1 	paradajkové pyré
850 ml	zeleninový bujón
2 	ostrá paradajková omáčka
120-140 ml	kuskus

1 	cannellini (veľká biela fazuľa)
1	veľká cibuľa, nakrájaná
1	červená cibuľa, nakrájaná
1 	fazole
1 	olivový olej
1 	veľká biela fazuľa
2 	mletá rasca
1 	cukor
2 	práškového čili
2 	sušeného oregana

porcií:



strúhaný syr
malý trs koriandra, pokrájaný





kyslá smotana



Otvorte veko. Pridajte olej. Zvoľte na menu  a stlačte . Pridajte cibuľu a cesnak. Varte, pokým cibuľa nezmäkne. Fazuľu precedte a pridajte. Kuskus si odložte. Pridajte zostávajúce prísady. Na zastavenie programu stlačte  dvakrát. Zatvorte veko. Zvoľte . Pridajte kuskus 30 minút pred skončením varenia. Ak je varenie už ukončené, zvoľte na menu  a varte ďalších 20 minút. Podávajte v nádobe s hrstou syra, pokropené kyslou smotanou a poprásené čerstvým koriandrom. Pri klasickom vegetariánskom čili vynechajte kuskus.

MAROCKÁ RYBACIA TAGINE (POMALY DUSENÉ JEDLO)

RYBA

2 	cesnak, ošúpaný a pokrájaný
1	červená paprika, bez semien a pokrájaná
2	krájaných paradajok
1 	mletý zázvor
1 	pasta z harissy – štiplavej čili papričky
120 ml	biele víno
120 ml	rybací vývar
675 g	ryba (treska /lososa
1	malý trs koriandra, pokrájaný

1	cibuľa, pokrájaná
2 	stopkový zeler, pokrájaný
1 	mletá rasca
1 	kurkuma
1	škoricová tyčinka
1 	paradajkové pyré
1	citrón
1 	zelené olivy
	soľ a čierne korenie

Koriander si odložte. Otvorte veko. Pridajte zostávajúce prísady. Zatvorte veko. Zvoľte na menu  a stlačte . Varte, kým jedlo nezačne byť vložkovité (40 – 60 min). Na zastavenie programu stlačte  dvakrát. Pridajte koriander. Pridajte korenie a podávajte. Chutí výborne v kombinácii s kuskusom.

DOMÁCI JOGURT

JOGURT





1200 ml mlieko

100 ml jogurt









výber príchute

50 g mrazená zmes lesného ovocia





1  med





Otvorte veko. Pridajte mlieko. Zvoľte na menu  a stlačte . Nechajte mlieko zohriať, až kým sa na okrajoch netvorí bubliny. Na zastavenie programu stlačte  dvakrát. Nechajte mlieko vychladnúť na 37°C až 45°C. Zamiešajte do mlieka jogurt. Musia byť riadne zamiešané, inak bude jogurt hrudkovitý. Zatvorte veko. Zvoľte na menu  a stlačte . Počkajte, kým program skončí. Jogurt vložte do chladničky, aby úplne vychladol. Lesné ovocie jemne zohrejte v hrnci. Pridajte med. Keď sa bobule začínajú rozpadávať, siahnite ich z tepla, nechajte ich vychladnúť a potom zmiešajte s jogurtom. Ak chcete jogurt uskladniť, musíte sterilizovať poháre, ktoré použijete. Zohrejte ich v rúre na 100°C počas 10 minút. Jogurt vydrží v chladničke až 2 týždne.

OHNIVÉ HOVÄDZIE ČILI Z NY

450 g	prírodná hovädzia pečienka
3 	cesnak, ošúpaný a pokrájaný
2 	mletá rasca
1 	cayenské korenie
2 	paradajky
1 	bobkový list
1 	na hrubo nakrájané listy bazalky
1 	fazule
1 	údená mletá paprika/prášok zo sušeného zeleného čili



DUSENIE



1 	olivový olej
2	cibuľa, nakrájaná
2 	práškového čili
2 	paradajková omáčka
1	zelenej papriky
1 	soľ
1 	čierne korenie





Otvorte veko. Pridajte olej. Zvoľte na menu  a stlačte . Hovädzie, paradajky a papriku nakrájajte na malé kúsky na zjedenie. Mäso opečte, potom ho vyberte. Pridajte cibuľu, cesnak a všetky bylinky. Varte, pokým cibuľa nezmäkne. Pridajte mäso. Fazulu si odložte. Pridajte zostávajúce prísady. Na zastavenie programu stlačte  dvakrát. Zatvorte veko. Zvoľte . Pridajte fazulu 30 minút pred ukončením varenia. Ak je mäso stále na konci programu trochu tvrdé, pridajte odmerku vody a spustíte program mäsa na ďalších 30 minút.

HRACHOVÁ POLIEVKA Z LÚPANÉHO HRACHU S BRAVČOVÝM KOLIENKOM



POMALÉ VARENIE



1150 ml	kuracieho vývaru
225 g	lúpaný hrach poľený
1 	stopkový zeler, pokrájaný
1 	tymián, nakrájaný na jemno
1	bravčové kolienko

1	cibuľa, nakrájaná na jemno
1	mrkva, nakrájaná
2 	cesnak (pretlačený)
1 	bobkový list
	čierne korenie

Otvorte veko. Pridajte bujón. Zvoľte na menu  a stlačte . Privedte do varu, za stáleho miešania. Varte na miernom ohni 10 minút. Pridajte zostávajúce prísady. Na zastavenie programu stlačte  dvakrát. Zatvorte veko. Zvoľte . Počkajte, kým program skončí. Bravčové kolienko vyberte. Kožu a kosti vyhodte. Mäso nakrájajte na kocky. Vyhodte bobkový list. Lúpaný hrach popučte zadnou časťou drevenej varešky. Pridajte mäso. Pridajte korenie a podávajte. Nebíčko v nádobe!



LOSOS NA PIKANTNÝ SPÔSOB

2	lososové filety (s kožou)
1 	paprika
½ 	mletá rasca
1 	mäkký hnedý cukor

1 	olivový olej
1 	práškového čili
1 	soľ a čierne korenie
1	citrón

RYBA





Zmiešajte červenú papriku, čili, rascu, cukor, soľ a čierne korenie. Pokropte lososové filety. Otvorte veko. Pridajte olej. Zvoľte na menu  a stlačte . Počkajte niekoľko minút, aby sa zohrial olej. Pridajte filety s kožou nadol. Zatvorte veko. Toto je výborná kombinácia varenia v pare a praženia kúskov ryby, a získate chrumkavú kožu. Podávajte s mesiačikom citróna. Vynikajúce ľahké jedlo.

ČOKOLÁDOVÝ KOLÁČ „BROWNIE“



170 g	nesolené maslo
340 g	cukor
170 g	kakaový prášok
110 g	kúsky mliečnej čokolády

KOLÁČ

3	
1 	vanilková esencia
1 	soľ
75 g	čistá múka

porcií:



vanilková zmrzlina (nemusi byť)





V panvici na miernom ohni rozpustíte maslo. Nádobu vyložte fóliou vymastenou maslom. V miske vyšľahajte zmäknuté maslo, cukor, kakaový prášok, múku, vajíčka, vanilku a soľ. Zapracujte do zmesi kúsky mliečnej čokolády. Cesto vložte do fólie v nádobe. Zatvorte veko. Zvoľte v menu . Nastavte čas prípravy na 1 hodinu 30 minút. Stlačte tlačidlo . Koláč by mal byť pevný okolo okrajov a trochu poddajný v strede. Koláč podávajte teplý, ozdobený zmrzlinou.

IRISH STEW S KNEDLÍKMI Z KOZIEHO SYRA

DUSENIE 





na stew:

1.8 kg	jahňacie plece (uvarené)
250 g	prerastanej slaniny
950 ml	jahňací vývar
1	veľká cibuľa, nakrájaná
2 	stopkový zeler, pokrájany
2 	paradajkové pyré





1 	olivový olej
3 	cesnak (pretlačený)
	soľ a čierne korenie
2	mrkva, nakrájaná
2 	rozmarín, nasekaný
1 	kukuricičná múka

na knedlíky:

100 g	múka s prísadou kypriaceho prášku
50 g	hovädzí loj
75 ml	voda
40 g	kozí syr (mäkký)
1 	sušený majorán

1 	prášok do pečiva
1 	soľ
1 	sušený petržlen
1 	sušeného tymiánu
1 	čierne korenie

na stew:

Mäso oddelíte od kosti. Nakrájajte mäso a slaninu na menšie kúsky. Otvorte veko. Zvoľte na menu  a stlačte . Pridajte bujón. Privedte do varu, za stáleho miešania. Varte na miernom ohni 10 minút. Vývar prelejte do krčaha. Pridajte olej. Pridajte cibuľu a opražte do mäkka. Pridajte mäso, cesnak, bylinky a inú zeleninu a varte 5 minút. Pridajte bujón. Pridajte paradajkové pyré. Na zastavenie programu stlačte  dvakrát. Zatvorte veko. Zvoľte .

na knedlíky:

Všetky prísady ručne premiešajte. Zmes rozdeľte do 6 guliek. Nechajte 20 minút odležať.

na dokončenie:



Pripravte v šálke hladkú pastu z kukuričnej múky a trochy vody. 30 minút pred ukončením varenia otvorte vrchnák. Zamiešajte pastu do stew. Pridajte knedlíky. Vrchník zatvorte. Počkajte, kým program skončí, potom podávajte. Senzačná nádoba pohodlného jedla!

- Ak nemáte žiadne varené jahňacie, môžete použiť surové jahňacie, a program pomalého varenia namiesto programu na dusenie, potom pokračujte od bodu s knedlíkmi.

ARTIČOKY VARENÉ V PARE



PARA 



1 	cesnak, ošúpaný a pokrájany	2	artičoky typu Globe
	vetvičky byliniek (estragón, mäta, petržlen, tym	ian)	1 citrón

Nakrájajte citrón na kolieska. Odkrojte stonku zarovno so spodnou časťou každého artičoku. Odkrojte vrchnú štvrtinu z každého artičoku. Zahodte všetky poškodené listy. Odrezané plochy potrite plátkom citróna. Plátky citróna poukladajte do košíka. Pridajte vetvičky byliniek. Pridajte cesnak. Artičok položte navrch. Naplňte vodou po úroveň 2 na stupnici vľavo vo vnútri nádoby. Košík položte na vrchnú časť nádoby. Zatvorte veko. Zvoľte na menu  a stlačte . Artičoky sú uvarené vtedy, keď sa dajú vonkajšie listy ľahko odtrhnúť. Podávajte teplé alebo studené so zálievkou. Neskutočné!

HRNIEC Z JAČMENNÝCH KRÚPOV A FAZULE BORLOTTI

DUSENIE 

1 	olivový olej
175 g	jačmenné krúpy
1 	krájaných paradajok
1000 ml	zeleninový bujón
125 ml	suché červené víno

1 	fazuľa borlotti
1	cibuľa, nakrájaná na jemno
1 	paradajkové pyré
2 	petržlen (nasekaný)
	soľ a čierne korenie

porcií:

olej s ostrým čili (nemusí byť)

Otvorte veko. Zvoľte na menu a stlačte . Pridajte bujón. Privedte do varu, za stáleho miešania. Varte na miernom ohni 10 minút. Vývar prelejte do krčaha. Pridajte olej. Pridajte cibuľu a opražte do mäčka. Pridajte víno a niekoľko minút varte. Pridajte jačmenné krúpy a miešajte, až kým nezačnú naberať farbu vína. Fazuľu scedte a pridajte. Pridajte paradajky. Pridajte bujón. Na zastavenie programu stlačte dvakrát. Zatvorte veko. Zvoľte , 30 minút pred ukončením varenia otvorte vrchnák. Skontrolujte množstvo tekutiny v nádobe. Pridajte 150 ml teplej vody, ak je to potrebné. Zatvorte veko. Počkajte, kým program skončí. Podávajte s čerstvým chrumkavým chlebom a trochu oleja s ostrým čili.

SIRUPOVÝ SPONGE PUDDING (KOLÁČIK)

PARA

115 g	maslo	2	60
100 g	práškový cukor	¼	☞ vanilková esencia
175 g	múka s prísadou kypriaceho prášku	2	☞ mlieko
4	golden syrup (zlatý - trstinový sirup)		

V miske rozšľahajte vajcia. V nádobe vymiešajte maslo s cukrom. Postupne pridávajte vajíčka, potom vanilku, potom múku. Vmiešajte mlieko. Vymastite ohňovzdornú misu s objemom 1200 ml. Sirup nalejte na dno ohňovzdornej nádoby a položte naň zmes. Prikryte papierom na pečenie, potom alobalom a vrchnú časť stiahnite šnúrkou. Otvorte veko. Ohňovzdornú nádobu vložte do nádoby v prístroji. Do nádoby v prístroji pridajte dostatok vriacej vody, aby siahala 3 cm pod vrchnú časť ohňovzdornej nádoby. Zatvorte veko. Zvoľte v menu . Nastavte čas prípravy na 1 hodinu 30 minút. Stlačte tlačidlo . Počkajte, kým program skončí. Prevráťte na tanier a podávajte teplé. Toto je vynikajúci koláč kedykoľvek v roku.

OVSENÁ KAŠA

2	☞	ovsená múka
1¼	☞	soľ

porcií:

tmavohnedý cukor

OVSENÁ KAŠA/RIZOTO

		voda
2	☞	cukor

mlieko / smotana na varenie

Otvorte veko. Pridajte ovsenú múku, soľ a cukor. Naplňte vodou po úroveň 1½ na stupnici vpravo vo vnútri nádoby. Zatvorte veko. Zvoľte na menu a stlačte . Počkajte, kým program skončí. Podávajte s mliekom alebo smotanou. Posypte tmavým hnedým cukrom. Ak chcete, môžete 15 minút pred ukončením času varenia pridať nakrájané sušené marhule alebo polovicu kúcky sušených sliviek (odkóstkované). Nedojedaná ovsená kaša vydrží v chladničke až 2 dni, potom sa zohreje.



ORECHOVÁ KAŠA

½	☞	ovsené vločky
120 ml		mlieko
1	☞	mletej škorice

porcií:

golden syrup (zlatý - trstinový sirup)

OVSENÁ KAŠA/RIZOTO

		voda
3	☞	sušený kokos

posekané mandle

Otvorte veko. Pridajte vločky, škoricu, kokos a mlieko. Naplňte vodou po úroveň ½ na stupnici vpravo vo vnútri nádoby. Zatvorte veko. Zvoľte na menu a stlačte . Počkajte, kým program skončí. Pokropte sirupom golden a povrch posypte posekanými mandľami.

CVIKLOVÉ RIZOTO V MULTIVARNOM HRNCI

400 g	cvikla
250 g	ryža arbori na rizoto
250 ml	biele víno
900 ml	zeleninový bujón / kuracieho vývaru

na dokončenie:

100 ml	jogurt
1	☞ maslo

OVSENÁ KAŠA/RIZOTO

2	☞	olivový olej
1		cibuľa, nakrájaná na jemno
2	☞	cesnak, ošúpaný a pokrájaný
1	☞	tymián, nakrájaný na jemno

1 ☞ petržlen (nasekaný)

Otvorte veko. Zvoľte na menu a stlačte . Pridajte bujón. Privedte do varu, za stáleho miešania. Varte na miernom ohni 10 minút. Vývar prelejte do krčaha. Na zastavenie programu stlačte dvakrát. Zvoľte na menu a stlačte . Nechajte ju zohriať. Ošúpte cviklu a nakrájajte na 1 cm kocky. Cviklu, cesnak a cibuľu vložte do nádoby. Varte, pokým cibuľa nezmäkne. Vmiešajte ryžu. Zatvorte vrchnák a varte 3-4 minúty. Otvorte veko. Vmiešajte víno. Zatvorte vrchnák a varte 3-4 minúty. Otvorte veko. Pridajte tymian. Pridajte bujón. Zatvorte veko. Počkajte, kým program skončí. Skontrolujte ryžu – mala by ísť trochu na zub, ale nemala by byť príliš tvrdá. Ak ešte nie je celkom hotová, pridajte trochu vody a varte niekoľko minút dlhšie. Vmiešajte maslo – to dodá rizotu jeho lesk. Podávajte s kôpkou jogurtu a posypte petržlenom. Toto je naozaj dobré ako predjedlo alebo ľahký obed.

RÝCHLY CHLIEB (SO SÓDOU BIKARBÓNOU)

CHLIEB

maslo 350 ml voda

zmes na výrobu rýchleho chleba (so sódou bikarbónou)

Otvorte veko. Nádobu vymastíte maslom. Zvoľte v menu . Zatvorte veko. Nastavte čas prípravy na 2 hodiny 15 minút. Stlačte tlačidlo . Nechajte ju zohriať. Vložte do nádoby zmes na rýchly chlieb. Pridajte vodu. Rukou vymiešajte do gule. Otvorte veko. Cesto vložte do nádoby. Rozdeľte cesto na štvrtiny plastovou vareškou. Zatvorte veko. 30 minút pred ukončením varenia otvorte vrchnák. Otočte chlieb naopak. To pomôže dodať vrchnej časti bochníka trochu farby a chrumkavosti. Počkajte, kým program skončí. Nechajte vychladnúť vyklopené na mriežke. Podávajte samostatne so soleným maslom alebo s iným jedlom.

BIELY BOCHNÍK

CHLIEB

golden syrup (zlatý - trstinový syrup)
320 ml mlieko
500 g múka na chlieb

maslo
 sušené droždie
 soľ

Otvorte veko. Pridajte mlieko. Zvoľte na menu a stlačte . Nechajte mlieko zohriať, až kým sa na okrajoch netvorí bubliny. Prelejte mlieko do džbána. Na zastavenie programu stlačte dvakrát. Nechajte mlieko vychladnúť na 37°C až 45°C. V panvici na miernom ohni rozpustite maslo. Zmiešajte v miske múku a soľ. Pridajte kvasnicu, maslo a syrup. Pridajte mlieko a vymiešajte do gule. Ak je zmes veľmi lepkavá, pridajte trochu viac múky. Prikrýte a nechajte 10 minút na teplom mieste. Znovu premiešajte. Prikrýte a nechajte 10 minút na teplom mieste. Otvorte veko. Zvoľte na menu a stlačte . Zatvorte veko. 30 minút pred ukončením varenia otvorte vrchnák. Otočte chlieb naopak. To pomôže dodať vrchnej časti bochníka trochu farby a chrumkavosti. Počkajte, kým program skončí. Podávajte s nádielkou masla.

CHUTNÁ RYŽA

RYŽA

ryža
1 bujón (zeleninový)
1 červená paprika, bez semien a pokrájaná
 kurkuma

voda
2 mrkva, nakrájaná
2 stopkový zeler, pokrájaný
 hrášok (nemusí byť)

Otvorte veko. Ryžu dajte do nádoby. Naplňte vodou po úroveň 2 na stupnici vľavo vo vnútri nádoby. Rozmrvte kocku bujónu a vmiešajte ju do vody. Pridajte zostávajúce prísady. Zatvorte veko. Zvoľte . Počkajte, kým program skončí, potom podávajte. Ak ryža nie je celkom urobená, nechajte ju niekoľko minút pod zatvoreným vrchnákom pariť.

PARADAJKOVÁ VEĽKÁ POLIEVKA

POLIEVKA

1 cibuľa, pokrájaná
 krájaných paradajok
1 červená paprika, bez semien a pokrájaná
550 ml kuracieho vývaru
 sušenej bylinkovej zmesi

olivový olej
2 krájaných paradajok
2 zemiaky
 paradajkové pyré
 čierne korenie

Otvorte veko. Pridajte bujón. Zvoľte na menu a stlačte . Privedte do varu, za stáleho miešania. Varte na miernom ohni 10 minút. Vývar prelejte do krčaha. Na zastavenie programu stlačte dvakrát. Ošúpte paradajky a nakrájajte ich na kocky. Zvoľte na menu a stlačte . Pridajte olej. Pridajte cibuľu a sladkú papriku. Varte, pokým cibuľa nezmäkne. Pridajte bujón. Pridajte zostávajúce prísady. Zatvorte veko. Počkajte, kým program skončí. Ochuťte podľa vlastnej chuti. Podávajte s chrumkavým chlebom.

KAPUSTOVO-JABLKOVÁ POLIEVKA S KLOBÁSOU CHORIZO

POLIEVKA 🍲

- ¼ klobása chorizo, nakrájaná na jemno
- 1 jablko
- 2 🍴 stopkový zeler, pokrájaný
- ¼ jarná kapusta, nakrájaná na jemno
- 2 🧄 cesnak, ošúpaný a pokrájaný
- 1 🧂 soľ
- 850 ml zeleninový bujón

- 1 cibuľa, nakrájaná na jemno
- 2 mrkva, nakrájaná
- 2 krájaných paradajok
- 1 🍴 paradajkové pyré
- 1 🍴 cayenské korenie
- 1 🍴 čierne korenie

Otvorte veko. Zvoľte na menu 🍲 a stlačte ⏏. Klobásu chorizo opekajte 2 minúty. Pridajte cibuľu a cesnak. Varte, pokým cibuľa nezmäkne. Jablko ošúpte, zbavte jadrovníka a nakrájajte. Pridajte zostávajúce prísady. Na zastavenie programu stlačte ⏏ dvakrát. Zatvorte veko. Zvoľte na menu 🍲 a stlačte ⏏. Počkajte, kým program skončí. Toto je vynikajúca polievka a ak ju necháte cez noc v chladničke, chuť sa ešte rozvinie.

KURČA S PARADAJKAMI A HUBAMI

MÄSO 🍲

- 2 kuracie prsia, bez kosti a kože
- 450 g hnedé huby, nakrájané
- 2 🧄 cesnak, ošúpaný a pokrájaný
- 1 🍴 worcestrovej omáčky
- soľ a čierne korenie

- 1 🍴 olivový olej
- 1 🍴 krájaných paradajok
- 1 🍴 paradajková omáčka
- 1 🍴 sušeného oregana

Otvorte veko. Zvoľte na menu 🍲 a stlačte ⏏. Pridajte olej. Kuracie prsia ochuťte soľou a čiernym korením a vložte ich do nádoby. Mäso otočte, aby ste uzavreli obe strany. Pridajte cesnak a huby. Pripravujte 3 – 4 minúty, kurča raz otočte. Pridajte paradajky, Worcestrovú omáčku, paradajkovú omáčku a oregano. Pokračujte vo varení, kurča znovu otočte. Skontrolujte, či je kurča prepečené. Podávajte s cestovinami, zemiakmi alebo ryžou. Rýchle a chutné jedlo zo surovín v skriní.

REBIERKA NA TMAVOM PIVE STOUT S JAVOROVÝM SIRUPOM A SÓJOVOU OMÁČKOU

MÄSO 🍲

- 1 kg bravčové rebierka
- 350 ml pivo Guinness / stout
- 140 ml Hovädzí vývar / bravčový vývar
- 60 ml javorový sirup / med

- 1 cibuľa, pokrájaná
- 1 🍴 olivový olej
- 3 🧄 cesnak, ošúpaný a pokrájaný
- 2 🍴 tmavá sójová omáčka

Otvorte veko. Zvoľte v menu 🍲. Pridajte olej. Nastavte čas prípravy na 1 hodinu 45 minút. Stlačte tlačidlo ⏏. Pridajte rebierka a opekajte 5 minút – občas otočte. Rebierka vyberte. Pridajte cibuľu a cesnak. Varte, pokým cibuľa nezmäkne. Vráťte rebierka do nádoby. Vmiešajte Guinness, vývar, javorový sirup a sójovú omáčku. Zatvorte veko. Počkajte, kým program skončí. Pridajte korenie a podávajte. Vynikajúce predjedlo alebo ako súčasť obeda s viacerými možnosťami.

HRNIEC S HOVÄDZÍM BÔČIKOM

POMALÉ VARENIE 🍲

- 1 kg hovädzí bôčik
- 2 🧄 cesnak, ošúpaný a pokrájaný
- 50 g klobása chorizo, nakrájaná na kolieska
- 2 červené cibule, nakrájané
- 600 ml hovädzí vývar
- 2 🍴 sušenej bylinkovej zmesi
- 6-8 zemiaky (malé)
- 2 🍴 worcestrovej omáčky

- 2 🍴 paradajkové pyré
- 2 🍴 bobkový list
- 2 mrkva
- 3 🍴 zeler
- 2 🍴 rozmarín, nasekaný
- 1 🍴 krájaných paradajok
- soľ a čierne korenie

Zemiaky nechajte v šupke. Nakrájajte zemiaky, mrkvy a zeler na kúsky. Bôčik ochuťte soľou a čiernym korením. Otvorte veko. Zvoľte na menu 🍲 a stlačte ⏏. Pridajte bujón. Privedte do varu, za stáleho miešania. Varte na miernom ohni 10 minút. Vývar prelejte do krčaha. Klobásu chorizo opekajte 2 minúty. Pridajte mäso. Opečte z každej strany. Pridajte cibule, cesnak, zemiaky, zeler a mrkvy. Ak máte akúkoľvek inú koreňovú zeleninu, ktorú potrebujete spotrebovať, pridajte ju tiež. Varte, pokým cibuľa nezmäkne. Pridajte bujón. Pridajte zostávajúce prísady. Na zastavenie programu stlačte ⏏ dvakrát. Zvoľte 🍲. Počkajte, kým program skončí, potom podávajte. Varenie 8 hodín tomu neublíži, ale pravdepodobne to bude pripravené na jedenie po 5 hodinách.



instrukcję należy przeczytać, zachować, przekazać kolejnemu użytkownikowi, jeśli odstępujemy urządzenie innej osobie. Wyjmij z opakowania przed użyciem.

WSKAZÓWKI DOTYCZĄCE BEZPIECZEŃSTWA

Postępuj zgodnie ze wskazówkami dotyczącymi bezpieczeństwa, między innymi:

Urządzenie może być użytkowane przez dzieci w wieku od 8 lat i starsze oraz osoby o ograniczonej sprawności fizycznej, czuciowej lub psychicznej lub osoby niemające doświadczenia lub znajomości urządzenia, jeśli odbywa się to pod nadzorem / z instruktążem, oraz są świadome istniejących zagrożeń. Dzieci nie powinny bawić się urządzeniem. Dzieci nie powinny czyścić i obsługiwać urządzenia, o ile nie są starsze niż 8 lat i są nadzorowane. Przechowuj urządzenie i przewód zasilania w miejscu niedostępnym dla dzieci w wieku poniżej 8 lat.

Jeśli złączka lub kabel są uszkodzone, można je zastąpić tylko poprzez specjalny zestaw dostępny u producenta lub w autoryzowanym serwisie.

⊘ Nie należy używać tego urządzenia w pobliżu wanny, prysznic, umywalki lub innych naczyń zawierających wodę.

⚠ Niewłaściwe użytkowanie urządzenia może spowodować obrażenia ciała.

⚠ Powierzchnie urządzenia rozgrzewają się. Resztkowe ciepło powoduje, że powierzchnie jeszcze pozostają gorące po użyciu.

- Nie wkładaj zamrożonego mięsa lub drobiu w urządzenie - przed użyciem trzeba je całkowicie rozmrozić.
- Piecz mięso, drób, i ich pochodne (mielone, hamburgery, itp.), aż będzie wyciekać czysty sos. Przyrządzaj ryby, aż w całości będą gotowe do spożycia.
- Nie staraj się gotować czegokolwiek w korpusie urządzenia – gotuj tylko w wyjmowanej misie.
- Nie napełniaj ponad max.
- Nie przykrywaj urządzenia i niczego na nim nie stawiaj.
- Wyjmij wtyczkę z gniazdka, a następnie wyjmij złączkę zasilania urządzenia.
- Odłącz urządzenie od sieci, kiedy nie jest używane.
- Nie używaj innych akcesoriów niż te, które są dostarczone z urządzeniem.
- Nigdy nie używaj urządzenia niezgodnie z jego przeznaczeniem określonym w niniejszej instrukcji.
- Nigdy nie używaj uszkodzonego urządzenia lub jeśli zaczęło wadliwie działać.

TYLKO DO UŻYTKU DOMOWEGO



RYСУNKI

- | | |
|-----------------------|------------|
| 1. Sterowania | 5. Miarka |
| 2. Pokrywa | 6. Kosz |
| 3. Błokada pokrywy | 7. Miska |
| 4. Pokrywa wewnętrzna | 8. Złączka |



PRZYGOTOWANIE

1. Ustaw urządzenie na stabilnej, równej i termoodpornej powierzchni.
2. Nie należy umieszczać urządzenia w pobliżu zasłon, pod półkami lub szafkami ani w pobliżu czegokolwiek, co mogłoby zostać uszkodzone przez uciekającą parę.
3. Zakładaj żaroodporne lub tkaninowe rękawice kuchenne oraz żaroodporne podkładki lub talerze do ustawienia miski po ugotowaniu.
4. Umieść miskę wewnątrz szybkowaru.
5. Obróć miskę ćwierć obrotu w każdą stronę, aby dno miski lepiej przylegało do grzałki.



RYŻ

1. Użyj miarki do wsypania ryżu do miski.
2. Nie należy wsypać więcej niż 10 filiżanek ryżu.
3. Zastosuj skalę po lewej stronie, wewnątrz miski, na której są oznaczenia od 2 do 10
4. Napełnij miskę wodą w ilości odpowiadającej liczbie filiżanek, wsypanego ryżu.
5. Zamknij pokrywę.
6. Naciśnij przycisk . Podświetli się przycisk.
7. W czasie podgrzewania produktów migają zewnętrzne segmenty wyświetlacza.
8. Wyświetlacz będzie wyświetlał pozostały czas gotowania (13 minut) i odliczać czas.
9. Na koniec czasu gotowania, urządzenie przejdzie do trybu "Podtrzymywanie temperatury".
10. Będzie się świecić lampka .
11. Otwórz pokrywę.
12. Podnieś miskę i ustaw na żaroodpornej podkładce lub talerzu.
13. Naciśnij przycisk .
14. Przemieszaj ryż łyżką, aż wyleci cała para.
15. Niekiedy warstwa przylegająca do miski utworzy skorórkę.
16. Jeśli jednak nie lubisz takiej skorórkę, usuń ją łyżką służącą do nakładania ryżu.

WOLNE GOTOWANIE





1. Zrumienianie mięsa i warzyw (patrz "ZRUMIENIANIE/PODSMAŻANIE/ZMIĘKCZANIE/GOTOWANIE").
2. Zagotuj płyn (patrz "ZRUMIENIANIE/PODSMAŻANIE/ZMIĘKCZANIE/GOTOWANIE").
3. Włóż składniki stałe w miskę, a następnie zlej płynem.
4. Zamknij pokrywę.
5. Naciśnij przycisk . Podświetli się przycisk.
6. Na wyświetlaczu wyświetli się 8 godzin i zacznie się odliczanie.
7. Na koniec czasu gotowania, urządzenie przejdzie do trybu "podtrzymywanie temperatury".
8. Będzie się świecić lampka .
9. Naciśnij przycisk . Otwórz pokrywę. Wyjmij jedzenie.

DUSZENIE





1. Zrumienianie mięsa i warzyw (patrz "ZRUMIENIANIE/PODSMAŻANIE/ZMIĘKCZANIE/GOTOWANIE").
2. Zagotuj płyn (patrz "ZRUMIENIANIE/PODSMAŻANIE/ZMIĘKCZANIE/GOTOWANIE").
3. Włóż składniki stałe w miskę, a następnie zlej płynem.
4. Zamknij pokrywę.
5. Naciśnij przycisk . Podświetli się przycisk.
6. Na wyświetlaczu wyświetli się 1 godzina i rozpocznie się odliczanie.
7. Na koniec czasu gotowania, urządzenie przejdzie do trybu "Podtrzymywanie temperatury".
8. Będzie się świecić lampka .
9. Naciśnij przycisk . Otwórz pokrywę. Wyjmij jedzenie.



MIĘSO

1. Natrzyj mięso olejem kuchennym.
2. Natrzyj mięso przyprawami.
3. Wlej łyżkę oleju kuchennego do miski.
4. Włóż mięso do miski.
5. Zamknij pokrywę.
6. Czas zależy od wielkości potrawy.
7. Gotuj nie więcej niż około 500 g składników na raz.
8. Sugerowany czas obróbki cieplnej to 10 minut + 10 minut na każde 100 g wołowiny.
9. Mięso wieprzowe i drobiowe powinno być obrabiane cieplnie nie krócej jak przez 5, 10, 15, 20, 25, 30 minut.
10. Przy pomocy przycisku  wybierz  w menu .
11. Wybór czasu gotowania. Domyślny czas wynosi 20 minut.
12. Przyciski h i min działają tylko wtedy, gdy miga czas na wyświetlaczu.
13. Użyj przycisku min, aby przechodzić na wyświetlaczu przez opcje (10, 15, 20, 25, 5, 10, 15, 20, 25, 30, 35, 40, 45, 50 i 55).
14. Jeśli gotowanie ma trwać 1 godzinę, naciśnij przycisk h.
15. Aby cofnąć ustawienie 1-godzinne, ponownie naciśnij przycisk h, a na wyświetlaczu czas zacznie ponownie migać.
- Jeśli przez 2 minuty nic się nie dzieje, urządzenie przejdzie w tryb gotowości.
16. Po ustawieniu czasu, naciśnij przycisk .
17. Wyświetlacz zacznie odliczać.
18. Na koniec czasu gotowania, urządzenie przejdzie do trybu "Podtrzymywanie temperatury".
19. Będzie się świecić lampka .
20. Naciśnij przycisk . Otwórz pokrywę. Wyjmij jedzenie.

ZUPA

1. Zrumienianie mięsa i warzyw (patrz "ZRUMIENIANIE/PODSMAŻANIE/ZMIĘKCZANIE/GOTOWANIE").
2. Włóż składniki stałe w miskę, a następnie zlej płynem.
3. Zamknij pokrywę.
4. Przy pomocy przycisku  wybierz  w menu .
5. Wybór czasu gotowania. Domyślny czas wynosi 1 godzinę.
6. Przyciski h i min działają tylko wtedy, gdy miga czas na wyświetlaczu.
7. Użyj przycisku min, aby przechodzić na wyświetlaczu przez opcje (10, 15, 20, 25, 5, 10, 15, 20, 25, 30, 35, 40, 45, 50 i 55).
8. Użyj przycisku h, aby przechodzić na wyświetlaczu przez opcje (1, 2, 3, 4 i 5).
9. Aby cofnąć ustawienie 5-godzinne, ponownie naciśnij przycisk h, a na wyświetlaczu czas zacznie ponownie migać.
- Jeśli przez 2 minuty nic się nie dzieje, urządzenie przejdzie w tryb gotowości.
10. W programie istnieje opcja ustawiania regulatora czasowego (patrz REGULATOR CZASOWY).
11. Naciśnij przycisk .
12. Wyświetlacz zacznie odliczać.
13. Na koniec czasu gotowania, urządzenie przejdzie do trybu "Podtrzymywanie temperatury".
14. Będzie się świecić lampka .
15. Naciśnij przycisk . Otwórz pokrywę. Wyjmij jedzenie.

JOGURT

Kultura bakterii jogurtu

Możesz użyć 5, 10, 15, 20, 25, 30 ml (2 łyżki):

- Żywego jogurtu bez dodatku substancji smakowych - musi być świeży (sprawdź termin przydatności do spożycia). Różne marki dadzą różne wyniki.

Jogurtu zrobionego wcześniej.

- Bakterie osłabiają się w czasie, te same można wykorzystać tylko 10 razy, później trzeba użyć nowej kultury bakterii.





Liofilizowana kultura bakterii jogurtu z apteki lub sklepu ze zdrową żywnością

- Jeżeli wskazówki na etykiecie opakowania różnią się od podanych w tej instrukcji, postępuj zgodnie ze wskazówkami na opakowaniu.

Mleko



1. Jest potrzebny 1 litr mleka.
2. Mleko pełne daje jogurt pełniejszy niż otrzymany z mleka o niskiej zawartości tłuszczu.
3. Aby jogurt jeszcze bardziej zagęścić, do mleka można dodać do 8 łyżek mleka w proszku.
4. Można również zastosować odtworzone mleko w proszku lub mleko zagęszczone z puszki.



Robienie jogurtu

1. Bakterie w mleku trzeba zabić, aby zapobiec ich konkutowaniu z kulturami bakterii jogurtu.
 2. Niech kultura bakterii jogurtu osiągnie temperaturę pokojową w czasie, gdy podgrzewasz mleko.
 3. Otwórz pokrywę.
 4. W programie GOTOWANIE NA PARZE (ZRUMIENIANIE/PODSMAŻANIE/ZMIĘKCZANIE/GOTOWANIE) można zagrzać mleko nieco poniżej temperatury wrzenia.
 5. Niech mleko się podgrzeje do chwili, gdy zaczną tworzyć się bańki na krawędziach.
 6. Ostudź mleko do temperatury między 37°C a 45°C.
 7. Wmieszaj kulturę bakterii jogurtu w mleko.
 8. Musisz dokładnie wmieszać, inaczej jogurt będzie grudkowaty.
 9. Zamknij pokrywę.
 10. Przy pomocy przycisku  wybierz  w menu .
 11. Wybór czasu gotowania. Domyślny czas wynosi 8 godzin.
 12. Przyciski h i min działają tylko wtedy, gdy miga czas na wyświetlaczu.
 13. Użyj przycisku min, aby przechodzić na wyświetlaczu przez opcje (10, 15, 20, 25, 5, 10, 15, 20, 25, 30, 35, 40, 45, 50 i 55).
 14. Użyj przycisku h, aby przechodzić na wyświetlaczu przez opcje (6, 7, 8, 9 i 10).
 15. Aby cofnąć ustawienie 10-godzinne, ponownie naciśnij przycisk h, a na wyświetlaczu czas zacznie ponownie migać.
- Jeśli przez 2 minuty nic się nie dzieje, urządzenie przejdzie w tryb gotowości.
16. W programie istnieje opcja ustawiania regulatora czasowego (patrz REGULATOR CZASOWY).
 17. Naciśnij przycisk .
 18. Wyświetlacz zacznie odliczać.
 19. Na koniec czasu przyrządzania, urządzenie przejdzie do trybu gotowości.
 20. Nie będzie podtrzymywana temperatura jogurtu.
 21. Naciśnij przycisk . Otwórz pokrywę. Wyjmij jedzenie.







CHLEB



1. Należy bezpośrednio przez użyciem rozmrozić zamrożone ciasto.
 2. Gotuj nie więcej niż około 500 g składników na raz.
 3. Natrzyj miskę olejem kuchennym.
 4. Przełóż ciasto do miski.
 5. Zamknij pokrywę.
 6. Przy pomocy przycisku  wybierz  w Menu.
 7. Wybór czasu gotowania. Domyślny czas wynosi 3 godzin.
 8. Przyciski h i min działają tylko wtedy, gdy miga czas na wyświetlaczu.
 9. Użyj przycisku min, aby przechodzić na wyświetlaczu przez opcje (10, 15, 20, 25, 5, 10, 15, 20, 25, 30, 35, 40, 45, 50 i 55).
 10. Użyj przycisku h, aby przechodzić na wyświetlaczu przez opcje (1, 2, 3, 4, 5 i 6).
 11. Aby cofnąć ustawienie 6-godzinne, ponownie naciśnij przycisk h, a na wyświetlaczu czas zacznie ponownie migać.
- Jeśli przez 2 minuty nic się nie dzieje, urządzenie przejdzie w tryb gotowości.

12. W programie istnieje opcja ustawiania regulatora czasowego (patrz REGULATOR CZASOWY).
13. Naciśnij przycisk .
14. Wyświetlacz zacznie odliczać.
15. Na koniec czasu gotowania, urządzenie przejdzie do trybu "Podtrzymywanie temperatury".
16. Będzie się świecić lampka .
17. Naciśnij przycisk . Otwórz pokrywę. Wyjmij jedzenie.



RYBY

1. Natrzyj mięso olejem kuchennym.
2. Natrzyj mięso przyprawami.
3. Wlej łyżkę oleju kuchennego do miski.
4. Włóż mięso do miski.
5. Zamknij pokrywę.
6. Czas zależy od wielkości potrawy.
7. Gotuj nie więcej niż około 500 g składników na raz.
8. Sugerowany czas obróbki cieplnej to 10 minut + 10 minut na każde 100 g wagi.
9. Przy pomocy przycisku  wybierz  w menu .
10. Wybór czasu gotowania. Domyślny czas wynosi 20 minut.
11. Przyciski h i min działają tylko wtedy, gdy miga czas na wyświetlaczu.
12. Użyj przycisku min, aby przechodzić na wyświetlaczu przez opcje (10, 15, 20, 25, 5, 10, 15, 20, 25, 30, 35, 40, 45, 50 i 55).
13. Jeśli gotowanie ma trwać 1 godzinę, naciśnij przycisk h.
14. Aby cofnąć ustawienie 1-godzinne, ponownie naciśnij przycisk h, a na wyświetlaczu czas zacznie ponownie migać.
 - Jeśli przez 2 minuty nic się nie dzieje, urządzenie przejdzie w tryb gotowości.
15. Po ustawieniu czasu, naciśnij przycisk .
16. Wyświetlacz zacznie odliczać.
17. Na koniec czasu gotowania, urządzenie przejdzie do trybu "Podtrzymywanie temperatury".
18. Będzie się świecić lampka .
19. Po przyrządzeniu, jedzenie najlepiej od razu wyjąć z urządzenia, aby nie wysuszyło.
20. Naciśnij przycisk . Otwórz pokrywę. Wyjmij jedzenie.

GOTOWANIE NA PARZE

1. Napełnij miskę zimną wodą do oznaczenia 6.
2. Nałóż kosz na miskę i włóż do niego produkty.
3. Aby produkty gotowały się równomiernie, potnij je na w przybliżeniu tej samej wielkości kawałki.
4. W przypadku grochu, czy innych produktów, które mogą się rozpaść lub wpadać do wody, zawinąć je w folię aluminiową.
5. Przy wyjmowaniu jedzenia zawiniętego w folię, należy zachować ostrożność - założyć rękawice kuchenne i używać plastikowych szczypców/łyżek.
6. Zamknij pokrywę.
7. Przy pomocy przycisku  wybierz  w menu .
8. Wybór czasu gotowania. Domyślny czas wynosi 30 minut.
 - Te składniki powinny być gotowane w czasie domyślnym:

Jedzenie (świeże)	Ilość
Zielona fasola	200g
Brukselka	200g
Marchew (w plastrach)	200g
Ziemniaki (ćwiartki)	400g
Brokuł	200g
Kapusta	Ćwiartka
Kukurydza w kolbach	2

9. Przyciski h i min działają tylko wtedy, gdy miga czas na wyświetlaczu.
10. Użyj przycisku min, aby przechodzić na wyświetlaczu przez opcje (5, 10, 15, 20, 25, 30, 35, 40, 45, 50 i 55).
11. Użyj przycisku h, aby przechodzić na wyświetlaczu przez opcje (1 i 2).
12. Aby cofnąć ustawienie 2-godzinne, ponownie naciśnij przycisk h, a na wyświetlaczu czas zacznie ponownie migać.
 - Jeśli przez 2 minuty nic się nie dzieje, urządzenie przejdzie w tryb gotowości.
13. W programie istnieje opcja ustawiania regulatora czasowego (patrz REGULATOR CZASOWY).
14. Naciśnij przycisk .
15. Wyświetlacz zacznie odliczać.
16. Na koniec czasu gotowania, urządzenie przejdzie do trybu "Podtrzymywanie temperatury".
17. Będzie się świecić lampka .
18. Po przyrządzeniu, jedzenie najlepiej od razu wyjąć z urządzenia, aby nie było papkowane.
19. Naciśnij przycisk . Otwórz pokrywę. Wyjmij jedzenie.

ZRUMIENIANIE/PODSMAŻANIE/DUSZENIE/GOTOWANIE

- Można wykorzystać program GOTOWANIE NA PARZE  w ustawieniu domyślnym, przy otwartej pokrywie, jako gorącą patelnię, przez 5, 10, 15, 20, 25, 30 minut, przed obróbką cieplną w innym programie.
- Można stosować po wlaniu niewielkiej ilości oliwy do przyrumienienia mięsa i warzyw, podsmażania, aby zmiękczyć cebulę, seler, pory, ...
- Można wykorzystywać do wstępnego podgrzewania płynów jak woda lub bulion.
- Po włączeniu programu głównego, urządzenie jest już rozgrzane, a niektóre lub wszystkie składniki już są w misce.
- Nie ma wtedy potrzeby mycia patelni użytej w przygotowywaniu produktów.





OWSIANKA/RISOTTO



Stosując miarkę wsyp ziarna (ryżu, owsa, jęczmienia, itp.) do miski.

Owsianka

- Zastosuj skalę po prawej stronie, wewnątrz miski, na której są oznaczenia od ½ do 1½.
- Nie napełniaj ponad **max**.

Kaszka





- Zastosuj skalę znajdującą się w środku, wewnątrz miski, na której są oznaczenia od 1 do 3.
 - Nie napełniaj ponad **max**.
1. Napełnij miskę wodą w ilości odpowiadającej liczbie filiżanek wsypanej kaszy.
 2. Zamknij pokrywę.
 3. Przy pomocy przycisku  wybierz  w menu.
 4. Wybór czasu gotowania. Domyślny czas wynosi 1 godzinę.
 5. Przyciski h i min działają tylko wtedy, gdy miga czas na wyświetlaczu.

6. Użyj przycisku min, aby przechodzić na wyświetlaczu przez opcje (5, 10, 15, 20, 25, 30, 35, 40, 45, 50 i 55).
7. Użyj przycisku h, aby przechodzić na wyświetlaczu przez opcje (1, 2, 3 i 4).
8. Aby cofnąć ustawienie 4-godzinne, ponownie naciśnij przycisk h, a na wyświetlaczu czas zacznie ponownie migać.
 - Jeśli przez 2 minuty nic się nie dzieje, urządzenie przejdzie w tryb gotowości.
9. W programie istnieje opcja ustawiania regulatora czasowego (patrz REGULATOR CZASOWY).
10. Naciśnij przycisk .
11. Wyświetlacz zacznie odliczać.
12. Na koniec czasu gotowania, urządzenie przejdzie do trybu "Podtrzymywanie temperatury".
13. Będzie się świecić lampka .
14. Naciśnij przycisk . Otwórz pokrywę. Wyjmij jedzenie.



Risotto

Postępuj według przepisu w tej książce.









CIASTO

1. Należy bezpośrednio przez użyciem rozmrozić zamrożone ciasto.
2. Nie napełniaj miski więcej niż w połowie.
3. Natrzyj miskę olejem kuchennym.
4. Przełóż ciasto do miski.
5. Zamknij pokrywę.
6. Przy pomocy przycisku  wybierz  w menu .
7. Wybór czasu gotowania. Domyślny czas wynosi 40 minut.
8. Domyślny czas wynosi 40 minut.
9. Przyciski h i min działają tylko wtedy, gdy miga czas na wyświetlaczu.
10. Użyj przycisku min, aby przechodzić na wyświetlaczu przez opcje (5, 10, 15, 20, 25, 30, 35, 40, 45, 50 i 55).
11. Użyj przycisku h, aby przechodzić na wyświetlaczu przez opcje (1 i 2).
12. Aby cofnąć ustawienie 2-godzinne, ponownie naciśnij przycisk h, a na wyświetlaczu czas zacznie ponownie migać.
 - Jeśli przez 2 minuty nic się nie dzieje, urządzenie przejdzie w tryb gotowości.
13. Po ustawieniu czasu, naciśnij przycisk .
14. Wyświetlacz zacznie odliczać.
15. Na koniec czasu gotowania, urządzenie przejdzie do trybu "Podtrzymywanie temperatury".
16. Będzie się świecić lampka .
17. Po przyrządzeniu, jedzenie najlepiej od razu wyjąć z urządzenia, aby nie było papkowane.
18. Naciśnij przycisk . Otwórz pokrywę. Wyjmij jedzenie.

PODTRZYMYWANIE TEMPERATURY

- Jeśli chcesz używać funkcji podtrzymywania temperatury po programie, który jej nie przewiduje, wtedy, jeśli na wyświetlaczu miga  naciśnij przycisk .
- Naciśnij przycisk , aby wyjść z tej funkcji.

REGULATOR CZASOWY

- Użytkownik może wykorzystywać regulator czasowy w programach zupa , jogurt , chleb , para  i owsianka .
 - Należy to zrobić od razu po ustawieniu czasu gotowania, przed naciśnięciem przycisku start .
1. Naciśnij przycisk . Będzie się świecić lampka .
 2. Określ, kiedy jedzenie ma być gotowe.
 3. Na przykład, jeśli teraz jest godzina 2:00, jedzenie ma być gotowe godz. 9:00, należy ustawić czas na 7 godzin.
 4. Użyj h i min, aby ustawić właściwą godzinę i minutę.
 5. Naciśnij przycisk .

KONSERWACJA I OBSŁUGA







1. Wyjmij wtyczkę z gniazdka i ostudź urządzenie.
2. Wyjmij wtyczkę z gniazdka, a następnie wyjmij złączkę zasilania urządzenia.
3. Przy pokrywie zamkniętej, chwyć górną część filtra i wyjmij go z pokrywy (Rys. A).
4. Obróć go, aby odsłonić znaki na przedniej krawędzi.
5. Przytrzymaj pokrywę filtra i obróć resztę filtra w kierunku otwartej kłódki  (Rys. B).
6. Naciśnij na zaczepy na dole pokrywy wewnętrznej i wyciągnij go z urządzenia (Rys. C).
7. Inne części należy myć ręcznie.
8. Wytrzyj wszystkie powierzchnie czystą wilgotną szmatką.
9. Żadna część urządzenia nie może być myta w zmywarce do naczyń.
10. Złóż filtr, i ponownie go załóż w pokrywie.
11. Ponownie wstaw pokrywę wewnętrzną w pokrywę.



RECYKLING







Aby uniknąć problemów środowiskowych i zdrowotnych spowodowanych niebezpiecznymi substancjami, sprzętu, akumulatorów i baterii oznaczonych jednym z tych symboli nie należy wyrzucać z nieposortowanymi odpadami komunalnymi. Produkty elektryczne i elektroniczne, w tym, baterie jednorazowe i akumulatory, należy zawsze utylizować w odpowiednim publicznym punkcie zbiórki odpadów/recyklingu.

PRZEPISY KULINARNE

	łyżka stołowa (15ml)
	łyżeczka (5 ml)
g	gramy
ml	mililitry
	miarka
	łodyga (selera)
	garść
	jajo, średnie (53-63 g)

	szczypta
	pęczek
	gałązka
	ząbek(ki)
	puszka
	słoik
	torebka (7g)
	jajo, duże (63-73 g)

CHILI W WARZYWACH I KUSKUS









1	czerwona cebula, drobno posiekana
1	duża cebula, drobno posiekana
2 	czosnek, obrany i posiekany
1	czerwona papryka, bez nasion i posiekana
1	żółta papryka, bez nasion i posiekana
1 	krojone pomidory
2 	zmielony kminek
850 ml	wywar z warzyw
2 	chilli w proszku
120-140 ml	kuskus
1	pomarańczowa papryka, bez nasion i posiekana

podawanie:





tarty ser

mały pęczek kolendry, posiekanej

WOLNE GOTOWANIE









1 	oliwa z oliwek
1 	fasola jaś
1 	fasolka cannellini
1 	zielony jalapenos
1 	fasola
1 	mielona kolendra
1 	przecier pomidorowy
1 	cukier
2 	pikantny sos pomidorowy
2 	suszone oregano



kwaśna śmietana

Otwórz pokrywę. Dodaj oliwę. Wybierz opcję  w menu, a następnie naciśnij . Dodaj cebulę i czosnek. Gotuj aż cebula zmięknie. Odcedź fasolę i ją dodaj. Odstaw kuskus. Włącz pozostałe składniki. Naciśnij dwukrotnie przycisk , aby zatrzymać. Zamknij pokrywę. Wybierz opcję . Dodaj kuskus, gotuj jeszcze przez 30 minut. Jeśli gotowanie jest skończone, wybierz opcję  w menu i gotuj przez dalsze 20 minut. Podawaj w misce z garścią sera, polane śmietaną i posypane świeżą kolendrą. Klasyczne chili wegetariańskie, bez kuskus.

MAROKAŃSKIE TAGINE Z RYB

RYBY 





2 	czosnek, obrany i posiekany	1	cebula, drobno posiekana
1	czerwona papryka, bez nasion i posiekana	2 	seler naciowy, posiekany
2	krojone pomidory	1 	zmielony kminek
1 	mielony imbir	1 	kurkuma
1	laska cynamonu	1 	pasta harissa
120 ml	białe wino	1 	przecier pomidorowy
120 ml	bulion rybny	1	cytryna
675 g	ryba (dorsz/karmazyn/łososia)	1 	zielone oliwki
1	mały pęczek kolendry, posiekanej		sól i pieprz

Odstaw kolendrę. Otwórz pokrywę. Włącz pozostałe składniki. Zamknij pokrywę. Wybierz opcję  w menu, a następnie naciśnij . Gotuj, aż ryba zacznie się rozpadać (40-60 minut). Naciśnij dwukrotnie przycisk , aby zatrzymać. Dodaj kolendrę. Przypraw i podawaj. Wspaniale smakuje z kuskusem.

GROCHÓWKA Z GOLONKĄ

WOLNE GOTOWANIE 

1150 ml	kostka rosółowa z kurczaka	1	cebula, drobno posiekana
225 g	groch	1	marchew, drobno pokrojona
1 	seler naciowy, posiekany	2 	czosnek (zgnieciony)
1 	tymianek, drobno posiekany	1 	liść laurowy
1	golonka		czarny pieprz







Otwórz pokrywę. Dodaj bulion. Wybierz opcję  w menu, a następnie naciśnij . Doprowadź do wrzenia, ciągle mieszając. Gotuj na wolnym ogniu przez 10 minut. Włącz pozostałe składniki. Naciśnij dwukrotnie przycisk , aby zatrzymać. Zamknij pokrywę. Wybierz opcję . Poczekaj, aż program się skończy. Wyjmij golonkę. Zdejmij skórę i wyjmij kości. Pokrój mięso w kostkę. Wyjmij liście laurowe. Ugnieć groch drewnianą łyżką. Dodaj mięso. Przypraw i podawaj.

Niebo w gębie!

IRLANDZKI GULASZ (STEW) Z PIEROŻKAMI Z KOZIM SEREM

DUSZENIE 





na gulasz:

1.8 kg	łopatka jagnięca (ugotowana)	1 	oliwa z oliwek
250 g	wędzony boczek	3 	czosnek (zgnieciony)
950 ml	bulion z jagnięciny		sól i pieprz
1	duża cebula, drobno posiekana	2	marchew, drobno pokrojona
2 	seler naciowy, posiekany	2 	rozmaryn, posiekany
2 	przecier pomidorowy	1 	mąka kukurydziana

na pierożki:

100 g	mąka samo-rosnąca	1 	proszek do pieczenia
50 g	tłuszcz barani	1 	sól
75 ml	woda	1 	suszona pietruszka
40 g	ser kozii (miękkiej)	1 	suszony tymianek
1 	suszony majeranek	1 	czarny pieprz

na gulasz:

Zdejmij mięso z kości. Pokrój mięso i boczec na nieduże kawałki. Otwórz pokrywę. Wybierz opcję  w menu, a następnie naciśnij . Dodaj bulion. Doprowadź do wrzenia, ciągle mieszając. Gotuj na wolnym ogniu przez 10 minut. Przelej bulion do dzbanka. Dodaj oliwę. Dodaj cebulę i duś do miękkości. Dodaj mięso, czosnek, zioła i inne warzywa i gotuj przez 5 minut. Dodaj bulion. Dodaj przecier pomidorowy. Naciśnij dwukrotnie przycisk , aby zatrzymać. Zamknij pokrywę. Wybierz opcję .

na pierożki:

Wymieszaj wszystkie składniki. Podziel masę na 6 kulek. Pozostaw na 20 minuty.







na zakończenie:







W kubku zrób gładkie ciasto z mąki kukurydzianej i odrobiny wody. 30 minut przed końcu gotowania, otwórz pokrywę. Wmieszaj ciasto do gulaszu. Dodaj pierożki. Zamknij pokrywę. Poczekaj, aż program się skończy i podawaj. Wspaniały półmisek ze smacznym daniem!





Jeśli nie masz mięsa jagnięcego gotowanego, możesz zastosować jagnięcinę surową w programie wolnego gotowania, zamiast w programie duszenia. Potem kontynuuj od pierożków.

OGNISTE CHILI Z WOŁOWINY NOWOJORSKIEJ

DUSZENIE

- 450 g duszona wołowina
- 3  czosnek, obrany i posiekany
- 2  zmielony kminek
- 1  pieprz cayenne
- 1  wędzona papryka/Chipotle w proszku
- 1 zielony pieprz
- 1  sól
- 1  liście bazylii, grubo posiekane

- 1  oliwa z oliwek
- 2 cebula, drobno posiekana
- 2  chilli w proszku
- 2  sos pomidorowy
- 2  pomidory
- 1  liść laurowy
- 1  czarny pieprz
- 1  fasola

Otwórz pokrywę. Dodaj oliwę. Wybierz opcję  w menu, a następnie naciśnij . Posiekaj wołowinę, pomidory i paprykę na kawałki wielkości kęsów. Zrumień mięso i je wyjmij. Dodaj cebulę, czosnek i wszystkie przyprawy. Gotuj aż cebula zmięknie. Dodaj mięso. Odstaw fasolę. Włącz pozostałe składniki. Naciśnij dwukrotnie przycisk , aby zatrzymać. Zamknij pokrywę. Wybierz opcję . Dodaj fasolę i gotuj jeszcze przez 30 minut. Jeśli pod koniec programu mięso jest jeszcze trochę twarde, dolej wody i uruchom program mięsa na 30 minut.

JOGURT DOMOWEJ ROBOTY

JOGURT





1200 ml mleko

100 ml jogurt

opcja smakowa

50 g Latem mrożona mieszanka jagód



1  miód



Otwórz pokrywę. Wlej mleko. Wybierz opcję  w menu, a następnie naciśnij . Niech mleko się podgrzeje do chwili, gdy zaczną tworzyć się bańki na krawędziach. Naciśnij dwukrotnie przycisk , aby zatrzymać. Ostudź mleko do temperatury między 37°C a 45°C. Wmieszaj jogurt w mleko. Musisz dokładnie wmieszać, inaczej jogurt będzie grudkowaty. Zamknij pokrywę. Wybierz opcję  w menu, a następnie naciśnij . Poczekaj, aż program się skończy. Wstaw jogurt do lodówki celem schłodzenia. Jagody delikatnie podgrzej na patelni. Dodaj miód. Gdy owoce zaczną pękać, zdejmij z ognia, ostudź, a następnie wymieszaj z jogurtem. Jeśli chcesz przechować jogurt, najpierw należy wysterylizować słoiki do jogurtu. Ogrzewać je w piecu w temperaturze 100°C przez 10 minut. Jogurt można przechowywać w lodówce do 2 tygodni.



PL

ŁOSOŚ NATARTY PRZYPRAWAMI

RYBY

- 2 filety z łososia (ze skórą)
- 1  papryka
- ½  zmielony kminek
- 1  jasnobrązowy cukier





- 1  oliwa z oliwek
- 1  chilli w proszku
- 1  sól i pieprz
- 1 cytryna



Wymieszaj paprykę, chili w proszku, kminek, cukier, sól i pieprz. Posyp na filety z łososia. Otwórz pokrywę. Dodaj oliwę. Wybierz opcję  w menu, a następnie naciśnij . Odczekaj kilka minut, aż oliwa będzie gorąca. Włóż filety skórą w dół. Zamknij pokrywę. Dzięki doskonałemu połączeniu gotowania na parze i smażenia kawałków ryb, otrzymujemy chrupiącą skórę. Podawaj z plasterkiem cytryny. Bardzo lekkie danie.

PUDDING NASĄCZANY SYROPEM

PARA

- 115 g masło
- 100 g cukier puder
- 175 g mąka samo-rośnąca
- 4  złoty syrop



- 2  
- ¼  esencja waniliowa
- 2  mleko





Wbij jajka do miski. W misce utrzyj masło i cukier. Stopniowo dodawaj jajka, następnie wanilię i mąkę. Wlej wino i mieszaj. Nasmaruj naczynie żaroodporne 1200ml. Wlej syrop na dół naczynia żaroodpornego, a na wierzchu ułóż ubitą mieszaninę. Przykryj papierem do pieczenia a następnie folią aluminiową i zawiąż na górze za pomocą sznurka. Otwórz pokrywę. Wstaw naczynie żaroodporną w miskę urządzenia. Wlej do miski tyle wrzącej wody, aby doszła na 3 cm poniżej górnej części naczynia żaroodpornego. Zamknij pokrywę. Wybierz opcję  w menu. Ustaw czas pieczenia na 1 godzinę 30 minut. Naciśnij przycisk . Poczekaj, aż program się skończy. Przewróć na półmisek i podawaj ciepły. Znacomity pudding na każdą porę roku!!

JASNY CHLEB

CHLEB

1  złoty syrop
320 ml mleko
500 g mąka pszenna typ 600-650



1  masło
1  suszone drożdże
1  sól

Otwórz pokrywę. Dodaj mleko. Wybierz opcję  w menu, a następnie naciśnij . Niech mleko się podgrzeje do chwili, gdy zaczną tworzyć się bańki na krawędziach. Wlej mleko do dzbanka. Naciśnij dwukrotnie przycisk , aby zatrzymać. Ostudź mleko do temperatury między 37°C a 45°C. Roztopić masło na patelni na małym ogniu. Przesiej mąkę i sól do miski. Dodaj drożdże, masło, syrop cukrowy. Dodaj mleko i zagniataj ciasto w kulę. Jeżeli ciasto jest zbyt rzadkie, dodaj trochę mąki. Przykryj i pozostaw w ciepłym miejscu na 10 minut. Ponownie zagnieć. Przykryj i pozostaw w ciepłym miejscu na 10 minut. Otwórz pokrywę. Wybierz opcję  w menu, a następnie naciśnij . Zamknij pokrywę. 30 minut przed końcu gotowania, otwórz pokrywę. Obróć chleb. Spowoduje to, że chleb na wierzchu się ubrzązowi i będzie mieć kruchą skórkę. Poczekaj, aż program się skończy. Podawaj posmarowany masłem.

CIASTO CZEKOLADOWE BROWNIE



CIASTO

170 g masło niesolone
340 g cukier
170 g kakao w proszku
110 g dropsy z mlecznej czekolady

3 
1  esencja waniliowa
1  sól
75 g mąka pszenna

podawanie:



lody waniliowe (opcja)

Roztopić masło na patelni na małym ogniu. Wylóż miskę folią posmarowaną masłem. Ubij w naczyniu roztopione masło, cukier, kakao w proszku, mąkę, jaja, wanilię i sól. Wymieszaj razem z czekoladą. Wlóż ciasto w folię wewnątrz miski. Zamknij pokrywę. Wybierz opcję  w menu. Ustaw czas pieczenia na 1 godzinę 30 minut. Naciśnij przycisk . Ciasto powinno być twarde na krawędziach i lekko lepzące się w środku. Ciasto podawaj ciepłe, zwieńczone lodami.

KARCZOCHY GOTOWANE NA PARZE



PARA



1  czosnek, obrany i posiekany
2 karczochy
gałązki ziół (estragon, mięta, pietruszka, tymianek)
1 cytryna

Pokrój cytrynę w plasterki. Równo odetnij rdzenie w dolnej części każdego karczocha. Odetnij górną ćwiartkę każdego karczocha. Wyrzuć wszystkie uszkodzone liście. Przetrzyj powierzchnie cięcia plasterkiem cytryny. Ułóż plasterki cytryny w koszu. Dodaj po gałązce świeżych ziół. Dodaj czosnek. Połóż karczocha na górze. Napełnij wodą do poziomu 2 na lewej podziałce, wewnątrz miski. Kosz przykryj pokrywą Zamknij pokrywę. Wybierz opcję  w menu, a następnie naciśnij . Karczochy są ugotowane, gdy zewnętrzne liście łatwo odchodzą. Podawaj ciepłe lub zimne w winegret. Niesamowite!

JEDNODANIOWY JĘCZMIEŃ PERŁOWY I FASOLA BORLOTTI





DUSZENIE

1  oliwa z oliwek
175 g jęczmień perłowy
1  krojone pomidory
1000 ml wywar z warzyw
125 ml wytrawne czerwone wino

1  fasola borlotti
1 cebula, drobno posiekana
1  przecier pomidorowy
2  pietruszka (posiekana)
sól i pieprz

podawanie:



olej z ostrego chili (opcja)

Otwórz pokrywę. Wybierz opcję  w menu, a następnie naciśnij . Dodaj bulion. Doprowadź do wrzenia, ciągle mieszając. Gotuj na wolnym ogniu przez 10 minut. Przelej bulion do dzbanka. Dodaj oliwę. Dodaj cebulę i duś do miękkości. Wlej wino i gotuj przez kilka minut. Dodaj jęczmień perłowy i mieszaj, aż uzyska kolor wina. Odcedź fasolę i ją dodaj. Dodaj pomidory. Dodaj bulion. Naciśnij dwukrotnie przycisk , aby zatrzymać. Zamknij pokrywę. Wybierz opcję . 30 minut przed końce gotowania, otwórz pokrywę. Sprawdź ilość płynu zebranego w misce. W razie potrzeby dodaj 150 ml gorącej wody. Zamknij pokrywę. Poczekaj, aż program się skończy. Podawaj ze świeżym chrupkim chlebem i spryskaj olejem z ostrego chili.

CHLEB SODOWY

CHLEB

1  mieszanka chleba sodowego
350 ml woda

Otwórz pokrywę. Posmaruj miskę masłem. Wybierz opcję  w menu. Zamknij pokrywę. Ustaw czas pieczenia na 2 godziny 15 minut. Naciśnij przycisk . Pozostaw do ostygnięcia. Mieszanke chleba sodowego włóż do miski. Dodaj wodę. Wymieszaj ręcznie w kulę. Otwórz pokrywę. Przełóż ciasto do miski. Podziel ciasto na ćwiartki za pomocą plastikowej szpachelki. Zamknij pokrywę. 30 minut przed końce gotowania, otwórz pokrywę. Obróć chleb. Spowoduje to, że chleb na wierzchu się ubrązowi i będzie mieć kruchą skórkę. Poczekaj, aż program się skończy. Ostudź na stojaku z drutu. Podawaj z solonym masłem sam lub do posiłku.

PORRIDGE (OWSIANKA)

OWSIANKA/RISOTTO



2  owsianka
1/4  sól

woda
2  cukier

podawanie:



ciemny brązowy cukier

mleko / śmietanka

Otwórz pokrywę. Dodaj płatki owsiane, sól oraz cukier. Napełnij wodą do poziomu 1 1/2 na prawej podziałce, wewnątrz miski. Zamknij pokrywę. Wybierz opcję  w menu, a następnie naciśnij . Poczekaj, aż program się skończy. Podawaj z mlekiem lub śmietaną. Posyp ciemno-brązowym cukrem. Jeśli zechcesz, na 15 minut przed końcem gotowania możesz dodać posiekane suszone morele i połówki śliwek (bez pestek). Porridge można przechować w lodówce do 2 dni, po wyjęciu podgrzać.

PORRIDGE O SMAKU ORZECHOWYM

OWSIANKA/RISOTTO



1/2  płatki owsiane
120 ml mleko
1  mielony cynamon

woda
3  wiórki kokosowe

podawanie:

złoty syrop



posiekane migdały

Otwórz pokrywę. Dodaj płatki owsiane, cynamon, wiórki kokosowe i mleko. Napełnij wodą do poziomu 1/2 na prawej podziałce, wewnątrz miski. Zamknij pokrywę. Wybierz opcję  w menu, a następnie naciśnij . Poczekaj, aż program się skończy. Skrop je złotym syropem i posyp migdałami.

RISOTTO Z BURAKIEM CÍWIKŁOWYM Z MULTICOOKERA

OWSIANKA/ RISOTTO

400 g burak ćwikłowy
250 g ryż arbori/risotto
250 ml białe wino
900 ml wywar z warzyw / kostka rosółowa z kurczaka





2  oliwa z oliwek
1 cebula, drobno posiekana
2  czosnek, obrany i posiekany
1  tymianek, drobno posiekany

na zakończenie:

100 ml jogurt
1  masło







1  pietruszka (posiekana)



PL

Otwórz pokrywę. Wybierz opcję  w menu, a następnie naciśnij . Dodaj bulion. Doprowadź do wrzenia, ciągle mieszając. Gotuj na wolnym ogniu przez 10 minut. Przelej bulion do dzbanka. Naciśnij dwukrotnie przycisk , aby zatrzymać. Wybierz opcję  w menu, a następnie naciśnij . Pozostaw do ostygnięcia. Obierz buraki i pokrój na 1 cm kostki. Włóż buraki, czosnek i cebulę w miskę. Gotuj aż cebula zmięknie. Wmieszaj ryż. Zamknij pokrywę i gotuj przez 3-4 minut. Otwórz pokrywę. Wlej wino i mieszaj. Zamknij pokrywę i gotuj przez 3-4 minut. Otwórz pokrywę. Dodaj tymianek. Dodaj bulion. Zamknij pokrywę. Poczekaj, aż program się skończy. Sprawdź ryż - powinien być akurat, nie twardy. Jeśli ryż nie jest gotowy, dodaj trochę wody i gotuj przez następne kilka minut. Wmieszaj masło - to dodaje risotto blasku. Podawaj z odrobiną jogurtu i posyp pietruszką. Znakomicie nadaje się na przystawkę lub lekki lunch.

KURCZAK Z POMIDORAMI I GRZYBAMI



MIĘSO 



2	piersi z kurczaka bez kości i skóry	1 	oliwa z oliwek
450 g	pieczarki brunatne, posiekane	1 	krojone pomidory
2 	czosnek, obrany i posiekany	1 	sos pomidorowy
1 	sos Worcestershire	1 	suszone oregano
	sól i pieprz		

Otwórz pokrywę. Wybierz opcję  w menu, a następnie naciśnij . Dodaj oliwę. Posmaruj piersi kurczaka solą i pieprzem i włóż je do miski. Posmaruj mięso po drugiej stronie. Dodaj czosnek i pieczarki. Piecz przez 3-4 minut, obracając kurczaka. Dodaj pomidory, sos Worcestershire, sos pomidorowy i oregano. Dalej piecz, obracając kurczaka. Sprawdź, czy kurczak jest upieczony. Podawaj z makaronem, ziemniakami lub ryżem. Szybkie i smaczne danie gotowe.

PEKLOWANE ŻEBERKA Z SYROPEM KLONOWYM I SOJĄ





MIĘSO 

1 kg	żeberka wieprzowe	1	cebula, drobno posiekana
350 ml	Guinness / stout	1 	oliwa z oliwek
140 ml	bulion wołowy / bulion wieprzowy	3 	czosnek, obrany i posiekany
60 ml	syrop klonowy / miód	2 	ciemny sos sojowy

Otwórz pokrywę. Wybierz opcję  w menu. Dodaj oliwę. Ustaw czas pieczenia na 1 godzinę 45 minut. Naciśnij przycisk . Dodać żeberka i zrumieniać przez 5 minut - obracając od czasu do czasu. Wyjąć żeberka. Dodaj cebulę i czosnek. Gotuj aż cebula zmięknie. Z powrotem włożyć żeberka do miski. Wymieszać Guinness, bulion, syrop klonowy i sos sojowy. Zamknij pokrywę. Poczekaj, aż program się skończy. Przypraw i podawaj. Świetna przystawka i danie mieszanego lunchu.





AROMATYCZNY RYŻ





RYŻ 

2 	ryż		woda
1	kostka (warzywa)	2	marchew, drobno pokrojona
1	czerwona papryka, bez nasion i posiekana	2 	seler naciowy, posiekany
1 	kurkuma	1 	groszek (opcja)



Otwórz pokrywę. Włóż ryż do miski. Napełnij wodą do poziomu 2 na lewej podziałce, wewnątrz miski. Rozdrobnij kostkę rosółową i wymieszaj w wodzie. Włącz pozostałe składniki. Zamknij pokrywę. Wybierz opcję . Poczekaj, aż program się skończy i podawaj. Jeśli ryż nie jest jeszcze gotowy, pozostaw na kilka minut pod zamkniętą pokrywą, aby doszedł w parze.





ZUPA POMIDOROWA ZUPA

1	cebula, drobno posiekana	1 	oliwa z oliwek
1 	krojone pomidory	2	krojone pomidory
1	czerwona papryka, bez nasion i posiekana	2	ziemniaki
550 ml	kostka rosółowa z kurczaka	1 	przecier pomidorowy
1 	suszone zioła	1 	czarny pieprz







Otwórz pokrywę. Dodaj bulion. Wybierz opcję  w menu, a następnie naciśnij . Doprowadź do wrzenia, ciągle mieszając. Gotuj na wolnym ogniu przez 10 minut. Przelej bulion do dzbanka. Naciśnij dwukrotnie przycisk , aby zatrzymać. Obierz ziemniaki i pokrój. Wybierz opcję  w menu, a następnie naciśnij . Dodaj oliwę. Dodaj cebulę i słodką paprykę. Gotuj aż cebula zmięknie. Dodaj bulion. Włącz pozostałe składniki. Zamknij pokrywę. Poczekaj, aż program się skończy. Przypraw. Podawaj z chrupkim chlebem.





SZPONDER JEDNODANIOWY

1 kg	szponder
2 	czosnek, obrany i posiekany
50 g	kiełbasa chorizo pokrojona w plasterki
2	czerwona cebula, drobno posiekana
600 ml	bulion wołowy
2 	suszone zioła
6-8	ziemniaki (małe)
2 	sos Worcestershire





Na ziemniakach pozostaw łupiny. Pokrój na kawałki ziemniaki, marchew i seler. Nasmaruj szponder solą i pieprzem. Otwórz pokrywę. Wybierz opcję  w menu, a następnie naciśnij . Dodaj bulion. Doprowadź do wrzenia, ciągle mieszając. Gotuj na wolnym ogniu przez 10 minut. Przelej bulion do dzbanka. Podsmaż chorizo w małej ilości tłuszczu przez 2 minuty. Dodaj mięso. Zrumieniąj cały szponder. Dodaj cebulę, czosnek, ziemniaki, seler i marchew. Jeśli masz do wykorzystania jakieś inne warzywa korzeniowe, dodaj je również. Gotuj aż cebula zmięknie. Dodaj bulion. Włącz pozostałe składniki. Naciśnij dwukrotnie przycisk , aby zatrzymać. Wybierz opcję . Poczekaj, aż program się skończy i podawaj. Gotowanie przez 8 godzin nie zaszkodzi, ale danie będzie prawdopodobnie gotowe do jedzenia po 5 godzinach.

ZUPA Z KIEŁBASY CHORIZO, KAPUSTY I JABŁEK

1/4	kiełbasa chorizo, drobno posiekana	1	cebula, drobno posiekana
1	jabłko	2	marchew, drobno pokrojona
2 	seler naciowy, posiekany	2	krojone pomidory
1/4	wiosenna kapusta, drobno szatkowana	1 	przecier pomidorowy
2 	czosnek, obrany i posiekany	1 	pieprz cayenne
1 	sól	1 	czarny pieprz
850 ml	wywar z warzyw		

Otwórz pokrywę. Wybierz opcję  w menu, a następnie naciśnij . Podsmaż chorizo w małej ilości tłuszczu przez 2 minuty. Dodaj cebulę i czosnek. Gotuj aż cebula zmięknie. Obierz i posiekaj jabłko. Włącz pozostałe składniki. Naciśnij dwukrotnie przycisk , aby zatrzymać. Zamknij pokrywę. Wybierz opcję  w menu, a następnie naciśnij . Poczekaj, aż program się skończy. Wspaniała zupa. Jeszcze lepiej smakuje, jeśli pozostanie na noc w lodówce, zyska na smaku.

WOLNE GOTOWANIE

2 	przecier pomidorowy
2 	liść laurowy
2	marchew
3 	seler zwyczajny
2 	rozmaryn, posiekany
1 	krojone pomidory
	sól i pieprz

ZUPA



PL

Pročitajte upute, držite ih na sigurnom mjestu, prosljedite ih ako dajete uređaj. Uklonite cijelo pakiranje prije uporabe.

VAŽNE SIGURNOSNE MJERE

Poštujte osnovne sigurnosne mjere, uključujući slijedeće:

Ovaj uređaj mogu koristiti djeca od 8 godina pa na više i osobe smanjenih tjelesnih, osjetilnih ili mentalnih sposobnosti ili osobe koje ne raspolažu iskustvom i znanjem ako su pod nadzorom ili rade po uputama, te razumiju uključene opasnosti. Djeca se ne smiju igrati s uređajem. Čišćenje i održavanje ne smiju vršiti djeca ako nisu starija od 8 godina i moraju biti pod nadzorom. Držite uređaj i kabel van dosega djece mlađe od 8 godina. Ako su konektor ili kabel oštećeni, moraju se zamijeniti specijalnim sklopom koji je dostupan kod proizvođača ili njegovog ovlaštenog servisera.

-  Nemojte koristiti ovaj uređaj u blizini kada, tuševa, umivaonika ili drugih posuda s vodom.
-  Pogrešna uporaba aparata može uzrokovati ozljedu.
-  Površine uređaja će postati vruće. Preostala toplina održavat će površine toplim nakon uporabe.
 - Nemojte stavljati zamrznuto meso ili perad u uređaj; odmrznite ga potpuno prije uporabe.
 - Kuhajte meso, perad i prerađevine (mljeveno meso, hamburgere, itd) dok se iz njih ne pojavi bistri sok. Kuhajte ribu dok joj boja ne postane potpuno mutna.
 - Nemojte pokušavati da kuhate bilo šta u tijelu kuhala; kuhajte samo u odvojivoj posudi.
 - Nemojte ju napuniti preko oznake max.
 - Nemojte stavljati poklopac ili neki drugi predmet na uređaj.
 - Izvucite utikač iz električne utičnice, potom izvucite konektor iz izlaznog priključka uređaja.
 - Iskopčajte uređaj iz utičnice kad nije u uporabi.
 - Nemojte koristiti dijelove ili dodatke drugih proizvođača.
 - Nemojte koristiti uređaj u bilo koje druge svrhe osim onih opisanih u ovim uputama.
 - Nemojte koristiti uređaj ako je oštećen ili neispravan.

ISKLUČIVO ZA KUĆNU UPORABU

CRTEŽI



- | | |
|-----------------------|-------------|
| 1. Upravljačka ploča | 5. Mjerica |
| 2. Poklopac | 6. Košara |
| 3. Zapor poklopca | 7. Posuda |
| 4. Unutarnji poklopac | 8. Konektor |

PRIPREMA:



1. Postavite uređaj na stabilnu, ravnu površinu, otpornu na toplinu.
2. Nemojte postavljati uređaj u blizini zavjesa, ispod policca, ormarića ili blizu bilo čega što se može oštetiti izlaznom parom.
3. Držite rukavice za pećnicu pri ruci, kao i podlošku otpornu na toplinu ili ploču na koju ćete postaviti posudu poslije kuhanja.

4. Stavite posudu u kuhalo.
5. Okrenite posudu na četvrtinu okreta u oba pravca, kako biste bili sigurni da dno posude ima dobar kontakt s elementom.



RIŽA

1. Koristite mjericu za stavljanje riže u posudu.
2. Nemojte koristiti više od 10 mjerica riže.
3. Koristite ljestvicu baždarenu od 2 do 10, koja se nalazi s lijeve strane unutar posude.
4. Napunite posudu vodom do broja koji odgovara broju mjerica riže.
5. Zatvorite poklopac.
6. Pritisnite  gumb. Gumb će zasvijetliti.
7. Vanjski će dijelovi displaya treperiti tijekom zagrijavanja hrane.
8. Zatim će se na displayu prikazati preostalo vrijeme kuhanja (13 minuta) i odbrojavanje.
9. Na kraju postupka kuhanja, uređaj će se prebaciti u način „održavanje toplim“.
10. Indikatorsko svjetlo  će se upaliti.
11. Otvorite poklopac.
12. Podignite posudu i postavite je na podlošku otpornu na toplinu ili ploču.
13. Pritisnite  gumb.
14. Uz pomoć lopatice promiješajte rižu kako bi para izašla van.
15. Ponekad će se na sloju riže koji je u kontaktu sa zdjelom pojaviti korica.
16. Ako je ne želite, možete je skinuti uz pomoć lopatice, pošto ste poslušili rižu.

SPORO KUHANJE

1. Popecite meso i povrće (vidi „POPEĆI/POPRŽITI/OMEKŠATI/PROKUHATI“).
2. Prokuhajte tekućinu za kuhanje (vidi „POPEĆI/POPRŽITI/OMEKŠATI/PROKUHATI“).
3. Stavite čvrste sastojke u posudu, zatim dodajte tekućinu za kuhanje.
4. Zatvorite poklopac.
5. Pritisnite  gumb. Gumb će zasvijetliti.
6. Na displayu će se prikazati 8 sati i započet će odbrojavanje.
7. Nakon isteka vremena kuhanja, uređaj će se prebaciti u način „održavanje toplim“.
8. Indikatorsko svjetlo  će se upaliti.
9. Pritisnite  gumb. Otvorite poklopac. Izvadite hranu.





PRAVLJENJE GULAŠA

1. Popecite meso i povrće (vidi „POPEĆI/POPRŽITI/OMEKŠATI/PROKUHATI“).
2. Prokuhajte tekućinu za kuhanje (vidi „POPEĆI/POPRŽITI/OMEKŠATI/PROKUHATI“).
3. Stavite čvrste sastojke u posudu, zatim dodajte tekućinu za kuhanje.
4. Zatvorite poklopac.
5. Pritisnite  gumb. Gumb će zasvijetliti.
6. Na displayu će se prikazati 1 sat i započet će odbrojavanje.
7. Na kraju postupka kuhanja, uređaj će se prebaciti u način „održavanje toplim“.
8. Indikatorsko svjetlo  će se upaliti.
9. Pritisnite  gumb. Otvorite poklopac. Izvadite hranu.





MESO

1. Hranu sa svih strana premažite jestivim uljem.
2. Utrljajte začine po površini hrane.
3. Stavite žlicu jestivog ulja u posudu.
4. Stavite hranu u posudu.
5. Zatvorite poklopac.
6. Vrijeme ovisi o veličini hrane.
7. Nemojte kuhati više od otprilike 500 g hrane u isto vrijeme.



8. Preporučujemo vrijeme kuhanja od 10 minuta + 10 minuta po 100 g težine za govedinu.
9. Nemojte kuhati svinjetinu ili perad manje od 5, 10, 15, 20, 25, 30 minuta.
10. Koristite gumb  za odabir  u izborniku.
11. Odaberite vrijeme kuhanja. Zadano vrijeme je 20 minuta.
12. Gumb h i min možete koristiti samo kada treperi vrijeme prikazano na displayu.
13. Koristite gumb min za kretanje kroz mogućnosti displaya (10, 15, 20, 25, 5, 10, 15, 20, 25, 30, 35, 40, 45, 50 i 55).
14. Ako želite kuhati za 1 sat, pritisnite gumb h.
15. Za poništavanje postavke od 1 sat, ponovno pritisnite gumb h dok na displayu treperi vrijeme.
 - Ako uređaj ne koristite duže od 2 minute, isti će se prebaciti u stanje čekanja.
16. Kada ste postavili vrijeme, pritisnite .
17. Na displayu će otpočeti odbrojavanje.
18. Na kraju postupka kuhanja, uređaj će se prebaciti u način „održavanje toplim“.
19. Indikatorsko svjetlo  će se upaliti.
20. Pritisnite  gumb. Otvorite poklopac. Izvadite hranu.

JUHA

1. Poperite meso i povrće (vidi „POPEĆI/POPRŽITI/OMEKŠATI/PROKUHATI“).
2. Stavite čvrste sastojke u posudu, zatim dodajte tekućinu za kuhanje.
3. Zatvorite poklopac.
4. Koristite gumb  za odabir  u izborniku.
5. Odaberite vrijeme kuhanja. Zadano vrijeme je 1 sat.
6. Gumb h i min možete koristiti samo kada treperi vrijeme prikazano na displayu.
7. Koristite gumb min za kretanje kroz mogućnosti displaya (10, 15, 20, 25, 5, 10, 15, 20, 25, 30, 35, 40, 45, 50 i 55).
8. Koristite gumb h za kretanje kroz mogućnosti displaya (1, 2, 3, 4 i 5).
9. Za poništavanje postavke od 5 sat, ponovno pritisnite gumb h dok na displayu treperi vrijeme.
 - Ako uređaj ne koristite duže od 2 minute, isti će se prebaciti u stanje čekanja.
10. Kod ovog programa imate mogućnost korištenja tajmera (vidi TAJMER).
11. Pritisnite  gumb.
12. Na displayu će otpočeti odbrojavanje.
13. Na kraju postupka kuhanja, uređaj će se prebaciti u način „održavanje toplim“.
14. Indikatorsko svjetlo  će se upaliti.
15. Pritisnite  gumb. Otvorite poklopac. Izvadite hranu.

JOGURT

Jogurtna kultura

Možete koristiti 5, 10, 15, 20, 25, 30 ml (2 žlice):

- Nearomatiziranog jogurta sa živom kulturom – mora biti svjež (tražite onaj s najduljim datumom isteka valjanosti). Različite marke dat će različite rezultate.

Jogurta kojeg ste napravili prethodno.

- Tijekom vremena dolazi do slabljenja bakterija, tako da to možete činiti samo 10 puta prije korištenja druge nove kulture.





Jogurtne kulture u suho-smrznutom stanju koju možete kupiti u ljekarni ili trgovini zdrave hrane.

- Ako se upute na pakiranju kulture razlikuju od ovog vodiča, slijedite upute na pakiranju.





Mlijeko

- Bit će Vam potreban 1 litar mlijeka.
- Punomasno mlijeko dat će gušći jogurt u odnosu na manje masno mlijeko.
- Kako biste ga učinili još gušćim, možete dodati do 8 žlica mlijeka u prahu u tečno mlijeko.
- Isto tako možete koristiti rekonstituirano mlijeko u prahu ili ishlapljeno konzervirano mlijeko.

Pravljenje jogurta

1. Potrebno je uništiti bakterije u mlijeku, da se ne bi suprotstavile bakterijama jogurtne kulture.
2. Dok grijete mlijeko, ostavite da jogurtna kultura dostigne sobnu temperaturu.
3. Otvorite poklopac.
4. Koristite program NA PARI (POPEĆI/POPRŽITI/OMEKŠATI/PROKUHATI) za zagrijavanje mlijeka do razine neposredno ispod točke ključanja.
5. Pustite da se mlijeko ugrije dok se na rubovima ne počnu stvarati mjehurići.
6. Ostavite mlijeko da se ohladi na temperaturi između 37°C i 45°C.
7. Umiješajte jogurtnu kulturu u mlijeko.
8. Moraju biti dobro promiješani, jer će u protivnom jogurt biti grudast.
9. Zatvorite poklopac.
10. Koristite gumb  za odabir  u izborniku.
11. Odaberite vrijeme kuhanja. Zadano vrijeme je 8 sati.
12. Gumbe h i min možete koristiti samo kada treperi vrijeme prikazano na displayu.
13. Koristite gumb min za kretanje kroz mogućnosti displaya (10, 15, 20, 25, 5, 10, 15, 20, 25, 30, 35, 40, 45, 50 i 55).
14. Koristite gumb h za kretanje kroz mogućnosti displaya (6, 7, 8, 9 i 10).
15. Za poništavanje postavke od 10 sat, ponovno pritisnite gumb h dok na displayu treperi vrijeme.
 - Ako uređaj ne koristite duže od 2 minute, isti će se prebaciti u stanje čekanja.
 - Kod ovog programa imate mogućnost korištenja tajmera (vidi TAJMER).
17. Pritisnite  gumb.
18. Na displayu će otpočeti odbrojavanje.
19. Nakon isteka vremena kuhanja, uređaj će se prebaciti u stanje čekanja.
20. To jogurt neće držati toplim.
21. Pritisnite  gumb. Otvorite poklopac. Izvadite hranu.





KRUH

1. Prije uporabe potpuno odmrznite smrznuto tijesto.
2. Nemojte kuhati više od otprilike 500 g hrane u isto vrijeme.
3. Posudu premažite jestivim uljem.
4. Stavite tijesto u posudu.
5. Zatvorite poklopac.
6. Koristite gumb  za odabir  u izborniku.
7. Odaberite vrijeme kuhanja. Zadano vrijeme je 3 sati.
8. Gumbe h i min možete koristiti samo kada treperi vrijeme prikazano na displayu.
9. Koristite gumb min za kretanje kroz mogućnosti displaya (10, 15, 20, 25, 5, 10, 15, 20, 25, 30, 35, 40, 45, 50 i 55).
10. Koristite gumb h za kretanje kroz mogućnosti displaya (1, 2, 3, 4, 5 i 6).
11. Za poništavanje postavke od 6 sat, ponovno pritisnite gumb h dok na displayu treperi vrijeme.
 - Ako uređaj ne koristite duže od 2 minute, isti će se prebaciti u stanje čekanja.
 - Kod ovog programa imate mogućnost korištenja tajmera (vidi TAJMER).
13. Pritisnite  gumb.
14. Na displayu će otpočeti odbrojavanje.
15. Na kraju postupka kuhanja, uređaj će se prebaciti u način „održavanje toplim“.
16. Indikatorsko svjetlo  će se upaliti.
17. Pritisnite  gumb. Otvorite poklopac. Izvadite hranu.



RIBA

1. Hranu sa svih strana premažite jestivim uljem.
2. Utrljajte začine po površini hrane.
3. Stavite žlicu jestivog ulja u posudu.
4. Stavite hranu u posudu.
5. Zatvorite poklopac.





6. Vrijeme ovisi o veličini hrane.
7. Nemojte kuhati više od otprilike 500 g hrane u isto vrijeme.
8. Preporučujemo vrijeme kuhanja od 10 minuta po 100 g težine.
9. Koristite gumb  za odabir  u izborniku.
10. Odaberite vrijeme kuhanja. Zadano vrijeme je 20 minuta.
11. Gumb h i min možete koristiti samo kada treperi vrijeme prikazano na displayu.
12. Koristite gumb min za kretanje kroz mogućnosti displaya (10, 15, 20, 25, 5, 10, 15, 20, 25, 30, 35, 40, 45, 50 i 55).
13. Ako želite kuhati za 1 sat, pritisnite gumb h.
14. Za poništavanje postavke od 1 sat, ponovno pritisnite gumb h dok na displayu treperi vrijeme.
 - Ako uređaj ne koristite duže od 2 minute, isti će se prebaciti u stanje čekanja.
15. Kada ste postavili vrijeme, pritisnite .
16. Na displayu će otpočeti odbrojavanje.
17. Na kraju postupka kuhanja, uređaj će se prebaciti u način „održavanje toplim“.
18. Indikatorsko svjetlo  će se upaliti.
19. Najbolje je izvaditi hranu čim se skuha kako se ne bi osušila.
20. Pritisnite  gumb. Otvorite poklopac. Izvadite hranu.

NA PARI (STEAMING)

1. Posudu napunite hladnom vodom do oznake 6.
2. Stavite košaru na vrh posude i stavite hranu u košaru.
3. Za ravnomjerno kuhanje, izrežite sve komade hrane otprilike na istu veličinu.
4. Ukoliko kuhate grašak ili bilo šta što može prsnuti ili upasti u vodu, napravite paketić od aluminijske folije.
5. Budite pažljivi kod skidanja paketića: stavite rukavice za pećnicu i koristite se plastičnim hvataljkama/žlicama.
6. Zatvorite poklopac.
7. Koristite gumb  za odabir  u izborniku.
8. Odaberite vrijeme kuhanja. Zadano vrijeme je 30 minuta.
 - Sljedeće bi trebalo kuhati unutar zadanog vremena:

Hrana (svježa)	Količina
Mahune	200g
Prokulice	200g
Mrkve (rezane)	200g
Krumpiri (rezani)	400g
Brokule	200g
Kupus	Četvrt
Klipovi kukuruza	2

9. Gumb h i min možete koristiti samo kada treperi vrijeme prikazano na displayu.
10. Koristite gumb min za kretanje kroz mogućnosti displaya (5, 10, 15, 20, 25, 30, 35, 40, 45, 50 i 55).
11. Koristite gumb h za kretanje kroz mogućnosti displaya (1 i 2).
12. Za poništavanje postavke od 2 sat, ponovno pritisnite gumb h dok na displayu treperi vrijeme.
 - Ako uređaj ne koristite duže od 2 minute, isti će se prebaciti u stanje čekanja.
13. Kod ovog programa imate mogućnost korištenja tajmera (vidi TAJMER).
14. Pritisnite  gumb.
15. Na displayu će otpočeti odbrojavanje.
16. Na kraju postupka kuhanja, uređaj će se prebaciti u način „održavanje toplim“.
17. Indikatorsko svjetlo  će se upaliti.

18. Najbolje je izvaditi hranu čim se skuha kako ne bi postala gnjecava.
19. Pritisnite  gumb. Otvorite poklopac. Izvadite hranu.

POPEĆI/POPRŽITI/OMEKŠATI/PROKUHATI (BROWN/SAUTE/SOFTEN/BOIL)

- Program NA PARI  (STEAMING) možete koristiti s njegovim zadanim postavkama, što podrazumijeva kuhanje u tavi za visoku temperaturu s otvorenim poklopcem u trajanju od 5, 10, 15, 20, 25, 30 minuta, prije korištenja nekog drugog programa.
- Koristite s malo ulja za popeći ili popržiti meso i povrće, omekšati luk, celer, poriluk itd.
- Koristite s vodom ili temeljcem za podgrijavanje tekućine za kuhanje.
- Kada se prebacite na glavni program, uređaj se zagrijava pod pretpostavkom da su neki ili svi sastojci već u posudi.
- Tada ne morate prati tavu koju biste koristili tijekom pripreme.





PORRIDGE (ZOBENA KAŠA) / RIŽOTO

Koristite mjericu za stavljanje žitarica (riža, zob, ječam itd.) u posudu.

Porridge (zobena kaša)

- Koristite ljestvicu baždarenu od ½ do 1½, koja se nalazi s desne strane unutar posude.
- Nemojte ju napuniti preko oznake **max**.



Congee (kaša od riže)

- Koristite ljestvicu baždarenu od 1 do 3, koja se nalazi po sredini unutar posude.
 - Nemojte ju napuniti preko oznake **max**.
1. Napunite posudu vodom do broja koji odgovara broju mjerica žitarice.
 2. Zatvorite poklopac.
 3. Koristite gumb  za odabir  u izborniku.
 4. Odaberite vrijeme kuhanja. Zadano vrijeme je 1 sat.
 5. Gumb h i min možete koristiti samo kada treperi vrijeme prikazano na displayu.
 6. Koristite gumb min za kretanje kroz mogućnosti displaya (5, 10, 15, 20, 25, 30, 35, 40, 45, 50 i 55).
 7. Koristite gumb h za kretanje kroz mogućnosti displaya (1, 2, 3 i 4).
 8. Za poništavanje postavke od 4 sat, ponovno pritisnite gumb h dok na displayu treperi vrijeme.
 - Ako uređaj ne koristite duže od 2 minute, isti će se prebaciti u stanje čekanja.
 9. Kod ovog programa imate mogućnost korištenja tajmera (vidi TAJMER).
 10. Pritisnite  gumb.
 11. Na displayu će otpočeti odbrojanje.
 12. Na kraju postupka kuhanja, uređaj će se prebaciti u način „održavanje toplim“.
 13. Indikatorsko svjetlo  će se upaliti.
 14. Pritisnite  gumb. Otvorite poklopac. Izvadite hranu.



Rižoto

Slijedite upute u receptu prikazanom u nastavku ove knjižice.



KOLAČ

1. Prije uporabe potpuno odmrznite smrznuto tijesto.
2. Nemojte puniti posudu više od polovice.
3. Posudu premažite jestivim uljem.
4. Stavite tijesto u posudu.
5. Zatvorite poklopac.
6. Koristite gumb  za odabir  u izborniku.
7. Odaberite vrijeme kuhanja. Zadano vrijeme je 40 minuta.
8. Zadano vrijeme je 40 minuta.
9. Gumb h i min možete koristiti samo kada treperi vrijeme prikazano na displayu.
10. Koristite gumb min za kretanje kroz mogućnosti displaya (5, 10, 15, 20, 25, 30, 35, 40, 45, 50 i 55).
11. Koristite gumb h za kretanje kroz mogućnosti displaya (1 i 2).
12. Za poništavanje postavke od 2 sat, ponovno pritisnite gumb h dok na displayu treperi vrijeme.











- Ako uređaj ne koristite duže od 2 minute, isti će se prebaciti u stanje čekanja.
- 13. Kada ste postavili vrijeme, pritisnite .
- 14. Na displayu će otpočeti odbrojavanje.
- 15. Na kraju postupka kuhanja, uređaj će se prebaciti u način „održavanje toplim“.
- 16. Indikatorsko svjetlo  će se upaliti.
- 17. Najbolje je izvaditi hranu čim se skuha kako ne bi postala gnjecava.
- 18. Pritisnite  gumb. Otvorite poklopac. Izvadite hranu.

ODRŽAVANJE TOPLIM (KEEP WARM)

- Ako želite koristiti značajku održavanje toplim nakon programa koji to ne podržava, tada, kada je jedino što je prikazano na displayu trepereće svjetlo , pritisnite .
- Pritisnite  kako biste deaktivirali tu značajku.

TAJMER

- Kod programa juha , jogurt , kruh , para  i porridge (zobena kaša)  možete koristiti tajmer odgode.
- Uradite to odmah nakon postavljanja vremena kuhanja i prije pritiska na start :
- 1. Pritisnite  gumb. Indikatorsko svjetlo  će se upaliti.
- 2. Odlučite kada želite da hrana bude spremna.
- 3. Na primjer, ako je sada 2:00 sata, a želite da hrana bude spremna u 9:00 sati, vrijeme morate postaviti na 7 sati.
- 4. Da biste namjestili točno vrijeme u satima i minutama, koristite tipke **h** i **min**.
- 5. Pritisnite  gumb.

ČIŠĆENJE I ODRŽAVANJE







1. Izvucite utikač iz utičnice i ostavite uređaj da se ohladi.
2. Izvucite utikač iz električne utičnice, potom izvucite konektor iz ulaznog priključka uređaja.
3. Uz zatvoren poklopac, uhvatite vrh filtra i izvucite ga iz poklopca (SL. A).
4. Okrenite ga kako bi se vidjele oznake na prednjem rubu.
5. Brzo pridržite poklopac filtra i okrenite ostali dio filtra prema otvorenom lokotu  (SL. B).
6. Pritisnite na spojke na dnu unutarnjeg poklopca i skinite ga s uređaja (SL.C).
7. Operite ručno odvojive dijelove.
8. Obrišite sve površine čistom vlažnom krpom.
9. Nemojte prati bilo koji dio uređaja u perilici posuđa.
10. Ponovno sklopite filter i vratite ga u poklopac.
11. Zamijenite unutarnji poklopac u poklopcu.

RECIKLAŽA



Kako bi se izbjegle štetne posljedice na okoliš i zdravlje zbog opasnih supstanci, uređaji i punjive i nepunjive baterije obilježene jednim od ovih simbola ne smiju se zbrinjavati kao nerazvrstani komunalni otpad. Uvijek odložite električne i elektroničke proizvode i , gdje je primjenljivo, punjive i nepunjive baterije, u odgovarajućem zvaničnom mjestu za sakupljanje/reciklažu.







RECEPTI







	žlica (15 ml)
	čajna žličica (5 ml)
g	grami
ml	mililitri
	mjerica
	štapčić/rebro (celera)
	pregršt
	jaje, srednje (53-63 g)





	prstohvat
	vezica
	grančica
	režanj (režnjevi)
	limenka
	staklenka
	vrećica (7 g)
	jaje, veliko (63-73 g)

IZRAZITO LJUTA GOVEDINA S ČILIJEM NA NJUJORSKI NAČIN

GULAŠ

450 g	pirjanje govedine
3 	češnjak, oguljenog i nasjeckanog
2 	mljeveni kumin
1 	cayenne paprike
1 	dimljena paprika / čili chipotle prah
1	zelene paprike
1 	sol
1 	lišća bosiljka, grubo nasjeckanog



1 	maslinovog ulja
2	sjeckani luk
2 	čilija u prahu
2 	umak od rajčice
2 	rajčica
1 	lovorov list
1 	crnog papra
1 	graha





Otvorite poklopac. Dodajte ulje. U izborniku odaberite  i pritisnite . Nasjeckajte govedinu, rajčice i paprike na komadiće veličine zalogaja. Popecite meso te ga izvadite. Dodajte luk, češnjak i sve bilje. Kuhajte dok luk ne omekša. Dodajte meso. Ostavite grah sa strane. Dodajte ostale sastojke. Za zaustavljanje programa pritisnite dvaput na . Zatvorite poklopac. Odaberite . Grah dodajte 30 minuta prije završetka kuhanja. Ako je na kraju programa meso i dalje žilavo, dodajte šalicu vode i pustite da program za meso radi dodatnih 30 minuta.

IRSKI STEW (PIRJANA JANJETINA) S OKRUGLICAMA OD KOZJEG SIRA

GULAŠ





za stew (pirjana janjetina):

1.8 kg	janjeća lopatica (kuhana)
250 g	slanine u trakicama
950 ml	janjeći temeljac
1	veliki sjeckani luk
2 	štapčić celera, nasjeckan
2 	pirea od rajčice





1 	maslinovog ulja
3 	češnjaka (zgnječenih) sol i papar
2	sjeckana mrkva
2 	ružmarin, nasjeckan
1 	kukuruzna krupica

za okruglice:

100 g	brašna s dodatkom praška za pecivo
50 g	salo
75 ml	vode
40 g	kozji sir (meki)
1 	suhog majorana

1 	praška za pecivo
1 	sol
1 	sušenog peršina
1 	sušenog timijana
1 	crnog papra

za stew (pirjana janjetina):

Odvojite meso s kosti. Isijecite meso i slaninu na komadiće veličine zalogaja. Otvorite poklopac. U izborniku odaberite  i pritisnite . Dodajte temeljac. Pustite da proključa, uz miješanje. Kuhajte 10 minuta. Preljite temeljac u vrč. Dodajte ulje. Dodajte luk i pirjajte dok ne omekša. Dodajte meso, češnjak, bilje i ostalo povrće te kuhajte 5 minuta. Dodajte temeljac. Dodajte pire od rajčice. Za zaustavljanje programa pritisnite dvaput na . Zatvorite poklopac. Odaberite .

za okruglice:





Ručno umijesite sve sastojke. Smjesu podijelite na 6 okruglica. Ostavite da miruje 20 minuta.

za kraj:

U šalici napravite glatku pastu od kukuruzne krupice i malo vode. Otvorite poklopac 30 minuta prije kraja kuhanja. U stew (pirjana janjetina) umijesite pastu. Dodajte okruglice. Zatvorite poklopac. Sačekajte dok se program ne završi, potom služite. Nevjerovatna zdjela omiljene domaće delicije!

- Ako nemate kuhane janjetine, umjesto u programu za pirjanje janjetine možete koristiti svježu janjetinu u programu za sporo kuhanje te nastaviti od točke vezane uz okruglice.











POVRĆE I KUS-KUS S ČILIJEM

1	crveni sjeckani luk
1	veliki sjeckani luk
2 	češnja, oguljenog i nasjeckanog
1	crvena paprika, bez sjemenki i nasjeckana
1	žuta paprika, bez sjemenki i nasjeckana
1	narančasta paprika, bez sjemenki i nasjeckana
1 	mljeveni korijander
1 	pirea od rajčice
850 ml	temeljca od povrća
2 	ljuti umak od rajčice
120-140 ml	kus-kus





za sluzenje:

ribani sir
mala vezica korijandera, nasjeckanog

SPORO KUHANJE

1 	maslinovog ulja
1 	lima grah
1 	grah cannellini
1 	zeleni jalapenos
1 	graha
1 	nasjeckanih rajčica
2 	mljeveni kumin
1 	šećera
2 	čilija u prahu
2 	sušenog origana

kiselo vrhnje

Otvorite poklopac. Dodajte ulje. U izborniku odaberite  i pritisnite . Dodajte luk i češnjak. Kuhajte dok luk ne omekša. Iscijedite grah te ga dodajte. Ostavite kus-kus sa strane. Dodajte ostale sastojke. Za zaustavljanje programa pritisnite dvaput na . Zatvorite poklopac. Odaberite . Kus-kus dodajte 30 minuta prije završetka kuhanja. Ako je kuhanje već završeno, u izborniku odaberite  i kuhajte za dodatnih 20-ak minuta. Poslužite u zdjeli s pregršt sira, pokapajte kiselim vrhnjem i pospite svjež korijander. Za klasičan vegetarijanski čili, izostavite kus-kus.

DOMAĆI JOGURT

JOGURT





1200 ml mlijeka

100 ml jogurta

moгуćnost okusa



50 g mješavina smrznutih ljetnih bobica







1  meda



Otvorite poklopac. Dodajte mlijeko. U izborniku odaberite  i pritisnite . Pustite da se mlijeko ugrije dok se na rubovima ne počnu stvarati mjehurići. Za zaustavljanje programa pritisnite dvaput na . Ostavite mlijeko da se ohladi na temperaturi između 37°C i 45°C. Umiješajte jogurt u mlijeko. Moraju biti dobro promiješani, jer će u protivnom jogurt biti grudast. Zatvorite poklopac. U izborniku odaberite  i pritisnite . Sačekajte dok se program ne završi. Stavite jogurt u hladnjak da se potpuno ohladi. Blago zagrijte bobice u tavi. Dodajte med. Kada se bobice počnu raspadati, uklonite ih s vatre, pustite da se ohlade te ih pomiješajte s jogurtom. Ako jogurt želite pohraniti, staklenke koje ćete za to koristiti morate sterilizirati. Zagrijte ih u pećnici na temperaturi od 100 °C u trajanju od 10 minuta. Jogurt možete držati u hladnjaku do 2 tjedna.

MAROKANSKI RIBLJI TAGINE





RIBA





2 	češnja, oguljenog i nasjeckanog
1	crvena paprika, bez sjemenki i nasjeckana
2	nasjeckanih rajčica
1 	mljeveni đumbir
1	štapić cimeta
120 ml	bijelog vina
120 ml	riblji temeljac
675 g	riba (bakalar/koljak/lososa)
1	mala vezica korijandera, nasjeckanog

1	sjeckani luk
2 	štapić celera, nasjeckan
1 	mljeveni kumin
1 	kurkuma
1 	harissa pasta
1 	pirea od rajčice
1	limun
1 	zeleno masline sol i papar

Ostavite korijander sa strane. Otvorite poklopac. Dodajte ostale sastojke. Zatvorite poklopac. U izborniku odaberite  i pritisnite . Kuhajte dok riba ne dobije pahuljastu teksturu (40 - 60 minuta). Za zaustavljanje programa pritisnite dvaput na . Dodajte korijander. Začinite po želji i poslužite. Ovo ide odlično s kus-kusom.

JUHA SA SUHIM GRAŠKOM I SVINJSKOM KOLJENICOM SPORO KUHANJE



1150 ml	pilećeg temeljca	1	sitno sjeckani luk
225 g	suhi grašak	1	sjeckana mrkva
1 	štapić celera, nasjeckan	2 	češnjaka (zgnječenih)
1 	sitno sjeckana majčina dušica	1 	lovorov list
1	svinjska koljenica		crnog papra

Otvorite poklopac. Dodajte temeljac. U izborniku odaberite  i pritisnite . Pustite da proključa, uz miješanje. Kuhajte 10 minuta. Dodajte ostale sastojke. Za zaustavljanje programa pritisnite dvaput na . Zatvorite poklopac. Odaberite . Sačekajte dok se program ne završi. Izvadite svinjsku koljenicu. Odvojite kožu i kosti. Isjeckajte meso na kockice. Izvadite lovorov list. Napravite pire od suhog graška koristeći stražnji dio drvene žlice. Dodajte meso. Začinite po želji i poslužite. Raj u zdjeli!

LOSOS S MJEŠAVINOM PIKANTNIH ZAČINA

RIBA

2	fileti lososa (s kožom)	1 	maslinovog ulja
1 	paprike	1 	čilija u prahu
1/2 	mljeveni kumin	1 	sol i papar
1 	mekani smeđi šećer	1	limun

Pomiješajte mljevenu papriku, čili u prahu, kumin, šećer, sol i papar. Pospite preko fileta lososa. Otvorite poklopac. Dodajte ulje. U izborniku odaberite  i pritisnite . Sačekajte nekoliko minuta da se zagrije ulje. Dodajte filete s kožom okrenutom prema dolje. Zatvorite poklopac. To je odlična kombinacija kuhanja na pari i prženja komada ribe, pri čemu koža postaje hrskava. Poslužite s kriškom limuna. Odličan lagani obrok.



ČOKOLADNI BROWNIE KOLAČ

KOLAČ

170 g	neslani maslac	3	
340 g	šećera	1 	esencije vanilije
170 g	kakao praha	1 	soli
110 g	kapljice mlječne čokolade	75 g	običnog brašna

za sluzenje:



sladoleda od vanilije (opcionalo)

Istopite maslac u tavi na laganoj vatri. U posudu postavite foliju premazanu maslacem. U posudi umutite rastopljeni maslac, šećer, kakao u prahu, brašno, jaja, vaniliju i sol. Čokoladne kapljice umiješajte laganim pokretima. Stavite tijesto na foliju u posudi. Zatvorite poklopac. U izborniku odaberite . Postavite vrijeme kuhanja na 1 sat i 30 minuta. Pritisnite  gumb. Kolač treba biti čvrst na rubovima i blago gnjecav u sredini. Kolač poslužite toplim sa sladoledom odozgo.

ARTIČOKA KUHANA NA PARI

PARA

1 	češnjaka, oguljenog i nasjeckanog	2	globus artičoke
	grančice bilja (estragon, metvica, peršin, majčina dušica)	1	limun

Isijecite limun. Odrežite dršku do dna svake artičoke. Odrežite gornju četvrtinu svake artičoke. Uklonite oštećene listove. Utrljajte izrezane površine kriškom limuna. Stavite kriške limuna u košaru. Dodajte grančice bilja. Dodajte češnjak. Stavite artičoku na vrh. Nalijte vodu do razine 2 na ljestvici s lijeve strane unutar posude. Stavite košaru odozgo na posudu. Zatvorite poklopac. U izborniku odaberite  i pritisnite . Artičoke su kuhane kada se vanjski listovi mogu lako odvojiti. Poslužite ih tople ili hladne s vinaigrette umakom. Oduševljavajuće!

JEČMENA PREKUPA I GRAH BORLOTTI KAO OBROK U JEDNOM LONCU

GULAŠ

1 	maslinovog ulja	1 	grah borlotti
175 g	ječmena prekupa	1	sitno sjeckani luk
1 	nasjeckanih rajčica	1 	pirea od rajčice
1000 ml	temeljca od povrća	2 	peršin (nasjeckan)
125 ml	suho crveno vino		sol i papar

za služenje:

ulje od ljutog čilija (opcionalno)

Otvorite poklopac. U izborniku odaberite ☞ i pritisnite ⬠. Dodajte temeljac. Pustite da proključa, uz miješanje. Kuhajte 10 minuta. Prelijte temeljac u vrč. Dodajte ulje. Dodajte luk i pirjajte dok ne omekša. Dodajte vino i kuhajte nekoliko minuta. Dodajte ječmenu prekupu i miješajte dok ne počne pokazivati boju crvenog vina. Iscijedite grah te ga dodajte. Dodajte rajčice. Dodajte temeljac. Za zaustavljanje programa pritisnite dvaput na ⏏. Zatvorite poklopac. Odaberite ☞. Otvorite poklopac 30 minuta prije kraja kuhanja. Provjerite količinu tekućine u posudi. Ako je potrebno, dolijte 150 ml vruće vode. Zatvorite poklopac. Sačekajte dok se program ne završi. Poslužite sa svježim kruhom s hrskavom koricom i pokapajte uljem od ljutog čilija.

SPONGE PUDDING (MEKI BISKVIT) SA SIRUPOM

PARA ☞

115 g	maslaca	2	Ⓜ
100 g	finog šećera u prahu	¼	☞ esencije vanilije
175 g	brašna s dodatkom praška za pecivo	2	☞ mlijeka
4	☞ zlatni sirup		

Istucite jaja u zdjeli. U posudi kremasto istucite maslac i šećer. Postepeno dodajte jaja, pa vaniliju i na kraju brašno. Umiješajte mlijeko. Podmažite vatrostralnu zdjelu zapremine 1200 ml. Na dno vatrostralne zdjele nalijte sirup i preko njega smjesu. Prekrijte pergament papirom i potom folijom te vrh svežite vezicom. Otvorite poklopac. Vatrostralnu zdjelu stavite u posudu uređaja. U posudu uređaja dolijte dovoljno ključajuće vode tako da bude 3 cm ispod vrha vatrostralne zdjele. Zatvorite poklopac. U izborniku odaberite ☞. Postavite vrijeme kuhanja na 1 sat i 30 minuta. Pritisnite ⬠ gumb. Sačekajte dok se program ne završi. Preokrenite na tanjur i poslužite toplim. Ovo je odličan pudding (meki biskvit) za bilo koje doba godine!

RIŽOTO S CIKLOM U VIŠENAMJENSKOM KUHALU

PORRIDGE (ZOBENA KAŠA) / RIŽOTO ☞



400 g	cikla	2	☞ maslinovog ulja
250 g	riža arborio / riža za rižoto	1	☞ sitno sjeckani luk
250 ml	bijelog vina	2	☞ češnjak, oguljenog i nasjeckanog
900 ml	temeljca od povrća / pilećeg temeljca	1	☞ sitno sjeckana majčina dušica

za kraj:

100 ml	jogurta	1	☞ peršin (nasjeckan)
1	☞ maslaca		

Otvorite poklopac. U izborniku odaberite ☞ i pritisnite ⬠. Dodajte temeljac. Pustite da proključa, uz miješanje. Kuhajte 10 minuta. Prelijte temeljac u vrč. Za zaustavljanje programa pritisnite dvaput na ⏏. U izborniku odaberite ☞ i pritisnite ⬠. Ostavite da se ugrije. Ogulite ciklu i isijecite ju u kockice veličine 1 cm. U posudu stavite ciklu, češnjak i luk. Kuhajte dok luk ne omekša. Umiješajte rižu. Zatvorite poklopac i kuhajte 3 - 4 minute. Otvorite poklopac. Umiješajte vino. Zatvorite poklopac i kuhajte 3 - 4 minute. Otvorite poklopac. Dodajte majčinu dušicu. Dodajte temeljac. Zatvorite poklopac. Sačekajte dok se program ne završi. Provjerite rižu. Trebalo bi da ne bude raskuhana, ali ne bi smjela biti pretvrda. Ako nije dovoljno kuhana, dodajte malo vode i kuhajte još nekoliko minuta. Umiješajte maslac. To će rižotu dati sjaj. Poslužite sa žlicom jogurta i pospite peršinom. Ovo je savršeno kao predjelo ili lagani ručak.

PORRIDGE (ZOBENA KAŠA)

2  zobene kaše
1/4  soli



za služenje:

tamno smeđeg šećera



PORRIDGE (ZOBENA KAŠA) / RIŽOTO

vode
2  šećera

mlijeka / jednostavnog vrhnja

Otvorite poklopac. Dodajte zobene pahuljice, sol i šećer. Dolijte vodu do razine 1/2 na ljestvici s desne strane unutar posude. Zatvorite poklopac. U izborniku odaberite  i pritisnite . Sačekajte dok se program ne završi. Poslužite s mlijekom ili vrhnjem. Pospite tamnosmeđim šećerom. Ako želite, možete dodati sjeckane sušene marelice ili polovice šljiva (bez koštica) 15 minuta prije isteka vremena kuhanja. Preostali porridge (zobenu kašu) možete držati u hladnjaku do 2 dana, potom ga treba zagrijati.

PORRIDGE (ZOBENA KAŠA) S ORASIMA

1/2  valjana zob
120 ml mlijeka
1  mljevenog cimeta



za služenje:

zlatni sirup

PORRIDGE (ZOBENA KAŠA) / RIŽOTO

vode
3  dehidrirani kokos



usitnjeni badem

Otvorite poklopac. Dodajte zob, cimet, kokos i mlijeko. Dolijte vodu do razine 1/2 na ljestvici s desne strane unutar posude. Zatvorite poklopac. U izborniku odaberite  i pritisnite . Sačekajte dok se program ne završi. Pokapajte zlatnim sirupom i preko toga pospite usitnjeni badem.

SODA KRUH

1  smjesa za soda kruh
350 ml vode



maslaca

Otvorite poklopac. Premažite posudu maslacem. U izborniku odaberite . Zatvorite poklopac. Postavite vrijeme kuhanja na 2 sata i 15 minuta. Pritisnite  gumb. Ostavite da se ugrije. U posudu stavite smjesu za irski soda kruh. Dolijte vodu. Miješajte rukom i oblikujte u kuglu. Otvorite poklopac. Stavite tijesto u posudu. Tijesto podijelite u četvrtine koristeći plastičnu lopaticu. Zatvorite poklopac. Otvorite poklopac 30 minuta prije kraja kuhanja. Okrenite kruh. To će gornjoj strani kruha dati nešto boje i učiniti ju hrskavom. Sačekajte dok se program ne završi. Ostavite da se ohladi na rešeci. Poslužite zasebno sa zasoljenim maslacem ili uz obrok.





KRUH

BIJELI KRUH

1  zlatni sirup
320 ml mlijeka
500 g oštrog bijelog brašna za kruh

1  maslaca
1  suhog kvasca
1  soli





KRUH

Otvorite poklopac. Dodajte mlijeko. U izborniku odaberite  i pritisnite . Pustite da se mlijeko ugrije dok se na rubovima ne počnu stvarati mjehurići. Prelijte mlijeko u vrč. Za zaustavljanje programa pritisnite dvaput na . Ostavite mlijeko da se ohladi na temperaturi između 37°C i 45°C. Istopite maslac u tavi na laganoj vatri. U posudi pomiješajte brašno i sol. Dodajte kvasac, maslac i sirup. Dodajte mlijeko, izgnječite i oblikujte u kuglu. Ako je smjesa veoma ljepljiva, dodajte nešto više brašna. Prekrijte i ostavite na toplom mjestu u trajanju od 10 minuta. Ponovno izgnječite. Prekrijte i ostavite na toplom mjestu u trajanju od 10 minuta. Otvorite poklopac. U izborniku odaberite  i pritisnite . Zatvorite poklopac. Otvorite poklopac 30 minuta prije kraja kuhanja. Okrenite kruh. To će gornjoj strani kruha dati nešto boje i učiniti ju hrskavom. Sačekajte dok se program ne završi. Poslužite uz komadiće maslaca.



ZAČINJENA RIŽA





RIŽA





2 	riža		
1	kocka za juhu (povrtna)	2	sjeckana mrkva
1	crvena paprika, bez sjemenki i nasjeckana	2 	štapic celera, nasjeckan
1 	kurkuma	1 	grašak (opcionarno)

Otvorite poklopac. Stavite rižu u posudu. Nalijte vodu do razine 2 na ljestvici s lijeve strane unutar posude. Izdobite kockicu za juhu i umiješajte u vodu. Dodajte ostale sastojke. Zatvorite poklopac. Odaberite . Sačekajte dok se program ne završi, potom služite. Ako riža nije dovoljno kuhana, ostavite ju još nekoliko minuta da se pari uz zatvoreni poklopac.

JUHA S KOMADIMA RAJČICE







JUHA





1	sjeckani luk	1 	maslinovog ulja
1 	nasjeckanih rajčica	2	nasjeckanih rajčica
1	crvena paprika, bez sjemenki i nasjeckana	2	krumpira
550 ml	pilećeg temeljca	1 	pirea od rajčice
1 	mješavine osušenog aromatičnog bilja	1 	crnog papra

Otvorite poklopac. Dodajte temeljac. U izborniku odaberite  i pritisnite . Pustite da prokluču, uz miješanje. Kuhajte 10 minuta. Prelijte temeljac u vrč. Za zaustavljanje programa pritisnite dvaput na . Ogulite krumpir i isijecite ga na kockice. U izborniku odaberite  i pritisnite . Dodajte ulje. Dodajte luk i papriku. Kuhajte dok luk ne omekša. Dodajte temeljac. Dodajte ostale sastojke. Zatvorite poklopac. Sačekajte dok se program ne završi. Začinite po želji. Poslužite s kruhom s hrskavom koricom.

JUHA S CHORIZO KOBASICOM, KUPUSOM I JABUKOM







JUHA



¼	sitno sjeckana chorizo kobasica	1	sitno sjeckani luk
1	jabuka	2	sjeckana mrkva
2 	štapic celera, nasjeckan	2	nasjeckanih rajčica
¼	sitno sjeckani proljetni kupus	1 	pirea od rajčice
2 	češnja, oguljenog i nasjeckanog	1 	cayenne paprike
1 	soli	1 	crnog papra
850 ml	temeljca od povrća		

Otvorite poklopac. U izborniku odaberite  i pritisnite . Popržite chorizo kobasicu u trajanju od 2 minute. Dodajte luk i češnjak. Kuhajte dok luk ne omekša. Ogulite, odstranite jezgru i isijecite jabuku. Dodajte ostale sastojke. Za zaustavljanje programa pritisnite dvaput na . Zatvorite poklopac. U izborniku odaberite  i pritisnite . Sačekajte dok se program ne završi. Ovo je odlična juha koja će, ako je ostavite preko noći u hladnjaku, razviti još bolji okus.

PILETINA S RAJČICOM I GLJIVAMA

MESO



2	pileća prsa, bez kože i kostiju	1 	maslinovog ulja
450 g	sjeckane smeđe gljive	1 	nasjeckanih rajčica
2 	češnja, oguljenog i nasjeckanog	1 	umak od rajčice
1 	Worcester sosa	1 	sušenog origana
	sol i papar		



Otvorite poklopac. U izborniku odaberite  i pritisnite . Dodajte ulje. Začinite pileća prsa soli i paprom te ih stavite u posudu. Okrećite meso kako biste ga zapekli s obje strane. Dodajte češnjak i gljive. Kuhajte 3 - 4 minute, okrećući piletinu jedanput. Dodajte rajčice, Worcester umak, umak od rajčice i origano. Nastavite kuhati, okrećući piletinu još jedanput. Provjerite je li piletina skuhana. Poslužite s tjesteninom, krumpirom ili rižom. Brz i ukusan obrok kojeg se može pohraniti.

REBRA PIRJANA U CRNOM PIVU S LOVOROVIM SIRUPOM I SOJINIM UMAKOM



MESO 

1 kg svinjska trbušna rebra
350 ml Guinness / crno pivo
140 ml goveđi / svinjski temeljac
60 ml lovorov sirup / meda





1 sjeckani luk
1  maslinovog ulja
3  češnjak, oguljenog i nasjeckanog
2  tamni sojin umak





Otvorite poklopac. U izborniku odaberite . Dodajte ulje. Postavite vrijeme kuhanja na 1 sat i 45 minuta. Pritisnite  gumb. Dodajte rebra i popecite ih 5 minuta uz povremeno okretanje. Skinite rebra. Dodajte luk i češnjak. Kuhajte dok luk ne omekša. Vratite rebra u posudu. Umiješajte Guinness, temeljac, lovorov sirup i sojin umak. Zatvorite poklopac. Sačekajte dok se program ne završi. Začinite po želji i poslužite. Odlično kao predjelo ili kao dio ručka po slobodnom izboru.

GOVEĐA PRSA KAO OBROK U JEDNOM LONCU

1 kg goveđa prsa
2  češnjak, oguljenog i nasjeckanog
50 g narezana chorizo kobasica
2 sjeckani crveni luk
600 ml goveđi temeljac
2  mješavine osušenog aromatičnog bilja
6-8 krumpir (mali)
2  Vorčester sosa

SPORO KUHANJE

2  pirea od rajčice
2  lovorov list
2 mrkve
3  celer
2  ružmarin, nasjeckan
1  nasjeckanih rajčica
sol i papar

Ostavite koru na krumpiru. Krumpir, mrkvu i celer isijecite na komadiće. Goveđa prsa začinite soli i paprom. Otvorite poklopac. U izborniku odaberite  i pritisnite . Dodajte temeljac. Pustite da proključa, uz miješanje. Kuhajte 10 minuta. Preljite temeljac u vrč. Popržite chorizo kobasicu u trajanju od 2 minute. Dodajte meso. Popecite sa svih strana. Dodajte luk, češnjak, krumpir, celer i mrkvu. Također dodajte bilo kakvo drugo korjenasto povrće koje trebate iskoristiti. Kuhajte dok luk ne omekša. Dodajte temeljac. Dodajte ostale sastojke. Za zaustavljanje programa pritisnite dvaput na . Odaberite . Sačekajte dok se program ne završi, potom služite. Kuhanje u trajanju od 8 sati neće škoditi, iako će hrana najvjerojatnije biti pripremljena već nakon 5 sati.

Preberite navodila, jih shranite na varnem in jih predajte skupaj z napravo, če jo posredujete naprej. Pred uporabo odstranite vso embalažo.

POMEMBNA VAROVALA

Sledite osnovnim varnostnim ukrepom, vključno z:

To napravo smejo uporabljati otroci, stari najmanj 8 let, in osebe z zmanjšanimi fizičnimi, čutnimi ali duševnimi sposobnostmi ali s pomanjkljivimi izkušnjami in znanjem, če so pri tem pod nadzorom/dobijo navodila in razumejo s tem povezana tveganja. Otroci se z napravo ne smejo igrati. Otroci ne smejo čistiti in vzdrževati naprave, če niso starejši od 8 let ter pod nadzorom. Napravo in kabel varujte pred dosegom otrok, mlajših od 8 let.

Če je priključek ali kabel poškodovan, ga morate zamenjati s posebnim kompletom, ki ga dobite pri izdelovalcu ali njegovemu prodajnemu zastopniku za nadomestne dele.

 Te naprave ne uporabljajte v bližini kadi, prh, lavorjev in drugih posod z vodo. Napravo postavite na stabilno vodoravno površino, ki je odporna proti vročini.

 Zloraba naprave lahko povzroči telesne poškodbe.

 Površine naprave se segrejejo. Zaradi preostale toplote bodo površine vroče tudi po uporabi.

- V napravo ne dajajte zamrznjenega mesa ali perutnine – pred uporabo ga v celoti odmrznite.
- Meso, perutnino in sorodne izdelke (mleto meso, burgerji itd.) pecite toliko časa, da so sokovi bistri. Ribe pecite toliko časa, da je meso v celoti neprosojno.
- Ničesar ne poskušajte kuhati v ohišju kuhalnika – kuhajte samo v izmenljivi skledi.
- Posode ne napolnite nad oznako max.
- Naprave ne pokrivajte in nanjo ne dajajte drugih predmetov.
- Vtič odstranite iz električne vtičnice, nato pa odstranite priključek z napajalnega dovoda naprave.
- Odklopite napravo, ko ni v uporabi.
- Ne uporabljajte nobene druge opreme ali priključka, razen priloženih.
- Naprave ne uporabljajte za nič drugega kot za namene, ki so opisani v teh navodilih.
- Naprave ne upravljajte, če je poškodovana ali če ne deluje pravilno.

SAMO ZA GOSPODINJSKO UPORABO

RISBE



- | | |
|-----------------------|---------------------|
| 1. Nadzorna plošča | 5. Merilna posodica |
| 2. Pokrov | 6. Košara |
| 3. Zaklepanje pokrova | 7. Skleda |
| 4. Notranji pokrov | 8. Priključek |

PRIPRAVA



1. Napravo postavite na stabilno vodoravno površino, ki je odporna proti vročini.

2. Naprave postavljajte v bližino ali pod zavese, police ali omare ali v bližino česar koli, kar bi se lahko poškodovalo zaradi uhajanja pare.
3. Pri roki imejte kuhinjske rokavice (ali krpo) in toplotno odporno prevleko ali krožnik, na katerega boste dali skledo po kuhanju.
4. Skledo postavite v kühalnik.
5. Skledo zavrtite za četrt obrata v vsako stran, da zagotovite, da ima dno skleda dober stik z grelnikom.



RIŽ

1. Z merilno posodico dajte riž v skledo.
2. Ne uporabite več kot 10 posodic riža.
3. Uporabite lestvico na levi strani notranjosti skleda, ki ima oznake od 2 do 10.
4. Skledo napolnite z vodo do številke, ki se ujema z uporabljenim številom posodic riža.
5. Zaprite pokrov.
6. Pritisnite gumb . Gumb bo svetil.
7. Zunanji segmenti prikazovalnika bodo med segrevanjem hrane utripali.
8. Prikazovalnik bo nato pokazal preostali čas kuhanja (13 minut) in odšteval.
9. Ob koncu časa kuhanja se naprava preklopi v način »ohranjanje toplote«. Sveti lučka .
10. Odprite pokrov.
11. Dvignite skledo in jo postavite na ploščo, odporno na vročino, ali krožnik.
12. Pritisnite gumb .
13. Z lopatico premešajte riž, da uide vsa para.
14. Včasih po plast riža v stiku s posodo dobila skorjo.
15. Če je ne želite, jo lahko odstranite z lopatico, ko riž postrežete.

POČASNO KUHANJE

1. Popečeno meso in zelenjava (glejte »POPEČENO/SOTIRANO/OMEHČANO/KUHANO«).
2. Zavrite tekočino za kuhanje (glejte »POPEČENO/SOTIRANO/OMEHČANO/KUHANO«).
3. Trdne sestavine dajte v skledo in dodajte tekočino za kuhanje.
4. Zaprite pokrov.
5. Pritisnite gumb . Gumb bo svetil.
6. Prikazovalnik bo pokazal 8 ur in odšteval.
7. Ob koncu časa kuhanja se naprava preklopi v način »ohranjanje toplote«. Sveti lučka .
8. Pritisnite gumb . Odprite pokrov. Odstranite hrano.





DUŠENJE

1. Popečeno meso in zelenjava (glejte »POPEČENO/SOTIRANO/OMEHČANO/KUHANO«).
2. Zavrite tekočino za kuhanje (glejte »POPEČENO/SOTIRANO/OMEHČANO/KUHANO«).
3. Trdne sestavine dajte v skledo in dodajte tekočino za kuhanje.
4. Zaprite pokrov.
5. Pritisnite gumb . Gumb bo svetil.
6. Prikazovalnik bo pokazal 1 uro in odšteval.
7. Ob koncu časa kuhanja se naprava preklopi v način »ohranjanje toplote«. Sveti lučka .
8. Pritisnite gumb . Odprite pokrov. Odstranite hrano.





MESO

1. Hrano premažite z jedilnim oljem.
2. Začimbe vtrite v površino hrane.
3. V skledo dajte žlico jedilnega olja.
4. Postavite hrano v skledo.
5. Zaprite pokrov.
6. Čas priprave je odvisen od velikosti kosov.



7. Naenkrat ne kuhajte več kot 500 g hrane.
8. Priporočamo, da kuhate 10 minut na 100 g govedine in še dodatnih 10 minut.
9. Svinjine in perutnine ne kuhajte manj kot 5, 10, 15, 20, 25, 30 minut.
10. Z gumbom  izberite  v meniju.
11. Izberite čas kuhanja. Privzeti čas je 20 minut.
12. Gumba za ure in minute lahko uporabljate le, kadar utripa čas na prikazovalniku.
13. Z gumbom za minute izberite možnosti na prikazovalniku (10, 15, 20, 25, 5, 10, 15, 20, 25, 30, 35, 40, 45, 50 in 55).
14. Če želite kuhati 1 uro, pritisnite gumb za uro.
15. Če želite razveljaviti nastavitev za 1 uro, znova pritisnite gumb za uro, ko utripa čas na prikazovalniku.
- Če 2 minuti ne storite ničesar, se naprava preklopi v pripravljenost.
16. Ko nastavite čas, pritisnite .
17. Prikazovalnik začne odštevati.
18. Ob koncu časa kuhanja se naprava preklopi v način »ohranjanje toplote«. Sveti lučka .
19. Pritisnite gumb . Odprite pokrov. Odstranite hrano.

JUHA

1. Popečeno meso in zelenjava (glejte »POPEČENO/SOTIRANO/OMEHČANO/KUHANDO«).
2. Trdne sestavine dajte v skledo in dodajte tekočino za kuhanje.
3. Zaprite pokrov.
4. Z gumbom  izberite  v meniju.
5. Izberite čas kuhanja. Privzeti čas je 1 ura.
6. Gumba za ure in minute lahko uporabljate le, kadar utripa čas na prikazovalniku.
7. Z gumbom za minute izberite možnosti na prikazovalniku (10, 15, 20, 25, 5, 10, 15, 20, 25, 30, 35, 40, 45, 50 in 55).
8. Z gumbom za h izberite možnosti na prikazovalniku (1, 2, 3, 4 in 5).
9. Če želite razveljaviti nastavitev za 5 uro, znova pritisnite gumb za uro, ko utripa čas na prikazovalniku.
- Če 2 minuti ne storite ničesar, se naprava preklopi v pripravljenost.
10. Ta program omogoča uporabo časovnika (glejte ČASOVNIK).
11. Pritisnite gumb .
12. Prikazovalnik začne odštevati.
13. Ob koncu časa kuhanja se naprava preklopi v način »ohranjanje toplote«. Sveti lučka .
14. Pritisnite gumb . Odprite pokrov. Odstranite hrano.

JOGURT

Jogurtna kultura

Uporabite lahko 5, 10, 15, 20, 25, 30 ml (2 veliki žlici):

- Navadnega živega jogurta – biti mora svež (poiščite takšnega, ki ima dolg rok uporabnosti). Različne znamke se obnašajo različno.

Jogurta, ki ste ga naredili prej.





- Bakterije sčasoma oslabijo, tako da lahko to storite le 10-krat, preden morate uporabiti novo kulturo.
- Liofilizirane kulture za jogurt, ki jo dobite v lekarni ali trgovini z zdravo hrano.
- Če se navodila na embalaži kulture razlikujejo od teh navodil, upoštevajte navodila na embalaži.

Mleko





- Potrebujete 1 liter mleka.
- Polnomastno mleko daje gostejši jogurt kot mleko z malo mlečne maščobe.
- Če želite še gostejši jogurt, lahko tekočemu mleku dodate do 8 žlic mleka v prahu.
- Uporabite lahko tudi mleko v prahu z dodano vodo ali zgoščeno mleko iz konzerve.

Izdelava jogurta

1. Bakterije v mleku morate uničiti, da ne bodo konkurirale bakterijam v kulturi za jogurt.
2. Ko segrevate mleko, pustite, da se kultura za jogurt ogreje na sobno temperaturo.
3. Odprite pokrov.

4. Uporabite program KUHANJE V PARI (POPEČENJE/SOTIRANJE/MEHČANJE/KUHANJE), da mleko segrejete skoraj do vrenja.
5. Mleko naj se greje, dokler ne začne brbotati ob robovih.
6. Počakajte, da se mleko ohladi na temperaturo od 37 do 45°C.
7. Kulturo za jogurt vmešajte v mleko.
8. Zmešati jo morate temeljito, sicer bo imel jogurt grudice.
9. Zaprite pokrov.
10. Z gumbom  izberite  v meniju.
11. Izberite čas kuhanja. Privzeti čas je 8 ur.
12. Gumba za ure in minute lahko uporabljate le, kadar utripa čas na prikazovalniku.
13. Z gumbom za min izberite možnosti na prikazovalniku (10, 15, 20, 25, 5, 10, 15, 20, 25, 30, 35, 40, 45, 50 in 55).
14. Z gumbom za h izberite možnosti na prikazovalniku (6, 7, 8, 9 in 10).
15. Če želite razveljaviti nastavitev za 10 uro, znova pritisnite gumb za uro, ko utripa čas na prikazovalniku.
 - Če 2 minuti ne storite ničesar, se naprava preklopi v pripravljenost.
16. Ta program omogoča uporabo časovnika (glejte ČASOVNIK).
17. Pritisnite gumb .
18. Prikazovalnik začne odšteti.
19. Ob koncu časa kuhanja se naprava preklopi v pripravljenost.
20. Jogurta ne vzdržuje toplega.
21. Pritisnite gumb . Odprite pokrov. Odstranite hrano.





KRUH

1. Zamrznjeno testo pred uporabo dobro odmrznite.
2. Naenkrat ne kuhajte več kot 500 g hrane.
3. Skledo obrišite z jedilnim oljem.
4. Testo dajte v skledo.
5. Zaprite pokrov.
6. Z gumbom  izberite  v meniju.
7. Izberite čas kuhanja. Privzeti čas je 3 ur.
8. Gumba za ure in minute lahko uporabljate le, kadar utripa čas na prikazovalniku.
9. Z gumbom za min izberite možnosti na prikazovalniku (10, 15, 20, 25, 5, 10, 15, 20, 25, 30, 35, 40, 45, 50 in 55).
10. Z gumbom za h izberite možnosti na prikazovalniku (1, 2, 3, 4, 5 in 6).
11. Če želite razveljaviti nastavitev za 6 uro, znova pritisnite gumb za uro, ko utripa čas na prikazovalniku.
 - Če 2 minuti ne storite ničesar, se naprava preklopi v pripravljenost.
12. Ta program omogoča uporabo časovnika (glejte ČASOVNIK).
13. Pritisnite gumb .
14. Prikazovalnik začne odšteti.
15. Ob koncu časa kuhanja se naprava preklopi v način »ohranjanje toplote«. Sveti lučka .
16. Pritisnite gumb . Odprite pokrov. Odstranite hrano.



RIBE

1. Hrano premažite z jedilnim oljem.
2. Začimbe vtrite v površino hrane.
3. V skledo dajte žlico jedilnega olja.
4. Postavite hrano v skledo.
5. Zaprite pokrov.
6. Čas priprave je odvisen od velikosti kosov.
7. Naenkrat ne kuhajte več kot 500 g hrane.
8. Priporočamo, da kuhate 10 minut na 100 g teže.





9. Z gumbom  izberite  v meniju.
10. Izberite čas kuhanja. Privzeti čas je 20 minut.
11. Gumba za ure in minute lahko uporabljate le, kadar utripa čas na prikazovalniku.
12. Z gumbom za min izberite možnosti na prikazovalniku (10, 15, 20, 25, 5, 10, 15, 20, 25, 30, 35, 40, 45, 50 in 55).
13. Če želite kuhati 1 uro, pritisnite gumb za uro.
14. Če želite razveljaviti nastavev za 1 uro, znova pritisnite gumb za uro, ko utripa čas na prikazovalniku.
 - Če 2 minuti ne storite ničesar, se naprava preklopi v pripravljenost.
15. Ko nastavite čas, pritisnite .
16. Prikazovalnik začne odštevati.
17. Ob koncu časa kuhanja se naprava preklopi v način »ohranjanje toplote«. Sveti lučka .
18. Za najboljše rezultate hrano odstranite, takoj ko je končana, da se ne bo posušila.
19. Pritisnite gumb . Odprite pokrov. Odstranite hrano.

KUHANJE V PARI

1. Skledo napolnite s hladno vodo do oznake 6.
2. Košaro postavite na vrh sklede in vanjo položite hrano.
3. Za enakomerno kuhanje razrežite vse kose hrane na približno enako velikost.
4. Za grah ali kar koli, kar se lahko razlomi in pade v vodo, pripravite posodico iz aluminijaste folije.
5. Pri odstranjevanju posodice bodite previdni – nosite kuhinjske rokavice in uporabljajte kleščice oziroma žlice iz umetne mase.
6. Zaprite pokrov.
7. Z gumbom  izberite  v meniju.
8. Izberite čas kuhanja. Privzeti čas je 30 minut.
 - Te jedi bi se morale skuhati v privzetem času:

Hrana (sveža)	Količina
Zelen fižol	200g
Brstični ohrovt	200g
Brstični ohrovt	200g
Korenček (narezan)	400g
Brokoli	200g
Zelje	četrtnina
Koruzni storži	2

9. Gumba za ure in minute lahko uporabljate le, kadar utripa čas na prikazovalniku.
10. Z gumbom za min izberite možnosti na prikazovalniku (5, 10, 15, 20, 25, 30, 35, 40, 45, 50 in 55).
11. Z gumbom za h izberite možnosti na prikazovalniku (1 in 2).
12. Če želite razveljaviti nastavev za 2 uro, znova pritisnite gumb za uro, ko utripa čas na prikazovalniku.
 - Če 2 minuti ne storite ničesar, se naprava preklopi v pripravljenost.
13. Ta program omogoča uporabo časovnika (glejte ČASOVNIK).
14. Pritisnite gumb .
15. Prikazovalnik začne odštevati.
16. Ob koncu časa kuhanja se naprava preklopi v način »ohranjanje toplote«. Sveti lučka .
17. Za najboljše rezultate hrano odstranite, takoj ko je končana, da se ne bo omočila.
18. Pritisnite gumb . Odprite pokrov. Odstranite hrano.

POPEČENO/SOTIRANO/OMEHČANO/KUHANO

- Program KUHANJE V PARI ☁ lahko za 5, 10, 15, 20, 25, 30 minut uporabite s privzeto nastavitvijo in odprtim pokrovom kot vročo ponev, nato pa nadaljujete kuhanje z drugim programom.
- Uporabite ga z malo olja, da meso in zelenjavo popečete ali sotirate ali da zmehčate čebulo, zeleno, por itd.
- Z vodo ali osnovo ga uporabite za predgrevanje tekočin za kuhanje.
- Ko preklopite na glavni program, je naprava segreta, in nekatere ali vse sestavine so že v skledi.
- Ob tem vam ni treba pomivati posode, ki bi jo sicer uporabili za pripravo.

PORRIDGE (KAŠA)/RIŽOTA ☁

Z merilno posodico dajte zrnje (riž, oves, ječmen itd.) v skledo.

Porridge (kaša)

- Uporabite lestvico na desni strani notranjosti sklede, ki ima oznake od ½ do 1½.
- Posode ne napolnite nad oznako **max**.

Congee

- Uporabite lestvico na sredini notranjosti sklede, ki ima oznake od 1 do 3.
 - Posode ne napolnite nad oznako **max**.
1. Skledo napolnite z vodo do številke, ki se ujema z uporabljenim številom posodic riža.
 2. Zaprite pokrov.
 3. Z gumbom ? izberite ☁ v meniju.
 4. Izberite čas kuhanja. Privzeti čas je 1 ura.
 5. Gumba za ure in minute lahko uporabljate le, kadar utripa čas na prikazovalniku.
 6. Z gumbom za min izberite možnosti na prikazovalniku (5, 10, 15, 20, 25, 30, 35, 40, 45, 50 in 55).
 7. Z gumbom za h izberite možnosti na prikazovalniku (1, 2, 3 in 4).
 8. Če želite razveljaviti nastavev za 4 uro, znova pritisnite gumb za uro, ko utripa čas na prikazovalniku.
 - Če 2 minuti ne storite ničesar, se naprava preklopi v pripravljenost.
 9. Ta program omogoča uporabo časovnika (glejte ČASOVNIK).
 10. Pritisnite gumb ⬇.
 11. Prikazovalnik začne odštevati.
 12. Ob koncu časa kuhanja se naprava preklopi v način »ohranjanje toplote«. Sveti lučka ☁.
 13. Pritisnite gumb ☁. Odprite pokrov. Odstranite hrano.

Rižota

Sledite receptu v nadaljevanju te knjižice.



PECIVO 🍞

1. Zamrznjeno testo pred uporabo dobro odmrznite.
2. Sklede ne napolnite več kot do polovice.
3. Skledo obrišite z jedilnim oljem.
4. Testo dajte v skledo.
5. Zaprite pokrov.
6. Z gumbom ? izberite 🍞 v meniju.
7. Izberite čas kuhanja. Privzeti čas je 40 minut.
8. Privzeti čas je 40 minut.
9. Gumba za ure in minute lahko uporabljate le, kadar utripa čas na prikazovalniku.
10. Z gumbom za min izberite možnosti na prikazovalniku (5, 10, 15, 20, 25, 30, 35, 40, 45, 50 in 55).
11. Z gumbom za h izberite možnosti na prikazovalniku (1 in 2).
12. Če želite razveljaviti nastavev za 2 uro, znova pritisnite gumb za uro, ko utripa čas na prikazovalniku.
- Če 2 minuti ne storite ničesar, se naprava preklopi v pripravljenost.
13. Ko nastavite čas, pritisnite ⬇.
14. Prikazovalnik začne odštevati.
15. Ob koncu časa kuhanja se naprava preklopi v način »ohranjanje toplote«. Sveti lučka ☁.
16. Za najboljše rezultate hrano odstranite, takoj ko je končana, da se ne bo omočila.











17. Pritisnite gumb . Odprite pokrov. Odstranite hrano.

OHRANJANJE TOPLOTE

Če želite uporabiti funkcijo za ohranjanje toplote po programu, ki je ne podpira, in je edina stvar, ki se prikaže na prikazovalniku, utripajoča lučka , pritisnite .

Za izhod iz te funkcije pritisnite .

ČASOVNIK

- Uporabite lahko časovnik z zamikom, ki je na voljo za programe juha , jogurt , kruh , para  in porridge (kaša) .
 - To storite takoj po nastavitvi časa kuhanja, preden pritisnete start :
1. Pritisnite gumb . Sveti lučka .
 2. Odločite se, kdaj naj bo hrana pripravljena.
 3. Če je zdaj na primer 2.00 in mora biti pripravljena ob 9.00, morate nastaviti 7 ur.
 4. Z gumboma **h** in **min** nastavite ustrezno uro ter minuto.
 5. Pritisnite gumb .

NEGA IN VZDRŽEVANJE







1. Odklopite napravo in pustite, da se ohladi.
2. Vtič odstranite iz električne vtičnice, nato pa odstranite priključek z napajalnega dovoda naprave.
3. Pri zaprtem pokrovu primite zgornji del filtra in ga potegnite iz pokrova (SLIKA A).
4. Obrnite ga, da razkrijete oznake na sprednjem robu.
5. Pokrov filtra dobro primite in obrnite ostali filter proti odprti ključavnici  (SLIKA B).
6. Pritisnite jezičke na dnu notranjega pokrova in jih potegnite z naprave (SLIKA C).
7. Odstranljive dele pomijte ročno.
8. Vse površine obrišite s čisto vlažno krpo.
9. Nobenega od delov naprave ne dajajte v pomivalni stroj.
10. Filter znova sestavite in ga namestite nazaj v pokrov.
11. Znova namestite notranji pokrov v pokrov.









RECIKLIRANJE



Za preprečitev okoljskih in zdravstvenih težav zaradi nevarnih snovi naprav in polnilnih in navadnih baterij, označenih z enim od teh simbolov, ni dovoljeno odstraniti med nesortirane komunalne odpadke. Električne in elektronske izdelke in, kjer velja, tudi polnilne in navadne baterije odstranite na ustreznem uradnem mestu za recikliranje/zbiranje.







RECEPTI







	žlica (15 ml)
	čajna žlička (5 ml)
g	grami
ml	mililitri
	merilna posodica
	steblo/rebro (zelena)
	za dlan
	jajce, srednje (53–73 g)





	ščepec
	šopek
	vejica
	stroki
	pločevinka/konzerva
	kozarec
	vrečka (7 g)
	jajce, veliko (63–73 g)

OGNJENI NEWYORŠKI GOVEJI ČILI

DUŠENJE 





- 450 g govedina za pečenko
- 3  česna, olupljena in drobno nasekljana
- 2  mleta kumina
- 1  kajenska paprika
- 1  dimljena paprika/chipotle v prahu
- 1 zelena paprika
- 1  sol
- 1  bazilikinih listov, grobo nasekljanih



- 1  oljčno olje
- 2 čebula, sesekljana
- 2  čili v prahu
- 2  paradižnikova omaka
- 2  paradižniki
- 1  lovrov list
- 1  črni poper
- 1  fižol



Odprite pokrov. Dodajte olje. V meniju izberite  in pritisnite . Govedino, paradižnik in papriko narežite na gržljaje. Meso popecite in odstavite. Dodajte čebulo, česen in začimbe. Kuhajte, dokler se čebula ne omehča. Dodajte meso. Fižol dajte na stran. Dodajte ostale sestavine. Dvakrat pritisnite , da ustavite program. Zaprite pokrov. Izberite . Fižol dodajte 30 minut pred koncem kuhanja. Če je meso na koncu programa še vedno malo žilavo, dodajte skodelico vode in kuhajte v programu za meso še 30 minut.

MAROŠKI RIBJI TAGINE

RIBE 

- 2  česna, olupljena in drobno nasekljana
- 2  stebelna zelena, drobno narezana
- 1  mleta kumina
- 1  kurkuma
- 120 ml belo vino
- 1  paradižnikov pire
- 675 g riba (polenovka/vahnja/lososa)
- 1 majhen šopek koriandra, drobno nasekljan
- 1 sol in poper
- 1 rdeča paprika, odstranjena semena, drobno narezana

- 1 čebula, sesekljana
- 2 sesekljan paradižnik
- 1  mleti ingver
- 1 cimet v palčki
- 1  harissa v pasti
- 120 ml ribja osnova
- 1 limona
- 1  zelene olive



Koriander dajte na stran. Odprite pokrov. Dodajte ostale sestavine. Zaprite pokrov. V meniju izberite  in pritisnite . Kuhajte, dokler riba ne začne razpadati (od 40 do 60 minut). Dvakrat pritisnite , da ustavite program. Dodajte koriander. Začinite po okusu in postrezite.





Za prilogo priporočamo kuskus.

IRSKA OBARA (IRISH STEW) S CMOKI IZ KOZJEGA SIRA





DUŠENJE 

za obaro:

- 1.8 kg jagnječje pleče (kuhano)
- 250 g panceta
- 950 ml jagnječja osnova
- 1 velika čebula, sesekljana
- 2  stebelna zelena, drobno narezana
- 2  paradižnikov pire





- 1  oljčno olje
- 3  česen (natrt)
- sol in poper
- 2 korenje, seseključano
- 2  rožmarin, drobno narezan
- 1  koruzna moka

za cmoke:

- 100 g samovzhajalna moka
- 1  pecilni prašek
- 1  sol
- 1  posušeni peteršilj
- 1  posušeni timijan
- 1  črni poper

- 50 g loj
- 75 ml voda
- 40 g kozji sir (mehak)
- 1  posušeni majaron

za obaro:

Meso odstranite s kosti. Meso in slanino narežite na gržljaje. Odprite pokrov. V meniju izberite  in pritisnite . Dodajte osnovo. Segrejte do vrenja, med tem mešajte. Dušite 10-30 minut. Osnovo dajte v vrč. Dodajte olje. Dodajte čebulo in pokuhajte do mehkega. Dodajte meso, česen, začimbe in drugo zelenjavo ter kuhajte 5 minut. Dodajte osnovo. Dodajte paradižnikovo kašo. Dvakrat pritisnite , da ustavite program. Zaprite pokrov. Izberite .



za cmoke:

Vse sestavine zmešajte z rokami. Zmes oblikujte v 6 krogel. Počakajte 20 minuti.

na koncu:

S koruzno moko in malo vode v skodelici naredite gladko pasto. 30 minut pred koncem kuhanja odprite pokrov. Pasto vmešajte v obaro. Dodajte cmoke. Zaprite pokrov. Počakajte do konca programa, nato postrezite. Čudovita skleda hrane za razvajanje!

Če nimate kuhane jagnjetine, lahko uporabite surovo, namesto programa za dušenje uporabite program za počasno kuhanje in nadaljujte, ko je čas za cmoke.

DOMAČI JOGURT

JOGURT





1200 ml mleko

100 ml jogurt

možnost z dodanim okusom

50 g zamrznjene mešane poletne jagode

1  med

Odprite pokrov. Dodajte mleko. V meniju izberite  in pritisnite . Mleko naj se greje, dokler ne začne brbotati ob robovih. Dvakrat pritisnite , da ustavite program. Počakajte, da se mleko ohladi na temperaturo od 37 do 45°C. Jogurt vmešajte v mleko. Zmešati jo morate temeljito, sicer bo imel jogurt grudice. Zaprite pokrov. V meniju izberite  in pritisnite . Počakajte do konca programa. Jogurt dajte v hladilnik, da se do konca ohladi. Jagode blago segrejte v ponvi. Dodajte med. Ko začnejo jagode izgubljati obliko, jih odstavite z vročine, pustite, da se ohladijo, in jih zmešajte v jogurt. Če želite jogurt shraniti, morate sterilizirati uporabljene kozarce. Grejte jih v pečici na 100 °C za 10 minut. Jogurt bo v hladilniku ostal uporaben do dva tedna.

LOSOS S PIKANTNO OBLOGO

RIBE

2 lososovi fileji (s kožo)

1  oljčno olje

1  paprika



1  čili v prahu

½  mleta kumina

1  sol in poper

1  mehek rvavi sladkor

1 limona

Zmešajte papriko, čili v prahu, kumino, sladkor, sol in poper. Posujte po filejih lososa. Odprite pokrov. Dodajte olje. V meniju izberite  in pritisnite . Počakajte nekaj minut, da se olje segreje. Dodajte fileje s kožo navzdol. Zaprite pokrov. To je odlična kombinacija kuhanja v pari in pečenja kosov rib, le da dobite hrustljivo kožico. Postrezite s krhlim limone. Čudovit lahek obrok.

ČILI Z ZELENJAVO IN KUSKUSOM

POČASNO KUHANJE

1 rdeča čebula, sesekljana

1  oljčno olje

1 velika čebula, sesekljana

1  masleni fižol

2  česna, olupljena in drobno nasekljana

1  fižol cannellini

1  zeleni čilij jalapeno

1  fižol

1  sesekljan paradižnik

1  mlet koriander

2  mleta kumina

1  paradižnikov pire

850 ml zelenjavna osnova

1  sladkor

2  vroča paradižnikova omaka

2  čili v prahu

120-140 ml kuskus

2  posušen origano

1 rdeča paprika, odstranjena semena, drobno narezana

1 rumena paprika, odstranjena semena, drobno narezana





1 oranžna paprika, odstranjena semena, drobno narezana

porcije:



naribani sir

kisla smetana



majhen šopek koriandra, drobno nasekljan





Odprite pokrov. Dodajte olje. V meniju izberite  in pritisnite . Dodajte čebulo in česen. Kuhajte, dokler se čebula ne omešča. Fižol odcedite in dodajte. Kuskus dajte na stran. Dodajte ostale sestavine. Dvakrat pritisnite , da ustavite program. Zaprite pokrov. Izberite . Kuskus dodajte 30 minut pred koncem kuhanja. Če se je kuhanje že končalo, izberite v meniju  in kuhajte še približno 20 minut. Postrezite v skledi, dodajte za dlan sira, malo kisle smetane in ščepec svežega koriandra. Za klasični vegetarijanski čili izpustite kuskus.

GRAHOVA JUHA S SVINJSKO KRAČO



1150 ml	piščančja osnova
225 g	grah
1 	stebelna zelena, drobno narezana
1 	timijan, drobno sesekljan
1	svinjska krača

POČASNO KUHANJE



1	čebula, drobno sesekljana
1	koren, sesekljan
2 	česen (natrt)
1 	lovorov list
	črni poper

Odprite pokrov. Dodajte osnovo. V meniju izberite  in pritisnite . Segrejte do vrenja, med tem mešajte. Dušite 10-30 minut. Dodajte ostale sestavine. Dvakrat pritisnite , da ustavite program. Zaprite pokrov. Izberite . Počakajte do konca programa. Odstranite svinjsko kračo. Zavrzite kožo in kosti. Razrežite meso na kocke. Zavrzite lovorov list. Grah zmečkajte s hrbtno stranjo lesene kuhalnice. Dodajte meso. Začinite po okusu in postrezite. Nebesa v skledi!

ENOLONČNICA IZ JEŠPRENJA IN FIŽOLA BORLOTTI





1 	oljčno olje
175 g	ješprenj
1 	sesekljan paradižnik
1000 ml	zelenjavna osnova
125 ml	suho rdeče vino

DUŠENJE

1 	fižol borlotti
1	čebula, drobno sesekljana
1 	paradižnikov pire
2 	peteršilj (drobno narezan)
	sol in poper

Porcije:



vročče čilijevo olje (možnost)

Odprite pokrov. V meniju izberite  in pritisnite . Dodajte osnovo. Segrejte do vrenja, med tem mešajte. Dušite 10-30 minut. Osnovo dajte v vrč. Dodajte olje. Dodajte čebulo in pokuhajte do mehkega. Dodajte vino in pustite, da se kuha nekaj minut. Dodajte ješprenj in mešajte, dokler ne začne dobivati vinske barve. Fižol odcedite in dodajte. Dodajte paradižnike. Dodajte osnovo. Dvakrat pritisnite , da ustavite program. Zaprite pokrov. Izberite . 30 minut pred koncem kuhanja odprite pokrov. Preverite količino tekočine v skledi. Po potrebi dodajte 150 ml vročče vode. Zaprite pokrov. Počakajte do konca programa. Postrezite s svežim kruhom z lepo skorjo in brizgom vročega čilijevega olja.

ČOKOLADNI BROWNIE



170 g	neslano maslo
340 g	sladkor
170 g	kakav v prahu
110 g	mlečna čokolada v koščkih

PECIVO

3	 vaniljev izvleček
1 	sol
1 	75 g gladka moka

porcije:



vaniljev sladoled (možnost)

Maslo raztopite v ponvi pri nizki temperaturi. Skledo obložite s omaščeno folijo. V posodi zmešajte stopljeno maslo, sladkor, kakav v prahu, moko, jajca, vaniljo in sol. Vmešajte čokoladne koščke. Testo dajte v folijo v skledi. Zaprite pokrov. V meniju izberite . Čas kuhanja nastavite na 1 uro 30 minut. Pritisnite gumb . Pecivo mora biti trdno po robovih in malo sočno v sredini. Postrezite ga toplega s sladoledom.

V PARI KUHA NE ARTIČOKE

PARA

1 	česna, olupljena in drobno nasekljana	2	artičoke
	vejice zelišč (pehtran, meta, peteršilj, timijan)	1	limona

Narežite limono. Steblo odrežite čisto pri dnu vsake artičoke. Odrežite zgornjo četrtino vsake artičoke. Zavrzite poškodovane liste. Odrezane površine natrite s kosom limone. Rezine limone dajte v košaro. Dodajte vejice zelišč. Dodajte česen. Na vrh dajte artičoko. Skledo napolnite z vodo do številke 2 na lestvici na levi v skledi. Na skledo postavite košaro. Zaprite pokrov. V meniju izberite  in pritisnite . Artičoke so kuhane, ko zlahka odstranite zunanje liste. Postrezite toplo ali hladno z omako vinaigrette. Neverjetno!





BISKVIT S SIRUPOM



PARA 

115 g maslo
100 g sladkor v prahu
175 g samovzhajalna moka
4  zlati sirup

2  
¼  vaniljev izvleček
2  mleko





V skledi stepite jajca. V skledi kremasto umešajte maslo in sladkor. Postopoma dodajte jajca, vaniljo in nato moko. Vmešajte mleko. Namastite ognjevarno posodo velikosti 1200 ml. Sirup dajte na dno ognjevarne posode, zmes pa na vrh. Pokrijte s papirjem za peko in folijo, vrh zavežite z vrstico. Odprite pokrov. Ognjevarno posodo dajte v skledo v napravi. V skledo v napravi dajte toliko vrele vode, da sega 3 cm pod rob ognjevarne posode. Zaprite pokrov. V meniju izberite . Čas kuhanja nastavite na 1 uro 30 minut. Pritisnite gumb . Počakajte do konca programa. Prevrnite na krožnik in postrezite toplo. To je čudovita sladica za celo leto.

PESINA RIŽOTA IZ VEČNAMENSKEGA KUHALNIKA

250 ml belo vino
2  česna, olupljena in drobno nasekljana
1 čebula, drobno sesekljana
1  timijan, drobno sesekljan

na koncu:

100 ml jogurt
1  maslo



Odprite pokrov. V meniju izberite  in pritisnite . Dodajte osnovo. Segrejte do vrenja, med tem mešajte. Dušite 10-30 minut. Osnovo dajte v vrč. Dvakrat pritisnite , da ustavite program. V meniju izberite  in pritisnite . Pustite, da se ogreje. Peso olupite in narežite v kocke velikosti 1 cm. Peso, česen in čebulo dajte v skledo. Kuhajte, dokler se čebula ne omehča. Vmešajte riž. Zaprite pokrov in kuhajte od 3 do 4 minute. Odprite pokrov. Vmešajte vino. Zaprite pokrov in kuhajte od 3 do 4 minute. Odprite pokrov. Dodajte timijan. Dodajte osnovo. Zaprite pokrov. Počakajte do konca programa. Preverite riž – biti mora še vedno čvrst, vendar ne trd. Če še ni čisto kuhan, dodajte malo vode in pustite, da se kuha še nekaj minut. Vmešajte maslo – to daje rižoti sijaj. Postrezite z malo jogurta in potresite s peteršiljem. To je zelo dobra predjed ali lahko kosilo.

PORRIDGE (KAŠA)/RIŽOTA

400 g pesa
2  oljčno olje
250 g riž arborio/za rižoto

1  peteršilj (drobno narezan)

PORRIDGE (KAŠA)

2  ovseni kosmiči
1¼  sol



Porcije:

temnorjavi sladkor



PORRIDGE (KAŠA)/RIŽOTA

voda
2  sladkor

mleko / kislá smetana

Odprite pokrov. Dodajte ovsene kosmiče, sol in sladkor. Skledo napolnite z vodo do oznake 1½ na lestvici na desni v skledi. Zaprite pokrov. V meniju izberite  in pritisnite . Počakajte do konca programa. Postrezite z mlekom ali smetano. Potresite s temnim rjavim sladkorjem. Če želite, lahko 15 minut pred koncem kuhanja dodate nasekljane posušene marelice ali razpolovljene slive (brez koščic). Odvečno porridge lahko hranite največ 2 dni v hladilniku, nato jo pogrejte.

PORRIDGE (KAŠA) Z OREŠČKI

½  ovseni kosmiči
120 ml mleko
1  mleti cimet



Porcije:

zlati sirup

PORRIDGE (KAŠA)/RIŽOTA





voda
3  sušeni kokos

nasekljani mandlji

Odprite pokrov. Dodajte ovsene kosmiče, cimet, kokos in mleko. Skledo napolnite z vodo do oznake ½ na lestvici na desni v skledi. Zaprite pokrov. V meniju izberite  in pritisnite . Počakajte do konca programa. Pokaplajte z zlatim sirupom in potresite z nasekljanimi mandlji.

SLANI RIŽ





RIŽ 





2 	riž		voda
1	jušna kocka (zelenjava)	2	korenje, seseklano
2 	stebelna zelena, drobno narezana	1 	kurkuma
1 	grah (možnost)		
1 	rdeča paprika, odstranjena semena, drobno narezana		

Odprite pokrov. Riž dajte v skledo. Skledo napolnite z vodo do številke 2 na lestvici na levi v skledi. Zdrobite kocko za jušno osnovo in jo vmešajte v vodo. Dodajte ostale sestavine. Zaprite pokrov. Izberite . Počakajte do konca programa, nato postrezite. Če riž še ni povsem kuhan, ga pustite nekaj minut pri zaprtem pokrovu, da se kuha v pari.

KREPKA PARADIŽNIKOVA JUHA





JUHA 





1	čebula, seseklana		
1 	oljčno olje		
1 	sesekljan paradižnik		
2	sesekljan paradižnik		
1	rdeča paprika, odstranjena semena, drobno narezana		
2	krompir		
550 ml	piščančja osnova		
1 	paradižnikov pire		
1 	posušena mešanica zelišč		
1 	črni poper		

Odprite pokrov. Dodajte osnovo. V meniju izberite  in pritisnite . Segrejte do vrenja, med tem mešajte. Dušite 10-30 minut. Osnovo dajte v vrč. Dvakrat pritisnite , da ustavite program. Paradižnik olupite in narežite na kocke. V meniju izberite  in pritisnite . Dodajte olje. Dodajte čebulo in sladko papriko. Kuhajte, dokler se čebula ne omehča. Dodajte osnovo. Dodajte ostale sestavine. Zaprite pokrov. Počakajte do konca programa. Začinite po okusu. Postrezite s skorjastim kruhom.

BELA ŠTRUCA

KRUH 



1 	zlati sirup	1 	maslo
320 ml	mleko	1 	suhi kvas
500 g	močna bela moka za kruh	1 	sol

Odprite pokrov. Dodajte mleko. V meniju izberite  in pritisnite . Mleko naj se greje, dokler ne začne brbotati ob robovih. Mleko dajte v vrč. Dvakrat pritisnite , da ustavite program. Počakajte, da se mleko ohladi na temperaturo od 37 do 45°C. Maslo raztopite v ponvi pri nizki temperaturi. V skledi zmešajte moko in sol. Dodajte kvas, maslo in sirup. Dodajte mleko in zgnetite v kroglu. Če je zmes zelo lepljiva, dodajte več moke. Pokrijte in pustite 10 minut na toplem. Znova pregnetite. Pokrijte in pustite 10 minut na toplem. Odprite pokrov. V meniju izberite  in pritisnite . Zaprite pokrov. 30 minut pred koncem kuhanja odprite pokrov. Kruh obrnite. S tem bo dobil vrh štruce nekaj barve in hrustljivo skorjo. Počakajte do konca programa. Postrezite z maslom v tankih rezinah.

KRUH S SODO



KRUH 



1 	zmes za kruh s sodo		maslo
350 ml	voda		





Odprite pokrov. Skledo namastite z maslom. V meniju izberite . Zaprite pokrov. Čas kuhanja nastavite na 2 uri 15 minut. Pritisnite gumb . Pustite, da se ogreje. Zmes za kruh s sodo dajte v skledo. Dodajte vodo. Z roko zmešajte v kroglu. Odprite pokrov. Testo dajte v skledo. Testo z lopatko iz umetne mase razdelite na četrtine. Zaprite pokrov. 30 minut pred koncem kuhanja odprite pokrov. Kruh obrnite. S tem bo dobil vrh štruce nekaj barve in hrustljivo skorjo. Počakajte do konca programa. Ohladite na rešetki. Postrezite s slanin maslom, samostojno ali kot prilogo.

JUHA S CHORIZO, ZELJEM IN JABOLKI

JUHA



¼	klobasa chorizo, fino nasekljana
1	jabolko
2 	stebelna zelena, drobno narezana
¼	mlado zelje, fino nasekljana
2 	česna, olupljena in drobno nasekljana
1 	sol
850 ml	zelenjavna osnova





1	čebula, drobno sesekljana
2	korenje, sesekljano
2	sesekljan paradižnik
1 	paradižnikov pire
1 	kajenska paprika
1 	črni poper



Odprite pokrov. V meniju izberite  in pritisnite . Chorizo sotirajte 2 minuti. Dodajte čebulo in česen. Kuhajte, dokler se čebula ne omehča. Jabolko olupite, odstranite peške in razrežite. Dodajte ostale sestavine. Dvakrat pritisnite , da ustavite program. Zaprite pokrov. V meniju izberite  in pritisnite . Počakajte do konca programa. To je odlična juha, če pa jo čez noč pustite v hladilniku, se okus še razvije.

PIŠČANEC S PARADIŽNIKI IN GOBAMI

MESO

2	piščančje prsi, brez kože in kosti
450 g	jurčki, sesekljani
2 	česna, olupljena in drobno nasekljana
1 	worcestrska omaka
	sol in poper



1 	oljčno olje
1 	sesekljan paradižnik
1 	paradižnikova omaka
1 	posušen origano



Odprite pokrov. V meniju izberite  in pritisnite . Dodajte olje. Piščančje prsi začinite s soljo in poprom ter jih dajte v skledo. Meso obrnite, da zapečete obe strani. Dodajte česen in gobe. Kuhajte od 3 do 4 minute, piščanca enkrat obrnite. Dodajte paradižnik, Worcestrsko omako, paradižnikovo omako in origano. Kuhajte naprej in piščanca še enkrat obrnite. Preverite, ali je piščanec skuhan. Postrezite s testeninami, krompirjem ali rižem. To je hiter in okusen obrok s sestavinami, ki jih imajo v vsaki trgovini.

V STOUTU PEČENA REBRA Z JAVOROM IN SOJO

MESO



1 kg	svinjska rebra
350 ml	Guinness/stout
140 ml	goveja/svinjska osnova
3 	česna, olupljena in drobno nasekljana





1	čebula, sesekljana
1 	oljčno olje
60 ml	javorjev sirup / med
2 	temna sojina omaka





Odprite pokrov. V meniju izberite . Dodajte olje. Čas kuhanja nastavite na 1 uro 45 minut. Pritisnite gumb . Dodajte rebra in jih pecite 5 minut, občasno jih obrnite. Odstranite rebra. Dodajte čebulo in česen. Kuhajte, dokler se čebula ne omehča. Rebra vrnite v skledo. Vmešajte Guinness, jušno osnovo, javorjev sirup in sojino omako. Zaprite pokrov. Počakajte do konca programa. Začinite po okusu in postrezite. Enkratna predjed ali del mešanega kosila.

ENOLONČNICA Z GOVEJIMI PRSI

POČASNO KUHANJE

1 kg	goveje prsi
2 	česna, olupljena in drobno nasekljana
50 g	klobasa chorizo, narezana
2	rdeča čebula, sesekljana
600 ml	goveja osnova
2 	posušena mešanica zelišč
6-8	krompir (majhen)
2 	worcestrska omaka

2 	paradižnikov pire
2 	lovorov list
2	korenje
3 	zelena
2 	rožmarin, drobno narezan
1 	sesekljan paradižnik
	sol in poper

Krompirja ne olupite. Krompir, korenje in zelena narežite na koščke. Prsi začinite s soljo in poprom. Odprite pokrov. V meniju izberite  in pritisnite . Dodajte osnovo. Segrejte do vrenja, med tem mešajte. Dušite 10-30 minut. Osnovo dajte v vrč. Chorizo sotirajte 2 minuti. Dodajte meso. V celoti popecite. Dodajte čebulo, česen, krompir, zeleno in korenje. Če imate kakršno koli drugo korenasto zelenjavo, ki jo je treba porabiti, jo dodajte. Kuhajte, dokler se čebula ne omehča. Dodajte osnovo. Dodajte ostale sestavine. Dvakrat pritisnite , da ustavite program. Izberite . Počakajte do konca programa, nato postrezite. Kuhajte do 8 ur, vendar bo verjetno pripravljeno po približno 5 urah.

Διαβάστε τις οδηγίες, φυλάξτε τις σε ασφαλές μέρος και σε περίπτωση που δώσετε τη συσκευή σε άλλον χρήστη, δώστε μαζί και τις οδηγίες. Αφαιρέστε όλα τα υλικά συσκευασίας πριν από τη χρήση.

ΣΗΜΑΝΤΙΚΑ ΜΕΤΡΑ ΑΣΦΑΛΕΙΑΣ



Τηρείτε τα βασικά μέτρα ασφάλειας, συμπεριλαμβανομένων των παρακάτω:

Η παρούσα συσκευή μπορεί να χρησιμοποιηθεί από παιδιά ηλικίας άνω των 8 ετών και άτομα με μειωμένες σωματικές, αισθητήριες ή διανοητικές ικανότητες ή άτομα που δεν διαθέτουν επαρκή εμπειρία ή γνώση, υπό την προϋπόθεση ότι θα βρίσκονται υπό επίβλεψη ή θα λάβουν σχετικές οδηγίες και κατανοούν τους κινδύνους που ενέχει η χρήση της συσκευής.

Τα παιδιά δεν πρέπει να χρησιμοποιούν τη συσκευή ως παιχνίδι. Ο καθαρισμός και η συντήρηση από χρήστη δεν πρέπει να

πραγματοποιούνται από παιδιά, εκτός κι αν είναι άνω των 8 ετών και βρίσκονται υπό επίβλεψη. Να διατηρείτε τη συσκευή και το καλώδιο μακριά από παιδιά ηλικίας κάτω των 8 ετών.

Αν ο σύνδεσμος ή το καλώδιο υποστούν βλάβη, πρέπει να αντικατασταθούν από ειδικό σύστημα που διατίθεται από τον κατασκευαστή ή τον αντιπρόσωπο σέρβις.

-  Μην χρησιμοποιείτε αυτή τη συσκευή κοντά σε μπανιέρες, ντουζιέρες, νιπτήρες ή άλλα δοχεία που περιέχουν νερό.
-  Σε περίπτωση κακής χρήσης της συσκευής μπορεί να προκληθεί τραυματισμός.
-  Οι επιφάνειες της συσκευής θερμαίνονται υπερβολικά. Οι επιφάνειες θα συνεχίσουν να καίνε και μετά από τη χρήση λόγω της υπολειπόμενης θερμότητας.
 - Μη βάζετε κατεψυγμένο κρέας ή πουλερικά μέσα στη συσκευή – να ξεπαγώνετε πλήρως το κρέας πριν το χρησιμοποιήσετε.
 - Να ψήνετε το κρέας, τα πουλερικά, καθώς και τα παράγωγά τους (κιμάς, μπιφτέκια κ.λπ.) έως ότου να εξαχθούν όλοι οι χυμοί τους. Να ψήνετε το ψάρι έως ότου να ροδίσουν όλες οι πλευρές του.
 - Μην προσπαθήσετε να μαγειρέψετε οτιδήποτε μέσα στο σώμα του βραστήρα – να μαγειρεύετε μόνο μέσα στον αφαιρούμενο κάδο.
 - Μην υπερβείτε την ένδειξη μέγιστης πλήρωσης (max).
 - Μην καλύπτετε τη συσκευή ή τοποθετείτε τίποτα πάνω σε αυτή.
 - Αφαιρέστε το βύσμα από την πρίζα του ρεύματος, έπειτα αφαιρέστε το σύνδεσμο από την είσοδο ισχύος στη συσκευή.
 - Να αποσυνδέετε τη συσκευή από το ρεύμα όταν δεν τη χρησιμοποιείτε.
 - Μη χρησιμοποιείτε εξαρτήματα διαφορετικά από αυτά που παρέχονται από την εταιρεία μας.
 - Μη χρησιμοποιείτε τη συσκευή για οποιονδήποτε σκοπό πέραν αυτού που περιγράφεται στις παρούσες οδηγίες.
 - Μη χρησιμοποιείτε τη συσκευή εάν είναι φθαρμένη ή παρουσιάζει δυσλειτουργίες.

ΑΠΟΚΛΕΙΣΤΙΚΑ ΓΙΑ ΟΙΚΙΑΚΗ ΧΡΗΣΗ





ΣΧΕΔΙΑ

- | | |
|----------------------|----------------------|
| 1. Πίνακας ελέγχου | 5. Φλιτζάνι μέτρησης |
| 2. Καπάκι | 6. Καλάθι |
| 3. Ασφάλεια καπακιού | 7. Μπολ |
| 4. Εσωτερικό καπάκι | 8. Σύνδεσμος |
-



ΠΡΟΕΤΟΙΜΑΣΙΑ

1. Τοποθετήστε τη συσκευή σε σταθερή, πυράντοχη επιφάνεια.
 2. Μην χρησιμοποιείτε τη συσκευή κοντά ή κάτω από κουρτίνες, ράφια, ντουλάπια, ή οτιδήποτε άλλο θα μπορούσε να φθαρεί από τον διαφεύγοντα ατμό.
 3. Μετά από το μαγείρεμα να πιάνετε τον κάδο με γάντια φούρνου (ή με πανί) και να το ακουμπάτε σε θερμάντοχη επιφάνεια ή σε πιατέλα.
 4. Βάλτε τον κάδο μέσα στον βραστήρα.
 5. Στρέψτε τον κάδο λίγο αριστερά-δεξιά ούτως ώστε ο πάτος του κάδου να κάνει καλή επαφή με την αντίσταση.
-

ΡΥΖΙ



1. Χρησιμοποιήστε το φλιτζάνι μέτρησης για να βάλετε το ρύζι μέσα στο μπολ.
 2. Μην χρησιμοποιήσετε περισσότερα από 10 φλιτζάνια ρύζι.
 3. Χρησιμοποιήστε την κλίμακα στα αριστερά, στο εσωτερικό του μπολ, η οποία φέρει ενδείξεις από το 2 έως το 10
 4. Γεμίστε το μπολ με νερό έως τον αριθμό που αντιστοιχεί στον αριθμό των φλιτζανιών ρυζιού που χρησιμοποιούνται.
 5. Κλείστε το καπάκι.
 6. Πατήστε το κουμπί . Το κουμπί θα ανάψει.
 7. Τα εξωτερικά τμήματα της οθόνης θα αναβοσβήνουν όσο το φαγητό ζεσταίνεται.
 8. Η οθόνη στη συνέχεια θα αναγράφει τον υπολειπόμενο χρόνο μαγειρέματος (13 λεπτά), και θα κάνει αντίστροφη μέτρηση.
 9. Στο τέλος του χρόνου μαγειρέματος, η συσκευή θα μπει σε λειτουργία «διατήρησης θερμοκρασίας». Θα ανάψει η ένδειξη .
 10. Ανοίξτε το καπάκι.
 11. Σηκώστε τον κάδο και τοποθετήστε τον σε θερμάντοχη επιφάνεια ή σε πιατέλα.
 12. Πατήστε το κουμπί .
 13. Με την σπάτουλα ανασηκώστε και ανακατέψτε το ρύζι για να φύγει όλος ο ατμός.
 14. Μερικές φορές το στρώμα του ρυζιού που ακουμπάει στον κάδο σχηματίζει κρούστα.
 15. Αν δεν τη θέλετε, μπορείτε να την αφαιρέσετε με τη σπάτουλα αφού σερβίρετε το ρύζι.
-

ΑΡΓΟ ΜΑΓΕΙΡΕΜΑ





1. Τσιγάρισμα κρέατος και λαχανικών (βλ. «ΤΣΙΓΑΡΙΣΜΑ/ΣΟΤΑΡΙΣΜΑ/ΜΑΛΑΚΩΜΑ/ΒΡΑΣΙΜΟ»).
 2. Βράστε το υγρό μαγειρέματος (βλ. «ΤΣΙΓΑΡΙΣΜΑ/ΣΟΤΑΡΙΣΜΑ/ΜΑΛΑΚΩΜΑ/ΒΡΑΣΙΜΟ»).
 3. Τοποθετήστε τα στερεά υλικά μέσα στο μπολ, μετά προσθέστε το υγρό μαγειρέματος.
 4. Κλείστε το καπάκι.
 5. Πατήστε το κουμπί . Το κουμπί θα ανάψει.
 6. Η οθόνη θα δείχνει 8 ώρες, και θα αρχίσει την αντίστροφη μέτρηση.
 7. Στο τέλος του χρόνου μαγειρέματος, η συσκευή θα μπει σε λειτουργία «διατήρησης θερμοκρασίας». Θα ανάψει η ένδειξη .
 8. Πατήστε το κουμπί . Ανοίξτε το καπάκι. Αφαιρέστε το φαγητό.
-

ΨΗΣΙΜΟ



1. Τσιγάρισμα κρέατος και λαχανικών (βλ. «ΤΣΙΓΑΡΙΣΜΑ/ΣΟΤΑΡΙΣΜΑ/ΜΑΛΑΚΩΜΑ/ΒΡΑΣΙΜΟ»).
2. Βράστε το υγρό μαγειρέματος (βλ. «ΤΣΙΓΑΡΙΣΜΑ/ΣΟΤΑΡΙΣΜΑ/ΜΑΛΑΚΩΜΑ/ΒΡΑΣΙΜΟ»).

3. Τοποθετήστε τα στερεά υλικά μέσα στο μπολ, μετά προσθέστε το υγρό μαγειρέματος.
4. Κλείστε το καπάκι.
5. Πατήστε το κουμπί . Το κουμπί θα ανάψει.
6. Η οθόνη θα δείχνει 1 ώρα, και θα αρχίσει την αντίστροφη μέτρηση.
7. Στο τέλος του χρόνου μαγειρέματος, η συσκευή θα μπει σε λειτουργία «διατήρησης θερμοκρασίας». Θα ανάψει η ένδειξη .
8. Πατήστε το κουμπί . Ανοίξτε το καπάκι. Αφαιρέστε το φαγητό.



ΚΡΕΑΣ

1. Πασπαλίστε το τρόφιμο με λάδι μαγειρικής.
2. Πασπαλίστε την επιφάνεια του τροφίμου με μυρωδικά.
3. Προσθέστε μια κουταλιά της σούπας λάδι μαγειρικής στο μπολ.
4. Βάλτε το φαγητό μέσα στο μπολ.
5. Κλείστε το καπάκι.
6. Ο χρόνος εξαρτάται από το μέγεθος του τροφίμου.
7. Η ποσότητα του φαγητού που μαγειρεύετε κάθε φορά να μην υπερβαίνει τα 500g.
8. Συνιστούμε χρόνους μαγειρέματος 10 λεπτών + 10 λεπτά ανά 100g βάρους για το βοδινό.
9. Μη μαγειρεύετε χοιρινό ή πουλερικά για λιγότερο από 5, 10, 15, 20, 25, 30 λεπτά.
10. Χρησιμοποιήστε το κουμπί  για να επιλέξετε το  στο μενού.
11. Επιλέξτε τον χρόνο μαγειρέματος. Ο προεπιλεγμένος χρόνος είναι 20 λεπτά.
12. Μπορείτε να χρησιμοποιήσετε μόνο τα κουμπιά h (ώρα) και min (λεπτά) όσο αναβοσβήνει η ώρα της οθόνης.
13. Χρησιμοποιήστε το κουμπί min (λεπτά) για να μεταφέρετε την οθόνη στις διάφορες επιλογές (10, 15, 20, 25, 5, 10, 15, 20, 25, 30, 35, 40, 45, 50 και 55).
14. Αν θέλετε να μαγειρέψετε για 1 ώρα, πατήστε το κουμπί h (ώρα).
15. Για να αναιρέσετε τον ορισμό 1 ώρας, πατήστε ξανά το κουμπί h, όσο η ώρα της οθόνης αναβοσβήνει.
 - Αν δεν κάνετε κάτι για 2 λεπτά, η συσκευή επανέρχεται σε κατάσταση αναμονής.
16. Όταν ορίσετε την ώρα, πατήστε .
17. Η οθόνη θα αρχίσει την αντίστροφη μέτρηση.
18. Στο τέλος του χρόνου μαγειρέματος, η συσκευή θα μπει σε λειτουργία «διατήρησης θερμοκρασίας». Θα ανάψει η ένδειξη .
19. Πατήστε το κουμπί . Ανοίξτε το καπάκι. Αφαιρέστε το φαγητό.

ΣΟΥΠΑ

1. Τσιγάρισμα κρέατος και λαχανικών (βλ. «ΤΣΙΓΑΡΙΣΜΑ/ΣΟΤΑΡΙΣΜΑ/ΜΑΛΑΚΩΜΑ/ΒΡΑΣΙΜΟ»).
2. Τοποθετήστε τα στερεά υλικά μέσα στο μπολ, μετά προσθέστε το υγρό μαγειρέματος.
3. Κλείστε το καπάκι.
4. Χρησιμοποιήστε το κουμπί  για να επιλέξετε το  στο μενού.
5. Επιλέξτε τον χρόνο μαγειρέματος. Ο προεπιλεγμένος χρόνος είναι 1 ώρα.
6. Μπορείτε να χρησιμοποιήσετε μόνο τα κουμπιά h (ώρα) και min (λεπτά) όσο αναβοσβήνει η ώρα της οθόνης.
7. Χρησιμοποιήστε το κουμπί min (λεπτά) για να μεταφέρετε την οθόνη στις διάφορες επιλογές (10, 15, 20, 25, 5, 10, 15, 20, 25, 30, 35, 40, 45, 50 και 55).
8. Χρησιμοποιήστε το κουμπί h (λεπτά) για να μεταφέρετε την οθόνη στις διάφορες επιλογές (1, 2, 3, 4 και 5).
9. Για να αναιρέσετε τον ορισμό 5 ώρας, πατήστε ξανά το κουμπί h, όσο η ώρα της οθόνης αναβοσβήνει.
 - Αν δεν κάνετε κάτι για 2 λεπτά, η συσκευή επανέρχεται σε κατάσταση αναμονής.
10. Έχετε την επιλογή να χρησιμοποιήσετε τον χρονοδιακόπτη με αυτό το πρόγραμμα (βλ. ΧΡΟΝΟΔΙΑΚΟΠΤΗΣ).
11. Πατήστε το κουμπί .



12. Η οθόνη θα αρχίσει την αντίστροφη μέτρηση.
13. Στο τέλος του χρόνου μαγειρέματος, η συσκευή θα μπει σε λειτουργία «διατήρησης θερμοκρασίας». Θα ανάψει η ένδειξη .
14. Πατήστε το κουμπί . Ανοίξτε το καπάκι. Αφαιρέστε το φαγητό.

ΓΙΑΟΥΡΤΙ

Καλλιέργεια γιαουρτιού

Μπορείτε να χρησιμοποιήσετε 5, 10, 15, 20, 25, 30ml (2 κουταλιές της σούπας):

- Ζωντανό γιαούρτι χωρίς γέυση – πρέπει να είναι φρέσκο (αναζητήστε μακρινή ημερομηνία λήξεως). Κάθε μάρκα δίνει διαφορετικά αποτελέσματα.

Γιαούρτι που φτιάξατε προηγούμενα.

- Τα βακτήρια εξασθενούν με το πέρασμα του χρόνου, και έτσι αυτό μπορεί να γίνει 10 φορές προτού χρησιμοποιήσετε νέα καλλιέργεια.





Λυοφιλισμένη καλλιέργεια γιαουρτιού από φαρμακείο ή κατάστημα με είδη υγιεινής διατροφής

- Αν οι οδηγίες στη συσκευασία της καλλιέργειας διαφέρουν από αυτές στον οδηγό, εφαρμόστε τις οδηγίες της συσκευασίας.





Γάλα

- Θα χρειαστείτε 1 λίτρο γάλα.
- Με το πλήρες γάλα φτιάχνεται πιο πηχτό γιαούρτι σε σχέση με το γάλα με χαμηλά λιπαρά.
- Για να το κάνετε ακόμα πιο πηχτό, μπορείτε να προσθέσετε στο υγρό γάλα έως 8 κουταλιές της σούπας γάλα σε σκόνη.
- Μπορείτε, ακόμα, να χρησιμοποιήσετε ομογενοποιημένο γάλα σε σκόνη ή γάλα εβαπορέ.





Παρασκευή γιαουρτιού

1. Θα πρέπει να εξοντώσετε τα βακτήρια που περιέχονται στο γάλα, για να τα εμποδίσετε να ανταγωνιστούν τα βακτήρια στην καλλιέργεια του γιαουρτιού.
2. Όσο ζεσταίνετε το γάλα, αφήστε την καλλιέργεια γιαουρτιού να πάρει τη θερμοκρασία δωματίου.
3. Ανοίξτε το καπάκι.
4. Χρησιμοποιήστε το πρόγραμμα ΣΤΟΝ ΑΤΜΟ (ΤΣΙΓΑΡΙΣΜΑ/ΣΟΤΑΡΙΣΜΑ/ΜΑΛΑΚΩΜΑ/ΒΡΑΣΙΜΟ) για να ζεστάνετε το γάλα σε θερμοκρασία λίγο πριν τη βράση.
5. Αφήστε το γάλα να ζεσταθεί μέχρι να αρχίσει να κάνει φυσαλίδες στα άκρα.
6. Αφήστε το γάλα να κρυώσει μέχρι να φτάσει θερμοκρασία μεταξύ 37°C και 45°C.
7. Ανακατέψτε την καλλιέργεια γιαουρτιού μέσα στο γάλα.
8. Θα πρέπει να ανακατευθούν καλά, αλλιώς το γιαούρτι θα σβολιάσει.
9. Κλείστε το καπάκι.
10. Χρησιμοποιήστε το κουμπί  για να επιλέξετε το  στο μενού.
11. Επιλέξτε τον χρόνο μαγειρέματος. Ο προεπιλεγμένος χρόνος είναι 8 ώρες.
12. Μπορείτε να χρησιμοποιήσετε μόνο τα κουμπιά h (ώρα) και min (λεπτά) όσο αναβοσβήνει η ώρα της οθόνης.
13. Χρησιμοποιήστε το κουμπί min (λεπτά) για να μεταφέρετε την οθόνη στις διάφορες επιλογές (10, 15, 20, 25, 5, 10, 15, 20, 25, 30, 35, 40, 45, 50 και 55).
14. Χρησιμοποιήστε το κουμπί h (λεπτά) για να μεταφέρετε την οθόνη στις διάφορες επιλογές (6, 7, 8, 9 και 10).
15. Για να αναιρέσετε τον ορισμό 10 ώρας, πατήστε ξανά το κουμπί h, όσο η ώρα της οθόνης αναβοσβήνει.
 - Αν δεν κάνετε κάτι για 2 λεπτά, η συσκευή επανέρχεται σε κατάσταση αναμονής.
16. Έχετε την επιλογή να χρησιμοποιήσετε τον χρονοδιακόπτη με αυτό το πρόγραμμα (βλ. ΧΡΟΝΟΔΙΑΚΟΠΤΗΣ).
17. Πατήστε το κουμπί .
18. Η οθόνη θα αρχίσει την αντίστροφη μέτρηση.
19. Στο τέλος του χρόνου μαγειρέματος, η συσκευή θα μπει σε λειτουργία αναμονής.
20. Δε θα διατηρήσει ζεστό το γιαούρτι.
21. Πατήστε το κουμπί . Ανοίξτε το καπάκι. Αφαιρέστε το φαγητό.

ΨΩΜΙ

1. Ξεπαγάστε πλήρως την παγωμένη ζύμη πριν την χρησιμοποιήσετε.
2. Η ποσότητα του φαγητού που μαγειρεύετε κάθε φορά να μην υπερβαίνει τα 500g.
3. Λαδώστε το μπολ με λάδι μαγειρικής.
4. Βάλτε τη ζύμη μέσα στο μπολ.
5. Κλείστε το καπάκι.
6. Χρησιμοποιήστε το κουμπί  για να επιλέξετε το  στο μενού.
7. Επιλέξτε τον χρόνο μαγειρέματος. Ο προεπιλεγμένος χρόνος είναι 3 ώρες.
8. Μπορείτε να χρησιμοποιήσετε μόνο τα κουμπιά h (ώρα) και min (λεπτά) όσο αναβοσβήνει η ώρα της οθόνης.
9. Χρησιμοποιήστε το κουμπί min (λεπτά) για να μεταφέρετε την οθόνη στις διάφορες επιλογές (10, 15, 20, 25, 5, 10, 15, 20, 25, 30, 35, 40, 45, 50 και 55).
10. Χρησιμοποιήστε το κουμπί h (λεπτά) για να μεταφέρετε την οθόνη στις διάφορες επιλογές (1, 2, 3, 4, 5 και 6).
11. Για να ανατρέξετε τον ορισμό 6 ώρας, πατήστε ξανά το κουμπί h, όσο η ώρα της οθόνης αναβοσβήνει.
 - Αν δεν κάνετε κάτι για 2 λεπτά, η συσκευή επανέρχεται σε κατάσταση αναμονής.
12. Έχετε την επιλογή να χρησιμοποιήσετε τον χρονοδιακόπτη με αυτό το πρόγραμμα (βλ. ΧΡΟΝΟΔΙΑΚΟΠΤΗΣ).
13. Πατήστε το κουμπί .
14. Η οθόνη θα αρχίσει την αντίστροφη μέτρηση.
15. Στο τέλος του χρόνου μαγειρέματος, η συσκευή θα μπει σε λειτουργία «διατήρησης θερμοκρασίας». Θα ανάψει η ένδειξη .
16. Πατήστε το κουμπί . Ανοίξτε το καπάκι. Αφαιρέστε το φαγητό.

ΨΑΡΙ

1. Πασπαλίστε το τρόφιμο με λάδι μαγειρικής.
2. Πασπαλίστε την επιφάνεια του τροφίμου με μυρωδικά.
3. Προσθέστε μια κουταλιά της σούπας λάδι μαγειρικής στο μπολ.
4. Βάλτε το φαγητό μέσα στο μπολ.
5. Κλείστε το καπάκι.
6. Ο χρόνος εξαρτάται από το μέγεθος του τροφίμου.
7. Η ποσότητα του φαγητού που μαγειρεύετε κάθε φορά να μην υπερβαίνει τα 500g.
8. Συνιστούμε χρόνους μαγειρέματος 10 λεπτών ανά 100g βάρους.
9. Χρησιμοποιήστε το κουμπί  για να επιλέξετε το  στο μενού.
10. Επιλέξτε τον χρόνο μαγειρέματος. Ο προεπιλεγμένος χρόνος είναι 20 λεπτά.
11. Μπορείτε να χρησιμοποιήσετε μόνο τα κουμπιά h (ώρα) και min (λεπτά) όσο αναβοσβήνει η ώρα της οθόνης.
12. Χρησιμοποιήστε το κουμπί min (λεπτά) για να μεταφέρετε την οθόνη στις διάφορες επιλογές (10, 15, 20, 25, 5, 10, 15, 20, 25, 30, 35, 40, 45, 50 και 55).
13. Αν θέλετε να μαγειρέψετε για 1 ώρα, πατήστε το κουμπί h (ώρα).
14. Για να ανατρέξετε τον ορισμό 1 ώρας, πατήστε ξανά το κουμπί h, όσο η ώρα της οθόνης αναβοσβήνει.
 - Αν δεν κάνετε κάτι για 2 λεπτά, η συσκευή επανέρχεται σε κατάσταση αναμονής.
15. Όταν ορίσετε την ώρα, πατήστε .
16. Η οθόνη θα αρχίσει την αντίστροφη μέτρηση.
17. Στο τέλος του χρόνου μαγειρέματος, η συσκευή θα μπει σε λειτουργία «διατήρησης θερμοκρασίας». Θα ανάψει η ένδειξη .
18. Το ιδανικό είναι να αφαιρείτε το φαγητό αμέσως μόλις μαγειρεύεται, για να μην σας ξεραθεί.
19. Πατήστε το κουμπί . Ανοίξτε το καπάκι. Αφαιρέστε το φαγητό.



ΣΤΟΝ ΑΤΜΟ ☁

1. Γεμίστε το μπολ με κρύο νερό μέχρι την ένδειξη 6.
 2. Βάλτε το καλάθι πάνω από τον κάδο και τοποθετήστε το φαγητό μέσα στο καλάθι.
 3. Για ομοιόμορφο μαγείρεμα, κόβετε όλα τα τρόφιμα σε κομμάτια με περίπου το ίδιο μέγεθος.
 4. Για αρακά, ή οτιδήποτε μπορεί να σκάσει ή να πέσει μέσα στο νερό, φτιάξτε ένα πουγκί με αλουμινόχαρτο
 5. Να αφαιρείτε προσεκτικά το πουγκί – να φοράτε γάντια φούρνου και να χρησιμοποιείτε πλαστική λαβίδα/κουτάλα.
 6. Κλείστε το καπάκι.
 7. Χρησιμοποιήστε το κουμπί ⏸ για να επιλέξετε το ⏸ στο μενού.
 8. Επιλέξτε τον χρόνο μαγειρέματος. Ο προεπιλεγμένος χρόνος είναι 30 λεπτά.
- Αυτά θα πρέπει να μαγειρεύονται εντός του προεπιλεγμένου χρόνου:

Τρόφιμα (νωπά)	Ποσότητα
Φασολάκια	200g
Λαχανάκια βρυξελλών	200g
Καρότα (φέτες)	200g
Πατάτες (τέταρτα)	400g
Μπρόκολο	200g
Λάχανο	τέταρτο
Κότσαλα καλαμποκιού	2

9. Μπορείτε να χρησιμοποιήσετε μόνο τα κουμπιά h (ώρα) και min (λεπτά) όσο αναβοσβήνει η ώρα της οθόνης.
 10. Χρησιμοποιήστε το κουμπί min (λεπτά) για να μεταφέρετε την οθόνη στις διάφορες επιλογές (5, 10, 15, 20, 25, 30, 35, 40, 45, 50 και 55).
 11. Χρησιμοποιήστε το κουμπί h (λεπτά) για να μεταφέρετε την οθόνη στις διάφορες επιλογές (1 και 2).
 12. Για να αναιρέσετε τον ορισμό 2 ώρας, πατήστε ξανά το κουμπί h, όσο η ώρα της οθόνης αναβοσβήνει.
- Αν δεν κάνετε κάτι για 2 λεπτά, η συσκευή επανέρχεται σε κατάσταση αναμονής.
13. Έχετε την επιλογή να χρησιμοποιήσετε τον χρονοδιακόπτη με αυτό το πρόγραμμα (βλ. ΧΡΟΝΟΔΙΑΚΟΠΤΗΣ).
 14. Πατήστε το κουμπί ⏸.
 15. Η οθόνη θα αρχίσει την αντίστροφη μέτρηση.
 16. Στο τέλος του χρόνου μαγειρέματος, η συσκευή θα μπει σε λειτουργία «διατήρησης θερμοκρασίας». Θα ανάψει η ένδειξη 🔥.
 17. Το ιδανικό είναι να αφαιρέτε το φαγητό αμέσως μόλις μαγειρεύεται, για να μην σας λασπώσει.
 18. Πατήστε το κουμπί ⏸. Ανοίξτε το καπάκι. Αφαιρέστε το φαγητό.

ΤΣΙΓΑΡΙΣΜΑ/ΣΟΤΑΡΙΣΜΑ/ΜΑΛΑΚΩΜΑ/ΒΡΑΣΙΜΟ

1. Μπορείτε να χρησιμοποιήσετε το πρόγραμμα ΣΤΟΝ ΑΤΜΟ ☁ στην προεπιλεγμένη του ρύθμιση, με το καπάκι ανοιχτό, ως σκεύος υψηλής θερμοκρασίας για 5, 10, 15, 20, 25, 30 λεπτά, πριν από το μαγείρεμα με άλλο πρόγραμμα.
2. Χρησιμοποιήστε το με λίγο λάδι για να τσιγαρίσετε κρέας και λαχανικά, για σοτάρισμα, για να μαλακώσετε κρεμμύδια, σέλινο, πράσα, κλπ.
3. Χρησιμοποιήστε το με νερό ή ζωμό για να προθερμάνετε υγρά μαγειρέματος.
4. Όταν μεταφέρετε στο κύριο πρόγραμμα, η συσκευή έχει ζεσταθεί, και μερικά ή και όλα τα υλικά σας βρίσκονται ήδη μέσα στο μπολ.
5. Δε χρειάζεται, λοιπόν, να πλύνετε το σκεύος που θα είχατε χρησιμοποιήσει κατά την προετοιμασία.





ΧΥΛΟΣ ΒΡΩΜΗΣ/ΡΙΖΟΤΟ

Χρησιμοποιήστε το φλιτζάνι μέτρησης για να βάλετε τους σπόρους (ρύζι, βρώμη, σίκαλη, κλπ.) μέσα στο μπολ.

Χυλός βρώμης

- Χρησιμοποιήστε την κλίμακα στα δεξιά, στο εσωτερικό του μπολ, η οποία φέρει ενδείξεις από ½ έως 1½.
- Μην υπερβαίνετε την ένδειξη μέγιστης πλήρωσης (**max**).



χυλός ρυζιού

- Χρησιμοποιήστε την κλίμακα στο κέντρο, στο εσωτερικό του μπολ, η οποία φέρει ενδείξεις από το 1 έως το 3
 - Μην υπερβαίνετε την ένδειξη μέγιστης πλήρωσης (**max**).
1. Γεμίστε το μπολ με νερό έως τον αριθμό που αντιστοιχεί στον αριθμό των φλιτζανιών σπόρων.
 2. Κλείστε το καπάκι.
 3. Χρησιμοποιήστε το κουμπί  για να επιλέξετε το  στο μενού.
 4. Επιλέξτε τον χρόνο μαγειρέματος. Ο προεπιλεγμένος χρόνος είναι 1 ώρα.
 5. Μπορείτε να χρησιμοποιήσετε μόνο τα κουμπιά h (ώρα) και min (λεπτά) όσο αναβοσβήνει η ώρα της οθόνης.
 6. Χρησιμοποιήστε το κουμπί min (λεπτά) για να μεταφέρετε την οθόνη στις διάφορες επιλογές (5, 10, 15, 20, 25, 30, 35, 40, 45, 50 και 55).
 7. Χρησιμοποιήστε το κουμπί h (λεπτά) για να μεταφέρετε την οθόνη στις διάφορες επιλογές (1, 2, 3 και 4).
 8. Για να αναφέρετε τον ορισμό 4 ώρας, πατήστε ξανά το κουμπί h, όσο η ώρα της οθόνης αναβοσβήνει.
 - Αν δεν κάνετε κάτι για 2 λεπτά, η συσκευή επανέρχεται σε κατάσταση αναμονής.
 9. Έχετε την επιλογή να χρησιμοποιήσετε τον χρονοδιακόπτη με αυτό το πρόγραμμα (βλ. ΧΡΟΝΟΔΙΑΚΟΠΤΗΣ).
 10. Πατήστε το κουμπί .
 11. Η οθόνη θα αρχίσει την αντίστροφη μέτρηση.
 12. Στο τέλος του χρόνου μαγειρέματος, η συσκευή θα μπει σε λειτουργία «διατήρησης θερμοκρασίας». Θα ανάψει η ένδειξη .
 13. Πατήστε το κουμπί . Ανοίξτε το καπάκι. Αφαιρέστε το φαγητό.



Ριζότο

Ακολουθήστε τη συνταγή που εμφανίζεται παρακάτω στο βιβλιαράκι.



ΚΕΙΚ

1. Ξεπαγώστε πλήρως την παγωμένη ζύμη πριν την χρησιμοποιήσετε.
2. Μη γεμίζετε το μπολ πάνω από το μισό περίπου.
3. Λαδώστε το μπολ με λάδι μαγειρικής.
4. Βάλτε τη ζύμη μέσα στο μπολ.
5. Κλείστε το καπάκι.
6. Χρησιμοποιήστε το κουμπί  για να επιλέξετε το  στο μενού.
7. Επιλέξτε τον χρόνο μαγειρέματος. Ο προεπιλεγμένος χρόνος είναι 40 λεπτά.
8. Ο προεπιλεγμένος χρόνος είναι 40 λεπτά.
9. Μπορείτε να χρησιμοποιήσετε μόνο τα κουμπιά h (ώρα) και min (λεπτά) όσο αναβοσβήνει η ώρα της οθόνης.
10. Χρησιμοποιήστε το κουμπί min (λεπτά) για να μεταφέρετε την οθόνη στις διάφορες επιλογές (5, 10, 15, 20, 25, 30, 35, 40, 45, 50 και 55).
11. Χρησιμοποιήστε το κουμπί h (λεπτά) για να μεταφέρετε την οθόνη στις διάφορες επιλογές (1 και 2).
12. Για να αναφέρετε τον ορισμό 2 ώρας, πατήστε ξανά το κουμπί h, όσο η ώρα της οθόνης αναβοσβήνει.
 - Αν δεν κάνετε κάτι για 2 λεπτά, η συσκευή επανέρχεται σε κατάσταση αναμονής.
13. Όταν ορίσετε την ώρα, πατήστε .
14. Η οθόνη θα αρχίσει την αντίστροφη μέτρηση.











15. Στο τέλος του χρόνου μαγειρέματος, η συσκευή θα μπει σε λειτουργία «διατήρησης θερμοκρασίας». Θα ανάψει η ένδειξη .
16. Το ιδανικό είναι να αφαιρέετε το φαγητό αμέσως μόλις μαγειρεύεται, για να μην σας λασπώσει.
17. Πατήστε το κουμπί . Ανοίξτε το καπάκι. Αφαιρέστε το φαγητό.

ΔΙΑΤΗΡΗΣΗ ΘΕΡΜΟΚΡΑΣΙΑΣ

- Αν θέλετε να χρησιμοποιήσετε τη δυνατότητα διατήρησης θερμοκρασίας μετά από πρόγραμμα που δεν την υποστηρίζει, τότε, όταν το μόνο πράγμα που αναγράφεται στην οθόνη είναι η λυχνία  που αναβοσβήνει, πατήστε .
- Πατήστε  για έξοδο από αυτή τη δυνατότητα.

Ο ΧΡΟΝΟΔΙΑΚΟΠΤΗΣ

- Μπορείτε να χρησιμοποιήσετε τον χρονοδιακόπτη καθυστέρησης με τα προγράμματα σούπα , γιαούρτι , ψωμί , ατμός  και χυλός βρώμης .
- Αυτό πρέπει να το κάνετε αμέσως μετά τη ρύθμιση του χρόνου μαγειρέματος και πριν πατήσετε το κουμπί έναρξης :
 1. Πατήστε το κουμπί . Θα ανάψει η ένδειξη .
 2. Αποφασίστε τότε θέλετε να είναι έτοιμο το φαγητό.
 3. Για παράδειγμα, αν η ώρα τώρα είναι 2:00, και θέλετε να είναι έτοιμο στις 9:00, πρέπει να ορίσετε τον χρόνο σε 7 ώρες.
 4. Χρησιμοποιήστε τα κουμπιά **h** (ώρες) και **min** (λεπτά) για να ρυθμίσετε την ώρα.
 5. Πατήστε το κουμπί .

ΦΡΟΝΤΙΔΑ ΚΑΙ ΣΥΝΤΗΡΗΣΗ







1. Βγάλτε το βύσμα της συσκευής από την πρίζα και αφήστε την να κρυώσει.
2. Αφαιρέστε το βύσμα από την πρίζα του ρεύματος, έπειτα αφαιρέστε το σύνδεσμο από την είσοδο ισχύος στη συσκευή.
3. Με το καπάκι κλειστό, πιάστε το πάνω τμήμα του φίλτρου και βγάλτε το έξω από το καπάκι (ΕΙΚ. Α).
4. Γυρίστε το ανάποδα, για να αποκαλυφθούν οι ενδείξεις στην μπροστινή άκρη.
5. Κρατήστε καλά το καπάκι του φίλτρου, και γυρίστε το υπόλοιπο φίλτρο προς τα κάτω για να ανοίξετε το λουκέτο . (ΕΙΚ. Β).
6. Πιέστε τις εξοχές στο κάτω τμήμα του εσωτερικού καπακιού, και τραβήξτε το για να το αφαιρέσετε από τη συσκευή (ΕΙΚ. C).
7. Πλύνετε τα αποσπώμενα εξαρτήματα στο χέρι.
8. Σκουπίστε όλες τις επιφάνειες με ένα καθαρό βρεγμένο πανί.
9. Μην τοποθετήσετε οποιοδήποτε εξάρτημα της συσκευής σε πλυντήριο πιάτων.
10. Συναρμολογήστε ξανά το φίλτρο, και τοποθετήστε το ξανά μέσα στο καπάκι.
11. Τοποθετήστε ξανά το εσωτερικό καπάκι μέσα στο καπάκι.









ΑΝΑΚΥΚΛΩΣΗ







Για την αποφυγή προβλημάτων στο περιβάλλον και την υγεία λόγω επιβλαβών ουσιών, οι συσκευές και οι επαναφορτιζόμενες και μη επαναφορτιζόμενες μπαταρίες που επισημαίνονται με κάποιο από αυτά τα σύμβολα, δεν πρέπει να απορρίπτονται με τα κοινά οικιακά απορρίμματα. Να απορρίπτετε πάντα τις ηλεκτρικές και ηλεκτρονικές συσκευές και, όπου χρειάζεται, τις επαναφορτιζόμενες και μη επαναφορτιζόμενες μπαταρίες, σε κατάλληλο, επίσημο σημείο συλλογής/ανακύκλωσης.

ΣΥΝΤΑΓΕΣ

	κουταλιά της σούπας (15 ml)
	κουταλάκι του γλυκού (5 ml)
g	γραμμάρια
ml	χιλιοστόλιτρα
	φλιτζάνι μέτρησης
	κλαράκι (σέλινο)
	χούφτα
	αβγό, μέτριο (53-63 γρ)

	πρέζα
	ματσάκι
	κλαδάκι
	σκελίδα(ες)
	κονσέρβα
	βάζο
	φακελάκι (7g)
	αβγό, μεγάλο (63-73 γρ)











ΤΣΙΛΙ ΜΕ ΛΑΧΑΝΙΚΑ ΚΑΙ ΚΟΥΣΚΟΥΣ

1	κόκκινο κρεμμύδι, ψιλοκομμένο
1	μεγάλο κρεμμύδι, ψιλοκομμένο
2 	σκόρδο, ξεφλουδισμένο και κομμένο
1	κόκκινη πιπεριά, ξεσποριασμένη και κομμένη
1	κίτρινη πιπεριά, ξεσποριασμένη και κομμένη
1 	τριμμένο κόλιαντρο
1 	πολτός τομάτας
850 ml	κοτόπουλου/ λαχανικών
2 	ζεστή σάλτσα ντομάτας
120-140 ml	κουσκούς
1	πορτοκαλί πιπεριά, ξεσποριασμένη και κομμένη





για να σερβίρετε:

τυρί τριμμένο
μικρό ματσάκι κόλιαντρο, ψιλοκομμένο

ΑΡΓΟ ΜΑΓΕΙΡΕΜΑ

1 	ελαιόλαδο
1 	φασόλια
1 	φασόλια cannellini
1 	πράσινη πιπεριά χαλαπένιος
1 	φασόλια
2 	τριμμένο κύμινο
1 	ζάχαρη
2 	πιπεριά τσίλι σε σκόνη
2 	αποξηραμένη ρίγανη
1 	ψιλοκομμένες ντομάτες

ξινή κρέμα

Ανοίξτε το καπάκι. Προσθέστε το λάδι. Επιλέξτε το  στο μενού, και μετά πατήστε . Προσθέστε το κρεμμύδι και το σκόρδο. Περιμένετε μέχρι να μαλακώσουν τα κρεμμύδια. Στραγγίξτε τα φασόλια και προσθέστε τα. Κρατήστε στην άκρη το κουσκούς. Προσθέστε τα υπόλοιπα υλικά. Πατήστε το  δύο φορές για να διακόψετε το πρόγραμμα. Κλείστε το καπάκι. Επιλέξτε . Προσθέστε το κουσκούς 30 λεπτά πριν από τη λήξη του μαγειρέματος. Αν το μαγείρεμα έχει ήδη τελειώσει, επιλέξτε  στο μενού και μαγειρέψτε για περίπου 20 λεπτά ακόμα. Σερβίρετε σε μπολ με μια χούφτα ψαριού, πασπαλιζετε με ξινή κρέμα και λίγο φρέσκο κόλιαντρο. Για το κλασικό χορτοφαγικό τσίλι, παραλείπετε το κουσκούς.

ΣΠΙΤΙΚΟ ΓΙΑΟΥΡΤΙ





1200 ml γάλα

επιλογή γεύσης

50 g κατεψυγμένα ανάμεικτα καλοκαιρινά μούρα

100 ml γιαούρτι

1  μέλι





Ανοίξτε το καπάκι. Προσθέστε το γάλα. Επιλέξτε το  στο μενού, και μετά πατήστε . Αφήστε το γάλα να ζεσταθεί μέχρι να αρχίσει να κάνει φυσαλίδες στα άκρα. Πατήστε το  δύο φορές για να διακόψετε το πρόγραμμα. Αφήστε το γάλα να κρυώσει μέχρι να φτάσει θερμοκρασία μεταξύ 37°C και 45°C. Ανακατέψτε το γιαούρτι μέσα στο γάλα. Θα πρέπει να ανακατευθούν καλά, αλλιώς το γιαούρτι θα σβολιάσει. Κλείστε το καπάκι. Επιλέξτε το  στο μενού, και μετά πατήστε . Περιμένετε μέχρι να τελειώσει το πρόγραμμα. Βάλτε το γιαούρτι στο ψυγείο για να παγώσει καλά. Ζεστάνετε τα μούρα ελαφρώς στο τηγάνι. Προσθέστε το μέλι. Όταν τα μούρα αρχίζουν να λιώνουν, κατεβάστε τα από τη φωτιά, περιμένετε να κρυώσουν και μετά αναμειξτε τα με το γιαούρτι. Αν θέλετε να αποθηκεύσετε το γιαούρτι, θα πρέπει να αποστειρώσετε τα βάζα που σκοπεύετε να χρησιμοποιήσετε. Ζεστάνετε τα στο φούρνο στους 100°C για 10 λεπτά. Το γιαούρτι θα διατηρηθεί έως και για 2 εβδομάδες στο ψυγείο.





ΓΙΑΟΥΡΤΙ



ΣΟΥΠΑ ΜΕ ΜΠΙΖΕΛΙΑ ΣΠΑΣΤΑ ΚΑΙ ΧΟΙΡΙΝΟ ΚΟΤΣΙ







ΑΡΓΟ ΜΑΓΕΙΡΕΜΑ



1150 ml	ζωμός κοτόπουλου	1	κρεμμύδι, ψιλοκομμένο
225 g	μπιζέλια σπαστά	1	καρότο, κομμένο
1 	ένα κοτσάνι σέλινο, κομμένο	2 	σκόρδο (λιωμένο)
1 	θυμάρι, ψιλοκομμένο	1 	φύλλο δάφνης
1	χοιρινό κότσι		μαύρο πιπέρι

Ανοίξτε το καπάκι. Προσθέστε το ζωμό. Επιλέξτε το  στο μενού, και μετά πατήστε . Ανακατέψτε μέχρι να βράσει. Σιγοβράστε για 10 λεπτά. Προσθέστε τα υπόλοιπα υλικά. Πατήστε το  δύο φορές για να διακόψετε το πρόγραμμα. Κλείστε το καπάκι. Επιλέξτε . Περιμένετε μέχρι να τελειώσει το πρόγραμμα. Αφαιρέστε το χοιρινό κότσι. Πετάξτε τις πέτσες και τα κόκαλα. Κόψτε το κρέας σε κυβάκια. Πετάξτε το φύλλο της δάφνης. Λιώστε τα σπαστά μπιζέλια με την πίσω πλευρά μιας ξύλινης κουτάλας. Προσθέστε το κρέας. Προσθέστε μπαχαρικά κατά προτίμηση και σερβίρετε. Ο παράδεισος σε μπολ!

ΣΟΛΟΜΟΣ ΜΕ ΠΙΚΑΝΤΙΚΗ ΕΠΑΛΕΙΨΗ

ΨΑΡΙ







2	φιλέτα σολομού (με την πέτσα)	1 	ελαιόλαδο
1 	πάπρικα	1 	πιπεριά τσίλι σε σκόνη
½ 	τριμμένο κύμινο	1 	αλάτι και πιπέρι
1 	μαλακή καστανή ζάχαρη	1	λεμόνι

Αναμείξτε την πάπρικα, τη σκόνη του τσίλι, το κύμινο, τη ζάχαρη, το αλάτι και το πιπέρι. Πασπαλίστε τα φιλέτα του σολομού. Ανοίξτε το καπάκι. Προσθέστε το λάδι. Επιλέξτε το  στο μενού, και μετά πατήστε . Περιμένετε μερικά λεπτά για να κάψει το λάδι. Προσθέστε τα φιλέτα με τη πέτσα προς τα κάτω. Κλείστε το καπάκι. Έτσι στα κομμάτια ψαριού συνδυάζεται εξαιρετα το βράσιμο στον ατμό και το τηγάνισμα και απολαμβάνετε την τραγανή πέτσα. Σερβίρετε με μια φέτα λεμόνι. Ένα υπέροχο ελαφρύ γεύμα.







IRISH STEW (ΙΡΛΑΝΔΙΚΟ ΡΑΓΟΥ) ΜΕ ΝΤΑΜΠΛΙΝΓΚ ΜΕ ΓΕΜΙΣΗ ΓΙΔΟΥΤΥΡΙ

ΨΗΤΟ





για το ραγού:

1.8 kg	αρνίσια σπάλα (μαγειρεμένη)	1 	ελαιόλαδο
250 g	μπέικον	3 	σκόρδο (λιωμένο)
950 ml	ζωμός αρνιού		αλάτι και πιπέρι
1	μεγάλο κρεμμύδι, ψιλοκομμένο	2	καρότα, κομμένα
2 	ένα κοτσάνι σέλινο, κομμένο	2 	δενδρολίβανο, ψιλοκομμένο
2 	πολτός τομάτας	1 	κορν φλάουρ

για τα ντάμπλινγκ:

100 g	αλεύρι που φουσκώνει μόνο του	1 	baking powder
50 g	λίπος	1 	αλάτι
75 ml	νερό	1 	αποξηραμένος μαιντανός
40 g	γιδούτυρι (μαλακό)	1 	αποξηραμένο θυμάρι
1 	αποξηραμένη μαντζουράνα	1 	μαύρο πιπέρι

για το ραγού:

Αφαιρέστε το κρέας από το κόκκαλο. Κόψτε το κρέας και το μπέικον σε μέγεθος μπουκιάς. Ανοίξτε το καπάκι. Επιλέξτε το  στο μενού, και μετά πατήστε . Προσθέστε το ζωμό. Ανακατέψτε μέχρι να βράσει. Σιγοβράστε για 10 λεπτά. Μεταφέρετε το ζωμό σε κανάτα. Προσθέστε το λάδι. Προσθέστε το κρεμμύδι και σοτάρητέ το έως ότου να μαλακώσει. Προσθέστε το κρέας, το σκόρδο, τα μυρωδικά και τα υπόλοιπα λαχανικά και μαγειρέψτε για 5 λεπτά. Προσθέστε το ζωμό. Προσθέστε τον πουρέ τομάτας. Πατήστε το  δύο φορές για να διακόψετε το πρόγραμμα. Κλείστε το καπάκι. Επιλέξτε .

για τα ντάμπλινγκ:

Ανακατέψτε όλα τα υλικά με το χέρι. Χωρίστε το μείγμα σε 6 μπάλες. Αφήστε το μείγμα να ξεκουραστεί για 20 λεπτά.

για να ολοκληρώσετε:

Φτιάξτε μια ρευστή κρέμα με το κορν φλάουρ και λίγο νερό σε ένα φλιτζάνι. 30 λεπτά πριν λήξει το μαγείρεμα, ανοίξτε το καπάκι. Ανακατέψτε την κρέμα μέσα στο ραγού. Προσθέστε τα ντάμπλινγκ. Κλείστε το καπάκι. Περιμένετε μέχρι να τελειώσει το πρόγραμμα, έπειτα σερβίρετε. Ένα εκπληκτικό μπουλ πρόχειρου φαγητού!

- Αν δεν έχετε μαγειρεμένο αρνί, μπορείτε να χρησιμοποιήσετε ωμό, με το πρόγραμμα αργού μαγειρέματος αντί για το πρόγραμμα ψησίματος, και μετά να συνεχίσετε από το σημείο με τα ντάμπλινγκ.

ΠΥΡΙΝΟ ΒΟΔΙΝΟ ΤΣΙΛΙ ΤΗΣ ΝΕΑΣ ΥΟΡΚΗΣ



450 g	τσιγαρισμένο βοδινό	1 🍴	ελαιόλαδο
3 🍷	σκόρδο, ξεφλουδισμένο και κομμένο	2	κρεμμύδια, κομμένα
2 🍴	τριμμένο κύμινο	2 🍴	πιπεριά τσίλι σε σκόνη
1 🍴	πιπέρι καγιέν	2 🍴	σάλτσα ντομάτας
1 🍴	καπνιστή πάπρικα/σκόνη τσιπότλε	2 🍷	ντομάτες
1	πράσινη πιπεριά	1 🍷	φύλλο δάφνης
1 🍴	αλάτι	1 🍴	μαύρο πιπέρι
1 🍷	φύλλα βασιλικού, χοντροκομμένα	1 🍷	φασόλια

Ανοίξτε το καπάκι. Προσθέστε το λάδι. Επιλέξτε το 🍷 στο μενού, και μετά πατήστε ⏏. Ψιλοκόψτε το βοδινό, τις ντομάτες και την πιπεριά σε μέγεθος μπουκιές. Τσιγαρίστε το κρέας, μετά τραβήξτε το από τη φωτιά. Προσθέστε τα κρεμμύδια, το σκόρδο και όλα τα μυρωδικά. Περιμένετε μέχρι να μαλακώσουν τα κρεμμύδια. Προσθέστε το κρέας. Κρατήστε στην άκρη τα φασόλια. Προσθέστε τα υπόλοιπα υλικά. Πατήστε το 🍷 δύο φορές για να διακόψετε το πρόγραμμα. Κλείστε το καπάκι. Επιλέξτε 🍷. Προσθέστε τα φασόλια 30 λεπτά πριν από τη λήξη του μαγειρέματος. Αν το κρέας κρατάει λιγάκι ακόμα όταν λήξει το πρόγραμμα, προσθέστε ένα φλιτζάνι νερό και εκτελέστε το πρόγραμμα κρέατος για άλλα 30 λεπτά ακόμα.

ΜΑΡΟΚΙΝΟ ΨΑΡΙ ΤΑΤΖΙΝ



2 🍷	σκόρδο, ξεφλουδισμένο και κομμένο	1	κρεμμύδι, ψιλοκομμένο
1	κόκκινη πιπεριά, ξεσποριασμένη και κομμένη	2 🍴	ένα κοτσάνι σέλινο, κομμένο
2	ψιλοκομμένες ντομάτες	1 🍴	τριμμένο κύμινο
1 🍴	τριμμένη πιπερόριζα	1 🍴	κουρκούμη
1	ένα ξυλάκι κανέλλα	1 🍴	πάστα χαρίσα
120 ml	λευκό κρασί	1 🍴	πολτός τομάτας
120 ml	ζωμός ψαριού	1	λεμόνι
1	μικρό ματσάκι κόλιαντρο, ψιλοκομμένο	1 🍷	πράσινες ελιές
	αλάτι και πιπέρι		
675 g	ψάρι (βακαλαός Ατλαντικού/μελανόγραμμα/σολομού)		

Κρατήστε στην άκρη το κόλιαντρο. Ανοίξτε το καπάκι. Προσθέστε τα υπόλοιπα υλικά. Κλείστε το καπάκι. Επιλέξτε το 🍷 στο μενού, και μετά πατήστε ⏏. Μαγειρέψτε μέχρι το ψάρι να αρχίζει να ξεφλουδίζει (40-60 λεπτά). Πατήστε το 🍷 δύο φορές για να διακόψετε το πρόγραμμα. Προσθέστε το κόλιαντρο. Προσθέστε μπαχαρικά κατά προτίμηση και σερβίρετε. Η συνταγή συνδυάζεται υπέροχα με κουσκούς.

ΓΕΥΜΑ ΤΟΥΡΛΟΥ ΜΕ ΑΠΟΦΛΟΙΩΜΕΝΟ ΚΡΙΘΑΡΙ ΚΑΙ ΦΑΣΟΛΙΑ BORLOTTI



1 🍴	ελαιόλαδο	1 🍷	φασόλια Borlotti
175 g	αποφλοιωμένο κριθάρι	1	κρεμμύδι, ψιλοκομμένο
1 🍷	ψιλοκομμένες ντομάτες	1 🍴	πολτός τομάτας
1000 ml	κοτόπουλου/ λαχανικών	2 🍷	δυόσμος (ψιλοκομμένος)
125 ml	κόκκινο ξηρό κρασί		αλάτι και πιπέρι

για να σερβίρετε:

λάδι καυτού τσίλι (προαιρετικά)

Ανοίξτε το καπάκι. Επιλέξτε το ☰ στο μενού, και μετά πατήστε ⏏. Προσθέστε το ζωμό. Ανακατέψτε μέχρι να βράσει. Σιγοβράστε για 10 λεπτά. Μεταφέρετε το ζωμό σε κανάτα. Προσθέστε το λάδι. Προσθέστε το κρεμμύδι και σotáρετέ το έως ότου να μαλακώσει. Προσθέστε το κρασί και μαγειρέψτε για λίγα λεπτά. Προσθέστε το αποφλοιωμένο κριθάρι και ανακατέψτε μέχρι να αρχίζει να παίρνει το χρώμα του κρασιού. Στραγγίξτε τα φασόλια και προσθέστε τα. Προσθέστε τις ντομάτες. Προσθέστε το ζωμό. Πατήστε το ☑ δύο φορές για να διακόψετε το πρόγραμμα. Κλείστε το καπάκι. Επιλέξτε ☺. 30 λεπτά πριν λήξει το μαγείρεμα, ανοίξτε το καπάκι. Ελέγξτε την ποσότητα του υγρού μέσα στο μπολ. Αν χρειαστεί, προσθέστε 150ml καυτό νερό. Κλείστε το καπάκι. Περιμένετε μέχρι να τελειώσει το πρόγραμμα. Σερβίρετε με φρέσκο τραγανό ψωμί και μια δόση λαδιού από καυτό τοίλι.

ΛΕΥΚΗ ΦΡΑΝΤΖΟΛΑ

ΨΩΜΙ 🍞

1 🍷 σιρόπι μελάσας golden
320 ml γάλα
500 g αλεύρι σκληρό για λευκό ψωμί

1 🍷 βούτυρο
1 📏 αποξηραμένη μαγιά
1 🍷 αλάτι

Ανοίξτε το καπάκι. Προσθέστε το γάλα. Επιλέξτε το ☰ στο μενού, και μετά πατήστε ⏏. Αφήστε το γάλα να ζεσταθεί μέχρι να αρχίσει να κάνει φυσαλίδες στα άκρα. Μεταφέρετε το γάλα σε κανάτα. Πατήστε το ☑ δύο φορές για να διακόψετε το πρόγραμμα. Αφήστε το γάλα να κρυώσει μέχρι να φτάσει θερμοκρασία μεταξύ 37°C και 45°C. Λιώστε το βούτυρο σε κατσαρολάκι σε χαμηλή φωτιά. Αναμείξτε το αλεύρι και το αλάτι μέσα σε ένα μπολ. Προσθέστε τη μαγιά, το βούτυρο και το σιρόπι. Προσθέστε το γάλα και ζυμώστε το μείγμα σε σχήμα μπάλας. Αν το μείγμα κολλάει πολύ, προσθέστε λίγο ακόμα αλεύρι. Σκεπάστε το και αφήστε το σε ένα ζεστό χώρο για 10 λεπτά. Ζυμώστε ξανά. Σκεπάστε το και αφήστε το σε ένα ζεστό χώρο για 10 λεπτά. Ανοίξτε το καπάκι. Επιλέξτε το 🍷 στο μενού, και μετά πατήστε ⏏. Κλείστε το καπάκι. 30 λεπτά πριν λήξει το μαγείρεμα, ανοίξτε το καπάκι. Γυρίστε το ψωμί ανάποδα. Έτσι η επάνω μεριά της φραντζόλας θα πάρει λίγο χρώμα και θα γίνει τραγανή. Περιμένετε μέχρι να τελειώσει το πρόγραμμα. Σερβίρετε με άφθονο βούτυρο.

ΨΩΜΙ ΜΕ ΣΟΔΑ

ΨΩΜΙ 🍞

1 📏 μείγμα για ψωμί με σόδα
350 ml νερό

βούτυρο

Ανοίξτε το καπάκι. Βουτυρώστε το μπολ. Επιλέξτε 🍷 στο μενού. Κλείστε το καπάκι. Ρυθμίστε τον χρόνο μαγειρέματος σε 2 ώρες και 15 λεπτά. Πατήστε το κουμπί ⏏. Αφήστε το να ζεσταθεί. Ρίξτε το μείγμα για ψωμί με σόδα σε ένα μπολ. Προσθέστε το νερό. Αναμείξτε με το χέρι σε σχήμα μπάλας. Ανοίξτε το καπάκι. Βάλτε τη ζύμη μέσα στο μπολ. Χωρίστε τη ζύμη σε τέταρτα με μια πλαστική σπάτουλα. Κλείστε το καπάκι. 30 λεπτά πριν λήξει το μαγείρεμα, ανοίξτε το καπάκι. Γυρίστε το ψωμί ανάποδα. Έτσι η επάνω μεριά της φραντζόλας θα πάρει λίγο χρώμα και θα γίνει τραγανή. Περιμένετε μέχρι να τελειώσει το πρόγραμμα. Αφήστε να κρυώσουν σε σχάρα. Σερβίρετε με αλατισμένο βούτυρο σκέτο ή ως συνοδευτικό γεύματος.

ΑΓΚΙΝΑΡΑ ΣΤΟΝ ΑΤΜΟ

ΑΤΜΟΣ 🌫

1 🍷 σκόρδο, ξεφλουδισμένο και κομμένο
κλαδάκια μυρωδικών (εστραγκόν, μέντα, δυόσμος, θυμάρι)

2 αγκινάρες
1 λεμόνι

Κόψτε το λεμόνι σε φέτες. Κόψτε το κοτσάνι σύριζα στη βάση κάθε αγκινάρας. Κόψτε το επάνω τέταρτο κάθε αγκινάρας. Πεταίξτε τυχόν μαραμένα φύλλα. Τρίψτε τις κομμένες επιφάνειες με μια φρέτα λεμόνι. Βάλτε τις φέτες του λεμονιού μέσα στο καλάθι. Προσθέστε τα κλαδάκια των μυρωδικών. Προσθέστε το σκόρδο. Βάλτε την αγκινάρα από πάνω. Γεμίστε με νερό έως το επίπεδο 2 στην κλίμακα προς τα αριστερά, στο εσωτερικό του μπολ. Βάλτε το καλάθι πάνω από το μπολ. Κλείστε το καπάκι. Επιλέξτε το ☰ στο μενού, και μετά πατήστε ⏏. Οι αγκινάρες είναι έτοιμες όταν τα εξωτερικά φύλλα κόβονται εύκολα. Σερβίρετε ζεστό ή κρύο με σος βινεγκρέτ. Απίθανο!

ΥΓΡΟ ΚΕΪΚ ΣΟΚΟΛΑΤΑΣ



ΚΕΪΚ 🍰

170 g ανάλαιο βούτυρο
340 g ζάχαρη
170 g σκόνη κακάο
110 g σταγόνες σοκολάτας γάλακτος

3 🕒
1 🍷 άρωμα βανίλιας
1 🍷 αλάτι
75 g αλεύρι

για να σερβίρετε:



παγωτό βανίλιας (προαιρετικά)

Λιώστε το βούτυρο σε κατσαρολάκι σε χαμηλή φωτιά. Στρώστε βουτυρωμένο φύλλο στα τοιχώματα του μπολ. Χτυπήστε με το σύρμα το λιωμένο βούτυρο, τη ζάχαρη, τη σκόνη κακάο, το αλεύρι, τα αυγά, τη βανίλια και το αλάτι σε ένα πιάτο. Προσθέστε τις σταγόνες σοκολάτας και αναμείξτε. Βάλτε τη ζύμη στο φύλλο μέσα στο μπολ. Κλείστε το καπάκι. Επιλέξτε  στο μενού. Ρυθμίστε τον χρόνο μαγειρέματος σε 1 ώρα και 30 λεπτά. Πατήστε το κουμπί . Το κέικ θα πρέπει να είναι σκληρό εξωτερικά και ελαφρώς κολλώδες στο κέντρο. Σερβίρετε το κέικ ζεστό, με γαρνιτούρα παγωτό.

ΑΦΡΑΤΗ ΠΟΥΤΙΓΚΑ ΜΕ ΣΙΡΟΠΙ

ΑΤΜΟΣ 





115 g	βούτυρο	2	
100 g	λεπτή ζάχαρη	¼	☞ άρωμα βανίλιας
175 g	αλεύρι που φουσκώνει μόνο του	2	☞ γάλα
4	☞ σιρόπι μελάσας golden		

Χτυπήστε τα αυγά σε ένα μπολ. Χτυπήστε το βούτυρο και τη ζάχαρη μέσα στο μπολ. Προσθέστε σταδιακά τα αυγά, κατόπιν τη βανίλια, και ύστερα το αλεύρι. Προσθέστε ανακατεύοντας το γάλα. Λαδώστε ένα πυρίμαχο μπολ 1200ml Ρίξτε το σιρόπι στη βάση του πυρίμαχου μπολ και ρίξτε το μείγμα από πάνω. Καλύψτε με χαρτί ψησίματος και μετά με αλουμινοχαρτο και στερεώστε το επάνω μέρος με σπάγγο. Ανοίξτε το καπάκι. Βάλτε το πυρίμαχο μπολ μέσα στο μπολ στο εσωτερικό της συσκευής. Προσθέστε αρκετό βραστό νερό μέσα στο μπολ στο εσωτερικό της συσκευής ώστε να φτάσει 3cm κάτω από το επάνω τμήμα του πυρίμαχου μπολ. Κλείστε το καπάκι. Επιλέξτε  στο μενού. Ρυθμίστε τον χρόνο μαγειρέματος σε 1 ώρα και 30 λεπτά. Πατήστε το κουμπί . Περιμένετε μέχρι να τελειώσει το πρόγραμμα. Αναποδογυρίστε σε ένα πιάτο και σερβίρετε ζεστό. Μια υπέροχη πουτίγκα για κάθε εποχή του χρόνου!

ΜΕΓΑΛΗ ΝΤΟΜΑΤΟΣΟΥΠΑ



ΣΟΥΠΑ 





1	κρεμμύδι, ψιλοκομμένο	1	☞ ελαιόλαδο
1	 ψιλοκομμένες ντομάτες	2	ψιλοκομμένες ντομάτες
1	κόκκινη πιπεριά, ξεσποριασμένη και κομμένη	2	πατάτες
550 ml	ζωμός κοτόπουλου	1	☞ πολτός τομάτας
1	☞ ανάμεικτα αποξηραμένα βότανα	1	☞ μαύρο πιπέρι

Ανοίξτε το καπάκι. Προσθέστε το ζωμό. Επιλέξτε το  στο μενού, και μετά πατήστε . Ανακατέψτε μέχρι να βράσει. Σιγοβράστε για 10 λεπτά. Μεταφέρετε το ζωμό σε κανάτα. Πατήστε το  δύο φορές για να διακόψετε το πρόγραμμα. Ξεφλουδίστε τις πατάτες και κόψτε τις σε κυβάκια. Επιλέξτε το  στο μενού, και μετά πατήστε . Προσθέστε το λάδι. Προσθέστε το κρεμμύδι και τη γλυκιά πιπεριά. Περιμένετε μέχρι να μαλακώσουν τα κρεμμύδια. Προσθέστε το ζωμό. Προσθέστε τα υπόλοιπα υλικά. Κλείστε το καπάκι. Περιμένετε μέχρι να τελειώσει το πρόγραμμα. Προσθέστε καρυκεύματα κατά προτίμηση. Σερβίρετε με τραγανό ψωμί.

ΣΟΥΠΑ ΜΕ ΤΣΟΡΙΘΟ, ΛΑΧΑΝΟ ΚΑΙ ΜΗΛΟ

ΣΟΥΠΑ 

¼	λουκάνικο τσορίθο, ψιλοκομμένο	1	κρεμμύδι, ψιλοκομμένο
1	μήλο	2	καρότα, κομμένα
2	☞ ένα κοτσάνι σέλινο, κομμένο	2	ψιλοκομμένες ντομάτες
¼	λάχανο, ψιλοκομμένο	1	☞ πολτός τομάτας
2	☞ σκόρδο, ξεφλουδισμένο και κομμένο	1	☞ πιπέρι καγιέν
1	 αλάτι	1	 μαύρο πιπέρι
850 ml	κοτόπουλου/ λαχανικών		

Ανοίξτε το καπάκι. Επιλέξτε το  στο μενού, και μετά πατήστε . Τσιγαρίστε το τσορίθο για 2 λεπτά. Προσθέστε το κρεμμύδι και το σκόρδο. Περιμένετε μέχρι να μαλακώσουν τα κρεμμύδια. Ξεφλουδίστε το μήλο, αφαιρέστε το κουκούτσι και κόψτε το σε κομμάτια. Προσθέστε τα υπόλοιπα υλικά. Πατήστε το  δύο φορές για να διακόψετε το πρόγραμμα. Κλείστε το καπάκι. Επιλέξτε το  στο μενού, και μετά πατήστε . Περιμένετε μέχρι να τελειώσει το πρόγραμμα. Μια υπέροχη σούπα που αν την βάλετε στο ψυγείο από το βράδυ, την άλλη μέρα η γεύση δίνει ακόμα καλύτερα.

ΡΙΖΟΤΟ ΜΕ ΠΑΝΤΖΑΡΙ ΣΤΟΝ ΠΟΛΥΜΑΓΕΙΡΑ

250 ml	λευκό κρασί
250 g	ρύζι αρμπόριο/για ριζότο
2 🍄	σκόρδο, ξεφλουδισμένο και κομμένο
900 ml	κοτόπουλου/ λαχανικών / ζωμός κοτόπουλου

ΧΥΛΟΣ ΒΡΩΜΗΣ/ΡΙΖΟΤΟ 🍲

2 🍷	ελαιόλαδο
1	κρεμμύδι, ψιλοκομμένο
400 g	παντζάρι
1 🍷	θυμάρι, ψιλοκομμένο

ΓΙΑ ΝΑ ΟΛΟΚΛΗΡΩΣΕΤΕ:

100 ml	γιαούρτι
1 🍷	βούτυρο

1 🍷	δύσμος (ψιλοκομμένος)
-----	-----------------------

Ανοίξτε το καπάκι. Επιλέξτε το 🍷 στο μενού, και μετά πατήστε ⬇️. Προσθέστε το ζωμό. Ανακατέψτε μέχρι να βράσει. Σιγοβράστε για 10 λεπτά. Μεταφέρετε το ζωμό σε κανάτα. Πατήστε το 🍷 δύο φορές για να διακόψετε το πρόγραμμα. Επιλέξτε το 🍷 στο μενού, και μετά πατήστε ⬇️. Αφήστε το να ζεσταθεί. Ξεφλουδίστε το παντζάρι και κόψτε το σε κύβους του 1cm. Βάλτε το παντζάρι, το σκόρδο και το κρεμμύδι μέσα στο μπολ. Περιμένετε μέχρι να μαλακώσουν τα κρεμμύδια. Προσθέστε το ρύζι και ανακατέψτε. Κλείστε το καπάκι και μαγειρέψτε για 3-4 λεπτά. Ανοίξτε το καπάκι. Προσθέστε ανακατεύοντας το κρασί. Κλείστε το καπάκι και μαγειρέψτε για 3-4 λεπτά. Ανοίξτε το καπάκι. Προσθέστε το θυμάρι. Προσθέστε το ζωμό. Κλείστε το καπάκι. Περιμένετε μέχρι να τελειώσει το πρόγραμμα. Ελέγξτε το ρύζι – θα πρέπει να κρατάει λίγο αλλά να μην είναι σκληρό. Αν δεν είναι έτοιμο, προσθέστε λίγο νερό και μαγειρέψτε για λίγα λεπτά ακόμα. Προσθέστε το βούτυρο και ανακατέψτε – έτσι παίρνει τη λάμψη του το ριζότο. Σερβίρετε με ένα σβόλο γιαούρτι και πασπαλίστε με δύσμο. Το φαγητό αυτό είναι εξίσου καλό ως ορεκτικό αλλά και ως ελαφρύ γεύμα.

PORRIDGE (ΠΟΡΙΤΖ)

2 🍲	βρώμη
1¼ 🍷	αλάτι

ΧΥΛΟΣ ΒΡΩΜΗΣ/ΡΙΖΟΤΟ 🍲

	νερό
2 🍷	ζάχαρη

για να σερβίρετε:

γάλα / κρέμα γάλακτος (18-30% λιπαρά)

μαύρη ζάχαρη

Ανοίξτε το καπάκι. Προσθέστε τη βρώμη, το αλάτι και τη ζάχαρη. Γεμίστε με νερό έως το επίπεδο 1½ στην κλίμακα προς τα δεξιά, στο εσωτερικό του μπολ. Κλείστε το καπάκι. Επιλέξτε το 🍷 στο μενού, και μετά πατήστε ⬇️. Περιμένετε μέχρι να τελειώσει το πρόγραμμα. Σερβίρετε με γάλα ή κρέμα. Πασπαλίστε με σκούρα καστανή ζάχαρη. Αν θέλετε, μπορείτε να προσθέσετε κομμένα αποξηραμένα βερικόκα ή δαμάσκηνα (απύρην) κομμένα στη μέση 15 λεπτά πριν από τη λήξη του χρόνου μαγειρέματος. Το πορίτζ που θα περισσέψει διατηρείται στο ψυγείο έως και για 2 ημέρες, μετά ξαναζεσταίνεται.

PORRIDGE (ΠΟΡΙΤΖ) ΜΕ ΞΗΡΟΥΣ ΚΑΡΠΟΥΣ

½ 🍲	νιφάδες βρώμη
120 ml	γάλα
1 🍷	κανέλα σε σκόνη

ΧΥΛΟΣ ΒΡΩΜΗΣ/ΡΙΖΟΤΟ 🍲

	νερό
3 🍷	αποξηραμένη καρύδα

για να σερβίρετε:

ψιλοκομμένα καθαρισμένα αμύγδαλα

σιρόπι μελάσας golden

Ανοίξτε το καπάκι. Προσθέστε τη βρώμη, την κανέλλα, την καρύδα και γάλα. Γεμίστε με νερό έως το επίπεδο ½ στην κλίμακα προς τα δεξιά, στο εσωτερικό του μπολ. Κλείστε το καπάκι. Επιλέξτε το 🍷 στο μενού, και μετά πατήστε ⬇️. Περιμένετε μέχρι να τελειώσει το πρόγραμμα. Πασπαλίστε με σιρόπι μελάσας golden και ραντίστε με τα ψιλοκομμένα καθαρισμένα αμύγδαλα.

ΠΙΚΑΝΤΙΚΟ ΡΥΖΙ

2 🍲	ρύζι
1	κύβος ζωμού (λαχανικά)
1	κόκκινη πιπεριά, ξεποριασμένη και κομμένη
1 🍷	κουρκούμη

ΡΥΖΙ 🍲

	νερό
2	καρότα, κομμένα
2 🍷	ένα κοτσάνι σέλινο, κομμένο
1 🍷	αρακάς (προαιρετικά)

Ανοίξτε το καπάκι. Βάλτε το ρύζι μέσα στο μπολ. Γεμίστε με νερό έως το επίπεδο 2 στην κλίμακα προς τα αριστερά, στο εσωτερικό του μπολ. Τρίψτε τον κύβο ζωμού και ανακατέψτε τον μέσα στο νερό. Προσθέστε τα υπόλοιπα υλικά. Κλείστε το καπάκι. Επιλέξτε . Περιμένετε μέχρι να τελειώσει το πρόγραμμα, έπειτα σερβίρετε. Αν το ρύζι δεν είναι έτοιμο, αφήστε το για λίγα λεπτά, με το καπάκι κλειστό, να βγάλει ατμό.

ΚΟΤΟΠΟΥΛΟ ΜΕ ΝΤΟΜΑΤΕΣ ΚΑΙ ΜΑΝΙΤΑΡΙΑ

ΚΡΕΑΣ

2	φιλέτο κοτόπουλου, χωρίς πέτσα και κόκαλο	1	ελαιόλαδο
450 g	καφέ μανιτάρια, κομμένα	1	ψιλοκομμένες ντομάτες
2	σκόρδο, ξεφλουδισμένο και κομμένο	1	σάλτσα ντομάτας
1	σάλτσα Worcestershire αλάτι και πιπέρι	1	αποξηραμένη ρίγανη

Ανοίξτε το καπάκι. Επιλέξτε το στο μενού, και μετά πατήστε . Προσθέστε το λάδι. Πασπαλίστε τα κομμάτια στήθους του κοτόπουλου με αλατοπίπερο και βάλτε στο μπολ. Γυρίστε το κρέας για να σφραγίσετε και τις δύο πλευρές. Προσθέστε το σκόρδο και τα μανιτάρια. Μαγειρέψτε για 3-4 λεπτά γυρίζοντας το κοτόπουλο μια φορά. Προσθέστε τις ντομάτες, τη γούστερ σος (Worcestershire), τη σάλτσα ντομάτας και τη ρίγανη. Συνεχίστε το μαγείρεμα, γυρίζοντας το κοτόπουλο άλλη μία φορά. Ελέγξτε αν το κοτόπουλο έχει μαγειρευτεί καλά. Σερβίρετε με ζυμαρικά, πατάτες ή ρύζι. Ένα γρήγορο και νόστιμο γεύμα με υλικά που βρίσκεις στο ντουλάπι.

ΠΑΪΔΑΚΙΑ ΜΠΡΕΖΕ ΣΕ STOUT (ΕΙΔΟΣ ΜΑΥΡΗΣ ΜΠΙΡΑΣ) ΜΕ ΣΦΕΝΔΑΜΟ ΚΑΙ ΣΟΓΙΑ

ΚΡΕΑΣ

1 kg	χοιρινά παιδάκια	1	κρεμμύδι, ψιλοκομμένο
140 ml	ζωμός βοδινού / ζωμός χοιρινού	350 ml	Guinness / stout
3	σκόρδο, ξεφλουδισμένο και κομμένο	1	ελαιόλαδο
60 ml	σιρόπι σφενδάμου / μέλι		
2	σκούρα σάλτσα σόγιας		

Ανοίξτε το καπάκι. Επιλέξτε στο μενού. Προσθέστε το λάδι. Ρυθμίστε τον χρόνο μαγειρέματος σε 1 ώρα και 45 λεπτά. Πατήστε το κουμπί . Προσθέστε τα παιδάκια και τσιγαρίστε για 5 λεπτά – γυρίζοντας τα πού και πού. Αφαιρέστε τα παιδάκια. Προσθέστε το κρεμμύδι και το σκόρδο. Περιμένετε μέχρι να μαλακώσουν τα κρεμμύδια. Επιστρέψτε τα παιδάκια στο μπολ. Ρίξτε την Guinness, το ζωμό, το σιρόπι σφενδάμου και τη σάλτσα σόγιας. Κλείστε το καπάκι. Περιμένετε μέχρι να τελειώσει το πρόγραμμα. Προσθέστε μπαχαρικά κατά προτίμηση και σερβίρετε. Ένα υπέροχο ορεκτικό ή πιάτο για μπουφέ.

ΣΤΗΘΟΣ ΓΕΥΜΑ ΤΟΥΡΛΟΥ

ΑΡΓΟ ΜΑΓΕΙΡΕΜΑ

1 kg	στήθος	2	πολτός τομάτας
2	σκόρδο, ξεφλουδισμένο και κομμένο	2	φύλλο δάφνης
50 g	λουκάνικο τσορίθο, σε φέτες	2	καρότα
2	κόκκινα κρεμμύδια, ψιλοκομμένα	3	σέλινο
600 ml	ζωμός βοδινού	2	δενδρολίβανο, ψιλοκομμένο
2	ανάμεικτα αποξηραμένα βότανα	1	ψιλοκομμένες ντομάτες
6-8	πατάτες (μικρές)		αλάτι και πιπέρι
2	σάλτσα Worcestershire		

Αφήστε τις φλούδες στις πατάτες. Κόψτε τις πατάτες, τα καρότα και το σέλινο σε μεγάλα κομμάτια. Πασπαλίστε το στήθος με αλάτι και πιπέρι. Ανοίξτε το καπάκι. Επιλέξτε το στο μενού, και μετά πατήστε . Προσθέστε το ζωμό. Ανακατέψτε μέχρι να βράσει. Σιγοβράστε για 10 λεπτά. Μεταφέρετε το ζωμό σε κανάτα. Τσιγαρίστε το τσορίθο για 2 λεπτά. Προσθέστε το κρέας. Τσιγαρίστε απ' όλες τις μεριές. Προσθέστε τα κρεμμύδια, το σκόρδο, τις πατάτες, το σέλινο και τα καρότα. Αν έχετε και άλλα ριζωματώδη λαχανικά που πρέπει να χρησιμοποιηθούν, προσθέστε τα και αυτά. Περιμένετε μέχρι να μαλακώσουν τα κρεμμύδια. Προσθέστε το ζωμό. Προσθέστε τα υπόλοιπα υλικά. Πατήστε το δύο φορές για να διακόψετε το πρόγραμμα. Επιλέξτε . Περιμένετε μέχρι να τελειώσει το πρόγραμμα, έπειτα σερβίρετε. Αν το μαγειρέψετε για 8 ώρες δε θα υπάρξει πρόβλημα, αλλά μάλλον θα είναι έτοιμο για φάγωμα μετά τις 5 ώρες.

A használati utasítást olvassa el és őrizze meg; ha továbbadja a készüléket, mellékelje azt is a termékhez. Használat előtt teljes egészében távolítsa el a csomagolást.

FONTOS ÓVINTÉZKEDÉSEK

Kövesse az alábbi alapvető biztonsági óvintézkedéseket:

Az eszközt 8 éves (vagy idősebb) gyermekek és csökkent fizikai, érzékszervi vagy mentális képességekkel rendelkező vagy tapasztalatlan személyek csak felügyelet alatt/mások utasításainak megfelelően és csak akkor használhatják, ha tisztában vannak a használatból eredő kockázatokkal.

Gyermekek nem játszhatnak az eszközzel. A készülék tisztítását és karbantartását gyermekek csak felügyelet alatt és csak akkor végezhetik, ha 8 évesnél idősebbek. Tartsa az eszközt és a kábelt 8 éven aluli gyermekektől elzárva.

Ha a csatlakozó vagy a kábel sérült, le kell cserélni azokat a készülékhez tartozó speciális tartozékokra, melyeket a gyártótól vagy szervizpartnerétől szerezhet be.

 Ne használja a készüléket fürdőkád, zuhanyzó, medence vagy egyéb vizet tartalmazó edény mellett.

 A készülék helytelen használata sérülést okozhat.

 A készülék felületei felforrósodnak. A maradék hő miatt használat után forróak maradnak a felületek.

- Ne tegyen fagyott húst a készülékbe – előtte teljesen olvassza ki.
- A húst, szárnyasokat és ezek származékait (vagdaltak, húspogácsák, stb.) addig süsse, míg a szaftos állag meg nem szűnik. A halat addig süsse, míg opálos színűvé nem válik.
- Ne főzzön semmit közvetlenül a főzőedényben – főzésre csak a kivehető tálat használja.
- Ne töltse a max. jelölésnél följebb.
- Ne fedje le a készüléket és ne tegyen rá semmit.
- Húzza ki a csatlakozót a falaljzatból, majd a készülékből.
- Ha nem használja, húzza ki a készüléket.
- Ne használjon más kiegészítőket és tartozékokat, mint amit hozzá adunk.
- A készüléket az utasításokban leírtakon kívül más célra ne használja.
- Ne működtesse a készüléket, ha az megrongálódott vagy hibásan működik.

CSAK HÁZTARTÁSI HASZNÁLATRA

RAJZOK



- | | |
|-----------------|---------------|
| 1. Vezérlőpanel | 5. Mérőpohár |
| 2. Fedél | 6. Kosár |
| 3. Fedélzár | 7. Tál |
| 4. Belső fedél | 8. Csatlakozó |

ELŐKÉSZÍTÉS



1. Helyezze a készüléket egy stabil, sík, hőálló felületre.

2. A készüléket ne használja függöny mellett, polc vagy szekrény alatt, vagy olyan tárgyak közelében, amikben kárt tehet a kilépő gőz.
3. Legyen kéznél kesztyű (vagy konyharuha) és egy hőálló alátét, amire ráteheti a tálát főzés után.
4. Tegye a tálát a főzőberendezésbe.
5. Negyed fordulattal fordítsa el a tálát minden irányba, hogy a tál alja megfelelően érintkezzen a főzőelemmel.



RIZS

1. Használja a mérőpoharat, hogy a rizst a tálba tegye.
2. Ne használjon 10 pohárnyinál több rizst.
3. Használja a tál belsejében balra található skálát, amely 2-től 10-ig van jelölve
4. Töltse meg a tálát vízzel addig a jelzésig, ahány pohárnyi rizst használt.
5. Zárja le a fedelet.
6. Nyomja meg a  gombot. A gomb világítani fog.
7. A kijelző külső részei villognak, amíg az étel felmelegszik.
8. Ezután a kijelzőn megjelenik a főzés hátralevő ideje (13 perc), és a visszaszámláló.
9. A főzési idő végén a készülék átáll a „melegen tartás” módba. A  fény égni fog.
10. Nyissa ki a fedelét.
11. Vegye ki a tálát és tegye egy hőálló alátétre.
12. Nyomja meg a  gombot.
13. A kanállal keverje meg a rizst, hogy kiszabaduljon az összes gőz.
14. Időnként a rizsnek a tállal érintkező rétege kérget alkot.
15. Ha nem szeretné ezt a réteget, eltávolíthatja a spatulával a rizs feltalálása után.

LASSÚ FŐZÉS

1. Előpirított húсок és zöldségek (lásd: „PIRÍTÁS/HIRTELEN SÜTÉS/PUHÍTÁS/FORRALÁS”).
2. Forralja fel a főzőfolyadékot (lásd: „PIRÍTÁS/HIRTELEN SÜTÉS/PUHÍTÁS/FORRALÁS”).
3. Tegye a szilárd hozzávalókat a tálba, majd adja hozzá a főzőfolyadékot.
4. Zárja le a fedelet.
5. Nyomja meg a  gombot. A gomb világítani fog.
6. A kijelzőn megjelenik a 8 órás idő és a visszaszámláló.
7. A főzési idő végén a készülék átáll a „melegen tartás” módba. A  fény égni fog.
8. Nyomja meg a  gombot. Nyissa ki a fedelét. Vegye ki az ételt.

PÁROLÁS

1. Előpirított húсок és zöldségek (lásd: „PIRÍTÁS/HIRTELEN SÜTÉS/PUHÍTÁS/FORRALÁS”).
2. Forralja fel a főzőfolyadékot (lásd: „PIRÍTÁS/HIRTELEN SÜTÉS/PUHÍTÁS/FORRALÁS”).
3. Tegye a szilárd hozzávalókat a tálba, majd adja hozzá a főzőfolyadékot.
4. Zárja le a fedelet.
5. Nyomja meg a  gombot. A gomb világítani fog.
6. A kijelzőn megjelenik az 1 órás idő és a visszaszámláló.
7. A főzési idő végén a készülék átáll a „melegen tartás” módba. A  fény égni fog.
8. Nyomja meg a  gombot. Nyissa ki a fedelét. Vegye ki az ételt.

HÚS

1. Dörzsölje be a húst minden oldalról a főzőolajjal.
2. Dörzsölje be az étel felületét a kívánt fűszerekkel.
3. Tegyen egy evőkanálnyi főzőolajat a tálba.
4. Helyezze az ételt a tálba.
5. Zárja le a fedelet.
6. Az idő az étel méretétől függ.



7. Egyszerre ne főzzön 500 grammnyi ételnél nagyobb mennyiséget.
8. A marhahús javasolt főzési ideje 10 perc + 100 g húsonként 10 perc.
9. Sertést vagy szárnyast ne főzzön 5, 10, 15, 20, 25, 30 percnél rövidebb ideig.
10. Használja a ☺ gombot, hogy a menüben kiválassza a ☹ opciót.
11. Válassza ki a főzési időt. Az alapértelmezett idő 20 perc.
12. A „h” és „min” (óra és perc) gombokat csak akkor tudja használni, amikor a kijelző villog.
13. Használja a „min” gombot, hogy a kijelzőn léptesse az opciókat (10, 15, 20, 25, 5, 10, 15, 20, 25, 30, 35, 40, 45, 50 és 55).
14. Ha 1 órán keresztül szeretné főzni az ételt, nyomja meg a „h” gombot.
15. Az 1 órás beállítás visszavonásához nyomja meg ismét a „h” gombot, amikor villog a kijelző.
 - Ha 2 percig semmit nem csinál, a készülék visszaáll a készenléti módba.
16. Ha beállította az időt, nyomja meg a ◊ gombot.
17. A kijelzőn elindul a visszaszámlálás.
18. A főzési idő végén a készülék átáll a „melegen tartás” módba. A ☼ fény égni fog.
19. Nyomja meg a ☹ gombot. Nyissa ki a fedelét. Vegye ki az ételt.

LEVES

1. Előpirított húсок és zöldségek (lásd: „PIRÍTÁS/HIRTELEN SÜTÉS/PUHÍTÁS/FORRALÁS”).
2. Tegye a szilárd hozzávalókat a tálba, majd adja hozzá a főzőfolyadékot.
3. Zárja le a fedelet.
4. Használja a ☺ gombot, hogy a menüben kiválassza a ☹ opciót.
5. Válassza ki a főzési időt. Az alapértelmezett idő 1 óra.
6. A „h” és „min” (óra és perc) gombokat csak akkor tudja használni, amikor a kijelző villog.
7. Használja a „min” gombot, hogy a kijelzőn léptesse az opciókat (10, 15, 20, 25, 5, 10, 15, 20, 25, 30, 35, 40, 45, 50 és 55).
8. Használja a „h” gombot, hogy a kijelzőn léptesse az opciókat (1, 2, 3, 4 és 5).
9. Az 5 órás beállítás visszavonásához nyomja meg ismét a „h” gombot, amikor villog a kijelző.
 - Ha 2 percig semmit nem csinál, a készülék visszaáll a készenléti módba.
10. Ennél a programnál lehetősége van az időzítő használatára (lásd az IDŐZÍTŐ részt).
11. Nyomja meg a ◊ gombot.
12. A kijelzőn elindul a visszaszámlálás.
13. A főzési idő végén a készülék átáll a „melegen tartás” módba. A ☼ fény égni fog.
14. Nyomja meg a ☹ gombot. Nyissa ki a fedelét. Vegye ki az ételt.

JOGHURT

Joghurtkultúra

Használjon 5, 10, 15, 20, 25, 30 ml (2 evőkanál):

- Ízesítés nélküli élőflórás joghurtot – frisseneknek kell lennie (legyen hosszú a lejárati dátum). A különböző márkák különböző eredményt hoznak.

Korábban készített joghurtot.

- A baktériumok idővel elgyengülnek, ezért új kultúra használata előtt maximum 10-szer lehet újra használni a korábban készített joghurtot.





Fagyaszttva szárított joghurtkultúrát (gyógyszertárban vagy bioboltban kapható)

- Ha a joghurtkultúra csomagolásán található utasítások különböznek ettől az útmutatótól, a csomagolás utasításait kövesse.





Tej

- 1 liter tejre lesz szükség.
- A teljes tejből sűrűbb joghurt lesz, mint a zsírszegényből.
- Ha még sűrűbb joghurtot szeretne, adjon 8 evőkanál tejpórt a folyékony tejhez.
- Tejporból készített tejet vagy konzerv sűrített tejet is használhat.

A joghurt készítése

1. A tejben található baktériumokat meg kell semmisíteni, hogy ne kerüljenek összetűzésbe a joghurtkultúra baktériumaival.
2. Miközben a tejet melegíti, hagyja a joghurtot szobahőmérsékletűre melegedni.
3. Nyissa ki a fedelét.
4. Használja a GŐZÖLÉS (PIRÍTÁS/HIRTELEN SÜTÉS/PUHÍTÁS/FORRALÁS) programot, hogy a tejet éppen a forráspont alatti hőmérsékletre melegítse.
5. Melegítse a tejet, amíg a széleknél buborékok nem képződnek.
6. Hagyja, hogy a tej 37°C és 45°C közé hűljön.
7. Keverje a joghurtkultúrát a tejbe.
8. Alaposan keverje össze, különben a joghurt csomós lesz.
9. Zárja le a fedelet.
10. Használja a  gombot, hogy a menüben kiválassza a  opciót.
11. Válassza ki a főzési időt. Az alapértelmezett idő 8 óra.
12. A „h” és „min” (óra és perc) gombokat csak akkor tudja használni, amikor a kijelző villog.
13. Használja a „min” gombot, hogy a kijelzőn léptesse az opciókat (10, 15, 20, 25, 5, 10, 15, 20, 25, 30, 35, 40, 45, 50 és 55).
14. Használja a „h” gombot, hogy a kijelzőn léptesse az opciókat (6, 7, 8, 9 és 10).
15. Az 10 órás beállítás visszavonásához nyomja meg ismét a „h” gombot, amikor villog a kijelző.
 - Ha 2 percig semmit nem csinál, a készülék visszaáll a készenléti módba.
1. Ennél a programnál lehetősége van az időzítő használatára (lásd az IDŐZÍTŐ részt).
2. Nyomja meg a  gombot.
3. A kijelzőn elindul a visszaszámlálás.
4. A főzési idő végén a készülék készenléti üzemmódba áll.
5. Nem tartja a joghurtot melegen.
6. Nyomja meg a  gombot. Nyissa ki a fedelét. Vegye ki az ételt.





KENYÉR

1. Használat előtt alaposan olvassa le a fagyasztott tésztát.
2. Egyszerre ne főzzön 500 grammnyi ételnél nagyobb mennyiséget.
3. A főzőolajjal törölje át a tálát.
4. Tegye a tésztát a tálba.
5. Zárja le a fedelet.
6. Használja a  gombot, és válassza ki a menüben a  opciót.
7. Válassza ki a főzési időt. Az alapértelmezett idő 3 óra.
8. A „h” és „min” (óra és perc) gombokat csak akkor tudja használni, amikor a kijelző villog.
9. Használja a „min” gombot, hogy a kijelzőn léptesse az opciókat (10, 15, 20, 25, 5, 10, 15, 20, 25, 30, 35, 40, 45, 50 és 55).
10. Használja a „h” gombot, hogy a kijelzőn léptesse az opciókat (1, 2, 3, 4, 5 és 6).
11. Az 6 órás beállítás visszavonásához nyomja meg ismét a „h” gombot, amikor villog a kijelző.
 - Ha 2 percig semmit nem csinál, a készülék visszaáll a készenléti módba.
12. Ennél a programnál lehetősége van az időzítő használatára (lásd az IDŐZÍTŐ részt).
13. Nyomja meg a  gombot.
14. A kijelzőn elindul a visszaszámlálás.
15. A főzési idő végén a készülék átáll a „melegen tartás” módba. A  fény égni fog.
16. Nyomja meg a  gombot. Nyissa ki a fedelét. Vegye ki az ételt.



HAL

1. Dörzsölje be a húst minden oldalról a főzőolajjal.
2. Dörzsölje be az étel felületét a kívánt fűszerekkel.
3. Tegyen egy evőkanálnyi főzőolajat a tálba.
4. Helyezze az ételt a tálba.





5. Zárja le a fedelet.
6. Az idő az étel méretétől függ.
7. Egyszerre ne főzzön 500 grammnyi ételnél nagyobb mennyiséget.
8. A javasolt főzési idő minden 100 g súlyra 10 perc.
9. Használja a  gombot, hogy a menüben kiválassza a  opciót.
10. Válassza ki a főzési időt. Az alapértelmezett idő 20 perc.
11. A „h” és „min” (óra és perc) gombokat csak akkor tudja használni, amikor a kijelző villog.
12. Használja a „min” gombot, hogy a kijelzőn léptesse az opciókat (10, 15, 20, 25, 5, 10, 15, 20, 25, 30, 35, 40, 45, 50 és 55).
13. Ha 1 órán keresztül szeretné főzni az ételt, nyomja meg a „h” gombot.
14. Az 1 órás beállítás visszavonásához nyomja meg ismét a „h” gombot, amikor villog a kijelző.
 - Ha 2 percig semmit nem csinál, a készülék visszaáll a készenléti módba.
15. Ha beállította az időt, nyomja meg a  gombot.
16. A kijelzőn elindul a visszaszámlálás.
17. A főzési idő végén a készülék átáll a „melegen tartás” módba. A  fény égni fog.
18. Lehetőleg vegye ki az ételt, amint megfőtt, hogy ne száradjon ki.
19. Nyomja meg a  gombot. Nyissa ki a fedelét. Vegye ki az ételt.

GŐZÖLÉS

1. Töltse meg a tálat a 6-os jelzésig hideg vízzel.
2. Helyezze a kosarat a tál tetejére, és tegye az ételt a kosárba.
3. Az egyenletes párolódás érdekében vágja körülbelül egyforma darabokra az ételt.
4. Borsó, illetve olyan étel esetében, ami beleeshet a vízbe, tegyen egy darab alumínium fóliát a rácsra.
5. A fólia eltávolításakor legyen óvatos – viseljen kesztyűt és használjon műanyag csipeszt/kanalat.
6. Zárja le a fedelet.
7. Használja a  gombot, hogy a menüben kiválassza a  opciót.
8. Válassza ki a főzési időt. Az alapértelmezett idő 30 perc.
 - Az alapértelmezett idő alatt meg kell főniük az alábbiaknak:

Étel (friss)	Mennyiség
Zöldbab	200g
Kelbimbó	200g
Sárgarépa (szeletelt)	200g
Burgonya (negyedelt)	400g
Brokkoli	200g
Káposzta	Negyed
Kukoricacső	2

9. A „h” és „min” (óra és perc) gombokat csak akkor tudja használni, amikor a kijelző villog.
10. Használja a „min” gombot, hogy a kijelzőn léptesse az opciókat (5, 10, 15, 20, 25, 30, 35, 40, 45, 50 és 55).
11. Használja a „h” gombot, hogy a kijelzőn léptesse az opciókat (1 és 2).
12. Az 2 órás beállítás visszavonásához nyomja meg ismét a „h” gombot, amikor villog a kijelző.
 - Ha 2 percig semmit nem csinál, a készülék visszaáll a készenléti módba.
13. Ennél a programnál lehetősége van az időzítő használatára (lásd az IDŐZÍTŐ részt).
14. Nyomja meg a  gombot.
15. A kijelzőn elindul a visszaszámlálás.
16. A főzési idő végén a készülék átáll a „melegen tartás” módba. A  fény égni fog.
17. Lehetőleg vegye ki az ételt, amint megfőtt, hogy ne ázzon el.
18. Nyomja meg a  gombot. Nyissa ki a fedelét. Vegye ki az ételt.

PIRÍTÁS/HIRTELEN SÜTÉS/PUHÍTÁS/FORRALÁS

- A GŐZÖLÉS ☁ programot használhatja az alapértelmezett beállítással, nyitott fedéllel forró serpenyőként 5, 10, 15, 20, 25, 30 percig, mielőtt egy másik programmal elvégezné a főzést.
- Használja egy kis olajjal hús és zöldségek piritásához, hirtelen sütéshez, vagy hagyma, zeller, póréhagyma puhításához stb.
- Használja vízzel vagy az alaplével, hogy a főzőfolyadékokat előmelegítse.
- Amikor a főprogramra kapcsol, a készülék felmelegszik, és néhány (vagy az összes) hozzávaló a táliban lesz.
- Így nem kell elmosnia azt a serpenyőt, amit amúgy az előkészítéshez használt volna.

ZABKÁSA/RIZOTTÓ ☁

Használja a mérőpoharat, hogy a gabonát (rizs, zab, árpa stb.) a tálba tegye.

Zabkása

- Használja a tál belsejében jobbra található skálát, amely ½-től 1½-ig van jelölve.
- Ne töltse a **max.** jelölésnél följebb.

Congee (rizskása)

1. Használja a tál belsejében közepén található skálát, amely 1-től 3-ig van jelölve.
2. Ne töltse a **max.** jelölésnél följebb.
3. Töltse meg a tálát vízzel addig a jelzésig, ahány pohárnyi gabonát használt.
4. Zárja le a fedelet.
5. Használja a ☁ gombot, hogy a menüben kiválassza a ☁ opciót.
6. Válassza ki a főzési időt. Az alapértelmezett idő 1 óra.
7. A „h” és „min” (óra és perc) gombokat csak akkor tudja használni, amikor a kijelző villog.
8. Használja a „min” gombot, hogy a kijelzőn léptesse az opciókat (5, 10, 15, 20, 25, 30, 35, 40, 45, 50 és 55).
9. Használja a „h” gombot, hogy a kijelzőn léptesse az opciókat (1, 2, 3 és 4).
10. Az 4 órás beállítás visszavonásához nyomja meg ismét a „h” gombot, amikor villog a kijelző.
- Ha 2 percig semmit nem csinál, a készülék visszaáll a készenléti módba.
11. Ennél a programnál lehetősége van az időzítő használatára (lásd az IDŐZÍTŐ részt).
12. Nyomja meg a ⏏ gombot.
13. A kijelzőn elindul a visszaszámlálás.
14. A főzési idő végén a készülék átáll a „melegen tartás” módba. A ☁ fény égni fog.
15. Nyomja meg a ☁ gombot. Nyissa ki a fedelét. Vegye ki az ételt.

Rizottó

Kövesse a füzetben későbbiekben bemutatott receptet.



SÜTEMÉNY ☁

1. Használat előtt alaposan olvassa le a fagyasztott tésztát.
2. A tálát legfeljebb körülbelül a közepéig töltse fel.
3. A főzőolajjal törölje át a tálát.
4. Tegye a tésztát a tálba.
5. Zárja le a fedelet.
6. Használja a ☁ gombot, hogy a menüben kiválassza a ☁ opciót.
7. Válassza ki a főzési időt. Az alapértelmezett idő 40 perc.
8. Az alapértelmezett idő 40 perc.
9. A „h” és „min” (óra és perc) gombokat csak akkor tudja használni, amikor a kijelző villog.
10. Használja a „min” gombot, hogy a kijelzőn léptesse az opciókat (5, 10, 15, 20, 25, 30, 35, 40, 45, 50 és 55).
11. Használja a „h” gombot, hogy a kijelzőn léptesse az opciókat (1 és 2).
12. Az 2 órás beállítás visszavonásához nyomja meg ismét a „h” gombot, amikor villog a kijelző.
- Ha 2 percig semmit nem csinál, a készülék visszaáll a készenléti módba.
13. Ha beállította az időt, nyomja meg a ⏏ gombot.
14. A kijelzőn elindul a visszaszámlálás.
15. A főzési idő végén a készülék átáll a „melegen tartás” módba. A ☁ fény égni fog.











16. Lehetőleg vegye ki az ételt, amint megfőtt, hogy ne ázzon el.
17. Nyomja meg a  gombot. Nyissa ki a fedelét. Vegye ki az ételt.

MELEGEN TARTÁS

- Ha egy olyan program után szeretné használni a melegen tartás funkciót, ami ezt nem támogatja, akkor nyomja meg a  gombot, amikor a kijelzőn egyedül a villogó  fény jelenik meg.
- A funkcióból való kilépéshez nyomja meg a  gombot.

AZ IDŐZÍTŐ

- A leves , joghurt , kenyér , gőzölés  és zabkása  programoknál a késleltetett időzítőt is használhatja.
- Ezt a főzési idő beállítását azonnal állítsa be, mielőtt megnyomná a start  gombot:
 1. Nyomja meg a  gombot. A  fény égni fog.
 2. Döntse el, hogy mikorra szeretné elkészíteni az ételt.
 3. Ha most például délután 2 óra van, és azt szeretné, hogy az étel este 9-re készüljön el, akkor az időt 7 órára kell beállítania.
 4. A helyes óra és perc beállításához használja a **h** és **min** gombokat.
 5. Nyomja meg a  gombot.

ÁPOLÁS ÉS KARBANTARTÁS







1. Húzza ki a készüléket a konnektorból és hagyja kihűlni.
2. Húzza ki a csatlakozót a fali aljzatból, majd húzza ki a kábel másik végét a készülékből.
3. Miközben a fedél le van zárva, fogja meg a szűrő tetejét, és emelje ki a fedélből ('A' ábra).
4. Fordítsa meg, így láthatja az első peremen levő jelöléseket.
5. Tartsa erősen a szűrő fedelét, és fordítsa a szűrő többi részét a nyílt lakat  jelzés felé ('B' ábra).
6. Nyomja meg a belső fedél aljánál található peckekeket, és húzza ki a belső fedelet a készülékből. ('C' ábra).
7. Kézvel mosogassa el a levehető részeket.
8. Az összes felületet törölje le tiszta nedves kendővel.
9. Ne tegye a készülék egyetlen alkatrészét sem a mosogatógépbe.
10. Szerelje újra össze a szűrőt, és tegye vissza a fedelet.
11. Tegye vissza a belső fedelet a fedélbe.

ÚJRAHASZNOSÍTÁS



Az alábbi jelölések valamelyikével ellátott készülékekben, valamint újratölthető és nem újratölthető akkumulátorokban jelen lévő veszélyes anyagok jelentette környezeti és egészségi kockázatok elkerülése érdekében ezeket tilos háztartási hulladékkal együtt megsemmisíteni. Az elektromos és elektronikus termékeket, és, ha vannak, az újratölthető és nem újratölthető akkumulátorokat mindig a megfelelő hivatalos hulladék-újrahasznosító/begyűjtő központba kell vinni.

RECEPTEK

	evőkanál (15 ml)
	teáskanál (5 ml)
g	gramm
ml	milliliter
	mérőpohár
	szál/csík (zeller)
	maroknyi
	közepes tojás (53-63 g)

	csipetnyi
	csokor
	ágacska
	gerezd
	doboz/konzerv
	üveg
	zacskó (7g)
	nagy tojás (63-73 g)

HÁZI KÉSZÍTÉSŰ JOGHURT

JOGHURT





1200 ml tej

100 ml joghurt

ízesítési ötlet





50 g fagyasztott vegyes nyári bogyógyümölcs

1  méz





Nyissa ki a fedelét. Adja hozzá a tejet. Válassza ki a menüben a  opciót, és nyomja meg a  gombot. Melegítse a tejet, amíg a széleknél buborékok nem képződnek. A program leállításához nyomja meg kétszer a  gombot Hagyja, hogy a tej 37°C és 45°C közé hűljön. Keverje a joghurtot a tejbe. Alaposan keverje össze, különben a joghurt csomós lesz. Zárja le a fedelet. Válassza ki a menüben a  opciót, és nyomja meg a  gombot. Várjon, amíg a program lejár. Tegye a joghurtot a hűtőszekrénybe, hogy teljesen lehűljön. A gyümölcsöt óvatosan melegítse fel egy serpenyőben. Adja hozzá a mézet. Ha a gyümölcsök kezdenek összeesni, vegye le a tűzről, hagyja őket lehűlni, és keverje a joghurthoz. Ha a joghurtot el szeretné tárolni, először sterilizálnia kell a használni kívánt üvegeket. Ehhez 10 percig melegítse őket 100°C-on egy sütőben. A joghurt hűtőszekrényben körülbelül 2 hétig áll el.

TÜZES NY MARHAHÚSOS CHILI

PÁROLÁS





450 g párolt marhahús
3  fokhagyma, meghámozva és felaprítva
2  őrölt kömény
1  cayenne-bors
1  füstölt paprika/chipotle por
1 zöld paprika
1 só
1  bazsalikomlevelek, durvára aprítva

1  olívaolaj
2 hagyma, felaprítva
2  chilli por
2  paradicsomszós
2  paradicsom
1  babérlevél
1  feketebors
1  bab

Nyissa ki a fedelét. Adja hozzá az olajat. Válassza ki a menüben a  opciót, és nyomja meg a  gombot. Aprítsa fel a marhahúst, a paradicsomot és a paprikát falatnyi darabokra. Pírítsa meg a húst, majd vegye le a tűzről. Adja hozzá a hagymát, a fokhagymát és az összes fűszert. Főzze, amíg a hagymák megpuhulnak. Adja hozzá a húst. Tegye félre a babokat. Adja hozzá a többi alapanyagot. A program leállításához nyomja meg kétszer a  gombot Zárja le a fedelet. Válassza a  lehetőséget. A babokat a főzés vége előtt 30 perccel adja hozzá. Ha a hús a program végén még mindig egy kicsit rágós, adjon hozzá egy pohár vizet, és futtassa a „hús” programot további 30 percig.

ZÖLDSÉGES-KUSZKUSZOS CHILI

LASSÚ FŐZÉS

1 lilahagyma, felaprítva
1 nagy hagyma, felaprítva
2  fokhagyma, meghámozva és felaprítva
1 pirospaprika, kimagozva és felaprítva
1 sárga paprika, kimagozva és felaprítva
120-140 ml kuskusz
1  őrölt koriander
1  paradicsom püré
850 ml zöldség leves
2  csípős paradicsomszós
1 narancssárga kaliforniai paprika, kimagozva és felaprítva





1  olívaolaj
1  vajbab
1  cannellini bab
1  zöld jalapeño paprika
1  bab
1  felvágott paradicsomok
2  őrölt kömény
1  cukor
2  chilli por
2  szárított origánó

tálaláshoz:

reszelt sajt

tejföl









kis csokor koriander, felaprítva



Nyissa ki a fedelét. Adja hozzá az olajat. Válassza ki a menüben a  opciót, és nyomja meg a  gombot. Adja hozzá a hagymát és fokhagymát. Főzze, amíg a hagymák megpuhulnak. Csepegtesse le a babokat, és adja hozzá. A kuskuszt tegye félre. Adja hozzá a többi alapanyagot. A program leállításához nyomja meg kétszer a  gombot Zárja le a fedelet. Válassza a  lehetőséget. A főzés vége előtt 30 perccel adja hozzá a kuskuszt. Ha a főzés már befejeződött, válassza ki a menüben a  opciót, és főzze tovább kb. 20 percig. Egy tálba téve tálalja egy maroknyi sajttal, pár csepp tejjel és frissen őrölt korianderrel megszórva. Ha klasszikus vegetáriánus chilit szeretne készíteni, hagyja ki a kuskuszt.



MAROKKÓI HAL-TAGINE

HAL 





2 	fokhagyma, meghámozva és felaprítva	1	hagyma, felaprítva
1	pirospaprika, kimagozva és felaprítva	2 	szárzeller, felszeletelve
2	felvágott paradicsomok	1 	őrölt kömény
1 	őrölt gyömbér	1 	kurkuma
1	fahéjrúd	1 	harissa paszta
120 ml	fehérbor	1 	paradicsom püré
120 ml	hal-alaplé	1	citrom
675 g	hal (tőkehal/foltos tőkehal/lazacfilé)	1 	zöld olíva
1	kis csokor koriander, felaprítva		só és bors

Tegye félre a koriandert. Nyissa ki a fedelét. Adja hozzá a többi alapanyagot. Zárja le a fedelet. Válassza ki a menüben a  opciót, és nyomja meg a  gombot. Főzze, amíg a hal megpuhul, és a húsa kezd leválni (40-60 perc). A program leállításához nyomja meg kétszer a  gombot Adja hozzá a koriandert. Ízlés szerint fűszerezze, és tálalja. Az ételhez kuszkuszt ajánlunk.

SÁRGABORSÓS HÚSLEVES SERTÉSLÁBSZÁRBÓL







LASSÚ FŐZÉS 



1150 ml	csirkehús-leves	1	hagyma, finomra aprítva
225 g	sárgaborsó	1	sárgarépa, felaprítva
1 	szárzeller, felszeletelve	2 	fokhagyma (zúzott)
1 	kakukkfű, finomra aprítva	1 	babérlevél
1	sertéscsülök		feketebors

Nyissa ki a fedelét. Adja hozzá az alaplevet. Válassza ki a menüben a  opciót, és nyomja meg a  gombot. Forralja fel, miközben keveri. Főzze lassú tűzön 10 percig. Adja hozzá a többi alapanyagot. A program leállításához nyomja meg kétszer a  gombot Zárja le a fedelet. Válassza a  lehetőséget. Várjon, amíg a program lejár. Tegye félre a sertéscsülköt. Vágja le a bőrt, és csontozza ki a húst. Kockázza fel a húst. Dobja ki a babérlevelet. Egy fakanál hátával pürésítse a sárgaborsót. Adja hozzá a húst. Ízlés szerint fűszerezze, és tálalja. Egy tálnyi mennyiség!

LAZAC FÜSZERES KÉREGBEN

HAL 

2	lazacfilé (bőrrel együtt)	1 	olívaolaj
1 	paprika	1 	chilli por
½ 	őrölt kömény	1 	só és bors
1 	finomított barnacukor	1	citrom

Keverje össze a paprikát, a chiliport, a köményt, a cukrot, a sót és a borsot. Szórja a keveréket a lazacfilére. Nyissa ki a fedelét. Adja hozzá az olajat. Válassza ki a menüben a  opciót, és nyomja meg a  gombot. Várjon néhány percig, hogy az olaj felforrósodjon. Tegye be a lazacfilét, a bőrükkel lefelé. Zárja le a fedelet. Így a párolás és a sütés során a hal húsa puha és omlós, a bőre pedig ropogós lesz. Tálalja egy szelet citrommal. Egy nagyszerű, könnyű étel.



CSOKOLÁDÉS BROWNIE TORTA

SÜTEMÉNY 

170 g	sótlan vaj	3	 70
340 g	cukor	1 	vanília kivonat
170 g	kakaópor	1 	só
110 g	tejszokoládé-cseppek	75 g	közönséges liszt

tálaláshoz:

vanília jégkrém (opcionális)



Olvassa meg a vaját egy serpenyőben lassú tűzön. Bélelje ki a tálat alufóliával, és vajazza ki. Egy edényben keverje össze az olvasztott vaját, a cukrot, a kakaóport, a lisztet, a tojásokat, a vaníliát és a sót. Keverje bele a csokoládécseppeket. Tegye a tésztát az alufóliás tálba. Zárja le a fedelet. Válassza ki a  jelzést a menüben. Állítsa be a főzési időt 1 óra 30 percre. Nyomja meg a  gombot. Ennyi idő után a torta széle megszilárdul, de a belseje folyós marad. A tortát melegen, fagyalattal tálalva kínálja.

GŐZÖLT ARTICSKÓKA

GŐZ

1  fokhagyma, meghámozva és felaprítva
fűszernövény-ágacskák (tárkony, menta, petrezselyem, kakukkfű)



2 fej articsóka
1 citrom





Szeletelje fel a citromot. Vágja le az articsókák szárát. Vágja le az articsókák felső negyedét. Dobja ki a sérült leveleket. A vágási felületeket dörzsölje be egy szelet citrommal. Tegye a citromszeleteket a kosárba. Adja hozzá a fűszernövény-ágacskákat. Adja hozzá a fokhagymát. Tegye a tetejére az articsókát. Töltse meg az edényt vízzel a belsejében, bal oldalon található skála 2-es szintjéig. Tegye a kosarat a tál tetejére. Zárja le a fedelet. Válassza ki a menüben a  opciót, és nyomja meg a  gombot. Az articsóka akkor főtt meg, ha a külső levelei könnyen leválnak. Tálalja melegen, vagy hidegen vinaigrette-tel. Fenséges!

FEHÉR CIPÓ

KENYÉR

1  nádcukorból készült szirup
320 ml tej
500 g erős fehér kenyérliszt

1  vaj
1  szárított élesztő
1  só



Nyissa ki a fedelét. Adja hozzá a tejet. Válassza ki a menüben a  opciót, és nyomja meg a  gombot. Melegítse a tejet, amíg a széleknél buborékok nem képződnek. Öntse át a tejet egy kancsóba. A program leállításához nyomja meg kétszer a  gombot. Hagyja, hogy a tej 37°C és 45°C közé hűljön. Olvassa meg a vajat egy serpenyőben lassú tűzön. Egy edényben keverje össze a lisztet és a sót. Adja hozzá az élesztőt, a vajat és a szirupot. Öntse hozzá a tejet, és gyúrja össze egy gombóccá. Ha a keverék túl ragadós, adjon hozzá még egy kis lisztet. Takarja le, és egy meleg helyen pihentesse 10 percre. Újból gyúrja át. Takarja le, és egy meleg helyen pihentesse 10 percre. Nyissa ki a fedelét. Válassza ki a menüben a  opciót, és nyomja meg a  gombot. Zárja le a fedelet. A főzés vége előtt 30 perccel nyissa ki a fedelet. Fordítsa meg a kenyeret. Így a cipó teteje is kap egy kis színt, és ropogósabb lesz. Várjon, amíg a program lejár. Vajjal tálalja.

SZÓDÁS KENYÉR

KENYÉR



1  szódabikarbónás kenyér keverék
350 ml víz



vaj

Nyissa ki a fedelét. Vajazza ki az edényt. Válassza ki a  jelzést a menüben. Zárja le a fedelet. Állítsa a főzési időt 2 óra 15 percre. Nyomja meg a  gombot. Hagyja felmelegedni. Tegye a szódabikarbónás kenyér keveréket az edénybe. Öntse hozzá a vizet. Kézzel keverje össze egy gombóccá. Nyissa ki a fedelét. Helyezze a tésztát az edénybe. Egy műanyag spatulával válassza négyfelé a tésztát. Zárja le a fedelet. A főzés vége előtt 30 perccel nyissa ki a fedelet. Fordítsa meg a kenyeret. Így a cipó teteje is kap egy kis színt, és ropogósabb lesz. Várjon, amíg a program lejár. Hűtse ki egy rácson. Tálalja magában sózott vajjal, vagy köretként.

ÁRPAGYÖNGY ÉS BORLOTTI BAB EGYTÁLÉTEL





PÁROLÁS

1  olívaolaj
175 g árpagyöngy
1  felvágott paradicsomok
1000 ml zöldség leves
125 ml száraz vörösbőr

1  borlotti bab
1 hagyma, finomra aprítva
1  paradicsom püré
2  petrezselyem (apróra vágott)
só és bors

tálaláshoz:



csípős chiliolaj (opcionális)





Nyissa ki a fedelét. Válassza ki a menüben a  opciót, és nyomja meg a  gombot. Adja hozzá az alaplevet. Forralja fel, miközben keveri. Főzze lassú tűzön 10 percre. Öntse az alaplevet egy kancsóba. Adja hozzá az olajat. Adja hozzá a hagymát és süsse addig, míg meg nem puhul. Öntse hozzá a bort, és főzze néhány percre. Adja hozzá az árpagyöngyöt, és addig keverje, amíg elkezd átvenni a bor színét. Csepegtesse le a babot, és adja hozzá. Adja hozzá a paradicsomokat. Adja hozzá az alaplevet. A program leállításához nyomja meg kétszer a  gombot. Zárja le a fedelet. Válassza a  lehetőséget. A főzés vége előtt 30 perccel nyissa ki a fedelet. Ellenőrizze az edényben a folyadék mennyiségét. Ha szükséges, öntsön hozzá 150 ml forróvizet. Zárja le a fedelet. Várjon, amíg a program lejár. Tálalja friss, ropogós kenyérral és pár csepp csípős chiliolajjal.

IRISH STEW (IRLANDI ÜRÜGÜLYÁS) KECSKESAJTOS GALUSKÁVAL

PÁROLÁS 





a gulyáshoz:

1.8 kg	báránylapocka (főtt)
250 g	sovány szalonna
950 ml	bárány-alaplé
1	nagy hagyma, felaprítva
2 	szárzeller, felszeletelve
2 	paradicsom püré





1 	olívaolaj
3 	fokhagyma (zúzott)
	só és bors
2	sárgarépa, felaprítva
2 	rozmarying apróra vágva
1 	kukoricaliszt

a galuskához:

100 g	sütőporos liszt
50 g	birkafaggyú
75 ml	víz
40 g	lágú kecskesajt
1 	szárított majoránna

1 	sütőpor
1 	só
1 	szárított petrezselyem
1 	szárított kakukkfű
1 	feketebors

a gulyáshoz:

Válassza le a húst a csontról. Vágja a húst és a szalonnát falatnyi darabokra. Nyissa ki a fedelét. Válassza ki a menüben a  opciót, és nyomja meg a  gombot. Adja hozzá az alaplevet. Forralja fel, miközben keveri. Főzze lassú tűzön 10 percig. Öntse az alaplevet egy kancsóba. Adja hozzá az olajat. Adja hozzá a hagymát és süsse addig, míg meg nem puhul. Adja hozzá a húst, a fokhagymát, a fűszereket és a többi zöldséget, majd főzze 5 percig. Adja hozzá az alaplevet. Adja hozzá a paradicsompürét. A program leállításához nyomja meg kétszer a  gombot Zárja le a fedelet. Válassza a  lehetőséget.

a galuskához:

Kézzel keverje össze a hozzávalókat. Készítsen a keverékből 6 gombócot. Hagyja pihenni 20 percig.

az étel befejezése:



Egy csészében készítsen finom masszát a kukoricalisztből és egy kis vízből. A főzés vége előtt 30 perccel nyissa ki a fedelet. Keverje a masszát a gulyáshoz. Tegye bele a galuskákat. Zárja le a fedelet. Várjon, amíg a program lejár, majd tálalja. Egy csodálatos, klasszikus étel!



- Ha nincs főtt bárányhúsa, nyers húst is használhat, ekkor a párolás program helyett használja a lassú főzés programot, majd ugyanúgy járjon el a galuska hozzáadásától.

SZIRUPOS PISKÓTA PUDING

GŐZ 



115 g	vaj
100 g	kristálycukor
175 g	sütőporos liszt
4 	nádcukorból készült szirup



2	
¼ 	vanília kivonat
2 	tej





Verje fel a tojásokat egy tálban. Egy edényben keverje krémesre a vajat és a cukrot. Fokozatosan adja hozzá a tojásokat, majd a vaníliát, aztán a lisztet. Keverje hozzá a tejet. Vajazzon ki egy 1200 ml-es, sütőben használható edényt. Öntse a szirupot a sütőben használható edény aljára, majd öntse rá a keveréket. Takarja le sütőpapírral, majd alufóliával, és egy zsinnyel kösse össze a tetejét. Nyissa ki a fedelét. Helyezze a sütőben használható edényt a készülékben található edénybe. Öntsön elegendő forrásban levő vizet a készülékben található edénybe, hogy a vízszint a sütőben használható edény teteje alatt 3 cm-re legyen. Zárja le a fedelet. Válassza ki a  jelzést a menüben. Állítsa be a főzési időt 1 óra 30 percre. Nyomja meg a  gombot. Várjon, amíg a program lejár. Megfordítva borítsa rá egy tányérra, és melegen tálalja. Egy nagyszerű puding egész évben!

CHORIZÓS, KÁPOSZTÁS ALMÁS LEVES

LEVES



¼	chorizo kolbász, finomra vágva
1	alma
2 	szárzeller, felszeletelve
¼	káposzta, finomra vágva
2 	fokhagyma, meghámozva és felaprítva
1 	só
850 ml	zöldség leves

1	hagyma, finomra aprítva
2	sárgarépa, felaprítva
2	felvágott paradicsomok
1 	paradicsom püré
1 	cayenne-bors
1 	feketebors

Nyissa ki a fedelét. Válassza ki a menüben a  opciót, és nyomja meg a  gombot. Hirtelen süsse a chorizo kolbászt 2 percig. Adja hozzá a hagymát és fokhagymát. Főzze, amíg a hagymák megpuhulnak. Hámozza meg, magozza ki és darabolja fel az almát. Adja hozzá a többi alapanyagot. A program leállításához nyomja meg kétszer a  gombot Zárja le a fedelet. Válassza ki a menüben a  opciót, és nyomja meg a  gombot. Várjon, amíg a program lejár. Ez egy nagyszerű leves, és ha éjszakára a hűtőszekrényben hagyja, az ízek még jobban összeérnek.

PORRIDGE (ZABKÁSA)

ZABKÁSA/RIZOTTÓ



2 	zabkása
¼ 	só

	víz
2 	cukor

tálaláshoz:



barna cukor

tej / sovány tejföl

Nyissa ki a fedelét. Adja hozzá a zabpelyhet, a sót és a cukrot. Öntse fel vízzel az edényt a belsejében, jobbra található skála 1½ szintjéig. Zárja le a fedelet. Válassza ki a menüben a  opciót, és nyomja meg a  gombot. Várjon, amíg a program lejár. Tálalja tejjel vagy tejszínnel. Szórja meg barnacukorral. Ízlés szerint a főzési idő vége előtt 15 perccel adjon hozzá aprított aszalt sárgabarackot vagy félbevágott aszalt szilvát (mag nélkül). A maradék porridge akár 2 napig eltartható a hűtőben, a fogyasztáshoz melegítse fel.

MAGOS PORRIDGE

ZABKÁSA/RIZOTTÓ



½ 	zabpehely
120 ml	tej
1 	őrölt fahéj

	víz
3 	szárított kókusz

tálaláshoz:

nádcukorból készült szirup



darabolt mandula

Nyissa ki a fedelét. Keverje össze a zabot, a fahéjat, a kókuszt és a tejet. Öntse fel vízzel az edényt a belsejében, jobbra található skála ½ szintjéig. Zárja le a fedelet. Válassza ki a menüben a  opciót, és nyomja meg a  gombot. Várjon, amíg a program lejár. A tetejére csepegtessen nádcukorból készült szirupot, és szórja meg darabolt mandulával.

MULTI-COOKER CÉKLÁS RIZOTTÓ

ZABKÁSA/RIZOTTÓ

250 ml	fehérbor
1	hagyma, finomra aprítva
2 	fokhagyma, meghámozva és felaprítva
900 ml	zöldség leves / csirkehús-leves





2 	olívaolaj
250 g	arborio/rizottó rizs
400 g	cékla
1 	kakukkfű, finomra aprítva

az étel befejezése:



100 ml	joghurt
1 	vaj

1 	petrezselyem (apróra vágott)
---	------------------------------











Nyissa ki a fedelét. Válassza ki a menüben a  opciót, és nyomja meg a  gombot. Adja hozzá az alaplevet. Forralja fel, miközben keveri. Főzze lassú tűzön 10 percig. Öntse az alaplevet egy kancsóba. A program leállításához nyomja meg kétszer a  gombot Válassza ki a menüben a  opciót, és nyomja meg a  gombot. Hagyja felmelegedni. Hámozza meg a céklát, és vágja fel 1 cm-es kockákra. Tegye az edénybe a céklát, a fokhagymát és a hagymát. Főzze, amíg a hagymák megpuhulnak. Keverje hozzá a rizst. Csukja le a fedelet, és főzze 3-4 percig. Nyissa ki a fedelét. Keverje hozzá a bort. Csukja le a fedelet, és főzze 3-4 percig. Nyissa ki a fedelét. Adja hozzá a kakukkfűvet. Adja hozzá az alaplevet. Zárja le a fedelet. Várjon, amíg a program lejár. Ellenőrizze a rizst – ne legyen kemény, de még kelljen egy kicsit rágni. Ha még nincsen kész, öntsön hozzá egy kis vizet, és főzze tovább néhány percig. Keverje hozzá a vaját – ez adja meg a rizottó fényét. Tálalja egy kanálnyi joghurttal, és szórja meg petrezselyemmel. Kiváló előételnek, vagy akár egy könnyű ebédnek.

MARHASZEGYES EGYTÁLÉTEL



1 kg	marhaszegy
2 	fokhagyma, meghámozva és felaprítva
50 g	chorizo kolbász, felszeletelve
2	lilahagyma, felaprítva
600 ml	marha-alaplé
2 	száritott fűszerkeverék
6-8	burgonya (apró)
2 	Worcestershire szósz

LIASSÚ FŐZÉS



2 	paradicsom püré
2 	babérlevél
2	répa
3 	zeller
2 	rozsmaring apróra vágva
1 	felvágott paradicsomok só és bors

Hagyja a burgonyán a héjat. Vágja kis darabokra a burgonyát, a sárgarépát és a zellert. Fűszerezze a marhaszegyet sóval és borsal. Nyissa ki a fedelét. Válassza ki a menüben a  opciót, és nyomja meg a  gombot. Adja hozzá az alaplevet. Forralja fel, miközben keveri. Főzze lassú tűzön 10 percig. Öntse az alaplevet egy kancsóba. Hirtelen süsse a chorizo kolbászt 2 percig. Adja hozzá a húst. Pírítsa meg. Adja hozzá a hagymát, a fokhagymát, a burgonyát, a zellert és a sárgarépát. Ha van még gyökérgöldsége, azt is adja hozzá. Főzze, amíg a hagymák megpuhulnak. Adja hozzá az alaplevet. Adja hozzá a többi alapanyagot. A program leállításához nyomja meg kétszer a  gombot Válassza a  lehetőséget. Várjon, amíg a program lejár, majd tálalja. Nem árt az ételnek, ha 8 órán át főzi, de 5 óra után már valószínűleg fogyasztásra kész.

FÜSZERES RIZS



2 	rizs
1	leveskocka (zöldség)
1	pirospaprika, kimagozva és felaprítva
1 	kurkuma

RIZS



	víz
2	sárgarépa, felaprítva
2 	százzeller, felszeletelve
1 	borsó (opcionális)





Nyissa ki a fedelét. Tegye a rizst a tálba. Töltse meg az edényt vízzel a belsejében, bal oldalon található skála 2-es szintjéig. Törje össze a leveskockát, és keverje el vízzel. Adja hozzá a többi alapanyagot. Zárja le a fedelet. Válassza a  lehetőséget. Várjon, amíg a program lejár, majd tálalja. Ha a rizs még nem készült el, zárt fedél alatt hagyja még néhány percig gőzölni.

PARADICSOMLEVES GAZDAGON

1	hagyma, felaprítva
1 	felvágott paradicsomok
1	pirospaprika, kimagozva és felaprítva
550 ml	csirkehús-leves
1 	száritott fűszerkeverék



LEVES





1 	olívaolaj
2	felvágott paradicsomok
2	burgonyák
1 	paradicsom püré
1 	feketebors



Nyissa ki a fedelét. Adja hozzá az alaplevet. Válassza ki a menüben a  opciót, és nyomja meg a  gombot. Forralja fel, miközben keveri. Főzze lassú tűzön 10 percig. Öntse az alaplevet egy kancsóba. A program leállításához nyomja meg kétszer a  gombot Hámozza meg és kockázza fel a burgonyát. Válassza ki a menüben a  opciót, és nyomja meg a  gombot. Adja hozzá az olajat. Adja hozzá a hagymát és a kaliforniai paprikát. Főzze, amíg a hagymák megpuhulnak. Adja hozzá az alaplevet. Adja hozzá a többi alapanyagot. Zárja le a fedelet. Várjon, amíg a program lejár. Izlés szerint fűszerezze. Tálalja ropogós kenyérral.

PARADICSOMOS-GOMBÁS CSIRKE

HÚS 

- 2 csirkemellek, bőrrel és csonttal
- 450 g barna csiperkegomba, felvágva
- 2  fokhagyma, meghámozva és felaprítva
- 1  Worcestershire szósz
- só és bors



- 1  olívaolaj
- 1  felvágott paradicsomok
- 1  paradicsomszósz
- 1  szárított origánó



Nyissa ki a fedelét. Válassza ki a menüben a  opciót, és nyomja meg a  gombot. Adja hozzá az olajat. Fűszerezze a csirkemellet sóval és borssal, majd tegye az edénybe. Fordítsa meg a húst, hogy mindkét oldalát bevonja a fűszer. Adja hozzá a fokhagymát és a gombát. Főzze 3-4 percig, egyszer fordítsa meg a csirkemellet. Adja hozzá a paradicsomot, a Worcestershire szószot, a paradicsomszószot és az origánót. Folytassa a főzést, és még egyszer fordítsa meg a csirkét. Ellenőrizze, hogy a csirke megfőtt-e. Tálalja tésztával, burgonyával vagy rizzzel. Egy gyors és izletes étel egyszerű hozzávalókból.

SÖRBEŒ PÁROLT BORDA JUHARSZIRUPPAL ÉS SZÓJÁVAL

HÚS 

- 1 kg sertésborda
- 350 ml Guinness / barnasör (stout)
- 140 ml marha-alaplé / sertés-alaplé
- 3  fokhagyma, meghámozva és felaprítva

- 1 hagyma, felaprítva
- 1  olívaolaj
- 60 ml juharszirup / méz
- 2  sötét szójaszósz

Nyissa ki a fedelét. Válassza ki a  jelzést a menüben. Adja hozzá az olajat. Állítsa be a főzési időt 1 óra 45 percre. Nyomja meg a  gombot. Tegye be a bordákat, és pirítsa őket 5 percig, időnként megfordítva. Vegye ki a bordákat. Adja hozzá a hagymát és fokhagymát. Főzze, amíg a hagymák megpuhulnak. Tegye vissza a bordákat a tálba. Keverje hozzá a Guinness-t, az alaplevet, a juharszirupot és a szójaszószot. Zárja le a fedelet. Várjon, amíg a program lejár. Ízlés szerint fűszerezze, és tálalja. Kiváló előételként, vagy egy izletes ebéd részeként.



Talimatları okuyun, güvenli bir yerde saklayın, cihazın el değiştirmesi halinde cihazla birlikte aktarın. Kullanmadan önce cihazın tüm ambalajını çıkarın.

ÖNEMLİ GÜVENLİK KURALLARI

Aşağıdakiler dahil, tüm temel güvenlik önlemlerini izleyin:

Bu cihaz, 8 yaş ve üzeri çocuklar ve yetersiz fiziksel, duyuşsal veya zihinsel kapasitelere sahip veya deneyim ve bilgisi bulunmayan kişiler tarafından, sadece denetim/talimat altında olmaları ve ierilen tehlikeleri anlamaları kaydıyla kullanılabilir. Çocuklar cihazla oyun oynamamalıdır. Temizlik ve kullanıcı bakımı işlemleri, 8 yaşın üzerinde ve denetim altında olmadıkları taktirde, çocuklar tarafından gerçekleştirilmemelidir. Cihazı ve kablosunu 8 yaşın altındaki çocuklardan uzak tutun.

Konnektör veya kablo hasarlıysa, üreticiden veya yetkili servis biriminden edinilebilecek özel bir montajla yenilenmelidir.

-  Bu cihazı banyo küvetleri, duş tekneleri, lavabolar veya su ieren diğerkapların yakınında kullanmayın.
-  Cihazın yanlış biçimde kullanılması, yaralanmalara yol açabilir.
-  Cihazın yüzeyleri çok ısınabilir. Kalan ısı, yüzeyleri kullanımdan sonra sıcak tutmaya devam edecektir.
 - Cihaza dondurulmuş et veya tavuk koymayın – kullanmadan önce tamamen çözdürün.
 - Eti, kümes hayvanlarını ve türevlerini (kıyma, burger köfte, vb.) özsuları tamamen çekilene dek pişirin. Balığı etli kısmı tamamen matlaşıncaya dek pişirin.
 - Tencerenin gövdesinde herhangi bir şey pişirmeye çalışmayın – sadece çıkarılabilen kasede pişirin.
 - Max. (Maksimum) işaretinin üzerinde doldurmayın.
 - Cihazın üzerini örtmeyin veya üzerine herhangi bir şey yerleştirmeyin.
 - Fişi prizden çekin, sonra konnektörü cihazın üzerindeki güç girişinden çıkarın.
 - Kullanılmadığı zamanlarda cihazın fişini prizden çekin.
 - Size sağladığımız aksesuar ve ek parçalar dışındaki ürünleri kullanmayın.
 - Cihazı, bu talimatlarda belirtilenler dışında bir amaçla kullanmayın.
 - Hasarlı veya arızalı cihazları çalıştırmayın.

SADECE EV İİ KULLANIM

IZIMLER



- | | |
|-------------------|---------------|
| 1. Kontrol paneli | 5. Ölçüm kabı |
| 2. Kapak | 6. Sepet |
| 3. Kapak kilidi | 7. Kase |
| 4. İ kapak | 8. Konnektör |

HAZIRLAMA



1. Cihazı sabit, düz, ısıya dayanıklı bir zemin üzerine yerleştirin.
2. Cihazı perdelerin, rafların, dolapların veya çıkan buhardan zarar görebilecek herhangi bir şeyin yakınına veya altına koymayın.
3. Kaseyi tutmak için fırın eldivenleri (veya bir bez) ve pişirme sonrasında üzerine koymak için ısıya dayanıklı bir mat veya yemek tabağı kullanın.
4. Kaseyi tencerenin içine yerleştirin.

5. Kaseenin tabanının ısıtma devreleri ile tam temas etmesini sağlamak için, kaseyi her iki yönde bir çeyrek tur kadar döndürün.



PİLAV

1. Pirinci kaseye koymak için ölçüm kabını kullanın.
2. En fazla 10 fincan pirinç kullanın.
3. Sol tarafta, kaseenin içinde bulunan ve 2 ila 10 arası işaretlenmiş ölçüğü kullanın
4. Kaseyi, pirinç için kullanılan fincan sayısına karşılık gelen sayıda suyla doldurun.
5. Kapağı kapatın.
6.  düğmesine basın. Düğmenin ışığı yanacaktır.
7. Yiyecek ısınırken, ekranın dış bölmeleri yanıp sönecektir.
8. Ardından ekranda, kalan süre (13 dakika) görünecek ve geri sayım başlayacaktır.
9. Pişirme süresinin sonunda, cihaz "sıcak tutma" moduna geçecektir.  lambası yanacaktır.
10. Kapağı açın.
11. Kaseyi yukarı kaldırarak çıkarın ve ısıya dayanıklı bir mat veya yemek tabağının üzerine koyun.
12.  düğmesine basın.
13. Pilavı çevirmek ve karıştırmak ve tüm buharın çıkmasını sağlamak için spatulayı kullanın.
14. Bazen, kase ile temas eden pirinçler bir kabuk tabakası oluşturabilir.
15. Bunu tercih etmiyorsanız, pilavı servis yaptıktan sonra bu kabuk tabakasını bir spatula ile temizleyebilirsiniz.

YAVAŞ PIŞİRME





1. Et ve sebzeleri kavurun (bkz. "KAVURMA/SOTE YAPMA/YUMUŞATMA/HAŞLAMA").
2. Pişirme sıvısını kaynatın (bkz. "KAVURMA/SOTE YAPMA/YUMUŞATMA/HAŞLAMA").
3. Katı malzemeleri kaseye koyun, sonra pişirme sıvısını ekleyin.
4. Kapağı kapatın.
5.  düğmesine basın. Düğmenin ışığı yanacaktır.
6. Ekranda 8 saat görünecek ve geri sayım başlayacaktır.
7. Pişirme süresinin sonunda, cihaz "sıcak tutma" moduna geçecektir.  lambası yanacaktır.
8.  düğmesine basın. Kapağı açın. Yiyeceği çıkartın.

KENDİ SUYUNDA PIŞİRME





1. Et ve sebzeleri kavurun (bkz. "KAVURMA/SOTE YAPMA/YUMUŞATMA/HAŞLAMA").
2. Pişirme sıvısını kaynatın (bkz. "KAVURMA/SOTE YAPMA/YUMUŞATMA/HAŞLAMA").
3. Katı malzemeleri kaseye koyun, sonra pişirme sıvısını ekleyin.
4. Kapağı kapatın.
5.  düğmesine basın. Düğmenin ışığı yanacaktır.
6. Ekranda 1 saat görünecek ve geri sayım başlayacaktır.
7. Pişirme süresinin sonunda, cihaz "sıcak tutma" moduna geçecektir.  lambası yanacaktır.
8.  düğmesine basın. Kapağı açın. Yiyeceği çıkartın.

ET

1. Yiyeceğin her tarafını pişirme yağı ile ovun.
2. Yiyeceğin üzerine serpilene tüm çeşnileri ovun.
3. Kaseye bir yemek kaşığı pişirme yağı koyun.
4. Kaseye yiyeceği koymayın.
5. Kapağı kapatın.
6. süre, yiyeceğin boyutuna bağlıdır
7. Bir defada yaklaşık 500 gr'dan fazla yiyecek pişirmeyin.
8. Her 100 gr sığır eti için 10 dakika + 10 dakika pişirme süresi öneririz.
9. Domuz veya kümes hayvanlarını 5, 10, 15, 20, 25, 30 dakikadan az pişirmeyin.

10. Menüde  seçimi yapmak için  düğmesini kullanın.
11. Pişirme süresini seçin. Varsayılan süre 20 dakikadır.
12. h (saat) ve min (dakika) düğmelerini sadece ekran yanıp sönerken kullanabilirsiniz.
13. Ekranı seçenekler (10, 15, 20, 25, 5, 10, 15, 20, 25, 30, 35, 40, 45, 50 ve 55) arasında hareket ettirmek için min (dakika) düğmesini kullanın.
14. 1 saat pişirmek istiyorsanız, h (saat) düğmesine basın.
15. 1 saat ayarını geri almak için, h (saat) düğmesine, ekranda süre yanıp sönerken tekrar basın.
 - 2 dakika boyunca herhangi bir işlem yapmazsanız, cihaz Standby (Bekleme) moduna geri dönecektir.
16. Süreyi ayarladığınızda  düğmesine basın.
17. Ekranda geri sayım başlayacaktır.
18. Pişirme süresinin sonunda, cihaz "sıcak tutma" moduna geçecektir.  lambası yanacaktır.
19.  düğmesine basın. Kapağı açın. Yiyeceği çıkartın.

ÇORBA

1. Et ve sebzeleri kavurun (bkz. "KAVURMA/SOTE YAPMA/YUMUŞATMA/HAŞLAMA").
2. Katı malzemeleri kaseye koyun, sonra pişirme sıvısını ekleyin.
3. Kapağı kapatın.
4. Menüde  seçimi yapmak için  düğmesini kullanın.
5. Pişirme süresini seçin. Varsayılan süre 1 saattir.
6. h (saat) ve min (dakika) düğmelerini sadece ekran yanıp sönerken kullanabilirsiniz.
7. Ekranı seçenekler (10, 15, 20, 25, 5, 10, 15, 20, 25, 30, 35, 40, 45, 50 ve 55) arasında hareket ettirmek için min (dakika) düğmesini kullanın.
8. Ekranı seçenekler (1, 2, 3, 4 ve 5) arasında hareket ettirmek için h (dakika) düğmesini kullanın.
9. 5 saat ayarını geri almak için, h (saat) düğmesine, ekranda süre yanıp sönerken tekrar basın.
 - 2 dakika boyunca herhangi bir işlem yapmazsanız, cihaz Standby (Bekleme) moduna geri dönecektir.
10. Bu programla zamanlayıcıyı birlikte kullanma seçeneğiniz bulunmaktadır (bkz. ZAMANLAYICI).
11.  düğmesine basın.
12. Ekranda geri sayım başlayacaktır.
13. Pişirme süresinin sonunda, cihaz "sıcak tutma" moduna geçecektir.  lambası yanacaktır.
14.  düğmesine basın. Kapağı açın. Yiyeceği çıkartın.

YOĞURT

Yoğurt mayası

5, 10, 15, 20, 25, 30ml (2 yemek kaşığı).

- Tatlandırılmamış canlı yoğurt kullanabilirsiniz – taze olmalıdır (uzun kullanma süresini tercih edin). Farklı markalar farklı lezzetler verecektir.

Daha önce yaptığınız yoğurt.

- Bakteriler zamanla gücünü yitirir, bu nedenle başka, yeni bir maya kullanmadan önce bu işlemi sadece 10 kez yapabilirsiniz.

Bir eczaneden veya sağlıklı ürünler satan bir yiyecek dükkanından satın alınan dondurulmuş-kurutulmuş yoğurt mayası.





- Şayet maya ambalajının üzerindeki talimatlar, bu kılavuzda yer alan talimatlardan farklıysa, ambalaj üzerindeki talimatları izleyin.

Süt





- 1 litre süte ihtiyacınız olacaktır.
- Tam yağlı süt, az yağlı süten daha koyu yoğurt oluşturur.
- Daha da koyulaştırmak için, sıvı süte 8 yemek kaşığına kadar süt tozu ekleyebilirsiniz.
- Sulandırılarak hazırlanan süt tozu veya koyulaştırılmış süt de kullanabilirsiniz.

Yoğurt yapımı



1. Yoğurt mayasındaki bakterilerle etkileşime girmemeleri için, sütteki bakterileri öldürmelisiniz.
2. Sütü ısıtırken, yoğurt mayasının oda sıcaklığına gelmesini bekleyin.
3. Kapağı açın.

4. Sütü kaynama noktasının altında ısıtmak için BUHARDA PIŞİRME (KAVURMA/SOTE YAPMA/ YUMUŞATMA/HAŞLAMA) programını kullanın.
5. Sütü, kenarlarında kabarcıklar oluşmaya başlayana dek ısıtın.
6. Sütün 37°C - 45°C arasına gelene dek soğumasını bekleyin.
7. Yoğurt mayasını süte karıştırarak ekleyin.
8. İçice karıştırın, aksi taktirde yoğurt topak topak olacaktır.
9. Kapağı kapatın.
10. Menüde  seçimi yapmak için  düğmesini kullanın.
11. Pişirme süresini seçin. Varsayılan süre 8 saattir.
12. h (saat) ve min (dakika) düğmelerini sadece ekran yanıp sönerken kullanabilirsiniz.
13. Ekranı seçenekler (10, 15, 20, 25, 5, 10, 15, 20, 25, 30, 35, 40, 45, 50 ve 55) arasında hareket ettirmek için min (dakika) düğmesini kullanın.
14. Ekranı seçenekler (6, 7, 8, 9 ve 10) arasında hareket ettirmek için h (dakika) düğmesini kullanın.
15. 10 saat ayarını geri almak için, h (saat) düğmesine, ekranda süre yanıp sönerken tekrar basın.
- 2 dakika boyunca herhangi bir işlem yapmazsanız, cihaz Standby (Bekleme) moduna geri dönecektir.
16. Bu programla zamanlayıcıyı birlikte kullanma seçeneğiniz bulunmaktadır (bkz. ZAMANLAYICI).
17.  düğmesine basın.
18. Ekranda geri sayım başlayacaktır.
19. Pişirme süresinin sonunda, cihaz Standby (Bekleme) moduna geçecektir.
20. Yoğurdu sıcak tutmayacaktır.
21.  düğmesine basın. Kapağı açın. Yiyeceği çıkartın.

EKMEK

1. Kullanmadan önce, dondurulmuş hamuru tamamen çözdürün.
2. Bir defada yaklaşık 500 gr'dan fazla yiyecek pişirmeyin.
3. Kaseyi pişirme yağı ile sıvayın.
4. Hamuru kaseye koyun.
5. Kapağı kapatın.
6. Menüde  seçimi yapmak için  düğmesini kullanın.
7. Pişirme süresini seçin. Varsayılan süre 3 saattir.
8. h (saat) ve min (dakika) düğmelerini sadece ekran yanıp sönerken kullanabilirsiniz.
9. Ekranı seçenekler (10, 15, 20, 25, 5, 10, 15, 20, 25, 30, 35, 40, 45, 50 ve 55) arasında hareket ettirmek için min (dakika) düğmesini kullanın.
10. Ekranı seçenekler (1, 2, 3, 4, 5 ve 6) arasında hareket ettirmek için h (dakika) düğmesini kullanın.
11. 6 saat ayarını geri almak için, h (saat) düğmesine, ekranda süre yanıp sönerken tekrar basın.
- 2 dakika boyunca herhangi bir işlem yapmazsanız, cihaz Standby (Bekleme) moduna geri dönecektir.
12. Bu programla zamanlayıcıyı birlikte kullanma seçeneğiniz bulunmaktadır (bkz. ZAMANLAYICI).
13.  düğmesine basın.
14. Ekranda geri sayım başlayacaktır.
15. Pişirme süresinin sonunda, cihaz "sıcak tutma" moduna geçecektir.  lambası yanacaktır.
16.  düğmesine basın. Kapağı açın. Yiyeceği çıkartın.

BALIK

1. Yiyeceğin her tarafını pişirme yağı ile ovun.
2. Yiyeceğin üzerine serpilene tüm çeşnileri ovun.
3. Kaseye bir yemek kaşığı pişirme yağı koyun.
4. Kaseye yiyeceği koymayın.
5. Kapağı kapatın.
6. süre, yiyeceğin boyutuna bağlıdır
7. Bir defada yaklaşık 500 gr'dan fazla yiyecek pişirmeyin.
8. Her 100 gr ağırlık için 10 dakika pişirme süresi öneririz.
9. Menüde  seçimi yapmak için  düğmesini kullanın.
10. Pişirme süresini seçin. Varsayılan süre 20 dakikadır.

11. h (saat) ve min (dakika) düğmelerini sadece ekran yanıp sönerken kullanabilirsiniz.
12. Ekranı seçenekler (10, 15, 20, 25, 5, 10, 15, 20, 25, 30, 35, 40, 45, 50 ve 55) arasında hareket ettirmek için min (dakika) düğmesini kullanın.
13. 1 saat pişirmek istiyorsanız, h (saat) düğmesine basın.
14. 1 saat ayarını geri almak için, h (saat) düğmesine, ekranda süre yanıp sönerken tekrar basın.
- 2 dakika boyunca herhangi bir işlem yapmazsanız, cihaz Standby (Bekleme) moduna geri dönecektir.
15. Süreyi ayarladığınızda ◊ düğmesine basın.
16. Ekranda geri sayım başlayacaktır.
17. Pişirme süresinin sonunda, cihaz "sıcak tutma" moduna geçecektir. 🔌 lambası yanacaktır.
18. Kurummasını önlemek için yiyeceği pişer pişmez kaldırmalısınız.
19. ⏻ düğmesine basın. Kapağı açın. Yiyeceği çıkartın.

BUHARDA PIŞİRME 🍲

1. Kaseyi 6 işarete kadar soğuk suyla doldurun.
2. Sepeti kaseyin üzerine yerleştirin ve yiyecekleri sepetin içine koyun.
3. Yiyeceğin eşit oranda pişmesi için, tüm yiyecek parçalarını aşağı yukarı aynı boyutta kesin.
4. Taze fasulye, bezelye gibi kırılabilir veya suya dağılılabilecek yiyecekleri alüminyum folyoyla sararak paketleyin.
5. Paketi çıkarırken dikkatli olun – fırın eldivenleri giyin ve plastik maşa/kaşık kullanın.
6. Kapağı kapatın.
7. Menüde 🍲 seçimi yapmak için ? düğmesini kullanın.
8. Pişirme süresini seçin. Varsayılan süre 30 dakikadır.
- Aşağıdaki yiyecekler varsayılan süre içinde pişirilmelidir:

Yiyecek (taze)	Miktar
Taze fasulye	200g
Brüksel lahanası	200g
Havuç (dilimlenmiş)	200g
Yiyecek (taze)	400g
Brokoli	200g
Lahana	Dörde bölünmüş
Mısır koçanları	2

9. h (saat) ve min (dakika) düğmelerini sadece ekran yanıp sönerken kullanabilirsiniz.
10. Ekranı seçenekler (5, 10, 15, 20, 25, 30, 35, 40, 45, 50 ve 55) arasında hareket ettirmek için min (dakika) düğmesini kullanın.
11. Ekranı seçenekler (1 ve 2) arasında hareket ettirmek için h (dakika) düğmesini kullanın.
12. 2 saat ayarını geri almak için, h (saat) düğmesine, ekranda süre yanıp sönerken tekrar basın.
- 2 dakika boyunca herhangi bir işlem yapmazsanız, cihaz Standby (Bekleme) moduna geri dönecektir.
13. Bu programla zamanlayıcıyı birlikte kullanma seçeneğiniz bulunmaktadır (bkz. ZAMANLAYICI).
14. ◊ düğmesine basın.
15. Ekranda geri sayım başlayacaktır.
16. Pişirme süresinin sonunda, cihaz "sıcak tutma" moduna geçecektir. 🔌 lambası yanacaktır.
17. Fazla sulu olmasını önlemek için yiyeceği pişer pişmez kaldırmalısınız.
18. ⏻ düğmesine basın. Kapağı açın. Yiyeceği çıkartın.

KAVURMA/SOTE YAPMA/YUMUŞATMA/HAŞLAMA

- BUHARDA PIŞİRME 🍲 programını başka bir programla pişirme yapmadan önce, varsayılan ayarında, kapak açık şekilde, yüksek ısı bir tava olarak 5, 10, 15, 20, 25, 30 dakika için kullanabilirsiniz.

- Et ve sebzeleri kavurmak ve soğan, kereviz, pırasa, vb. yiyecekleri sote yapmak veya yumuşatmak için biraz yağla birlikte kullanın.
- Pişirme sıvılarını önceden ısıtmak için su veya et suyu ile birlikte kullanın.
- Ana programa geçiş yaptığınızda, cihaz ısınır ve malzemelerinizin bir kısmı veya tamamı kasede olacaktır.
- Bu nedenle, hazırlık esnasında kullandığınız tavayı yıkamanız gerekmez.





PORRIDGE (LAPA)/RISOTTO

Tahılı (pirinç, yulaf, arpa, vb.) kaseye koymak için ölçüm kabını kullanın.

Porridge (Iapa)

- Sağ tarafta, kaseenin içinde bulunan ve ½ ila 1½ arasında işaretlenmiş ölçüğü kullanın.
- **Max.** (Maksimum) işaretinin üzerinde doldurmayın.





Congee (uzakdoğu lapası)

1. Orta kısımda, kaseenin içinde bulunan ve 1 ila 3 arasında işaretlenmiş ölçüğü kullanın.
2. **Max.** (Maksimum) işaretinin üzerinde doldurmayın.
3. Kaseyi, tahıl için kullanılan fincan sayısına karşılık gelen sayıda suyla doldurun.
4. Kapağı kapatın.
5. Menüde  seçimi yapmak için  düğmesini kullanın.
6. Pişirme süresini seçin. Varsayılan süre 1 saattir.
7. h (saat) ve min (dakika) düğmelerini sadece ekran yanıp sönerken kullanabilirsiniz.
8. Ekranı seçenekler (5, 10, 15, 20, 25, 30, 35, 40, 45, 50 ve 55) arasında hareket ettirmek için min (dakika) düğmesini kullanın.
9. Ekranı seçenekler (1, 2, 3 ve 4) arasında hareket ettirmek için h (dakika) düğmesini kullanın.
10. 4 saat ayarını geri almak için, h (saat) düğmesine, ekranda süre yanıp sönerken tekrar basın.
- 2 dakika boyunca herhangi bir işlem yapmazsanız, cihaz Standby (Bekleme) moduna geri dönecektir.
11. Bu programla zamanlayıcıyı birlikte kullanma seçeneğiniz bulunmaktadır (bkz. ZAMANLAYICI).
12.  düğmesine basın.
13. Ekranda geri sayım başlayacaktır.
14. Pişirme süresinin sonunda, cihaz "sıcak tutma" moduna geçecektir.  lambası yanacaktır.
15.  düğmesine basın. Kapağı açın. Yiyeceği çıkartın.



Risotto

Bu kitapçığın ileri sayfalarında verilen tarifi uygulayın.









KEK

1. Kullanmadan önce, dondurulmuş hamuru tamamen çözündürün.
2. Kaseyi yaklaşık yarısından fazla doldurmayın.
3. Kaseyi pişirme yağı ile sıvayın.
4. Hamuru kaseye koyun.
5. Kapağı kapatın.
6. Menüde  seçimi yapmak için  düğmesini kullanın.
7. Pişirme süresini seçin. Varsayılan süre 40 dakikadır.
8. Varsayılan süre 40 dakikadır.
9. h (saat) ve min (dakika) düğmelerini sadece ekran yanıp sönerken kullanabilirsiniz.
10. Ekranı seçenekler (5, 10, 15, 20, 25, 30, 35, 40, 45, 50 ve 55) arasında hareket ettirmek için min (dakika) düğmesini kullanın.
11. Ekranı seçenekler (1 ve 2) arasında hareket ettirmek için h (dakika) düğmesini kullanın.
12. 2 saat ayarını geri almak için, h (saat) düğmesine, ekranda süre yanıp sönerken tekrar basın.
- 2 dakika boyunca herhangi bir işlem yapmazsanız, cihaz Standby (Bekleme) moduna geri dönecektir.
13. Süreyi ayarladığınızda  düğmesine basın.
14. Ekranda geri sayım başlayacaktır.
15. Pişirme süresinin sonunda, cihaz "sıcak tutma" moduna geçecektir.
16.  lambası yanacaktır.
17. Fazla sulu olmasını önlemek için yiyeceği pişer pişmez kaldırmalısınız.
18.  düğmesine basın.

SICAK TUTMA

- Sıcak tutma özelliğini onu desteklemeyen bir programdan sonra kullanmak istiyorsanız, ekrandaki tek görüntü yanıp sönen  lambası olduğunda  düğmesine basın.
- Bu özellikten çıkmak için  düğmesine basın.

ZAMANLAYICI

- Çorba , yoğurt , ekmekek , buharda pişirme  ve porridge (lapa)  programlarında zamanlayıcıyı geciktirmeyi seçebilirsiniz.
- Bunu, pişirme süresini ayarladıktan hemen sonra ve başlat  düğmesine basmadan önce yapın:
 1.  düğmesine basın.  lambası yanacaktır.
 2. Yiyeceğin ne zaman hazır olmasını istediğimize karar verin.
 3. Örneğin; şu anda saat 14.00 ise ve siz yiyeceğin saat 21.00'da hazır olmasını istiyorsanız, süreyi 7 saate ayarlamalısınız.
 4. Doğru saat ve dakika ayarını girmek için **h** (saat) ve **min** (dakika) düğmelerini kullanın.
 5.  düğmesine basın.

TEMİZLİK VE BAKIM

1. Cihazın fişini prizden çekin ve soğumaya bırakın.
2. Fişi prizden çekin, sonra konnektörü cihazın üzerindeki güç girişinden çıkarın.
3. Kapak kapalı olduğunda, filtrenin üst kısmını kavrayın ve manivela gücüyle kapaktan ayırın. (Şekil A).
4. Ön kenardaki işaretleri açığa çıkarmak için ters çevirin.
5. Filtre kapağını sabit tutun ve filtrenin kalan kısmını açık kilide  doğru çevirin (Şekil B).
6. İç kapağın tabanındaki sekmelerin üzerine bastırın ve çekerek cihazdan çıkarın (Şekil C).
7. Çıkarılabilen parçaları elde yıkayın.
8. Tüm yüzeyleri nemli bezle silin.
9. Cihazın hiçbir parçasını bulaşık makinesinde yıkamayın.
10. Filtreyi yeniden monte edin ve tekrar kapağa yerleştirin.
11. İç kapağı tekrar kapağa yerleştirin.

GERİ DÖNÜŞÜM

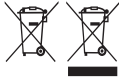

Tehlikeli maddelerin yol açacağı çevre ve sağlık sorunlarını önlemek için, şu sembollerden biri ile işaretlenmiş cihazlar ve şarj edilebilir ve tek kullanımlık piller genel evsel atıklarla birlikte çöpe atılmamalıdır. Elektrikli ve elektronik ürünleri ve ilgili olabilecek şarj edilebilir ve tek kullanımlık pilleri her zaman resmi, uygun bir geri dönüşüm/toplama noktasına bırakın.

Bakanlıkça tespit ve ilan edilen kullanım ömrü 7 yıldır

Taşıma ve nakliye sırasında dikkat edilecek hususlar :

Ürünü düşürmeyiniz

Darbelerle maruz kalmamasını sağlayınız

Cihazı nakliye sırasında orijinal ambalajında taşıyınız.

YEMEK TARIFLARI



yemek kaşığı (15ml)



çay kaşığı (5ml)

g

gram

ml

mililitre



ölçüm kabı



sap/yaprak (kereviz)



bir avuç



yumurta, orta (53-63 gr)



tutam



demet



taze otlar



sarımsak dişi (dişleri)



konserve kutusu/konserve kabı



kavanoz



paket (7 gr)





yumurta, büyük (63-73 gr)

BAHARATLA OVULMUŞ SOMON

BALIK



- 2 fileto somon (derisi üzerinde)
- 1✓ kırmızı biber
- ½✓ toz kimyon
- 1✓ yumuşak esmer şeker





- 1✓ zeytinyağı
- 1✓ acı toz kırmızıbiber
- 1✓ toz ve biber
- 1 limon

Paprika, toz chilli, kimyon, şeker, tuz ve karabiberi karıştırın. Somon filetolarının üzerine serpin. Kapağı açın. Yağı ilave edin. Menüde  seçimi yapın ve  düğmesine basın. Birkaç dakika yağın ısınmasını bekleyin. Filetoları, derileri tavaya gelecek şekilde ekleyin. Kapağı kapatın. Bu, balık parçalarını buharda pişirmekle kızartmak arasındaki muhteşem bir kombinasyondur ve çıtır çıtır bir deri elde edersiniz. Limon dilimi ile servis edin. Muhteşem bir hafif yemek.

SEBZE VE KUSKUS CHILLI





YAVAŞ PIŞİRME

- 1 kırmızı soğan, doğranmış
- 1 büyük soğan, doğranmış
- 2  sarımsak, soyulmuş ve doğranmış
- 120-140 ml kuskus
- 1 sarı biber, tohumları ayıklanmış ve doğranmış
- 1  doğranmış domates
- 2✓ toz kimyon
- 850 ml sebze suyu
- 2✓ acı toz kırmızıbiber
- 2✓ kurutulmuş kekik
- 1 kırmızı biber, tohumları ayıklanmış ve doğranmış
- 1 turuncu biber, tohumları ayıklanmış ve doğranmış

- 1✓ zeytinyağı
- 1  butter beans (fasulye)
- 1  cannellini fasulyesi
- 1  yeşil jalapeno biberi
- 1  fasulye
- 1✓ toz kişniş
- 1✓ domates püresi
- 1✓ şeker
- 2✓ sıcak somates sosu

servis için:





- rendelenmiş peynir
- küçük bir demet maydanoz, kıyılmış
- ekşi krema

Kapağı açın. Yağı ilave edin. Menüde  seçimi yapın ve  düğmesine basın. Soğan ve sarımsağı ekleyin. Soğanları yumuşayınca kadar pişirin. Fasulyeleri süzün ve onlara ekleyin. Kuskusu kenarda bekletin. Kalan malzemeleri ilave edin. Programı durdurmak için  düğmesine iki kez basın. Kapağı kapatın.  Seçimi yapın. Kuskusu pişirme süresinin sona ermesinden 30 dakika önce ekleyin. Pişirme zaten sona erdiyse, menüde  seçimi yapın ve yaklaşık 20 dakika daha pişirin. Bir kasede bir avuç dolusu peynir, biraz ekşi krema ve bir tutam taze kişnişle birlikte servis edin. Klasik bir vejeteryen chilli için, kuskusu tariften çıkarın.

EV YAPIMI YOĞURT

YOĞURT



- 1200 ml süt
- 100 ml yoğurt
- lezzet seçeneği
- 50 g dondurulmuş karışık yaz meyveleri
- 1✓ bal

Kapağı açın. Sütü ekleyin. Menüde  seçimi yapın ve  düğmesine basın. Sütü, kenarlarında kabarcıklar oluşmaya başlayana dek ısıtın. Programı durdurmak için  düğmesine iki kez basın. Sütün 37°C - 45°C arasına gelene dek soğumasını bekleyin. Yoğurdu süte karıştırarak ekleyin. İyice karıştırın, aksi takdirde yoğurt topak topak olacaktır. Kapağı kapatın. Menüde  seçimi yapın ve  düğmesine basın. Program sona erene dek bekleyin. Yoğurdu tamamen soğuması için buzdolabına koyun. Meyveleri bir tavada hafifçe ısıtın. Balı ekleyin. Meyveler canlılıklarını yitirdiğinde, tavayı ateşten alın, soğumaya bırakın ve sonra yoğurtla karıştırın. Yoğurdunuzu saklamak istiyorsanız, kullanacağınız kavanozları sterilize etmelisiniz. Onları bir fırında 100°C'de 10 dakika ısıtın. Yoğurt buzdolabında en fazla 2 hafta bekletilebilir.







ŞURUPLU SÜNGER PUDING

115 g	tereyağı
100 g	puvra Őekeri
175 g	kendiliđinden kabaran un
4	golden syrup (Őeker pekmezi)

Yumurtaları bir kasede  ırpın. Bir kasede tereyađı ve Őekeri krema haline gelinceye dek karıřtırın. Sırayla yumurtaları, vanilyayı ve unu yavař yavař ekleyin. S tle karıřtırın. 1200 ml'lik fırına dayanıklı bir kabı yađlayın. Őurubu fırına dayanıklı kabın tabanına yayın ve  zerine karıřımı d k n.  nce piřirme kađıdıyla, ardından folyo ile  zerini kapatın ve  st kısmından iple bađlayın. Kapađı a ın. Fırına dayanıklı kabı bařka bir kaba yerleřtirerek cihaza koyun. Cihaza yerleřtirdiđiniz kabın i ine, fırına dayanıklı kabın  st kısmından 3 cm ařađıda olacak Őekilde kaynar su koyun. Kapađı kapatın. Men de  se imi yapın. Piřirme s resini 1 saat 30 dakikaya ayarlayın.  d đmesine basın. Program sona erene dek bekleyin. Bir kaba ters  evirin ve sıcak servis edin. Bu, yılın her zamanı yenilebilen harika bir pudingtir!!



ACILI NY SIĐIR CHILLI

450 g	ađır ateřte piřirmeye uygun siđir eti
3	sarımsak, soyulmuř ve dođranmıř
2	toz kimyon
1	arnavut biberi
2	domates
1	defne yaprađı
1	fesleđen yaprakları, kabaca kıyılmıř
1	fasulye
1	t�ts�lenmiř paprika/chipotle (kurutulmuř biber) tozu

Kapađı a ın. Yađı ilave edin. Men de  se imi yapın ve  d đmesine basın. Siđir etini, domatesleri ve biberi kuřbařı b y kl đ nde dođrayın. Eti kavurun ve ateřten alın. Sođanları, sarımsađı ve t m otları ekleyin. Sođanları yumuřayınca kadar piřirin. Eti ilave edin. Fasulyeleri kenarda bekletin. Kalan malzemeleri ilave edin. Programı durdurmak i in  d đmesine iki kez basın. Kapađı kapatın.  Se imi yapın. Fasulyeleri, piřirme s resinin sona ermesinden 30 dakika  nce ekleyin. Et, programın sonunda h l  biraz sertse, bir fincan su ekleyin ve et programını 30 dakika daha  alıřtırın

FAS BALIK TAGINE

2	sarımsak, soyulmuř ve dođranmıř
2	kereviz sapı, dođranmıř
1	toz kimyon
1	zerde�al
120 ml	beyaz řarap
120 ml	balık suyu
675 g	balık (morina/mezgit/somon)
1	k��k bir demet maydanoz, kıyılmıř tuz ve biber
1	kırmızı biber, tohumları ayıklanmıř ve dođranmıř

Kiřniři kenarda bekletin. Kapađı a ın. Kalan malzemeleri ilave edin. Kapađı kapatın. Men de  se imi yapın ve  d đmesine basın. Balıđı gevrek olana dek piřirin (40-60 dakika). Programı durdurmak i in  d đmesine iki kez basın. Kiřniři ilave edin.  eřnilendirin ve servis edin. Kuskusla son derece iyi uyum sađlar.

PEARL BARLEY VE BORLOTTI BEAN TEK TENCERE YEMEĐI

1	borlotti bean (barbunya fasulyesi)
175 g	pearl barley (frenk arpası)
1	dođranmıř domates
1000 ml	sebze suyu
125 ml	kırmızı sek řarap

KENDI SUYUNDA PIŐIRME

BUHARDA PIŐIRME

2	
¼	vanilya esansı
2	s�t





KENDI SUYUNDA PIŐIRME

1	zeytinyađı
2	sođan, dođranmıř
2	acı toz kırmızıbiber
2	domates sosu
1	yeřil biber
1	tuz
1	karabiber

zeytinyađı

servis için:



acı biberli yağ (isteğe bağlı)





Kapağı açın. Menüde  seçimi yapın ve  düğmesine basın. Et suyunu ekleyin. Karıştırarak kaynama noktasına getirin. 10 dakika ağır ateşte yavaş yavaş kaynatın. Et suyunu bir sürahiye aktarın. Yağı ilave edin. Soğanı ekleyin ve yumuşayana dek soteleyin. Şarabı tencereye koyun ve birkaç dakika pişirin. Pearl barley'i ekleyin ve şarabın rengini almaya başlayınca dek karıştırın. Fasulyeleri süzün ve ekleyin. Domatesleri ilave edin. Et suyunu ekleyin. Programı durdurmak için  düğmesine iki kez basın. Kapağı kapatın.  Seçimi yapın. Pişirmeyi sona erdirmeden 30 dakika önce, kapağı açın. Kasedeki su miktarını kontrol edin. Gerekliyse, 150 ml sıcak su ekleyin. Kapağı kapatın. Program sona erene dek bekleyin. Taze kabuklu ekmele, üzerine acı biberli yağ gezdirerek servis edin.

KEÇİ PEYNİRİ DUMPLING'LI IRLANDA YAHNISI

KENDİ SUYUNDA PIŞİRME





yahni için:

1.8 kg	kuzu omuzu (pişirilmiş)
250 g	beykın şeritleri
950 ml	kuzu eti suyu
1	büyük soğan, doğranmış
2 	kereviz sapı, doğranmış
2 	domates püresi





1 	zeytinyağı
3 	sarımsak (ezilmiş)
	tuz ve biber
2	havuç, doğranmış
2 	biberiye, doğranmış
1 	mısır unu

dumpling'ler için:

100 g	kendiliğinden kabaran un
50 g	iç yağı
75 ml	su
40 g	keçi peyniri (yumuşak)
1 	kurutulmuş mercanköşk

1 	kabartma tozu
1 	tuz
1 	kurutulmuş maydanoz
1 	kuru kekik
1 	karabiber

yahni için:

Eti kemiklerinden ayırın. Eti ve beykını kuşbaşı doğrayın. Kapağı açın. Menüde  seçimi yapın ve  düğmesine basın. Et suyunu ekleyin. Karıştırarak kaynama noktasına getirin. 10 dakika ağır ateşte yavaş yavaş kaynatın. Et suyunu bir sürahiye aktarın. Yağı ilave edin. Soğanı ekleyin ve yumuşayana dek soteleyin. Eti, sarımsağı, otları ve diğer sebzeleri ekleyerek 5 dakika pişirin. Et suyunu ekleyin. Domates püresini ekleyin. Programı durdurmak için  düğmesine iki kez basın. Kapağı kapatın.  Seçimi yapın.

dumpling'ler için:

Tüm malzemeleri elle karıştırın. Karışımı 6 yuvarlak parçaya bölün. 20 dakika dinlendirin.



tamamlamak için:



Mısır unu ve suyu bir kapta pürüzsüz bir hamur haline getirin. Pişirmeyi sona erdirmeden 30 dakika önce, kapağı açın. Hamuru yahniye karıştırarak ekleyin. Dumpling'leri ekleyin. Kapağı kapatın. Program sona erene dek bekleyin, sonra servis yapın. Muhteşem bir kap geleneksel yemek!





Piştirilmiş hazır kutu etinin yoksa; kendi suyunda pişirme programı yerine yavaş pişirme programı ile çiğ kuzu eti de kullanılabilir, sonra dumpling aşamasından itibaren işleme devam edebilirsiniz.

SPLIT PEA VE HAM HOCK ÇORBASI

YAVAŞ PIŞİRME

1150 ml	tavuk suyu
225 g	split pea (kurutulmuş bezelye)
1 	kereviz sapı, doğranmış
1 	kekik, ince doğranmış
1	ham hock (domuz budu)

1	soğan, ince doğranmış
1	havuç, doğranmış
2 	sarımsak (ezilmiş)
1 	defne yaprağı
	karabiber

Kapağı açın. Et suyunu ekleyin. Menüde  seçimi yapın ve  düğmesine basın. Karıştırarak kaynama noktasına getirin. 10 dakika ağır ateşte yavaş yavaş kaynatın. Kalan malzemeleri ilave edin. Programı durdurmak için  düğmesine iki kez basın. Kapağı kapatın.  Seçimi yapın. Program sona erene dek bekleyin. Domuz budunu parçalayın. Derisini ve kemiklerini çıkarın. Eti zar şeklinde kesin. Defne yaprağını atın. Split pea'ları (kurutulmuş bezelye) ahşap bir kaşığın tersiyle ezin. Eti ilave edin. Çeşnilendirin ve servis edin. Bir kasede karıştırın!



ÇIKOLATALI BROWNIE KEK

KEK 

170 g	tuzsuz tereyağı	3	
340 g	şeker	1	 vanilya esansı
170 g	toz kakao	1	 tuz
110 g	sütlü çikolata damlaları	75 g	sade un

servis için:



vanilyalı dondurma (isteğe bağlı)

Tereyağını bir tavada düşük ısıda eritin. Kaseyi tereyağlı folyo ile kaplayın. Erimiş tereyağı, şeker, kakao tozu, un, yumurta, vanilya ve tuzu bir kapta çırpın. Çikolata damlalarını içine katın. Karışımı kaseyin içindeki folyoya dökün. Kapağı kapatın. Menüde  seçimi yapın. Pişirme süresini 1 saat 30 dakikaya ayarlayın.  düğmesine basın. Kekin kenar kısımları sıkı ve ortası hafifçe yapışkan olmalıdır. Keki ılık halde, üzerinde dondurma ile servis edin.

BUHARDA PIŞİRİLMİŞ ENGİNAR





BUHARDA PIŞİRME 





1	 sarımsak, soyulmuş ve doğranmış	2	yuvarlak enginar
	taze otlar (tarhun otu, nane, maydanoz, kekik)	1	limon

Limonu dilimleyin. Kökleri, her bir enginarın dibinden aynı hizada kesin. Enginarın üst çeyreğini keserek ayırın. Hasarlı tüm yaprakları atın. Kesilen yüzeyleri bir dilim limonla ovun. Limon dilimlerini bir sepete koyun. Taze otları ilave edin. Sarımsağı ekleyin. Üzerine enginarı yerleştirin. Kaseyin iç kısmında, sol taraftaki ölçekte yer alan 2 seviyesine kadar su doldurun. Sepeti kaseyin üzerine yerleştirin. Kapağı kapatın. Menüde  seçimi yapın ve  düğmesine basın. Enginarlar, dış yaprakları kolayca ayrılır hale geldiğinde pişmiştir. Vinaigrette sos ile ılık veya soğuk servis edin. Muhteşem!

BEYAZ EKMEK

EKMEK 



1	 golden syrup (şeker pekmezi)	1	 tereyağı
320 ml	süt	1	 kuru maya
500 g	ekstra beyaz ekmeğin unu	1	 tuz

Kapağı açın. Sütü ekleyin. Menüde  seçimi yapın ve  düğmesine basın. Sütü, kenarlarında kabarcıklar oluşmaya başlayana dek ısıtın. Sütü bir sürahiye aktarın. Programı durdurmak için  düğmesine iki kez basın. Sütün 37°C - 45°C arasına gelene dek soğumasını bekleyin. Tereyağını bir tavada düşük ısıda eritin. Bir kasede un ve tuzu karıştırın. Maya, tereyağı ve şurubu ilave edin. Sütü ekleyin ve yoğurarak bir hamur topu oluşturun. Karışım çok yapışkansa, biraz un ilave edin. Üzerini örtün ve ılık bir yerde 10 dakika dinlenmeye bırakın. Tekrar yoğurun. Üzerini örtün ve ılık bir yerde 10 dakika dinlenmeye bırakın. Kapağı açın. Menüde  seçimi yapın ve  düğmesine basın. Kapağı kapatın. Pişirmeyi sona erdirmeden 30 dakika önce, kapağı açın. Ekmeği ters çevirin. Bu, ekmeğin üzerinde renk ve kabuk oluşmasına yardımcı olacaktır. Program sona erene dek bekleyin. Bol tereyağı ile birlikte servis edin.

SODALI EKMEK

EKMEK 

1	 sodalı ekmeğin karışımı		tereyağı
350 ml	su		

Kapağı açın. Kaseyi tereyağı ile yağlayın. Menüde  seçimi yapın. Kapağı kapatın. Pişirme süresini 2 saat 15 dakikaya ayarlayın.  düğmesine basın. Isınmaya bırakın. Sodalı ekmeğin karışımını bir kaseye koyun. Su ilave edin. Karışımı elinizle bir top haline getirin. Kapağı açın. Hamuru kaseye koyun. Hamuru plastik bir spatula ile dört eşit parçaya bölün. Kapağı kapatın. Pişirmeyi sona erdirmeden 30 dakika önce, kapağı açın. Ekmeği ters çevirin. Bu, ekmeğin üzerinde renk ve kabuk oluşmasına yardımcı olacaktır. Program sona erene dek bekleyin. Tel bir raf üzerinde soğumaya bırakın. Sadece tuzlu tereyağı ile veya bir yemeğin yanında servis edin.

PORRIDGE (LAPA)

- 2 🍵 yulaf unu
- 1¼ 🍴 tuz

servis için:

esmer şeker

Kapağı açın. Yulaf unu, tuz ve şekeri ekleyin. Kasenin iç kısmında, sağda yer alan ölçekteki 1½ seviyesine kadar suyla doldurun. Kapağı kapatın. Menüde 🍴 seçimi yapın ve ⬇️ düğmesine basın. Program sona erene dek bekleyin. Süt veya krema ile servis edin. Üzerine esmer şeker serpin. Dilerseniz, pişirmeyi sonlandırmadan 15 dakika önce doğranmış kuru kayısı veya ikiye bölünmüş kuru erik (çekirdeksiz) ilave edebilirsiniz. Kalan porridge buzdolabında en fazla 2 gün saklanabilir, sonra tekrar ısıtılmalıdır.

CEVİZLİ PORRIDGE

- ½ 🍵 yulaf ezmesi
- 120 ml süt
- 1 🍴 toz tarçın

servis için:

golden sirup (şeker pekmezi)

Kapağı açın. Yulaf, tarçın, hindistan cevizi ve sütü ekleyin. Kasenin iç kısmında, sağda yer alan ölçekteki ½ seviyesine kadar suyla doldurun. Kapağı kapatın. Menüde 🍴 seçimi yapın ve ⬇️ düğmesine basın. Program sona erene dek bekleyin. Golden sirup (şeker pekmezi) ve onun da üzerine iri kıyılmış badem serpiştirin.

PANCARLI RISOTTO

- 400 g pancar
- 250 ml beyaz şarap
- 2 🍴 sarımsak, soyulmuş ve doğranmış
- 900 ml sebze suyu / tavuk suyu

tamamlamak için:

- 100 ml yoğurt
- 1 🍴 tereyağı

Kapağı açın. Menüde 🍴 seçimi yapın ve ⬇️ düğmesine basın. Et suyunu ekleyin. Karıştırarak kaynama noktasına getirin. 10 dakika ağır ateşte yavaş yavaş kaynatın. Et suyunu bir sürahiye aktarın. Programı durdurmak için 🍴 düğmesine iki kez basın. Menüde 🍴 seçimi yapın ve ⬇️ düğmesine basın. Isınmaya bırakın. Pancarı soyun ve 1 cm'lik küpler halinde doğrayın. Pancar, sarımsak ve soğanı bir kaseye koyun. Soğanları yumuşayınca kadar pişirin. Pirinci ekleyerek karıştırın. Kapağını kapatın ve 3-4 dakika pişirin. Kapağı açın. Şarabı ekleyin. Kapağını kapatın ve 3-4 dakika pişirin. Kapağı açın. Kekiği ilave edin. Et suyunu ekleyin. Kapağı kapatın. Program sona erene dek bekleyin. Pirinci kontrol edin – Dişe gelmeli, ancak sert olmamalıdır. Yeterince pişmediyse biraz su ekleyin ve birkaç dakika daha karıştırın. Tereyağını ekleyerek karıştırın – bu, risotto'ya parlaklığını verecektir. Biraz yoğurtla birlikte ve üzerine maydanoz serperek servis edin. Bu, gerçekten iyi bir başlangıç yemeği veya hafif bir öğle yemeğidir.

BRISKET TEK TENCERE YEMEĞİ

- 1 kg göğüs eti
- 2 🍴 sarımsak, soyulmuş ve doğranmış
- 50 g chorizo sucuğu, dilimlenmiş
- 2 kırmızı soğan, doğranmış
- 600 ml et suyu
- 2 🍴 kurutulmuş karışık otlar
- 6-8 patates (küçük)
- 2 🍴 Worcestershire sosu

PORRIDGE (LAPA)/RISOTTO 🍴

- su
- 2 🍴 şeker

süt / az yağlı

PORRIDGE (LAPA)/RISOTTO 🍴

- su
- 3 🍴 kurutulmuş hindistan cevizi

iri kıyılmış badem

PORRIDGE (LAPA)/RISOTTO 🍴





- 2 🍴 zeytinyağı
- 250 g arbori/risotto pirinci
- 1 soğan, ince doğranmış
- 1 🍴 kekik, ince doğranmış

- 1 🍴 maydanoz (doğranmış)

YAVAŞ PIŞIRME 🍴



- 2 🍴 domates püresi
- 2 🍴 defne yaprağı
- 2 havuçlenmiş
- 3 kereviz
- 2 🍴 biberiye, doğranmış
- 1 🍴 doğranmış domates tuz ve biber





Patateslerin kabuklarını üzerlerinde bırakın. Patatesleri, havuçları ve kerevizi iri parçalar halinde kesin. Göğüs etini tuz ve karabiberle çeşnilendirin. Kapağı açın. Menüde  seçimi yapın ve  düğmesine basın. Et suyunu ekleyin. Karıştırarak kaynama noktasına getirin. 10 dakika ağır ateşte yavaş yavaş kaynatın. Et suyunu bir sürahiye aktarın. Chorizo'yu 2 dakika boyunca sote edin. Eti ilave edin. Her tarafını kızartın. Soğan, sarımsak, patates, kereviz ve havuçları ilave edin. Kullanılması gereken başka herhangi bir kök sebzeniz varsa, onları da ekleyin. Soğanları yumuşayınca kadar pişirin. Et suyunu ekleyin. Kalan malzemeleri ilave edin. Programı durdurmak için  düğmesine iki kez basın.  Seçimi yapın. Program sona erene dek bekleyin, sonra servis yapın. Muhtemelen 5 saat sonra yenmeye hazır olsa da, 8 saat pişirmeniz yemeğin tadını artıracaktır.

SAVOURY RICE (ÇEŞNİLİ PILAV)

PILAV / PİRİNÇ



- 2  pirinç
- 1 et suyu tableti (sebze)
- 2  kereviz sapı, doğranmış
- 1  bezelye (isteğe bağlı)
- 1 kırmızı biber, tohumları ayıklanmış ve doğranmış



- su
- 2 havuç, doğranmış
- 1  zerdeçal





Kapağı açın. Pirinci bir kaseye koyun. Kasenin iç kısmında, sol taraftaki ölçekte yer alan 2 seviyesine kadar su doldurun. Et suyu küpünü ezin ve suyla karıştırın. Kalan malzemeleri ilave edin. Kapağı kapatın.  Seçimi yapın. Program sona erene dek bekleyin, sonra servis yapın. Pirinç henüz pişmediyse, kapağı kapalı halde birkaç dakika buharda pişmeye bırakın.

TOMATO BIG SOUP (DOMATES ÇORBASI)

ÇORBA



- 1 soğan, doğranmış
- 1  doğranmış domates
- 550 ml tavuk suyu
- 1  domates püresi
- 1  karabiber
- 1 kırmızı biber, tohumları ayıklanmış ve doğranmış



- 1  zeytinyağı
- 2 doğranmış domates
- 2 patates
- 1  kurutulmuş karışık otlar





Kapağı açın. Et suyunu ekleyin. Menüde  seçimi yapın ve  düğmesine basın. Karıştırarak kaynama noktasına getirin. 10 dakika ağır ateşte yavaş yavaş kaynatın. Et suyunu bir sürahiye aktarın. Programı durdurmak için  düğmesine iki kez basın. Patatesleri soyun ve küp şeklinde dilimleyin. Menüde  seçimi yapın ve  düğmesine basın. Yağı ilave edin. Soğanı ve tatlı biberi ilave edin. Soğanları yumuşayınca kadar pişirin. Et suyunu ekleyin. Kalan malzemeleri ilave edin. Kapağı kapatın. Program sona erene dek bekleyin. Çeşnilendirin. Kabuklu ekmele servis edin.

CHORIZO (İSPANYOL SUCUĞU), LAHANA VE ELMA ÇORBASI

ÇORBA

- ¼ chorizo sucuğu, ince doğranmış
- 1 elma
- 2  kereviz sapı, doğranmış
- ¼ lahana, ince doğranmış
- 2  sarımsak, soyulmuş ve doğranmış
- 1  tuz
- 850 ml sebze suyu

- 1 soğan, ince doğranmış
- 2 havuç, doğranmış
- 2 doğranmış domates
- 1  domates püresi
- 1  arnavut biberi
- 1  karabiber



Kapağı açın. Menüde  seçimi yapın ve  düğmesine basın. Chorizo'yu 2 dakika boyunca sote edin. Soğan ve sarımsağı ekleyin. Soğanları yumuşayınca kadar pişirin. Elmayı soyun, çekirdeğini çıkarın ve doğrayın. Kalan malzemeleri ilave edin. Programı durdurmak için  düğmesine iki kez basın. Kapağı kapatın. Menüde  seçimi yapın ve  düğmesine basın. Program sona erene dek bekleyin. Bu, buzdolabında bir gece beklettığınız takdirde lezzeti daha da artan, muhteşem bir çorbadır.

DOMATESLI VE MANTARLI TAVUK

ET 

- 2 adet tavuk göğsü, derisi ve kemikleri alınmış
- 450 g kahverengi mantar, doğranmış
- 2 sarımsak, soyulmuş ve doğranmış
- 1 Worcestershire sosu tuz ve biber

- 1 zeytinyağı
- 1 doğranmış domates
- 1 domates sosu
- 1 kurutulmuş kekik

Kapağı açın. Menüde  seçimi yapın ve  düğmesine basın. Yağı ilave edin. Tavuğun göğüs etlerini tuz ve karabiberle çeşnilendirin ve bir kaseye koyun. Eti, her iki tarafını da mühürlemek için çevirin. Sarımsağı ve mantarları ekleyin. Tavuğu sadece bir kez çevirerek 3-4 dakika pişirin. Domatesleri, Worcestershire sosunu, domates sosunu ve mercanköşkü ekleyin. Tavuğu bir kez daha çevirerek, pişirmeye devam edin. Tavuğun tamamen pişip pişmediğini kontrol edin. Makarna, patates veya pıhlavla birlikte servis edin. Malzemeleri erzak dolabında genellikle hazır olan, hızlı ve lezzetli bir yemektir.



AKÇAAĞAÇ ŞURUBU VE SOYA SOSU İLE SIYAH BIRADA AĞIR ATEŞTE PIŞİRİLEN KABURGA

ET 

(stout-braised ribs with maple and soy)

- 1 kg domuz kaburgası
- 350 ml Guinness / siyah bira
- 140 ml et suyu / domuz eti suyu
- 3 sarımsak, soyulmuş ve doğranmış

- 1 soğan, doğranmış
- 1 zeytinyağı
- 60 ml akçaağaç şurubu / bal
- 2 koyu soya sosu

Kapağı açın. Menüde  seçimi yapın. Yağı ilave edin. Pişirme süresini 1 saat 45 dakikaya ayarlayın.  düğmesine basın. Kaburgaları arada bir çevirerek 5 dakika kavurun. Kemikleri ayırın. Soğan ve sarımsağı ekleyin. Soğanları yumuşayınca kadar pişirin. Kaburgaları tekrar kaseye koyun. Guinness siyah bira, et suyu, akçaağaç şurubu ve soya sosu ile karıştırın Kapağı kapatın. Program sona erene dek bekleyin. Çeşnilendirin ve servis edin. Muhteşem bir başlangıç veya öğlen açık büfe yemeğidir.



Citiți instrucțiunile, păstrați-le într-un loc sigur; dacă dați aparatul altcuiva, nu uitați să dați și instrucțiunile. Îndepărtați toate ambalajele înainte de folosire.

PREVEDERI IMPORTANTE DE SIGURANȚĂ

Respectați măsurile de siguranță de bază, inclusiv:

Aparatul poate fi folosit de copii în vârstă de 8 ani sau mai mari și de către persoane cu capacități fizice, senzoriale sau mentale reduse sau lipsă de experiență și cunoștințe dacă sunt supravegheați/instruiți și înțeleg pericolele la care se supun. Copiii nu trebuie să se joace cu aparatul. Curățarea și utilizarea de către utilizator nu trebuie efectuate de copii decât dacă aceștia au peste 8 ani și sunt supravegheați. Nu lăsați aparatul și cablul la îndemâna copiilor sub 8 ani.

În cazul în care conectorul sau cablul este deteriorat, acestea trebuie înlocuite cu o piesă specială pe care o puteți procura de la fabricant sau de la agentul de service.

-  Nu folosiți acest aparat lângă cadă, duș, chiuvetă sau alte recipiente ce conțin apă.
-  Utilizarea incorectă a aparatului poate produce leziuni.
-  Suprafețele aparatului se vor încinge. Căldura reziduală va păstra suprafețele fierbinți după utilizare.
 - Nu puneți carnea sau puiul congelat în aparatul de gătit cu aburi – decongelați complet înainte de utilizare.
 - Gătiți carnea, puiul sau derivatele (mici, burgeri etc.) până când se evaporă sucul. Gătiți peștele până când carnea devine opacă.
 - Nu încercați să gătiți alimente în unitatea principală a aparatului de gătit - folosiți pentru aceasta doar vasul detașabil.
 - Nu depășiți limita marcată max.
 - Nu acoperiți aparatul sau nu așezați nimic pe el.
 - Scoateți întrerupătorul din priză, apoi scoateți conectorul din mufa de alimentare a aparatului.
 - Scoateți aparatul din priză atunci când nu îl folosiți.
 - Nu folosiți alte accesorii sau atașamente decât cele furnizate de noi.
 - Nu folosiți aparatul în niciun alt scop decât cel descris în aceste instrucțiuni.
 - Nu operați aparatul dacă este stricat sau nu funcționează corect.

EXCLUSIV PENTRU UZ CASNIC



SCHIȚE

- | | |
|-----------------------------|-----------|
| 1. Panoul de control | 5. Măsură |
| 2. Capac | 6. Coș |
| 3. Buton de deblocare capac | 7. Vas |
| 4. Capac interior | 8. Conect |



PREPARARE

1. Așezați aparatul pe o suprafață stabilă, nivelată, termorezistentă.
2. Nu folosiți aparatul lângă sau sub perdele, etajere, dulapuri sau orice alt obiect ce ar putea fi deteriorat de aburul care iese.
3. Țineți la îndemână mănuși de bucătărie (sau un prosop) și o rogojină termorezistentă sau o farfurie întinsă pentru a așeza vasul pe ea după preparare.
4. Introduceți vasul în aparatul de gătit.
5. Rotiți vasul un sfert de rotație în fiecare direcție, pentru a vă asigura că fundul vasului face contact corect cu elementul.



OREZ

1. Folosiți măsura pentru a introduce orez în vas.
2. Nu folosiți mai mult de 10 cești de orez.
3. Folosiți scala gradată din stânga, din interiorul vasului, care este marcată de la 2 la 10
4. Umpleți vasul cu apă până la numărul ce corespunde numărului de cești de orez folosite.
5. Închideți capacul.
6. Apăsați butonul . Dügmenin işığı yanacaktır.
7. Segmentele exterioare ale afișajului vor pâlpâi în timp ce alimentele se încălzesc.
8. Afișajul va indica apoi timpul rămas de preparare (13 minute) și numărătoarea inversă.
9. La finalul timpului de preparare, aparatul va intra în modul „păstrați mâncarea caldă”.
10. Becul  va pâlpâi.
11. Deschideți capacul.
12. Ridicați vasul și așezați-l pe o rogojină termorezistentă sau pe o farfurie întinsă.
13. Apăsați butonul .
14. Folosiți spatula pentru a întoarce și amesteca orezul, pentru a permite pătrunderea aburului.
15. Uneori, stratul de orez care intră în contact cu vasul va forma o crustă.
16. Dacă nu vă place, puteți să o îndepărtați cu spatula, după ce ați servit orezul.





GĂTIRE LENTĂ

1. Carne brună și legume (vezi „BRUNĂ/SOTÉ/FRĂGEZIRE/FIERBERE”).
2. Fierbeți lichidul de gătit (vezi „BRUNĂ/SOTÉ/FRĂGEZIRE/FIERBERE”).
3. Introduceți ingredientele solide în vas, apoi adăugați lichidul de gătit.
4. Închideți capacul.
5. Apăsați butonul . Dügmenin işığı yanacaktır.
6. Afișajul va indica 8 ore și va începe numărătoarea inversă.
7. La finalul timpului de preparare, aparatul va intra în modul „păstrați mâncarea caldă”.
8. Becul  va pâlpâi.
9. Apăsați butonul . Deschideți capacul. Scoateți alimentele.





FIERBERE ÎNĂBUȘITĂ

1. Carne brună și legume (vezi „BRUNĂ/SOTÉ/FRĂGEZIRE/FIERBERE”).
2. Fierbeți lichidul de gătit (vezi „BRUNĂ/SOTÉ/FRĂGEZIRE/FIERBERE”).
3. Introduceți ingredientele solide în vas, apoi adăugați lichidul de gătit.
4. Închideți capacul.
5. Apăsați butonul . Dügmenin işığı yanacaktır.
6. Afișajul va indica 1 oră și va începe numărătoarea inversă.
7. La finalul timpului de preparare, aparatul va intra în modul „păstrați mâncarea caldă”.
8. Becul  va pâlpâi.
9. Apăsați butonul . Deschideți capacul. Scoateți alimentele.

CARNE

1. Ungeți alimentele cu ulei de gătit.
2. Aplicați condimente pe suprafața alimentelor.
3. Puneți o lingură de ulei de ulei de gătit în vas.
4. Puneți alimentele în vas.
5. Închideți capacul.
6. Timpul de preparare depinde de cantitatea alimentelor.
7. Nu gătiți mai mult de aproximativ 500 g de alimente deodată.
8. Vă sugerăm timp de preparare de 10 minute + 10 minute per 100 g de carne de vită.
9. Nu gătiți carne de porc sau pui mai puțin de 5, 10, 15, 20, 25, 30 de minute.
10. Folosiți butonul  pentru a selecta  din meniu.
11. Selectați timpul de preparare. Perioada implicită este de 20 de minute.
12. Puteți folosi doar butoanele h și min în timp ce timpul de pe afișaj pâlpâie.
13. Folosiți butonul min pentru a naviga prin opțiunile afișajului (10, 15, 20, 25, 5, 10, 15, 20, 25, 30, 35, 40, 45, 50 și 55).
14. Dacă doriți să gătiți timp de 1 oră, apăsați butonul h.
15. Pentru a anula setarea pentru 1 oră, apăsați din nou butonul h, în timp ce ora de pe afișaj pâlpâie.
 - Dacă nu faceți nimic timp de 2 minute, aparatul va reveni la modul standby.
16. După ce ați setat timpul, apăsați .
17. Afișajul va începe numărătoarea inversă.
18. La finalul timpului de preparare, aparatul va intra în modul „păstrați mâncarea caldă”.
19. Becul  va pâlpâi.
20. Apăsați butonul . Deschideți capacul. Scoateți alimentele.

SUPĂ

1. Carne brună și legume (vezi „BRUNĂ/SOTÉ/FRĂGEZIRE/FIERBERE”).
2. Introduceți ingredientele solide în vas, apoi adăugați lichidul de gătit.
3. Închideți capacul.
4. Folosiți butonul  pentru a selecta  din meniu.
5. Selectați timpul de preparare. Timpul implicit este de 1 oră.
6. Puteți folosi doar butoanele h și min în timp ce timpul de pe afișaj pâlpâie.
7. Folosiți butonul min pentru a naviga prin opțiunile afișajului (10, 15, 20, 25, 5, 10, 15, 20, 25, 30, 35, 40, 45, 50 și 55).
8. Folosiți butonul h pentru a naviga prin opțiunile afișajului (1, 2, 3, 4 și 5).
9. Pentru a anula setarea pentru 5 oră, apăsați din nou butonul h, în timp ce ora de pe afișaj pâlpâie.
 - Dacă nu faceți nimic timp de 2 minute, aparatul va reveni la modul standby.
10. Aveți opțiunea de folosi temporizatorul cu acest program (vezi TEMPORIZATOR).
11. Apăsați butonul .
12. Afișajul va începe numărătoarea inversă.
13. La finalul timpului de preparare, aparatul va intra în modul „păstrați mâncarea caldă”.
14. Becul  va pâlpâi.
15. Apăsați butonul . Deschideți capacul. Scoateți alimentele.

IAURT

Cultura de iaurt

Puteți folosi 5, 10, 15, 20, 25, 30 ml (2 lingurițe) de:

- iaurt cu ingrediente active fără arome - trebuie să fie proaspăt (căutați unul care expiră cât mai târziu). Diferite mărci vor da diferite rezultate.

iaurtul trebuie preparat anterior.

- Bacteriile devin mai slabe în timp, puteți repeta operațiunea doar de 10 ori înainte de a folosi altă cultură.





Cultură de iaurt congelat uscat din farmacie sau magazine de alimente bio

- Dacă instrucțiunile de pe eticheta pachetului de cultură diferă de cele din acest ghid, urmați instrucțiunile de pe ambalaj.





Lapte

- Veți avea nevoie de 1 litru de lapte.
- Folosind lapte integral veți obține iaurt cu o consistență mai subțire decât cel obținut din lapte gras.
- Pentru a-l subția și mai mult, puteți adăuga până la 8 lingurițe de lapte praf la laptele lichid.
- Puteți folosi și lapte praf reconstituit sau lapte condensat.

Prepararea iaurtului

1. Trebuie să omorâți bacteriile din lapte, pentru a le lăsa să acționeze pe cele din cultura de iaurt.
2. În timp ce încălziți iaurtul, lăsați cultura de iaurt să ajungă la temperatura camerei.
3. Deschideți capacul.
4. Folosiți programul GĂTIRE CU ABURI (BRUNĂ/SOTÉ/FRĂGEZIRE/FIERBERE) pentru a încălzi laptele chiar sub pragul de fierbere.
5. Lăsați laptele să se încălzească până începe să formeze bule pe margini.
6. Lăsați laptele să se răcească la o temperatură între 37°C și 45°C
7. Amestecați cultura de iaurt în lapte.
8. Trebuie să le amestecați bine, altfel iaurtul va forma cocoloașe.
9. Închideți capacul.
10. Folosiți butonul  pentru a selecta  din meniu.
11. Selectați timpul de preparare. Timpul implicit este de 8 ore.
12. Puteți folosi doar butoanele h și min în timp ce timpul de pe afișaj pâlpâie.
13. Folosiți butonul min pentru a naviga prin opțiunile afișajului (10, 15, 20, 25, 5, 10, 15, 20, 25, 30, 35, 40, 45, 50 și 55).
14. Folosiți butonul h pentru a naviga prin opțiunile afișajului (6, 7, 8, 9 și 10).
15. Pentru a anula setarea pentru 10 oră, apăsați din nou butonul h, în timp ce ora de pe afișaj pâlpâie.
- Dacă nu faceți nimic timp de 2 minute, aparatul va reveni la modul standby.
16. Aveți opțiunea de folosi temporizatorul cu acest program (vezi TEMPORIZATOR).
17. Apăsați butonul .
18. Afișajul va începe numărătoarea inversă.
19. La finalul timpului de preparare, aparatul va intra în modul standby.
20. Va menține iaurtul cald.
21. Apăsați butonul . Deschideți capacul. Scoateți alimentele.





PÂINE

1. Decongelați aluatul congelat înainte de utilizare.
2. Nu gătiți mai mult de aproximativ 500 g de alimente deodată.
3. Ungeți vasul cu ulei de gătit.
4. Puneți aluatul în vas.
5. Închideți capacul.
6. Folosiți butonul  pentru a selecta  din meniu.
7. Selectați timpul de preparare. Timpul implicit este de 3 ore.
8. Puteți folosi doar butoanele h și min în timp ce timpul de pe afișaj pâlpâie.
9. Folosiți butonul min pentru a naviga prin opțiunile afișajului (10, 15, 20, 25, 5, 10, 15, 20, 25, 30, 35, 40, 45, 50 și 55).
10. Folosiți butonul h pentru a naviga prin opțiunile afișajului (1, 2, 3, 4, 5 și 6).
11. Pentru a anula setarea pentru 6 oră, apăsați din nou butonul h, în timp ce ora de pe afișaj pâlpâie.
- Dacă nu faceți nimic timp de 2 minute, aparatul va reveni la modul standby.
12. Aveți opțiunea de folosi temporizatorul cu acest program (vezi TEMPORIZATOR).
13. Apăsați butonul .
14. Afișajul va începe numărătoarea inversă.
15. La finalul timpului de preparare, aparatul va intra în modul „păstrați mâncarea caldă”.
16. Becul  va pâlpâi.





17. Apăsați butonul . Deschideți capacul. Scoateți alimentele.

PEȘTE



1. Ungeți alimentele cu ulei de gătit.
2. Aplicați condimente pe suprafața alimentelor.
3. Puneți o lingură de ulei de ulei de gătit în vas.
4. Puneți alimentele în vas.
5. Închideți capacul.
6. Timpul de preparare depinde de cantitatea alimentelor.
7. Nu gătiți mai mult de aproximativ 500 g de alimente deodată.
8. Vă sugerăm timp de preparare de 10 minute per 100 g de carne.
9. Folosiți butonul  pentru a selecta  din meniu.
10. Selectați timpul de preparare. Perioada implicită este de 20 de minute.
11. Puteți folosi doar butoanele h și min în timp ce timpul de pe afișaj pâlpâie.
12. Folosiți butonul min pentru a naviga prin opțiunile afișajului (10, 15, 20, 25, 5, 10, 15, 20, 25, 30, 35, 40, 45, 50 și 55).
13. Dacă doriți să gătiți timp de 1 oră, apăsați butonul h.
14. Pentru a anula setarea pentru 1 oră, apăsați din nou butonul h, în timp ce ora de pe afișaj pâlpâie.
 - Dacă nu faceți nimic timp de 2 minute, aparatul va reveni la modul standby.
15. După ce ați setat timpul, apăsați .
16. Afișajul va începe numărătoarea inversă.
17. La finalul timpului de preparare, aparatul va intra în modul „păstrați mâncarea caldă”.
18. Becul  va pâlpâi.
19. Vă recomandăm să scoateți alimentele imediat ce au fost preparate, pentru a preveni uscarea acestora.
20. Apăsați butonul . Deschideți capacul. Scoateți alimentele.

GĂTIRE CU ABURI

1. Umpleți vasul cu apă rece până la semnul 6.
2. Așezați coșul peste vas și puneți mâncarea în coș.
3. Pentru o gătire uniformă, tăiați alimentele în bucăți cam de aceeași mărime.
4. Pentru mazăre, sau orice aliment care se desface sau cade în apă, înfășurați coșul cu folie din aluminiu
5. Fiți atenți când îndepărtați folia – folosiți mănuși de bucătărie și clești/linguri de plastic.
6. Închideți capacul.
7. Folosiți butonul  pentru a selecta  din meniu.
8. Selectați timpul de preparare. Perioada implicită este de 30 de minute.
 - Aceasta trebuie gătită în intervalul de preparare implicit:

Alimente (proaspete)	Cantitate
Fasole verde	200g
Varză de bruxelles	200g
Morcovi (felii)	200g
Cartofi (tăiați în patru)	400g
Broccoli	200g
Varză	Sferturi
Coceni de porumb	2

9. Puteți folosi doar butoanele h și min în timp ce timpul de pe afișaj pâlpâie.
10. Folosiți butonul min pentru a naviga prin opțiunile afișajului (5, 10, 15, 20, 25, 30, 35, 40, 45, 50 și 55).
11. Folosiți butonul h pentru a naviga prin opțiunile afișajului (1 și 2).

12. Pentru a anula setarea pentru 2 oră, apăsați din nou butonul h, în timp ce ora de pe afișaj pâlpâie.
 - Dacă nu faceți nimic timp de 2 minute, aparatul va reveni la modul standby.
13. Aveți opțiunea de folosi temporizatorul cu acest program (vezi TEMPORIZATOR).
14. Apăsați butonul .
15. Afișajul va începe numărătoarea inversă.
16. La finalul timpului de preparare, aparatul va intra în modul „păstrați mâncarea caldă”.
17. Becul  va pâlpâi.
18. Vă recomandăm să scoateți alimentele imediat ce au fost preparate, pentru a preveni afumarea acestora.
19. Apăsați butonul . Deschideți capacul. Scoateți alimentele.

BRUNĂ/SOTÉ/FRĂGEZIRE/FIERBERE

- Puteți folosi programul GĂTIRE CU ABURI  la setarea implicită, cu capacul deschis, drept cratiță, la temperatură ridicată, timp de 5, 10, 15, 20, 25, 30 de minute, înainte de a folosi alt program.
- Folosiți-l cu puțin ulei, pentru a rumeni carnea și legumele, sotéul, pentru a înmuia ceapa, țelina, prazul etc.
- Folosiți-l cu apă sau supă pentru a preîncălzi lichidele de gătit.
- Când comutați pe programul principal, aparatul s-a încălzit, iar unele ingrediente, ori toate, vor fi deja în vas.
- Nu trebuie să spălați cratița pe care ați folosit-o pentru gătit.





PORRIDGE (TERCI DE OVĂZ) /RIZOTO

Folosiți măsura pentru a pune boabele (orez, ovăz, orz etc.) în vas.

Porridge (terci de ovăz)

- Folosiți scala gradată din dreapta, din interiorul vasului, care este marcată de la 1/2 la 1 1/2.
- Nu depășiți limita marcată **max**.

Congee

- Folosiți scala gradată din centru, din interiorul vasului, care este marcată de la 1 la 3.
 - Nu depășiți limita marcată **max**.
1. Umpleți vasul cu apă până la numărul ce corespunde numărului de cești de boabe.
 2. Închideți capacul.
 3. Folosiți butonul  pentru a selecta  din meniu.
 4. Selectați timpul de preparare. Timpul implicit este de 1 oră.
 5. Puteți folosi doar butoanele h și min în timp ce timpul de pe afișaj pâlpâie.
 6. Folosiți butonul min pentru a naviga prin opțiunile afișajului (5, 10, 15, 20, 25, 30, 35, 40, 45, 50 și 55).
 7. Folosiți butonul h pentru a naviga prin opțiunile afișajului (1, 2, 3 și 4).
 8. Pentru a anula setarea pentru 4 oră, apăsați din nou butonul h, în timp ce ora de pe afișaj pâlpâie.
 - Dacă nu faceți nimic timp de 2 minute, aparatul va reveni la modul standby.
 9. Aveți opțiunea de folosi temporizatorul cu acest program (vezi TEMPORIZATOR).
 10. Apăsați butonul .
 11. Afișajul va începe numărătoarea inversă.
 12. La finalul timpului de preparare, aparatul va intra în modul „păstrați mâncarea caldă”.
 13. Becul  va pâlpâi.
 14. Apăsați butonul . Deschideți capacul. Scoateți alimentele.





Rizoto

Urmați rețeta prezentată mai jos în broșură.



PRĂJITURĂ

1. Decongeleți aluatul congelat înainte de utilizare.
2. Nu umpleți vasul mai mult de jumătate.
3. Ungeți vasul cu ulei de gătit.
4. Puneți aluatul în vas.











5. Închideți capacul.
6. Folosiți butonul  pentru a selecta  din meniu.
7. Selectați timpul de preparare. Perioada implicită este de 40 de minute.
8. Perioada implicită este de 40 de minute.
9. Puteți folosi doar butoanele h și min în timp ce timpul de pe afișaj pâlpâie.
10. Folosiți butonul min pentru a naviga prin opțiunile afișajului (5, 10, 15, 20, 25, 30, 35, 40, 45, 50 și 55).
11. Folosiți butonul h pentru a naviga prin opțiunile afișajului (1 și 2).
12. Pentru a anula setarea pentru 2 oră, apăsați din nou butonul h, în timp ce ora de pe afișaj pâlpâie.
 - Dacă nu faceți nimic timp de 2 minute, aparatul va reveni la modul standby.
13. După ce ați setat timpul, apăsați .
14. Afișajul va începe numărătoarea inversă.
15. La finalul timpului de preparare, aparatul va intra în modul „păstrați mâncarea caldă”.
16. Becul  va pâlpâi.
17. Vă recomandăm să scoateți alimentele imediat ce au fost preparate, pentru a preveni afumarea acestora.
18. Apăsați butonul . Deschideți capacul. Scoateți alimentele.

PĂSTRAȚI MÂNCAREA CALDĂ

- Dacă doriți să folosiți funcția păstrați mâncarea caldă după un program care nu o are, atunci când singurul lucru pe afișaj este becul , apăsați .
- Apăsați  pentru a ieși din această funcție.

TEMPORIZATORUL

- Puteți folosi temporizatorul cu întârziere pentru programele supă , iaurt , pâine , abur  și porridge .
- Faceți acest lucru imediat după ce ați setat timpul de preparare și înainte de a apăsa start :
 1. Apăsați butonul . Becul  va pâlpâi.
 2. Decideți când doriți să fie gata mâncarea.
 3. Spre exemplu., dacă acum este ora 2:00 și doriți ca mâncarea să fie gata la ora 9:00, trebuie să setați timpul la 7 ore.
 4. Folosiți butoanele h și min pentru a seta ora și minutele corecte.
 5. Apăsați butonul .

ÎNGRIJIRE ȘI ÎNTREȚINERE









1. Scoateți aparatul din priză și lăsați-l să se răcească.
2. Scoateți întrerupătorul din priză, apoi scoateți conectorul din mufa de alimentare a aparatului.
3. Cu capacul închis, prindeți partea de sus a filtrului și scoateți-l de pe capac. (FIG.A)
4. Întoarceți-l, pentru a expune semnele de pe marginea frontală.
5. Țineți capacul filtrului bine și rotiți restul filtrului înspre lacătul deschis  (FIG.B)
6. Apăsați pe capetele din partea de jos a capacului interior și trageți-l de pe aparat (FIG.C)
7. Țikarilabilen parçaları elde yıkayın.
8. Ștergeți suprafețele exterioare cu o cârpă umedă curată.
9. Nu spălați nicio componentă a aparatului la mașina de spălat vase.
10. Reasamblați filtrul și remontați-l în capac.
11. Puneți la loc capacul interior în capac.





RECICLAREA



Pentru a evita problemele de mediu și de sănătate cauzate de substanțele periculoase, aparatele și bateriile reîncărcabile și cele obișnuite marcate cu unul dintre aceste simboluri, nu trebuie eliminate împreună cu deșeurile municipale nesortate. Eliminați întotdeauna produsele electrice și electronice și, după caz, bateriile reîncărcabile și cele obișnuite, la un punct de reciclare/colectare corespunzător.

REȚETE

-  o lingură (15ml)
-  o linguriță (5ml)
-  grame
-  mililitri
-  măsură
-  bucată/legătură (țelină)
-  un pumn
-  ou, mediu (53-63 g)

-  un praf de
-  o legătură
-  crenguță
-  cățel/căței
-  conservă/cutie
-  borcan
-  pachet (7 g)
-  ou, mare (63-73 g)

IAURT DE CASĂ





1200 ml lapte

100 ml iaurt

opțiuni de arome







50 g mixt de fructe de pădure congelate

1  miere







Deschideți capacul. Adăugați laptele. Selectați  din meniu și apăsați . Lăsați laptele să se încălzească până începe să formeze bule pe margini. Apăsați  de două ori, pentru a opri programul. Lăsați laptele să se răcească la o temperatură între 37°C și 45°C Amestecați iaurtul în lapte. Trebuie să le amestecați bine, altfel iaurtul va forma cocoloașe. Închideți capacul. Selectați  din meniu și apăsați . Așteptați până când programul se termină. Puneți iaurtul la frigider, pentru a se răci complet. Încălziți ușor fructele de pădure într-o cratiță. Adăugați mierea. Când fructele de pădure încep să se desfacă, luați-le de pe foc, lăsați-le să se răcească, apoi adăugați iaurtul și amestecați. Dacă doriți să depozitați iaurtul, trebuie să sterilizați borcanele pe care le veți folosi. Încălziți-le în cuptor, la 100°C, timp de 10 minute. Iaurtul se va păstra până la 2 săptămâni la frigider.





IAURT

CHILLI FOARTE IUTE DE VITĂ, A LA NY



- 450 g carne de vită înăbușită
- 3  usturoi, curățat și tocat
- 2  chimen măcinat
- 1  piper cayenne
- 1  paprica afumat/chipotle pudră
- 1 ardei verde
- 1  sare
- 1  frunze de busuioc, tocate mare

FIERBERE ÎNĂBUȘITĂ



- 1  ulei de măsline
- 2 ceapă, tocată
- 2  pudră de chilli
- 2  suc de roșii
- 2  roșii
- 1  foi de dafin
- 1  piper negru
- 1  fasole



Deschideți capacul. Adăugați uleiul. Selectați  din meniu și apăsați . Tăiați carnea de vită, roșiile și ardeiul în bucățele mici. Rumeniți carnea, apoi luați-o de pe foc. Adăugați ceapa, usturoiul și toate ierburile. Gătiți până când ceapa se înmoaie. Adăugați carnea. Lăsați fasolea deoparte. Adăugați celelalte ingrediente. Apăsați  de două ori, pentru a opri programul. Închideți capacul. Selectați . Adăugați fasolea cu 30 de minute înainte de terminarea timpului de preparare. În cazul în care carnea este puțin tare la finalul programului, adăugați o cană de apă și porniți programul pentru carne încă 30 de minute.

SOMON CU CONDIMENTE IUȚI

- 2 fileuri de somon (cu piele)
- 1  ardei roșu
- ½  chimen măcinat
- 1  zahăr brun slab

PEȘTE



- 1  ulei de măsline
- 1  pudră de chilli
- 1  sare și piper
- 1 lămâie

Amestecați paprica, pudra de chilli, chimenul, zahărul, sarea și piperul. Presărați peste fileurile de somon. Deschideți capacul. Adăugați uleiul. Selectați  din meniu și apăsați . Așteptați câteva minute pentru a lăsa uleiul să se încălzească. Adăugați fileurile, cu pielea în jos. Închideți capacul. Aceasta este o combinație perfectă bucăți de pește preparat la aburi și prăjit, pielea devenind crocantă. Serviți cu o bucată de lămâie. O masă ușoară delicioasă.

ANGHINARE LA ABURI















ABUR 

1 	usturoi, curătat și tocat	2	anghinare
	crenguțe de ierburi (tarhon, mentă, pătrunjel, cimbru)	1	lămâie

Feliați lămâia. Taiăți coada din partea de jos a fiecărei anghinare. Taiăți sferul de sus al fiecărei anghinare. Aruncați frunzele deteriorate. Ungeți suprafețele tăiate cu o felie de lămâie. Puneți feliile de lămâie în coș. Adăugați crenguțele de ierburi. Adăugați usturoiul. Puneți anghinarea deasupra. Umpleți cu apă până la nivelul 2 de pe scala din stânga, în interiorul vasului. Puneți coșul peste vas. Închideți capacul. Selectați  din meniu și apăsați . Anghinarele sunt gătite atunci când frunzele exterioare pot fi îndepărtate cu ușurință. Serviți-le calde sau reci, cu sos de salată. Senzațional!





CHILLI DE LEGUME ȘI CUȘCUȘ

GĂTIRE LENTĂ 

1	ceapă roșie, tocată	1 	ulei de măsline
1	ceapă albă, tocată	1 	fasole albă
2 	usturoi, curătat și tocat	1 	cannellini boabe
1	ardei roșu, fără sămburi și tocat	1 	jalapenos verde
1	ardei galben, fără sămburi și tocat	1 	fasole
1	ardei portocaliu, fără sămburi și tocat	1 	roșii tăiate
1 	coriandru măcinat	2 	chimen măcinat
1 	piure de roșii	1 	zahăr
850 ml	cub de legume	2 	pudră de chilli
2 	sos de roșii iute	2 	oregano uscate
120-140 ml	cușcuș		









a se servi cu:



brânză rasă	smântână
o legătură mică de coriandru, tocat	

Deschideți capacul. Adăugați uleiul. Selectați  din meniu și apăsați . Adăugați ceapa și usturoiul. Gătiți până când ceapa se înmoaie. Uscați fasolea și adăugați-o. Lăsați cușcușul deoparte. Adăugați celelalte ingrediente. Apăsați  de două ori, pentru a opri programul. Închideți capacul. Selectați . Adăugați cușcușul cu 30 de minute înainte de terminarea timpului de preparare. Dacă timpul de preparare s-a terminat deja, selectați  din meniu și gătiți timp de încă aproximativ 20 de minute. Serviți într-un castron, cu un pumn de brânză, o ploaie de smântână și un pic de coriandru proaspăt. Pentru a obține un chilli vegetarian clasic, omiteți cușcușul.



TAJINE DE PEȘTE ÎN STIL MAROCAN





PEȘTE 

2 	usturoi, curătat și tocat	1	ceapă, tocată
1	ardei roșu, fără sămburi și tocat	2 	țelină verde, tocată
2	roșii tăiate	1 	chimen măcinat
1 	ghimbir măcinat	1 	carcuma
1	băț de scorțișoară	1 	pastă de harissa
120 ml	vin alb	1 	piure de roșii
120 ml	supă de pește	1	lămâie
675 g	pește (cod/eglefin/somon)	1 	ceapă verde
1	o legătură mică de coriandru, tocat		sare și piper



Lăsați coriandrul deoparte. Deschideți capacul. Adăugați celelalte ingrediente. Închideți capacul. Selectați  din meniu și apăsați . Lăsați la gătit până când peștele devine pufos (40-60 minute). Apăsați  de două ori, pentru a opri programul. Adăugați coriandrul. Condimentați și serviți. Acest preparat ar merge de minune cu cușcuș.

SUPĂ DE MAZĂRE ȘI CIOLAN

1150 ml	supă de pui
225 g	mazăre
1 	țelină verde, tocată
1 	cimbru, tocat mărunt
1	ciolan

Deschideți capacul. Adăugați supa. Selectați  din meniu și apăsați . Lăsați să dea în clocot, amestecând. Fierbeți la loc mic timp de 10 minute. Adăugați celelalte ingrediente. Apăsați  de două ori, pentru a opri programul. Închideți capacul. Selectați . Așteptați până când programul se termină. Scoateți ciolanul. Aruncați pielea și oasele. Tăiați carnea în bucăți. Aruncați frunza de dafin. Decorticați mazărea cu partea din spate a unei linguri de lemn. Adăugați carnea. Condimentați și serviți. Raiul într-un vas!



GĂTIRE LENTĂ





1	ceapă, tocată mărunt
1	morcov, tocat
2 	usturoi (pisat)
1 	foi de dafin
	piper negru

GHIVECI IRLANDEZ (STEW) ȘI GĂLUȘTE DE BRÂNZĂ DE CAPRĂ

FIERBERE ÎNĂBUȘITĂ





pentru ghiveci:

1.8 kg	umăr de miel (gătit)
250 g	șuncă feliată
950 ml	supă de miel
1	ceapă albă, tocată
2 	țelină verde, tocată
2 	piure de roșii





1 	ulei de măsline
3 	usturoi (pisat)
	sare și piper
2	morcovi, tocați
2 	rozmarin, tocat
1 	făină de porumb

pentru găluște:

100 g	făină cu agent de creștere
50 g	seu
75 ml	apă
40 g	brânză de capră (slabă)
1 	maghiran uscat

1 	praf de copt
1 	sare
1 	pătrunjel uscat
1 	cimbru uscat
1 	piper negru

pentru ghiveci:

Îndepărtați carnea de pe os. Tăiați carnea și șunca în bucățele mici. Deschideți capacul. Selectați  din meniu și apăsați . Adăugați supa. Lăsați să dea în clocot, amestecând. Fierbeți la loc mic timp de 10 minute. Transferați supa într-un vas. Adăugați uleiul. Adăugați ceapa și fierbeți înăbușit până se înmoaie. Adăugați carnea, usturoiul, ierburile și alte legume și gătiți timp de 5 minute. Adăugați supa. Adăugați piureul de roșii. Apăsați  de două ori, pentru a opri programul. Închideți capacul. Selectați .

pentru găluște:

Amestecați toate ingredientele cu mâna. Împărțiți amestecul în 6 mingi. Lăsați să se odihnească timp de 20 minute.



pentru finalizare:



Într-o cană, faceți o pastă moale din făină de porumb și puțină apă. La 30 de minute înainte de terminarea timpului de gătit, deschideți capacul. Amestecați pasta în ghiveci. Adăugați găluștele. Închideți capacul. Așteptați până când programul se termină, apoi serviți. Un castron fabulos de mâncare pentru momente grele!

- Dacă nu aveți carne de miel gătită, puteți folosi carne de miel crudă, folosind programul de gătire lentă în locul celui pentru ghiveci, apoi continuând cu momentul preparării găluștelor.

ARPAÇAȘ ȘI FASOLE BORLOTTI ÎNTR-O SINGURĂ FARFURIE





FIERBERE ÎNĂBUȘITĂ

1 	ulei de măsline
175 g	arpacaș
1 	roșii tăiate
1000 ml	cub de legume
125 ml	vin roșu sec

1 	fasole borlotti
1	ceapă, tocată mărunt
1 	piure de roșii
2 	pătrunjel (tocat)
	sare și piper



a se servi cu:

ulei de chilli iute (opțional)

Deschideți capacul. Selectați  din meniu și apăsați . Adăugați supa. Lăsați să dea în clocot, amestecând. Fierbeți la loc mic timp de 10 minute. Transferați supa într-un vas. Adăugați uleiul. Adăugați ceapa și fierbeți înăbușit până se înmoaie. Adăugați vinul și lăsați la gătit câteva minute. Adăugați arpacășul și amestecați până când începe să prindă culoarea vinului. Uscați fasolea și adăugați-o. Adăugați roșiile. Adăugați supa. Apăsați  de două ori, pentru a opri programul. Închideți capacul. Selectați . La 30 de minute înainte de terminarea timpului de gătit, deschideți capacul. Verificați cantitatea de lichid din vas. Adăugați 150 ml de apă fierbinte dacă este necesar. Închideți capacul. Așteptați până când programul se termină. Serviți cu pâine proaspătă crocantă și un pic de ulei de chilli iute.



NEGRESE DE CIOCOLATĂ

PRĂJITURĂ

170 g	unt fără sare	3	
340 g	zahăr	1	 esență de vanilie
170 g	puđră de cacao	1	 sare
110 g	dropsuri cu lapte și ciocolată	75 g	făină simplă

a se servi cu:



înghețată de vanilie (opțional)

Topiți untul într-o cratiță, la foc mic. Tapetați vasul cu folie unsă cu unt. Bateți untul topit, zahărul, pudra de cacao, făina, ouăle, vanilia și sarea într-un castron. Incorporați dropsurile de ciocolată. Puneți aluatul în folia din interiorul vasului. Închideți capacul. Selectați  din meniu. Setați timpul de preparare la 1 oră și 30 de minute. Apăsați butonul . Prăjitura trebuie să fie tare pe margini și ușor cleioasă în centru. Serviți prăjitura caldă, punând deasupra înghețată.

COZONAC CU SIROP

ABUR





115 g	unt	2	
100 g	zahăr pudră	¼	 esență de vanilie
175 g	făină cu agent de creștere	2	 lapte
4	sirop din trestie de zahăr		

Bateți ouăle într-un castron. Bateți untul și zahărul într-un vas. Adăugați treptat ouăle, apoi vanilia, apoi făina. Amestecați cu lapte. Ungeți o tavă termorezistentă de 1200 ml. Puneți siropul pe fundul tăvii termorezistente și puneți amestecul deasupra. Acoperiți cu hârtie de copt, apoi cu folie, și legați partea de sus cu o sfoară. Deschideți capacul. Introduceți tava termorezistentă în vasul aparatului. Adăugați suficientă apă clocotită în aparat cât să ajungă la 3 cm deasupra părții de sus a tăvii termorezistente. Închideți capacul. Selectați  din meniu. Setați timpul de preparare la 1 oră și 30 de minute. Apăsați butonul . Așteptați până când programul se termină. Transferați conținutul pe o farfurie și serviți cald. Un cozonac excelent, pentru orice perioadă a anului!

PÂINE ALBĂ

PÂINE

1	sirop din trestie de zahăr	1	unt
320 ml	lapte	1	drojdie uscată
500 g	făină albă normală	1	sare

Deschideți capacul. Adăugați laptele. Selectați  din meniu și apăsați . Lăsați laptele să se încălzească până începe să formeze bule pe margini. Transferați laptele într-un vas. Apăsați  de două ori, pentru a opri programul. Lăsați laptele să se răcească la o temperatură între 37°C și 45°C. Topiți untul într-o cratiță, la foc mic. Amestecați făina și sarea într-un castron. Adăugați drojdie, unt și sirop. Adăugați laptele și frământați pentru a obține o minge de aluat. Dacă amestecul este foarte lipicios, mai adăugați puțină făină. Acoperiți și lăsați într-un loc cald timp de 10 minute. Frământați din nou. Acoperiți și lăsați într-un loc cald timp de 10 minute. Deschideți capacul. Selectați  din meniu și apăsați . Închideți capacul. La 30 de minute înainte de terminarea timpului de gătit, deschideți capacul. Întoarceți pâine. Acest lucru va rumeni puțin partea de sus a pâinii și o va rumeni. Așteptați până când programul se termină. Serviți cu bucăți de unt.

PÂINE CU BICARBONAT



1 amestec de pâine cu bicarbonat
350 ml apă

unt

Deschideți capacul. Ungeți vasul cu unt. Selectați din meniu. Închideți capacul. Setați timpul de preparare la 2 ore și 15 minute. Apăsăți butonul . Lăsați-l să se încălzească. Puneți amestecul de pâine cu bicarbonat într-un vas. Adăugați apă. Amestecați cu mâna, formând o minge. Deschideți capacul. Puneți aluatul în vas. Împărțiți aluatul în sferturi, cu o spatulă de plastic. Închideți capacul. La 30 de minute înainte de terminarea timpului de gătit, deschideți capacul. Întoarceți pâine. Acest lucru va rumeni puțin partea de sus a pâinii și o va rumeni. Așteptați până când programul se termină. Răciți blatul pe un grilaj metalic. Serviți cu unt sărat sau ca atare, ori la mâncare.

PORRIDGE (TERCI DE OVĂZ)

2 fulgi de ovăz
1/4 sare

a se servi cu:

zahăr brun

PORRIDGE (TERCI DE OVĂZ)/RIZOTO

apă
2 zahăr

lapte / smântână slabă

Deschideți capacul. Adăugați ovăzul, sarea și zahărul. Umpleți cu apă până la nivelul 1/2 de pe scala din dreapta, în interiorul vasului. Închideți capacul. Selectați din meniu și apăsați . Așteptați până când programul se termină. Serviți cu lapte sau smântână. Presărați deasupra zahăr brun. Dacă doriți, puteți adăuga caise uscate bucăți sau jumătăți de prune (fără sâmburi) cu 15 înainte de terminarea timpului de preparare. Resturile de porridge pot fi păstrate la frigider până la 2 zile, apoi pot fi încălzite.

PORRIDGE CU NUCI

120 ml lapte
1/2 fulgi de ovăz
apă

a se servi cu:

sirop din trestie de zahăr

PORRIDGE (TERCI DE OVĂZ)/RIZOTO

3 nucă de cocos deshidratată
1 scorțișoară măcinată

migdale

Deschideți capacul. Adăugați fulgii de ovăz, scorțișoara, nuca de cocos și laptele. Umpleți cu apă până la nivelul 1/2 de pe scala din dreapta, în interiorul vasului. Închideți capacul. Selectați din meniu și apăsați . Așteptați până când programul se termină. Presărați sirop din trestie de zahăr și adăugați migdalele deasupra.

MÂNCARE DE PIEPT DE VITĂ

1 kg piept de vită
2 usturoi, curățat și tocat
50 g cârnaț chorizo, feliat
2 ceapă roșie, tocată
600 ml supă de vită
2 amestec de ierburi uscate
6-8 cartofi (mici)
2 sos Worcestershire





Nu curățați cartofii de coajă. Taiăți cartofii, morcovii și țelina în bucăți. Condimentați pieptul cu sare și piper. Deschideți capacul. Selectați din meniu și apăsați . Adăugați supa. Lăsați să dea în clocot, amestecând. Fierbeți la loc mic timp de 10 minute. Transferați supa într-un vas. Gătiți chorizo timp de 2 minute. Adăugați carnea. Lăsați să se rumenească peste tot. Adăugați ceapa, usturoiul, cartofii, țelina și morcovii. Dacă doriți să folosiți și alte legume, le puteți adăuga. Gătiți până când ceapa se înmoaie. Adăugați supa. Adăugați celelalte ingrediente. Apăsăți de două ori, pentru a opri programul. Selectați . Așteptați până când programul se termină, apoi serviți. Timpul de preparare de 8 ore nu va dăuna, însă preparatul va fi probabil gata după 5 ore.

GĂTIRE LENTĂ

2 piure de roșii
2 foi de dafin
2 morcovi
3 țelină
2 rozmarin, tocat
1 roșii tăiate
sare și piper

OREZ SAVUROS





OREZ





2 	orez		apă
1	cub pentru ciorbă (legume)	2	morcovi, tocați
1	ardei roșu, fără sămburi și tocat	2 	țelină verde, tocată
1 	carcuma	1 	mazăre (opțional)

Deschideți capacul. Puneți orezul în vas. Umpleți cu apă până la nivelul 2 de pe scala din stânga, în interiorul vasului. Zdrobiți cubul de supă și adăugați-l în apă, amestecând. Adăugați celelalte ingrediente. Închideți capacul. Selectați . Așteptați până când programul se termină, m apoi serviți. Dacă orezul nu este bine făcut, lăsați-l câteva minute, cu capacul închis, pentru a se găti la abur.

SUPĂ DE ROȘII







SUPĂ





1	ceapă, tocată	1 	ulei de măsline
1 	roșii tăiate	2	roșii tăiate
1	ardei roșu, fără sămburi și tocat	2	cartofi,
550 ml	supă de pui	1 	piure de roșii
1 	amestec de ierburi uscate	1 	piper negru

Deschideți capacul. Adăugați supa. Selectați  din meniu și apăsați . Lăsați să dea în clocot, amestecând. Fierbeți la loc mic timp de 10 minute. Transferați supa într-un vas. Apăsați  de două ori, pentru a opri programul. Curățați și tocați cartofii. Selectați  din meniu și apăsați . Adăugați uleiul. Adăugați ceapa și ardeiul dulce. Gătiți până când ceapa se înmoaie. Adăugați supa. Adăugați celelalte ingrediente. Închideți capacul. Așteptați până când programul se termină. Condimentați. Serviți cu pâine crocantă.

SUPĂ DE CHORIZO, VARZĂ ȘI MĂR







SUPĂ



¼	cârnat chorizo, tocat mărunt	1	ceapă, tocată mărunt
1	măr	2	morcovi, tocați
2 	țelină verde, tocată	2	roșii tăiate
¼	varză proaspătă, tocată mărunt	1 	piure de roșii
2 	usturoi, curătat și tocat	1 	piper cayenne
1 	sare	1 	piper negru
850 ml	cub de legume		

Deschideți capacul. Selectați  din meniu și apăsați . Gătiți chorizo timp de 2 minute. Adăugați ceapa și usturoiul. Gătiți până când ceapa se înmoaie. Curățați, scoateți cotorul și tăiați mărul. Adăugați celelalte ingrediente. Apăsați  de două ori, pentru a opri programul. Închideți capacul. Selectați  din meniu și apăsați . Așteptați până când programul se termină. Este o supă excelentă dacă o lăsați peste noapte la frigider, deoarece aromele se vor intensifica.

PUI CU ROȘII ȘI CIUPERCI

CARNE

2	piept de pui, dezosat și fără piele	1 	ulei de măsline
450 g	ciuperci brune, tocate	1 	roșii tăiate
2 	usturoi, curătat și tocat	1 	suc de roșii
1 	sos Worcestershire	1 	oregano uscate
	sare și piper		



Deschideți capacul. Selectați  din meniu și apăsați . Adăugați uleiul. Condimentați pieptul de pui cu sare și piper și puneți-l în vas. Întoarceți carnea pentru a se găti pe ambele părți. Adăugați usturoiul și ciupercile. Gătiți timp de 3-4 minute, întorcând puilul o dată. Adăugați roșiile, sosul Worcestershire, sosul de roșii și oregano. Lăsați în continuare la gătit, întorcând puilul încă o dată. Verificați dacă puilul este gata. Serviți cu paste, cartofi sau orez. O masă de casă rapidă și gustoasă.

COSTIȚE CU BERE BRUNĂ (STOUT), SIROP DE ARȚAR ȘI SOIA



1 kg	costițe de porc
350 ml	Guinness / stout
140 ml	supă de vită / supă de porc
60 ml	sirop de arțar / miere

1	ceapă, tocată
1	ulei de măsline
3	usturoi, curățat și tocat
2	sos brun de soia

Deschideți capacul. Selectați  din meniu. Adăugați uleiul. Setati timpul de preparare la 1 oră și 45 de minute. Apăsati butonul . Adăugați costițele și rumeniți-le 5 minute - întorcându-le din când în când. Scoateți costițele. Adăugați ceapa și usturoiul. Gătiți până când ceapa se înmoaie. Puneți costițele înapoi în vas. Adăugați Guinness, supă, sirop de arțar și sos de soia. Închideți capacul. Așteptați până când programul se termină. Condimentați și serviți. Un aperitiv excelent sau o gustare ori un prânz.

RIZOTO CU SFECLĂ ROȘIE

400 g	sfeclă roșie
250 g	orez arbori/rizoto
250 ml	vin alb
900 ml	cub de legume / supă de pui





pentru finalizare:

100 ml	iaurt
1	unt

PORRIDGE (TERCI DE OVĂZ)/RIZOTO

2	ulei de măsline
1	ceapă, tocată mărunt
2	usturoi, curățat și tocat
1	cimbru, tocat mărunt

1	pătrunjel (tocat)
---	-------------------

Deschideți capacul. Selectați  din meniu și apăsați . Adăugați supa. Lăsați să dea în clocot, amestecând. Fierbeți la loc mic timp de 10 minute. Transferați supa într-un vas. Apăsati  de două ori, pentru a opri programul. Selectați  din meniu și apăsați . Lăsați-l să se încălzească. Îndepărtați pielea de pe sfecla roșie și tăiați-o în cuburi de 1 cm. Puneți sfecla roșie, usturoiul și ceapa într-un vas. Gătiți până când ceapa se înmoaie. Amestecați orezul. Închideți capacul și lăsați la gătit 3-4 minute. Deschideți capacul. Amestecați vinul. Închideți capacul și lăsați la gătit 3-4 minute. Deschideți capacul. Adăugați cimbrul. Adăugați supa. Închideți capacul. Așteptați până când programul se termină. Verificați orezul - ar trebui să fie puțin crocant, însă să nu fie tare. Dacă nu este încă gata, adăugați puțină apă și lăsați-l încă câteva minute. Adăugați untul, amestecând - acesta îi va conferi luciul rizotoului. Serviți cu puțin iaurt și o ploaie de pătrunjel. Este foarte bun ca aperitiv sau ca masă ușoară.

Прочетете инструкциите, запазете ги и ги предавайте, ако предавате и уреда. Отстранете всички опаковки преди употреба.



ВАЖНИ ПРЕДПАЗНИ МЕРКИ

Следвайте основните мерки за безопасност, включително:

Този уред може да се използва от деца над 8-годишна възраст, както и от хора с ограничени физически, сетивни или умствени способности, или липса на опит и познания, ако са нагледжани/инструирани и разбират опасностите с това. С уреда не трябва да играят деца.

Почистването и поддръжката не трябва да се извършват от деца, освен ако те не са над 8-годишна възраст и някой ги наглежда. Пазете уреда и кабела от деца под 8-годишна възраст.

Ако конекторът или кабелът са повредени, трябва да бъдат сменени със специален механизъм, доставен от производителя или негов представител.

-  Не використовуйте цей пристрій поблизу ван, душів, басейнів та інших резервуарів із водою.
-  Неправилната употреба на уреда може да доведе до нараняване.
-  Повърхността на уреда ще се нагорещи. Остатъчната топлина ще поддържа повърхностите нагорещени след употреба.
 - Не слагайте замразено месо или птиче месо в уреда – размразете напълно преди употреба.
 - Гответе месо, домашни птици и производни (кайма, шницели и др.), докато при бодване потече сок без кръв. Рибата се готви, докато месото добие непрозрачен вид.
 - Не се опитвайте да готвите нищо в тялото на съда за готвене - гответе само в подвижната купа.
 - Не пълнете над обозначението „max“ (макс.).
 - Не покривайте уреда и не поставяйте нищо отгоре му.
 - Извадете щепсела от електрозахранването, след това извадете конектора от входа за електричество на уреда.
 - Когато не използвате уреда, изключете от контакта.
 - Не използвайте аксесоари или приставки, различни от тези, предоставени от нас.
 - Не използвайте уреда за други цели, освен тези, описани в настоящите инструкции.
 - Не използвайте уреда, ако е повреден или не работи изрядно.

САМО ЗА ДОМАШНА УПОТРЕБА

ИЛЮСТРАЦИИ



- | | |
|-------------------------|-------------------|
| 1. Контролен панел | 5. Мерителна чаша |
| 2. Капак | 6. Кош |
| 3. Блокировка на капака | 7. Купа |
| 4. Вътрешен капак | 8. конектор |

ПОДГОТОВКА



1. Поставете уреда на твърда, равна, топлоустойчива повърхност.
2. Не използвайте уреда в близост или под завеси, рафтове, шкафове или нещо друго, което може да бъде повредено от излизащата пара.

3. Дръжте под ръка ръкавици за фурна (или кърпа), подложка или чиния, за да сложите купата след готвене.
4. Поставете купата в съда за готвене.
5. Осигурете на купата еднакво разстояние от всички страни, за по-добър контакт с елемента.



ОРИЗ

1. Ако желаете да поставите ориза в купата, използвайте мерителната чаша.
2. Не сипвайте повече от 10 чаши ориз.
3. Използвайте скалата отляво, която се намира във вътрешната част на купата и е маркирана от 2 до 10.
4. Напълнете купата с вода до цифрата, отговаряща на броя използвани чаши с ориз.
5. Затворете капака.
6. Натиснете бутон . Бутонът ще светне.
7. Външните сегменти на екрана започват да мигат, докато храната се затопля.
8. След това на екрана се показва оставащото време за готвене (13 минути) и започва отброяване.
9. В края на времето за готвене уредът преминава в режим "поддържане на топло".
10. Лампичката  ще светне.
11. Отворете капака.
12. Извадете купата и я поставете върху подложка или чиния.
13. Натиснете бутон .
14. Използвайте лъжица, за да обърнете и смесите ориза, за да може да излезе парата.
15. Понякога тази част от ориза, която е в контакт с купата образува коричка.
16. Ако не я искате, след сервиране на ориза я премахнете с лъжица

БАВНО ГОТВЕНЕ





1. Запечено месо и зеленчуци (вижте "ЗАПИЧАНЕ/ЛЕКО ЗАПЪРЖВАНЕ/ОМЕКВАНЕ/ВАРЕНЕ").
2. Изчакайте докато течността за готвене започне да ври (вижте "ЗАПИЧАНЕ/ЛЕКО ЗАПЪРЖВАНЕ/ОМЕКВАНЕ/ВАРЕНЕ").
3. Оставете твърдите съставки в купата, след което добавете течността за готвене.
4. Затворете капака.
5. Натиснете бутон . Бутонът ще светне.
6. На екрана се показват 8 часа и започва отброяване.
7. В края на времето за готвене уредът преминава в режим "поддържане на топло".
8. Лампичката  ще светне.
9. Натиснете бутон . Отворете капака. Извадете храната.

ЗАДУШАВАНЕ





1. Запечено месо и зеленчуци (вижте "ЗАПИЧАНЕ/ЛЕКО ЗАПЪРЖВАНЕ/ОМЕКВАНЕ/ВАРЕНЕ").
2. Изчакайте докато течността за готвене започне да ври (вижте "ЗАПИЧАНЕ/ЛЕКО ЗАПЪРЖВАНЕ/ОМЕКВАНЕ/ВАРЕНЕ").
3. Оставете твърдите съставки в купата, след което добавете течността за готвене.
4. Затворете капака.
5. Натиснете бутон . Бутонът ще светне.
6. На екрана се показва 1 час и започва отброяване.
7. В края на времето за готвене уредът преминава в режим "поддържане на топло".
8. Лампичката  ще светне.
9. Натиснете бутон . Отворете капака. Извадете храната.

МЕСО

1. Натрийте готварско олио по цялата храна.
2. Натрийте подправки по повърхността на храната.

3. Сложете една супена лъжица готварско олио в купата.
4. Поставете храната в купата.
5. Затворете капака.
6. Времето за приготвяне зависи от големината на продуктите.
7. Не приготвяйте повече от около 500 г храна наведнъж.
8. Съветваме ви да задавате време за готвене от 10 минути + 10 минути на 100 г говеждо месо.
9. Свинското месо или месото от домашни птици трябва да се готвят в продължение на не по-малко от 5, 10, 15, 20, 25, 30 минути.
10. Използвайте бутона , за да изберете  от менюто.
11. Изберете желаното време за готвене. Времето по подразбиране е 20 минути.
12. Можете да използвате само бутоните h (час) и min (минути), докато времето, показано на екрана мига.
13. Използвайте бутона min, за да прехвърлите опциите на екрана (10, 15, 20, 25, 5, 10, 15, 20, 25, 30, 35, 40, 45, 50 и 55).
14. Ако желаете да готвите в продължение на 1 час, натиснете бутона h.
15. За да отмените 1-часовата настройка, отново натиснете бутона h, докато времето, показано на екрана мига.
 - Ако не извършвате никакви действия в продължение на 2 минути, уредът ще се прехвърли в режим на готовност.
16. Когато сте задали времето, натиснете .
17. Екранът започва отброяване.
18. В края на времето за готвене уредът преминава в режим "поддържане на топло".
19. Лампичката  ще светне.
20. Натиснете бутон . Отворете капака. Извадете храната.

СУПА

1. Запечено месо и зеленчуци (вижте "ЗАПИЧАНЕ/ЛЕКО ЗАПЪРЖВАНЕ/ОМЕКВАНЕ/ВАРЕНЕ").
2. Оставете твърдите съставки в купата, след което добавете течността за готвене.
3. Затворете капака.
4. Използвайте бутона , за да изберете  от менюто.
5. Изберете желаното време за готвене. Времето по подразбиране е 1 час.
6. Можете да използвате само бутоните h (час) и min (минути), докато времето, показано на екрана мига.
7. Използвайте бутона min, за да прехвърлите опциите на екрана (10, 15, 20, 25, 5, 10, 15, 20, 25, 30, 35, 40, 45, 50 и 55).
8. Използвайте бутона h, за да прехвърлите опциите на екрана (1, 2, 3, 4 и 5).
9. За да отмените 5-часовата настройка, отново натиснете бутона h, докато времето, показано на екрана мига.
 - Ако не извършвате никакви действия в продължение на 2 минути, уредът ще се прехвърли в режим на готовност.
10. Можете да използвате таймера с тази програма (вижте ТАЙМЕР).
11. Натиснете бутон .
12. Екранът започва отброяване.
13. В края на времето за готвене уредът преминава в режим "поддържане на топло".
14. Лампичката  ще светне.
15. Натиснете бутон . Отворете капака. Извадете храната.

КИСЕЛО МЛЯКО

Закваска от кисело мляко

Може да използвате 5, 10, 15, 20, 25, 30 мл. (2 супени лъжици):

- Неароматизирано „живо“ кисело мляко – трябва да е свежо (търсете дълъг срок на годност).
Различните марки дават различни резултати.

Предварително приготвено кисело мляко.

- Бактериите отслабват с течение на времето, затова може да правите това само 10 пъти преди да ползвате нова закваска.





Лиофилизирана закваска от аптека или магазин за здравословна храна.

- Ако инструкциите на пакета се различават от наръчника, следвайте тези на пакета.



Мляко

- Нужен ви е 1 литър мляко.
- Пълномасленото мляко отдава по-гъсто кисело мляко отколкото нискомасленото.
- За да го направите още по-гъсто, можете да добавите до 8 супени лъжици мляко на прах към течното.
- Също така, може да използвате разтворено мляко на прах, или кондензирано мляко.

Приготвяне на кисело мляко

1. Трябва да унищожите бактериите в млякото, за да предотвратите контакт с бактериите в закваската на киселото мляко.
2. Докато затопляте млякото, оставете закваската да достигне стайната температура.
3. Отворете капака.
4. Използвайте програмата за ГОТВЕНЕ НА ПАРА (ЗАПИЧАНЕ/ЛЕКО ЗАПЪРЖВАНЕ/ОМЕКВАНЕ/ВАРЕНЕ), за да затоплите млякото до степен точно преди да заври.
5. Оставете млякото да се затопли, докато по краищата започнат да се появяват балончета.
6. Оставете млякото да се охлади между 37°C и 45°C.
7. Добавете закваската към млякото, като в това време разбърквате.
8. Те трябва да са изцяло смесени, в противен случай млякото ще стане на бучки.
9. Затворете капака.
10. Използвайте бутон , за да изберете  от менюто.
11. Изберете желаното време за готвене. Времето по подразбиране е 8 часа.
12. Можете да използвате само бутоните h (час) и min (минути), докато времето, показано на екрана мига.
13. Използвайте бутон min, за да прехвърлите опциите на екрана (10, 15, 20, 25, 5, 10, 15, 20, 25, 30, 35, 40, 45, 50 и 55).
14. Използвайте бутон h, за да прехвърлите опциите на екрана (6, 7, 8, 9 и 10).
15. За да отмените 10-часовата настройка, отново натиснете бутон h, докато времето, показано на екрана мига.
- Ако не извършвате никакви действия в продължение на 2 минути, уредът ще се прехвърли в режим на готовност.
16. Можете да използвате таймера с тази програма (вижте ТАЙМЕР).
17. Натиснете бутон .
18. Екранът започва отброяване.
19. В края на времето за готвене уредът преминава в режим на готовност.
20. Той няма да запази киселото мляко затоплено.
21. Натиснете бутон . Отворете капака. Извадете храната.

ХЛЯБ

1. Размразете замразеното тесто изцяло преди употреба.
2. Не приготвяйте повече от около 500 г храна наведнъж.
3. Намажете купата с готварско олио.
4. Поставете тестото в купата.
5. Затворете капака.
6. Използвайте бутон , за да изберете  от менюто.
7. Изберете желаното време за готвене. Времето по подразбиране е 3 часа.
8. Можете да използвате само бутоните h (час) и min (минути), докато времето, показано на екрана мига.
9. Използвайте бутон min, за да прехвърлите опциите на екрана (10, 15, 20, 25, 5, 10, 15, 20, 25, 30, 35, 40, 45, 50 и 55).
10. Използвайте бутон h, за да прехвърлите опциите на екрана (1, 2, 3, 4, 5 и 6).



11. За да отмените 6-часовата настройка, отново натиснете бутона h, докато времето, показано на екрана мига.
 - Ако не извършвате никакви действия в продължение на 2 минути, уредът ще се прехвърли в режим на готовност.
 12. Можете да използвате таймера с тази програма (вижте ТАЙМЕР).
 13. Натиснете бутон ◊.
 14. Екранът започва отброяване.
 15. В края на времето за готвене уредът преминава в режим “поддържане на топло”.
 16. Лампичката ☹ ще светне.
 17. Натиснете бутон ⓧ. Отворете капака. Извадете храната.
-



РИБА

1. Натрийте готварско олио по цялата храна.
 2. Натрийте подправки по повърхността на храната.
 3. Сложете една супена лъжица готварско олио в купата.
 4. Поставете храната в купата.
 5. Затворете капака.
 6. Времето за приготвяне зависи от големината на продуктите.
 7. Не приготвяйте повече от около 500 г храна наведнъж.
 8. Предлагаме време за готвене от 10 минути на 100 г храна.
 9. Използвайте бутона ? , за да изберете 🐟 от менюто.
 10. Изберете желаното време за готвене. Времето по подразбиране е 20 минути.
 11. Можете да използвате само бутоните h (час) и min (минути), докато времето, показано на екрана мига.
 12. Използвайте бутона min, за да прехвърлите опциите на екрана (10, 15, 20, 25, 5, 10, 15, 20, 25, 30, 35, 40, 45, 50 и 55).
 13. Ако желаете да готвите в продължение на 1 час, натиснете бутона h.
 14. За да отмените 1-часовата настройка, отново натиснете бутона h, докато времето, показано на екрана мига.
 - Ако не извършвате никакви действия в продължение на 2 минути, уредът ще се прехвърли в режим на готовност.
 15. Когато сте задали времето, натиснете ◊ .
 16. Екранът започва отброяване.
 17. В края на времето за готвене уредът преминава в режим “поддържане на топло”.
 18. Лампичката ☹ ще светне.
 19. Препоръчваме да отстраните храната веднага щом се е сготвила, за да не се стигне до изсъхване.
 20. Натиснете бутон ⓧ. Отворете капака. Извадете храната.
-

ГОТВЕНЕ НА ПАРА

1. Напълнете купата със студена вода до маркировката б.
2. Поставете коша върху горната част на купата и сложете храната в него.
3. За равномерно готвене, нарежете храната на приблизително еднакви парчета.
4. Ако готвите грах или нещо друго, което може да се разпилее и да падне във водата, обвийте в алуминиево фолио.
5. Внимавайте, когато премахвате фолиото – сложете ръкавици за фурна и използвайте пластмасови щипки/лъжици.
6. Затворете капака.
7. Използвайте бутона ? , за да изберете 🍲 от менюто.
8. Изберете желаното време за готвене. Времето по подразбиране е 30 минути.
 - Те трябва да се приготвят в рамките на времето по подразбиране:

Храна (прясна)	Количество
Грах	200g
Брюкселско зеле	200g
Моркови (на кръгчета)	200g
Картофи (на кубчета)	400g
Броколи	200g
Четвърт	Четвърт
Царевица (кочан)	2

9. Можете да използвате само бутоните h (час) и min (минути), докато времето, показано на екрана мига.
10. Използвайте бутон min, за да прехвърлите опциите на екрана (5, 10, 15, 20, 25, 30, 35, 40, 45, 50 и 55).
11. Използвайте бутон h, за да прехвърлите опциите на екрана (1 и 2).
12. За да отмените 2-часовата настройка, отново натиснете бутона h, докато времето, показано на екрана мига.
 - Ако не извършвате никакви действия в продължение на 2 минути, уредът ще се прехвърли в режим на готовност.
13. Можете да използвате таймера с тази програма (вижте ТАЙМЕР).
14. Натиснете бутон .
15. Екранът започва отброяване.
16. В края на времето за готвене уредът преминава в режим "поддържане на топло".
17. Лампичката  ще светне.
18. Препоръчваме да отстраните храната веднага щом се е сготвила, за да не се стигне до навлажняване.
19. Натиснете бутон . Отворете капака. Извадете храната.

ЗАПИЧАНЕ/ЛЕКО ЗАПЪРЖВАНЕ/ОМЕКВАНЕ/ВАРЕНЕ

- Можете да използвате програмата за ГОТВЕНЕ НА ПАРА  на настройката ѝ по подразбиране, при отворен капак, като тиган за високотемпературна обработка в продължение на 5, 10, 15, 20, 25, 30 минути, преди да започнете да готвите с друга програма.
- Използвайте с малко олио за запичане на месо и зеленчуци, за леко запържване, за омекване на лук, целина, праз и др.
- Използвайте с вода или продукти за предварително затопляне на готварски течности.
- Когато превключите към основната програма, уредът вече е затоплен и някои или всички ваши съставки ще са вече в купата.
- Тогава не е необходимо да измивате тигана, който сте използвали за подготовка.

ОВЕСЕНА КАША/РИЗОТО

Използвайте мерителната чаша, за да добавите зърнените храни (ориз, овес, ечемик и др.) в купата.





Овесена каша

- Използвайте скалата отясно в самата купа, която е маркирана от 1/2 до 1 1/2.
- Не пълнете над обозначението „max“ (макс.).

Songee (вид овесена каша)

1. Използвайте централната скала в самата купа, която е маркирана от 1 до 3.
2. Не пълнете над обозначението „max“ (макс.).
3. Напълнете купата с вода до цифрата, отговаряща на броя чаши със зърнени храни.
4. Затворете капака.







5. Използвайте бутона , за да изберете  от менюто.
6. Изберете желаното време за готвене. Времето по подразбиране е 1 час.
7. Можете да използвате само бутоните h (час) и min (минути), докато времето, показано на екрана мига.
8. Използвайте бутона min, за да прехвърлите опциите на екрана (5, 10, 15, 20, 25, 30, 35, 40, 45, 50 и 55).
9. Използвайте бутона h, за да прехвърлите опциите на екрана (1, 2, 3 и 4).
10. За да отмените 4-часовата настройка, отново натиснете бутона h, докато времето, показано на екрана мига.
 - Ако не извършвате никакви действия в продължение на 2 минути, уредът ще се прехвърли в режим на готовност.
11. Можете да използвате таймера с тази програма (вижте ТАЙМЕР).
12. Натиснете бутон .
13. Екранът започва отброяване.
14. В края на времето за готвене уредът преминава в режим "поддържане на топло".
15. Лампичката  ще светне.
16. Натиснете бутон . Отворете капака. Извадете храната.



Ризото

Изпълнете рецептата, посочена по-нататък в брошурата.









ТОРТА

1. Размразете замразеното тесто изцяло преди употреба.
2. Не запълвайте повече от половината купа.
3. Намажете купата с готварско олио.
4. Поставете тестото в купата.
5. Затворете капака.
6. Използвайте бутона , за да изберете  от менюто.
7. Изберете желаното време за готвене. Времето по подразбиране е 40 минути.
8. Времето по подразбиране е 40 минути.
9. Можете да използвате само бутоните h (час) и min (минути), докато времето, показано на екрана мига.
10. Използвайте бутона min, за да прехвърлите опциите на екрана (5, 10, 15, 20, 25, 30, 35, 40, 45, 50 и 55).
11. Използвайте бутона h, за да прехвърлите опциите на екрана (1 и 2).
12. За да отмените 2-часовата настройка, отново натиснете бутона h, докато времето, показано на екрана мига.
 - Ако не извършвате никакви действия в продължение на 2 минути, уредът ще се прехвърли в режим на готовност.
13. Когато сте задали времето, натиснете .
14. Екранът започва отброяване.
15. В края на времето за готвене уредът преминава в режим "поддържане на топло".
16. Лампичката  ще светне.
17. Препоръчваме да отстраните храната веднага щом се е сготвила, за да не се стигне до навлажняване.
18. Натиснете бутон . Отворете капака. Извадете храната.

ПОДДЪРЖА ТОПЛО

- Ако желаете да използвате функцията, която поддържа топло след дадена неотговаряща на нея програма, тогава, когато на екрана остане само мигащата лампичка , натиснете .
- Натиснете  за излизане от функцията.

ТАЙМЕРЪТ

- Можете да използвате таймера за отлагане с програмите за супа , кисело мляко , хляб , пара  и овесена каша .
- Направете това непосредствено след задаване на времето за готвене и преди да натиснете старт :
 1. Натиснете бутон . Лампичката  ще светне.
 2. Изберете кога желаете да е готова храната.
 3. Например ако в момента часът е 14:00 и желаете да е готово в 21:00, е необходимо да зададете времето на 7 часа.
 4. Използвайте бутоните за час и минута (**h** и **min**), за да настроите точно часът и минутите.
 5. Натиснете бутон .

ГРИЖИ И ПОДДРЪЖКА







1. Изключете уреда от контакта и го оставете да изстине.
2. Извадете щепсела от контакта, след това извадете конектора от входа за електричество на уреда.
3. Когато капакът е затворен, хванете горната част на филтъра и го натиснете, за да го изкарате от капака. (ФИГ. А).
4. Обърнете го, за да се виждат маркировките върху предния край. (ФИГ. В).
5. Хванете капака на филтъра здраво и обърнете останалата част от филтъра към отворения катинар . (ФИГ. С).
6. Натиснете разделите в дъното на вътрешния капак и го издърпайте от уреда.
7. Измийте сменяемите части.
8. Почистете всички повърхности с чиста влажна кърпа.
9. Не поставяйте която и да е част от уреда в миялна машина.
10. Сглобете филтъра отново и го поставете в самия капак.
11. Поставете вътрешния във външния капак.









РЕЦИКЛИРАНЕ



За да се избегнат екологични и здравни проблеми поради наличие на опасни субстанции, уредите, акумулаторните и неакумулаторните батерии, обозначени с един от тези символи, не трябва да се изхвърлят заедно с несортирани общински отпадъци. Винаги изхвърляйте електрически и електронни продукти и, където е приложимо, акумулаторни и неакумулаторни батерии, на подходящо официално място за рециклиране/събиране.

РЕЦЕПТИ

-  супена лъжица (15 мл)
-  чаена лъжичка (5 мл)
- g** грамове
- ml** милилитри
-  мерителна чаша
-  стрък (целина)
-  шепа
-  яйце, средно голямо (53-63 гр)

-  щипка
-  връзка
-  клонче
-  скилидка(и)
-  консерва
-  буркан
-  малко пакетче (7g)
-  яйце, голямо (63-73 гр)

ЧИЛИ СЪС ЗЕЛЕНЧУЦИ И КУС-КУС

БАВНО ГОТВЕНЕ 🍲

- 1 глава червен лук, нарязана
- 1 голяма глава лук, нарязана
- 2 🍷 скилидки чесън, обелени и нарязани
- 120-140 ml кус-кус
- 1 🍲 червен боб
- 1 🍷 смлян кориандър
- 1 🍷 доматино пюре
- 850 ml зеленчуков бульон
- 2 🍷 горещ доматиен сок
- 1 червена чушка, с премахнати семена и нарязана
- 1 жълта чушка, с премахнати семена и нарязана
- 1 оранжева чушка, с премахнати семена и нарязана

- 1 🍷 зехтин
- 1 🍲 боб сорт Лимата
- 1 🍲 боб канелини
- 1 🍲 зелена чушка халапеньо
- 1 🍲 накълцани домати
- 2 🍷 смлян кимион
- 1 🍷 захар
- 2 🍷 чили на прах
- 2 🍷 сух риган

за сервиране:

- настъргано сирене
- майка връзка кориандър, нарязан
- заквасена сметана

Отворете капака. Добавете олиото. Изберете 🍷 в менюто и натиснете ⬇️. Добавете лука и чесъна. Гответе до омекване на лука. Отцедете боба и го добавете. Оставете кус-куса настрана. Добавете останалите съставки. Натиснете ⬇️ два пъти, за да спрете програмата. Затворете капака. Изберете 🍷. Добавете кус-куса 30 минути преди края на готвенето. Ако готвенето вече е приключило, изберете 🍷 от менюто и гответе още около 20 минути. Сервирайте в купа с шепя сирене, малко заквасена сметана и поръсен свеж кориандър. За класическо вегетарианско чили, пропуснете кус-куса.

ДОМАШНО КИСЕЛО МЛЯКО

КИСЕЛО МЛЯКО 🍲

1200 ml мляко

100 ml кисело мляко

вариант с вкус на плодове

50 g замразени смесени горски плодове

1 🍷 мед

Отворете капака. Добавете пряното мляко. Изберете 🍷 в менюто и натиснете ⬇️. Оставете млякото да се затопли, докато по краищата започнат да се появяват балончета. Натиснете ⬇️ два пъти, за да спрете програмата. Оставете млякото да се охлади между 37°C и 45°C. Разбъркайте киселото мляко в пряното мляко. Те трябва да са изцяло смесени, в противен случай млякото ще стане на бучки. Затворете капака. Изберете 🍲 в менюто и натиснете ⬇️. Изчакайте докато програмата приключи. Оставете киселото мляко в хладилника до пълно охлаждане. Загрейте леко горските плодове в тиган. Добавете меда. Когато горските плодове започнат да се разпадат, отстранете от котлона, оставете да се охладят и след това ги смесете с киселото мляко. Ако желаете да съхранявате Вашето кисело мляко, трябва да стерилизирате бурканите, които ще използвате. Загрейте ги във фурна до 100°C за 10 минути. Киселото мляко ще се запази до 2 седмици при съхранение в хладилник.

ГОРЕЩО НЮЙОРКСКО ЧИЛИ С ГОВЕЖДО МЕСО

ЗАДУШАВАНЕ 🍲









- 450 g говеждо за готвене
- 3 🍷 скилидки чесън, обелени и нарязани
- 2 🍷 смлян кимион
- 1 🍷 много лют червен пипер
- 1 🍷 пушен (лют) червен пипер
- 1 зелена чушка
- 1 🍷 сол
- 1 🍷 листа босилек, нарязани на едро



- 1 🍷 зехтин
- 2 глави лук, нарязани
- 2 🍷 чили на прах
- 2 🍷 доматиен сок
- 2 🍲 домати
- 1 🍷 дафинов лист
- 1 🍷 черен пипер
- 1 🍲 червен боб

Отворете капака. Добавете олиото. Изберете 🍷 в менюто и натиснете ⬇️. Нарезете говеждото, доматиите и чушките на хапки. Задушете месото до покафеняване и след това отстранете. Добавете лука, чесъна и всички подправки. Гответе до омекване на лука. Прибавете месото. Оставете боба настрана. Добавете останалите съставки. Натиснете ⬇️ два пъти, за да спрете програмата. Затворете капака. Изберете 🍷. Добавете боба 30 минути преди края на готвенето. Ако месото все още е леко жилаво в края на програмата, добавете чаша вода и пуснете програмата за месо за още 30 минути

МАРОКАНСКИ ТАЖИН С РИБА

РИБА

2 	скилидки чесън, обелени и нарязани	1	глава лук, нарязана
2 	стъбло целина, нарязано	2	накълцани домати
1 	смян кимион	1 	смян джиджифил
1 	куркума	1	пръчка канела
120 ml	бяло вино	1 	доматено пюре
120 ml	рибен бульон	1	лимон
675 g	риба (треска/пикша/сьомга)	1 	зелени маслини
1	малка връзка кориандър, нарязан	1 	паста Хариса
1	червена чушка, с премахнати семена и нарязана		
	сол и пипер		







Оставете кориандъра настрана. Отворете капака. Добавете останалите съставки. Затворете капака. Изберете  в менюто и натиснете . Гответе, докато рибата започне да се разпада (40-50 минути). Натиснете  два пъти, за да спрете програмата. Добавете корандъра. Овкусете с подправките и сервирайте.

Това ястие е чудесно с кус-кус.







ИРЛАНДСКО ЗАДУШЕНО С КНЕДЛИ С КОЗЕ СИРЕНЕ

ЗАДУШАВАНЕ





за задушено:

1.8 kg	агнешка плешка (сготвена)	1 	зехтин
250 g	бекон на лентички	3 	чесън (счукан)
950 ml	агнешки бульон		сол и пипер
1	голяма глава лук, нарязана	2	моркова, нарязани
2 	стъбло целина, нарязано	2 	розмарин, накълцан
2 	доматено пюре	1 	царевично брашно

за кнедлите:

100 g	самонабухващо брашно	1 	бакпулвер
50 g	лой	1 	сол
75 ml	вода	1 	сушен магданоз
40 g	козе сирене (меко)	1 	сушена мащерка
1 	сушен риган	1 	черен пипер

за задушено:

Обезкостете месото. Нарезжете месото и бекона на хапки. Отворете капака. Изберете  в менюто и натиснете . Добавете продуктите. Сложете да ври, като разбърквате. Сложете на слаб огън за 10 минути. Прехвърлете бульона в кана. Добавете олиото. Добавете лука и го запържете до омекване. Добавете месото, чесъна, подправките и останалите зеленчуци и гответе в продължение на 5 минути. Добавете продуктите. Добавете доматеното пюре. Натиснете  два пъти, за да спрете програмата. Затворете капака. Изберете .

за кнедлите:

Сместете всички съставки на ръка. Разделете сместа на 6 топки. Оставете го да почине за 20 минути.



за завършек:



Направете гладка паста от царевичното брашно и малко вода в чаша. 30 минути преди края на готвенето отворете капака. Разбъркайте пастата в задушено. Добавете кнедлите. Затворете капака. Изчакайте до края на програмата и след това сервирайте. Една чудесна купа с добра храна!

- Ако не разполагате със сготвено агнешко, можете да използвате сурово, с програмата за бавно готвене вместо програмата за задушено, като след това продължите от момента с кнедлите.

ЯСТИЕ В ЕДИН СЪД С ПЕРЛЕН ЕЧЕМИК И БОБ БОРЛОТИ





ЗАДУШАВАНЕ

- 1  зехтин
- 175 g перлен ечемик
- 1  накълцани домати
- 1000 ml зеленчуков бульон
- 125 ml сухо червено вино

- 1  боб борлоти
- 1 глава лук, нарязана на дребно
- 1  доматино пюре
- 2  магданоз (накълцан)
- сол и пипер



за сервиране:



растително масло с чили (по желание)





Отворете капака. Изберете  в менюто и натиснете . Добавете продуктите. Сложете да ври, като разбърквате. Сложете на слаб огън за 10 минути. Прехвърлете бульона в кана. Добавете олиото. Добавете лука и го запържете до омекване. Добавете виното и гответе няколко минути. Добавете перления ечемик и разбъркайте, докато започне да поема цвета на виното. Отцедете боба и го добавете. Добавете доматиите. Добавете продуктите. Натиснете  два пъти, за да спрете програмата. Затворете капака. Изберете  30 минути преди края на готвенето отворете капака. Проверете количеството течност в купата. Добавете 150 мл гореща вода, ако е необходимо. Затворете капака. Изчакайте докато програмата приключи. Сервирайте с пресен хрупкав хляб и няколко капки горещо растително масло с чили.

СУПА ОТ СУШЕН ГРАХ И СВИНСКИ ДЖОЛАН

БАВНО ГОТВЕНЕ



- 1150 ml пилешки бульон
- 225 g сушен грах
- 1  стъбло целина, нарязано
- 1  мащерка, нарязана на дребно
- 1 свински джолан



- 1 глава лук, нарязана на дребно
- 1 морков, нарязан
- 2  чесън (счукан)
- 1  дафинов лист
- черен пипер



Отворете капака. Добавете продуктите. Изберете  в менюто и натиснете . Сложете да ври, като разбърквате. Сложете на слаб огън за 10 минути. Добавете останалите съставки. Натиснете  два пъти, за да спрете програмата. Затворете капака. Изберете . Изчакайте докато програмата приключи. Оставете свинския джолан настрана. Отстранете кожата и кокалите. Нарезжете месото на кубчета. Извадете дафиновия лист. Намачкайте сушения грах с opakото на дървена лъжица. Прибавете месото. Овкусетe с подправките и сервирайте. Истински рай в купичка!

СЪОМГА С АРОМАТНА КОРИЧКА

РИБА

- 2 филета съомга (с кожата)
- 1  червен пипер
- 1/2  смлян кимион
- 1  светло кафява захар



- 1  зехтин
- 1  чили на прах
- 1  сол и пипер
- 1 лимон

Смесете червения пипер, лютия червен пипер, кимиона, захарта, солта и черния пипер. Поръсете върху филетата от съомга. Отворете капака. Добавете олиото. Изберете  в менюто и натиснете . Изчакайте няколко минути, докато олиото загрее. Добавете филетата с кожата надолу. Затворете капака. Това е чудесна комбинация от задушаване и пържене на парчетата риба, като накрая се получава хрупкава кожа. Сервирайте с резен лимон. Едно чудесно леко ястие.

ШОКОЛАДОВО БРАУНИ



ТОРТА 

170 g	безсолно масло
340 g	захар
170 g	какао на прах
110 g	капки млечен шоколад

3	 70
1	 ванилова есенция
1	 сол
75 g	обикновено брашно



за сервиране:



ванилов сладолед (по желание)



Разтопете чистото масло в тенджерата на слаб огън. Поставете фолио, намазано с масло, от вътрешната страна на купата. Разбийте разтопеното масло, захар, какао на прах, брашно, яйца, ванилия и сол в подходящ съд. Добавете шоколадовите капки. Поставете тестото във фолиото в купата. Затворете капака. Изберете  от менюто. Настройте времето за готвене на 1 час и 30 минути. Натиснете бутон . Браунито ще бъде твърдо по краищата и леко течено в центъра. Сервирайте топло със сладолед отгоре.

ГОЛЯМА ДОМАТЕНА СУПА

СУПА 



1	глава лук, нарязана
1 	накълцани домати
550 ml	пилешки бульон
1 	доматено пюре
1 	черен пипер
1	червена чушка, с премахнати семена и нарязана

1 	зехтин
2	накълцани домати
2	картофи
1 	сушени смесени подправки

Отворете капака. Добавете продуктите. Изберете  в менюто и натиснете . Сложете да ври, като разбърквате. Сложете на слаб огън за 10 минути. Прехвърлете бульона в кана. Натиснете  два пъти, за да спрете програмата. Обелете и нарежете домати в кубчета. Изберете  в менюто и натиснете . Добавете олиото. Добавете лука и сладкия пипер. Гответе до омекване на лука. Добавете продуктите. Добавете останалите съставки. Затворете капака. Изчакайте докато програмата приключи. Овкусете. Сервирайте с хрупкав хляб.



РИЗОТО С ЧЕРВЕНО ЦВЕКЛО В МУЛТИФУНКЦИОНАЛЕН УРЕД ЗА ГОТВЕНЕ





ОВЕСЕНА КАША/РИЗОТО 

900 ml	зеленчуков бульон / пилешки бульон
2 	скилидки чесън, обелени и нарязани
250 ml	бяло вино
1 	мащерка, нарязана на дребно

400 g	червено цвекло
1	глава лук, нарязана на дребно
250 g	ориз арборио / ориз за ризото
2 	зехтин

за завършек:

100 ml	кисело мляко
1 	магданоз (накълцан)
1 	чисто масло



Отворете капака. Изберете  в менюто и натиснете . Добавете продуктите. Сложете да ври, като разбърквате. Сложете на слаб огън за 10 минути. Прехвърлете бульона в кана. Натиснете  два пъти, за да спрете програмата. Изберете  в менюто и натиснете . Оставете да се затопли. Обелете цвеклото и го нарежете на кубчета от 1 см. Поставете цвеклото, чесъна и лука в купата. Гответе до омекване на лука. Добавете и разбъркайте ориза. Затворете капака и гответе 3-4 минути. Отворете капака. Добавете и разбъркайте виното. Затворете капака и гответе 3-4 минути. Отворете капака. Добавете мащерката. Добавете продуктите. Затворете капака. Изчакайте докато програмата приключи. Проверете ориза – трябва да бъде леко твърд, но не прекалено. Ако не е съвсем готов, добавете малко вода и гответе още няколко минути. Добавете и разбъркайте маслото – това придава блясък на ризотото. Сервирайте с лъжица кисело мляко и поръсете с магданоз. Това ястие е много подходящо за предястие или за лек обяд.







БЯЛ ХЛЯБ

ХЛЯБ



1  златен сироп
320 ml мляко
500 g бяло брашно за хляб



1  чисто масло
1  суха мая
1  сол





Отворете капака. Добавете пряното мляко. Изберете  в менюто и натиснете . Оставете млякото да се затопли, докато по краищата започнат да се появяват балончета. Прехвърлете млякото в кана. Натиснете  два пъти, за да спрете програмата. Оставете млякото да се охлади между 37°C и 45°C. Разтопете чистото масло в тенджерата на слаб огън. Смесете брашното и солта в купа. Добавете маята, маслото и сиропа. Добавете пряното мляко и замесете на топка. Ако сместа е много лепкава, добавете още малко брашно. Покрийте тестото и оставете на топло за 10 минути. Замесете го отново. Покрийте тестото и оставете на топло за 10 минути. Отворете капака. Изберете  в менюто и натиснете . Затворете капака. 30 минути преди края на готвенето отворете капака. Обърнете хляба. Това ще придаде малко цвят и хрупкавост на горната част на хляба. Изчакайте докато програмата приключи. Сервирайте с парченца масло.

СУПА ОТ ЧОРИЗО, ЗЕЛЕ И ЯБЪЛКИ

СУПА

¼ наденица чоризо, нарязана на дребно
1 ябълка
2  стъбло целина, нарязано
¼ глава зеле, нарязано на дребно
2  скилидки чесън, обелени и нарязани
1  сол
850 ml зеленчуков бульон

1 глава лук, нарязана на дребно
2 моркова, нарязани
2 напълцани домати
1  доматено пюре
1  много лют червен пипер
1  черен пипер



Отворете капака. Изберете  в менюто и натиснете . Сотирайте чоризото за 2 минути. Добавете лука и чесъна. Гответе до омекване на лука. Обелете, почистете и нарежете ябълката. Добавете останалите съставки. Натиснете  два пъти, за да спрете програмата. Затворете капака. Изберете  в менюто и натиснете . Изчакайте докато програмата приключи. Това е една чудесна супа, а ако я оставите за една нощ в хладилника, вкусът • ще се развие допълнително.

ЗАДУШЕН АРТИШОК

ПАРА

1  скилидки чесън, обелени и нарязани
клонки подправки (пелин, мента, магданоз, мащерка)





2 глави артишок
1 лимон



Нарежете лимона. Изрежете стъблото в основата на всяка глава артишок. Изрежете горната една четвърт от всяка глава артишок. Изхвърлете всички наранени листа. Натрийте изрязаните повърхности с резен лимон. Поставете резените лимони в кошницата. Добавете клонките подправки. Добавете чесъна. Поставете артишока отгоре. Налейте вода до ниво 2 от скалата в ляво, втърете в купата. Поставете кошницата върху купата. Затворете капака. Изберете  в менюто и натиснете . Артишокът е сготвен, когато външните листа могат да се премахнат лесно. Сервирайте топъл или студен със сос винегрет. Невероятно!

СИРОПИРАН ПАНДИШАНОВ ПУДИНГ

ПАРА

115 g чисто масло
100 g пудра захар
175 g самонабухващо брашно
4  златен сироп

2   ванилова есенция
¼  мляко
2  мляко



Разбийте яйцата в отделна купа. Разбийте размекнатото масло и захар в купа. Постепенно добавете яйцата, ванилията, а след това и брашното. Добавете и разбъркайте пряното мляко. Намаслете термоустойчива 1200 ml купа. Поставете сиропа на дъното на термоустойчивата купа и сложете сместа отгоре. Покрийте с хартия за печене, а след това с фолио и завържете горната част с връв. Отворете капака. Поставете термоустойчивата купа в купата на уреда. Добавете достатъчно вряла вода в купата на уреда, така че да достигне до 3 см под ръба на термоустойчивата купа. Затворете капака. Изберете  от менюто. Настройте времето за готвене на 1 час и 30 минути. Натиснете бутон . Изчакайте докато програмата приключи. Обърнете в чиния и сервирайте сладкиша топъл. Това е един чудесен пудинг по всяко време на годината!

СОДЕН ХЛЯБ

ХЛЯБ



1  смес за соден хляб
350 ml вода

чисто масло

Отворете капака. Намажете купата с масло. Изберете  от менюто. Затворете капака. Настройте времето за готвене на 2 часа и 15 минути. Натиснете бутон . Оставете да се затопли. Поставете сместа за соден хляб в купата. Добавете водата. Омесете на ръка до получаване на топка. Отворете капака. Поставете тестото в купата. Разделете тестото на четири части с пластмасова шпатула. Затворете капака. 30 минути преди края на готвенето отворете капака. Обърнете хляба. Това ще придаде малко цвят и хрупкавост на горната част на хляба. Изчакайте докато програмата приключи. Оставете да изстине върху метална решетка. Сервирайте хляба самостоятелно със солено масло или с друго ястие.

PORRIDGE (ОВЕСЕНА КАША)

ОВЕСЕНА КАША/РИЗОТО



2  овесена каша
1/4  сол

2  вода
захар

за сервиране:



тъмно кафява захар

мляко / нискомаслена сметана

Отворете капака. Добавете овесените ядки, солта и захарта. Налейте вода до ниво 1 1/2 от скалата в дясно, вътре в купата. Затворете капака. Изберете  в менюто и натиснете . Изчакайте докато програмата приключи. Сервирайте с прясно мляко или сметана. Поръсете с тъмна кафява захар. Ако желаете, можете да добавите нарязани сушени кайсии или разполовени сушени сливи (без костилките) 15 минути преди края на времето за готвене. Останалата porridge (овесена каша) може да се съхранява в хладилник до 2 дни и след това да се претопли.

PORRIDGE (ОВЕСЕНА КАША) С ЯДКИ

ОВЕСЕНА КАША/РИЗОТО



1/2  овесени ядки
120 ml мляко
1  смляна канела

3  вода
кокосови стърготини

за сервиране:



златен сироп

натрошени бадеми

Отворете капака. Добавете овесените ядки, канела, кокосови стърготини и прясно мляко. Налейте вода до ниво 1/2 от скалата в дясно, вътре в купата. Затворете капака. Изберете  в менюто и натиснете . Изчакайте докато програмата приключи. Поръсете със златен сироп и натрошени бадеми отгоре.

ПИКАНТЕН ОРИЗ

ОРИЗ







2  ориз
1 кубче бульон (зеленчуков)
2  стъбло целина, нарязано
1  грах (по желание)
1 червена чушка, с премахнати семена и нарязана



2 вода
моркова, нарязани
1  куркума

Отворете капака. Поставете ориза в купата. Налейте вода до ниво 2 от скалата в ляво, вътре в купата. Натрошете кубчето бульон и го добавете и разбъркайте във водата. Добавете останалите съставки. Затворете капака. Изберете . Изчакайте до края на програмата и след това сервирайте. Ако оризът не е съвсем готов, оставете го за няколко минути със затворен капак, за да се задуши.

ПИЛЕ С ДОМАТИ И ГЪБИ



МЕСО 



2	пилешки гърди, без кожа и обезкостени	1 	зехтин
450 g	кралски печурки	1 	накълцани домати
2 	скилидки чесън, обелени и нарязани	1 	доматен сок
1 	сос Урчестършир сол и пипер	1 	сух риган

Отворете капака. Изберете  в менюто и натиснете . Добавете олиото. Овкусет пилешките гърди със сол и пипер и ги поставете в купата. Обърнете месото, така че да се запечата от двете страни. Добавете чесъна и гъбите. Гответе 3-4 минути, като обърнете пилешкото месо веднъж. Добавете домати, сос Урчестър, доматения сос и ригана. Продължете да готвите, като обърнете пилешкото месо още веднъж. Проверете дали пилешкото месо е добре сготвено. Сервирайте с паста, картофи или ориз. Едно бързо и вкусно ястие с продукти, които имате в наличност.

РЕБРА, ЗАДУШЕНИ В СТАУТ, С КЛЕНОВ СИРОП И СОЕВ СОС









МЕСО 





1 kg	свински ребра	1	глава лук, нарязана
350 ml	Гинес / стаут	1 	зехтин
140 ml	говежди / свински бульон	2 	тъпен соев сос
3 	скилидки чесън, обелени и нарязани	60 ml	кленов сируп / мед

Отворете капака. Изберете  от менюто. Добавете олиото. Настройте времето за готвене на 1 час и 45 минути. Натиснете бутон . Добавете ребрата и задушете за 5 минути, като обръщате от време на време. Отстранете ребрата. Добавете лука и чесъна. Гответе до омекване на лука. Върнете ребрата в купата. Добавете и разбъркайте Гинеса, бульона, кленовия сируп и соевия сос Затворете капака. Изчакайте докато програмата приключи. Овкусет с подправките и сервирайте. Едно чудесно предястие или част от обяд с различни ястия.

ЯСТИЕ С ТЕЛЕШКИ ГЪРДИ В ЕДИН СЪД

БАВНО ГОТВЕНЕ 

1 kg	телешки гърди	2 	доматено пюре
2 	скилидки чесън, обелени и нарязани	2 	дафинов лист
50 g	наденица chorizo, нарязана на резени	2	моркови
2	глави червен лук, нарязани	3 	целина
600 ml	говежди бульон	2 	розмарин, накълцан
2 	сушени смесени подправки	1 	накълцани домати
6-8	картофи (малки)		сол и пипер
2 	сос Урчестършир		

Оставете картофите с кожата. Нарезете картофите, морковите и целината на големи парчета. Овкусет телешките гърди със сол и пипер. Отворете капака. Изберете  в менюто и натиснете . Добавете продуктите. Сложете да ври, като разбърквате. Сложете на слаб огън за 10 минути. Прехвърлете бульона в кана. Сотирайте chorizoto за 2 минути. Прибавете месото. Задушете ги до покафеняване от всички страни. Добавете лука, чесъна, картофите, целината и морковите. Ако разполагате с други кореноплодни, които трябва да се използват, можете да добавите и тях. Гответе до омекване на лука. Добавете продуктите. Добавете останалите съставки. Натиснете  два пъти, за да спрете програмата. Изберете . Изчакайте до края на програмата и след това сервирайте. Може да се готви 8 часа, но вероятно ястието ще бъде готово за консумация след 5 часа.

اقرأ التعليمات واحفظها في مكان آمن. في حالة اهداء الجهاز لشخص آخر ارفق معه التعليمات. يجب ازالة جميع الأغلفة قبل الاستعمال.
إجراءات أمان ضرورية

يجب اتخاذ إجراءات الأمان الأساسية التالية:

يمكن استخدام هذا الجهاز بواسطة الأطفال الذين تتراوح أعمارهم من 8 سنوات فما فوق والأشخاص ذوي القدرات الجسمانية أو الحسية أو العقلية المنخفضة أو عديمي الخبرة والمعرفة إذا تم الإشراف عليهم/تعليمهم ويفهمون المخاطر المعنية.
يجب ألا يعيب الأطفال بالجهاز.

يجب عدم قيام الأطفال بالتنظيف والصيانة إلا إذا كانوا أكبر من 8 سنوات مع الإشراف عليهم. اجعل الجهاز والكبلات بعيدا عن متناول الأطفال دون سن 8 سنوات.
إذا كان الموصل أو الكبل تالفا، يجب استبدالهما بجمع خاص متوفر من الشركة المصنعة أو وكيل خدماتها.

⚠ لا تستخدم هذا الجهاز بالقرب من أحواض الاستحمام أو الحمامات أو أي أحواض أخرى تحتوي على ماء

⚠ يمكن أن يسبب إساءة استخدام الجهاز إصابات.

⚠ سوف تصبح أسطح الجهاز ساخنة. سوف تبقى الحرارة المتبقية الأسطح ساخنة بعد الاستخدام.

- لا تضع اللحوم المجمدة أو الدواجن في الجهاز - قم بتذويبها تماما قبل الاستخدام.
- قم بطبخ اللحم والدجاج ومشتقاتهم (المفروم، البرغر، وغيرها) حتى جفاف العصارة. قم بطبخ الأسماك حتى يصبح لحمها غير نافذ.
- لا تحاول طهي أي شيء في جسم جهاز الطبخ - اطيخ فقط في وعاء قابل للنقل.
- لا تملأ فوق علامة max.
- لا تغطي الجهاز أو تضع أي شيء فوقه.
- افصل الجهاز عن التيار عند عدم الاستعمال.
- لا تستخدم أي أداة غير التي تكون مع الجهاز.
- لا تستخدم الجهاز لأغراض غير مقرر في التعليمات.
- لا تستخدم الجهاز إذا كان تالفا أو لا يعمل بصورة صحيحة.

للاستعمال المنزلي فقط

الرسومات

1. لوحة التحكم
2. الغطاء
3. قفل الغطاء
4. الغطاء الداخلي
5. كوب قياس
6. سلة
7. وعاء
8. موصل



التحضي

1. ضع الجهاز على سطح ثابت ومستوي ومقاوم للحرارة.
2. فلا تضع الجهاز بالقرب من الستائر أو تحت الأرفف أو الخزائن أو بالقرب من أي شيء يمكن أن يتعرض للتلف من جراء خروج البخار.
3. استخدم قفازات جهاز الطبخ (أو قطعة قماش) للتناول وحصدرة مقاومة للحرارة أو لوحة عشاء لوضع الوعاء بعد الطبخ.
4. ضع الوعاء داخل جهاز الطبخ.
5. أدر الوعاء ربع لفة في كل اتجاه لضمان تلامس أسفل الوعاء جيدا مع العنصر.

الأرز

1. استخدم كوب القياس لوضع الحبوب (الأرز والشوفان، الخ) في الوعاء.
2. لا تستخدم أكثر من 10 أكواب من الحبوب.
3. يتم التعليم على المقياس الموجود على اليسار داخل الوعاء من 2 إلى 10.





4. قم بملء الوعاء بالماء إلى الرقم المناظر لعدد أكواب الأرز المستخدمة.
5. اغلق الغطاء.
6. اضغط على الزر . سوف يضىء الزر.
7. سوف تومض الأقسام الخارجية للشاشة أثناء تسخين الطعام.
8. وستعرض الشاشة عندئذ مدة الطهي المتبقية (13 دقيقة) وتقوم بالعد التنازلي.
9. سيدخل الجهاز في وضع "التدفئة" (keep warm) في نهاية مدة الطهي.
10. سوف تضىء اللمبة W.
11. افتح الغطاء.
12. ارفع الوعاء وضعه على حصىرة مقاومة للحرارة أو لوحة عشاء.
13. اضغط على الزر .
14. استخدم ملعقة لتقليب واخلط الأرز للسماح بخروج جميع بخار.
15. في بعض الأحيان تكون طبقة الأرز الملامسة للوعاء قشرة.
16. وإذا كنت لا تريد، يمكنك إزالتها بالملعقة بعد تقديم الأرز.

الطهي البطيء



1. اللحم الغامق والخضروات.
- انظر "غامق/مقلي/طري/مغلي"
2. قم بغلي سائل الطهي.
- انظر "غامق/مقلي/طري/مغلي"
3. ضع المكونات الصلبة في الوعاء ثم أضف سائل الطهي.
4. اغلق الغطاء.
5. اضغط على الزر أ. سوف يضىء الزر.
6. سوف يظهر على الشاشة 8 ساعات وتقوم بالعد التنازلي.
7. سيدخل الجهاز في وضع "التدفئة" (keep warm) في نهاية مدة الطهي.
8. سوف تضىء اللمبة .
9. افتح الغطاء.
10. أخرج الطعام.
11. اضغط على الزر .

الطهي على نار هادئة





1. اللحم الغامق والخضروات.
- انظر "غامق/مقلي/طري/مغلي"
2. قم بغلي سائل الطهي.
- انظر "غامق/مقلي/طري/مغلي"
3. ضع المكونات الصلبة في الوعاء ثم أضف سائل الطهي.
4. اغلق الغطاء.
5. اضغط على الزر ز. سوف يضىء الزر.
6. سوف يظهر على الشاشة 1 ساعة وتقوم بالعد التنازلي.
7. سيدخل الجهاز في وضع "التدفئة" (keep warm) في نهاية مدة الطهي.
8. سوف تضىء اللمبة .
9. افتح الغطاء.
10. أخرج الطعام.
11. اضغط على الزر .

اللحم

1. قم بحك جميع أنحاء الطعام بزيت الطهي.
2. قم بحك أي توابل على سطح الطعام.
3. ضع ملعقة كبيرة من زيت الطهي في الوعاء.
4. ضع الطعام في الوعاء.
5. اغلق الغطاء.
6. يتوقف الوقت على حجم الطعام.
7. لا تقم بطهي أكثر من حوالي 500 غرام من الطعام في المرة الواحدة.
8. تقترح مدد طهي 10 دقائق + 10 دقائق لكل 100 غرام من وزن لحوم البقر.
9. لا تقم بطهي لحم الخنزير أو الدواجن لمدة تقل عن 30 دقيقة.
10. استخدم الزر  لاختيار في القائمة.

11. اختر مدة الطهي.
12. المدة الافتراضية 20 دقيقة.
13. يمكنك استخدام أزرار h (ساعة) و min (دقيقة) فقط أثناء وميض وقت الشاشة.
14. استخدم الزر min (دقيقة) لتحريك الشاشة خلال الخيارات (10 و 15 و 20 و 25 و 30 و 35 و 40 و 45 و 50 و 55).
15. إذا كنت تريد الطهي لمدة 1 ساعة، اضغط الزر h (ساعة).
16. للترجع عن الإعداد 1 ساعة، اضغط الزر h (ساعة) مرة أخرى أثناء وميض وقت الشاشة.
- إذا كنت لا تفعل شيئاً لمدة دقيقتين، سيعرج الجهاز إلى وضع الاستعداد.
17. عند ضبط الوقت، اضغط .
18. ستقوم الشاشة بالعد التنازلي.
19. سيدخل الجهاز في وضع "التدفئة" (keep warm) في نهاية مدة الطهي.
20. سوف تضئ المبة .
21. افتح الغطاء.
22. أخرج الطعام.
23. اضغط على الزر .

الحساء

1. اللحم الغامق والخضروات.
- انظر "غامق/مقلي/طري/مغلي"
2. ضع المكونات الصلبة في الوعاء ثم أضف سائل الطهي.
3. اغلق الغطاء.
4. استخدم الزر لاختيار  في القائمة.
5. اختر مدة الطهي.
6. المدة الافتراضية 1 ساعة.
7. يمكنك استخدام أزرار h (ساعة) و min (دقيقة) فقط أثناء وميض وقت الشاشة.
8. استخدم الزر min (دقيقة) لتحريك الشاشة خلال الخيارات (10 و 15 و 20 و 25 و 30 و 35 و 40 و 45 و 50 و 55).
9. استخدم الزر h (ساعة) لتحريك الشاشة خلال الخيارات (1 و 2 و 3 و 4 و 5).
10. للترجع عن الإعداد 5 ساعة، اضغط الزر h (ساعة) مرة أخرى أثناء وميض وقت الشاشة.
- إذا كنت لا تفعل شيئاً لمدة دقيقتين، سيعرج الجهاز إلى وضع الاستعداد.
11. لديك خيار استخدام جهاز التوقيت مع هذا البرنامج (انظر جهاز التوقيت).
12. اضغط على الزر .
13. ستقوم الشاشة بالعد التنازلي.
14. سيدخل الجهاز في وضع "التدفئة" (keep warm) في نهاية مدة الطهي.
15. سوف تضئ المبة .
16. افتح الغطاء.
17. أخرج الطعام.
18. اضغط على الزر .

الزبادي

خميرة الزبادي

- يمكنك استخدام 30 مللي لتر (2 ملعقة طعام) من:
- زبادي حي بدون نكهة - يجب أن يكون طازجا (انظر تاريخ انتهاء الصلاحية).
- سوف تعطي الماركات المختلفة نتائج مختلفة.
- الزبادي الذي صنعتته سابقا.
- تضعف البكتيريا بمرور الوقت ولا يمكنك القيام بذلك إلا 10 مرات قبل استخدام خميرة جديدة أخرى.
- قم بتجميد خميرة الزبادي المجففة المأخوذة من الصيدلية أو متجر الأغذية الصحية
- إذا كانت التعليمات الموجودة على عبوة الخميرة تختلف عن هذا الدليل، اتبع التعليمات الموجودة على العبوة.
- سوف تحتاج 1 لتر لبن.
- اللبن كامل الدسم يجعل الزبادي أكثر سماكا من اللبن قليل الدسم.
- لجعله أكثر سماكا، يمكنك إضافة ما يصل إلى 8 ملاعق كبيرة من اللبن المجفف إلى اللبن السائل.
- يمكنك أيضا استخدام اللبن المجفف المعاد أو اللبن المبخر المعلب.

صنع الزبادي

1. أنت بحاجة لقتل البكتيريا في اللبن لمنعها من التنافس مع البكتيريا الموجودة في خميرة الزبادي.
2. دع خميرة الزبادي تصل إلى درجة حرارة الغرفة أثناء تسخين اللبن.
3. افتح الغطاء.





4. استخدم برنامج التبخير (غامق/مقلي/طري/مغلي) لتسخين اللبن إلى أقل بقليل من درجة الغليان.
5. دع اللبن يسخن إلى أن يبدأ في الغليان عند الحواف.
6. دع اللبن يبرد إلى ما بين 37 درجة مئوية و 45 درجة مئوية.
7. قم بتقليل خميرة الزبادي في اللبن.
8. يجب أن تكون ممتزجة تماما وإلا سيكون الزبادي متكتل.
9. اغلق الغطاء.
10. استخدم الزر ⑦ لاختيار □ في القائمة.
11. اختر مدة الطهي.
12. المدة الافتراضية 8 ساعات.
13. يمكنك استخدام أزرار h (ساعة) و min (دقيقة) فقط أثناء وميض وقت الشاشة.
14. استخدم الزر min (دقيقة) لتحريك الشاشة خلال الخيارات (10 و 15 و 20 و 25 و 30 و 35 و 40 و 45 و 50 و 55).
15. استخدم الزر h (ساعة) لتحريك الشاشة خلال الخيارات (6 و 7 و 8 و 9 و 10).
16. للتراجع عن الإعداد 10 ساعة، اضغط الزر h (ساعة) مرة أخرى أثناء وميض وقت الشاشة.
- إذا كنت لا تفعل شيئا لمدة دقيقتين، سيعود الجهاز إلى وضع الاستعداد.
17. لديك خيار استخدام جهاز التوقيت مع هذا البرنامج (انظر جهاز التوقيت).
18. اضغط على الزر ◀.
19. ستقوم الشاشة بالعد التنازلي.
20. سيدخل الجهاز في وضع الاستعداد في نهاية مدة الطهي.
21. ولن يبقى الزبادي دافئا.
22. افتح الغطاء.
23. أخرج الطعام.
24. اضغط على الزر ⑦.

الخبز



1. قم بإذابة العجين المجمد جيداً قبل الاستخدام.
2. لا تقم بطهي أكثر من حوالي 500 غرام في المرة الواحدة.
3. امسح الوعاء بزيت طهي.
4. ضع العجين في الوعاء.
5. اغلق الغطاء.
6. استخدم الزر [لاختيار n في القائمة.
7. اختر مدة الطهي.
8. المدة الافتراضية 3 ساعات.
9. يمكنك استخدام أزرار h (ساعة) و min (دقيقة) فقط أثناء وميض وقت الشاشة.
10. استخدم الزر min (دقيقة) لتحريك الشاشة خلال الخيارات (10 و 15 و 20 و 25 و 30 و 35 و 40 و 45 و 50 و 55).
11. استخدم الزر h (ساعة) لتحريك الشاشة خلال الخيارات (1 و 2 و 3 و 4 و 5 و 6).
12. للتراجع عن الإعداد 6 ساعة، اضغط الزر h (ساعة) مرة أخرى أثناء وميض وقت الشاشة.
- إذا كنت لا تفعل شيئا لمدة دقيقتين، سيعود الجهاز إلى وضع الاستعداد.
13. لديك خيار استخدام جهاز التوقيت مع هذا البرنامج (انظر جهاز التوقيت).
14. اضغط على الزر ◀.
15. ستقوم الشاشة بالعد التنازلي.
16. سيدخل الجهاز في وضع "الندفنة" (keep warm) في نهاية مدة الطهي.
17. سوف تضئ اللمبة ☀.
18. افتح الغطاء.
19. أخرج الطعام.
20. اضغط على الزر ⑦.

السمك



1. قم بحك جميع أنحاء الطعام بزيت الطهي.
2. قم بحك أي توابل على سطح الطعام.
3. ضع ملعقة كبيرة من زيت الطهي في الوعاء.
4. ضع الطعام في الوعاء.
5. اغلق الغطاء.
6. يتوقف الوقت على حجم الطعام.
7. لا تقم بطهي أكثر من حوالي 500 غرام من الطعام في المرة الواحدة.
8. تقترح مدة طهي 10 دقيقة لكل 100 غرام من الوزن.

9. استخدم الزر [لاختيار R في القائمة. اختر مدة الطهي.
10. المدة الافتراضية 20 دقيقة.
11. يمكنك استخدام أزرار h (ساعة) و min (دقيقة) فقط أثناء وميض وقت الشاشة.
12. استخدم الزر min (دقيقة) لتحريك الشاشة خلال الخيارات (10 و 15 و 20 و 25 و 30 و 35 و 40 و 45 و 50 و 55).
13. إذا كنت تريد الطهي لمدة 1 ساعة، اضغط الزر h (ساعة).
14. للتراجع عن الإعداد 1 ساعة، اضغط الزر h (ساعة) مرة أخرى أثناء وميض وقت الشاشة.
15. إذا كنت لا تفعل شيئاً لمدة دقيقتين، سيعرج الجهاز إلى وضع الاستعداد.
16. عند ضبط الوقت، اضغط .
17. ستقوم الشاشة بالعد التنازلي.
18. سيدخل الجهاز في وضع "التدفئة" (keep warm) في نهاية مدة الطهي.
- سوف تضئ اللمبة .
- من الأفضل إخراج الطعام بمجرد طهيه لمنعه من الجفاف.
- افتح الغطاء.
- أخرج الطعام.
- اضغط على الزر .

التبخير

1. قم بملء الوعاء بماء بارد إلى العلامة 6.
2. ضع السلة فوق الوعاء وضع الطعام في السلة.
3. للطبخ المنتظم، اقطع كل قطعة من الطعام بنفس الحجم تقريبا.
4. للبخار أو أي شيء يتكسر أو يسقط في الماء، قم بلفه برقائق الألمنيوم.
5. توي الحذر عند إخراج الرزمة - قم بارتداء قفازات جهاز الطبخ واستخدم ملاعق بلاستيكية بملاط.
6. اغلق الغطاء.
7. استخدم الزر  لاختيار  في القائمة.
8. اختر مدة الطهي.
9. المدة الافتراضية 30 دقيقة.
- ينبغي أن يتم الطهي في خلال المدة الافتراضية:

الكمية	الطعام (طازج)
200g	الفاصوليا الخضراء
200g	غرام كرنب بروكسيل
200g	غرام الجزر (شرايح)
400g	غرام البطاطس (أرباع)
200g	البروكلي
ربع	الملفوف
2	كيزان الذرة

10. يمكنك استخدام أزرار h (ساعة) و min (دقيقة) فقط أثناء وميض وقت الشاشة.
11. استخدم الزر min (دقيقة) لتحريك الشاشة خلال الخيارات (30 و 35 و 40 و 45 و 50 و 55).
12. استخدم الزر h (ساعة) لتحريك الشاشة خلال الخيارات (1 و 2).
13. للتراجع عن الإعداد 2 ساعة، اضغط الزر h (ساعة) مرة أخرى أثناء وميض وقت الشاشة.
14. إذا كنت لا تفعل شيئاً لمدة دقيقتين، سيعرج الجهاز إلى وضع الاستعداد.
- لديك خيار استخدام جهاز التوقيت مع هذا البرنامج (انظر جهاز التوقيت).
15. اضغط على الزر .
16. ستقوم الشاشة بالعد التنازلي.
17. سيدخل الجهاز في وضع "التدفئة" (keep warm) في نهاية مدة الطهي.
18. سوف تضئ اللمبة .
19. من الأفضل إخراج الطعام بمجرد طهيه لمنعه من التشبع بالماء.
20. افتح الغطاء.
21. أخرج الطعام.
22. اضغط على الزر .

غامق/مقلي/طري/مغلي (brown/saute/soften/boil) ٢٢

1. يمكنك استخدام برنامج التبخير S في إعدادة الافتراضي مع جعل الغطاء مفتوحاً وارتفاع درجة حرارة المقلاة لمدة 30 دقيقة قبل الطهي ببرنامج آخر.
2. استخدمه بقليل من الزيت للحم الغامق والخضروات. لقلّي وتطرية البصل والكرفس والكراث، الخ.
3. استخدمه بماء أو مرق لتسخين سوائل الطهي مسبقاً.
4. عند التبديل إلى البرنامج الرئيسي، يدفأ الجهاز وستكون بعض أو كل المكونات في الوعاء بالفعل.
5. لا حاجة عندئذ لغسل المقلاة التي استخدمتها أثناء الإعداد.

العصيدة/الريستو

استخدم كوب القياس لوضع الحبوب (الأرز والشوفان، الخ) في الوعاء.

العصيدة

- استخدم المقياس الموجود على اليمين داخل الوعاء المعلم عليه من 1/2 إلى 1 1/2.
- لا تملأ فوق علامة max.

الكونجي

- استخدم المقياس الموجود في الوسط داخل الوعاء المعلم عليه من 1 إلى 3.
- لا تملأ فوق علامة max.
- 1. قم بملء الوعاء بالماء إلى الرقم المناظر لعدد أكواب الحبوب.
- 2. أغلق الغطاء.
- 3. استخدم الزر ٧ لاختيار ٢ في القائمة.
- 4. اختر مدة الطهي.
- 5. المدة الافتراضية 1 ساعة.
- 6. يمكنك استخدام أزرار h (ساعة) و min (دقيقة) فقط أثناء وميض وقت الشاشة.
- 7. استخدم الزر min (دقيقة) لتحريك الشاشة خلال الخيارات (5 و 10 و 15 و 20 و 25 و 30 و 35 و 40 و 45 و 50 و 55).
- 8. استخدم الزر h (ساعة) لتحريك الشاشة خلال الخيارات (1 و 2 و 3 و 4).
- 9. للتراجع عن الإعداد 4 ساعة، اضغط الزر h (ساعة) مرة أخرى أثناء وميض وقت الشاشة.
- 10. إذا كنت لا تفعل شيئاً لمدة دقيقتين، سيعوج الجهاز إلى وضع الاستعداد.
- 11. لديك خيار استخدام جهاز التوقيت مع هذا البرنامج (انظر جهاز التوقيت).
- 12. اضغط على الزر ٤.
- 13. ستقوم الشاشة بالعد التنازلي.
- 14. سيدخل الجهاز في وضع "التدفئة" (keep warm) في نهاية مدة الطهي.
- 15. سوف تضئ اللمبة ١١.
- 16. افتح الغطاء.
- 17. أخرج الطعام.
- 18. اضغط على الزر ٧.

الريستو

اتبع الوصفة التي تظهر لاحقاً في هذا الكتيب.

الكيك

1. قم بإذابة العجين المجمد جيداً قبل الاستخدام.
2. لا تملأ الوعاء أكثر من نصفه تقريباً.
3. امسح الوعاء بزيت طهي.
4. ضع العجين في الوعاء.
5. اغلق الغطاء.
6. استخدم الزر [] لاختيار ٣ في القائمة.
7. اختر مدة الطهي.
8. المدة الافتراضية 40 دقيقة.
9. يمكنك استخدام أزرار h (ساعة) و min (دقيقة) فقط أثناء وميض وقت الشاشة.
10. استخدم الزر min (دقيقة) لتحريك الشاشة خلال الخيارات (30 و 35 و 40 و 45 و 50 و 55).
11. استخدم الزر h (ساعة) لتحريك الشاشة خلال الخيارات (1 و 2).
12. للتراجع عن الإعداد 2 ساعة، اضغط الزر h (ساعة) مرة أخرى أثناء وميض وقت الشاشة.
- إذا كنت لا تفعل شيئاً لمدة دقيقتين، سيعوج الجهاز إلى وضع الاستعداد.
13. عند ضبط الوقت، اضغط ٤.
14. ستقوم الشاشة بالعد التنازلي.
15. سيدخل الجهاز في وضع "التدفئة" (keep warm) في نهاية مدة الطهي.
16. سوف تضئ اللمبة ١١.

17. من الأفضل إخراج الطعام بمجرد طهيها لمنعه من التشبع بالماء.



18. افتح الغطاء.

19. أخرج الطعام.

20. اضغط على الزر (V).





التدفئة

• إذا أردت استخدام خاصية التدفئة بعد برنامج لا يدعمها ويكون الشيء الوحيد الذي يظهر على الشاشة هو الضوء الومض

، اضغط .

• اضغط  للخروج من هذه الخاصية.

⊕ جهاز التوقيت

• يمكنك استخدام جهاز توقيت التأخير مع برامج الحساء  والخبز  والبخار  والعصيدة .

• قم بذلك على الفور بعد ضبط مدة الطهي وقبل الضغط على البدء V.

1. اضغط على الزر ⊕. سوف تضئ لللمبة .

2. قرر متى تريد أن يكون الطعام جاهزاً.

3. على سبيل المثال، إذا كانت الساعة 2 الآن وتريد أن يكون الطعام جاهزاً في الساعة 9، يجب أن تضبط المدة على 7 ساعات

4. استخدم زري الساعة h والدقيقة min لضبط الساعة والدقيقة بشكل صحيح.

5. اضغط على الزر (V).

العناية والصيانة

1. افصل الجهاز عن التيار الكهربائي واتركه يبرد.

2. أخرج المقبس من مقبس الطاقة ثم أخرج الموصل من مدخل الطاقة على الجهاز

3. مع غلق الغطاء، أمسك الجزء العلوي من الفلتر وأخرجه من الغطاء. (الشكل A).

4. اقلبه لكشف العلامات التي على الحافة الأمامية.

5. أمسك غطاء الفلتر بسرعة وأدر بقية الفلتر نحو القفل المفتوح  (الشكل B).

6. اضغط على الألسنة الموجودة في الجزء السفلي من الغطاء الداخلي واسحب من الجهاز (الشكل C).

7. اغسل الأجزاء القابلة للفك.

8. قم بمسح جميع الأسطح بقطعة فماش مبللة.

9. لا تضع أي جزء من الجهاز في غسلية صحون.

10. أعد تركيب الفلتر وأعدّه إلى مكانه في الغطاء.

11. أعد الغطاء الداخلي إلى مكانه في الغطاء.

عادة التدوير

لتجنب المشاكل البيئية والصحية الناجمة عن المواد الخطرة، يجب عدم التخلص من الأجهزة، والبطاريات

القابلة لإعادة الشحن والبطاريات غير القابلة لإعادة الشحن التي تحمل علامة واحدة من هذه الرموز مع

نفايات البلدية غير المصنفة. يجب دائماً التخلص من المنتجات الكهربائية والإلكترونية، وكذلك إذا أمكن،

البطاريات القابلة لإعادة الشحن وغير القابلة لإعادة الشحن، في نقطة رسمية مناسبة لإعادة التدوير/تجميع

المخلفات.



الوصفات

ملعقة طعام (15 مللي لتر)		غرام	g
ملعقة صغيرة (5 مللي لتر)		مللي لتر	ml
حزمة		كمية ضئيلة	
غصن		فص/فصوص	
(كوب قياس) مرفق		(كيس 7) غرام	
علبة		جرة	
(عود/عرق) كرفس		(بيضة كبيرة (73-63) غرام	70
باقية		(البيض، متوسط (53 إلى 63) غرام	60

AE

جهاز الطبخ البطيء





فلفل حار مكسيكي	1	بصلة حمراء، مفرومة	1
فاصوليا رومي	1	زيت زيتون	1
فاصوليا جافة	1	بصلة كبيرة، مفرومة	1
فاصوليا بيضاء	1	ثوم، مقشر ومفروم	2
طماطم مقطعة	1	فلفل أحمر، منزوع البذور ومفروم	1
مسحوق فلفل حار	2	فلفل أصفر، منزوع البذور ومفروم	1
زعتر مجفف	2	فلفل برتقالي، منزوع البذور ومفروم	1
كمون مطحون	2	كزبرة مطحونة	1
معجون طماطم	1	صلصة طماطم حارة	2
سكر	1	مرقة خضار	850 ml
كسكسى	120-140 ml	كسكسى	120-140 ml

للتقديم:

كريمه حامضة





جبن مبشور

حفنة كزبرة صغيرة، مفرومة

افتح الغطاء. أضف الزيت. اختر  في القائمة ثم اضغط . أضف البصل والثوم. قم بطهي البصل إلى أن يلين. قم بتفريغ الفاصوليا وإضافتها. احفظ الكسكسى. أضف المكونات المتبقية. اضغط على  مرتين لوقف البرنامج. اغلق الغطاء. اختر . أضف الكسكسى قبل انتهاء الطهي بـ 30 دقيقة. إذا انتهى الطهي بالفعل، اختر  في القائمة وقم بالطهي لمدة حوالي 20 دقيقة أكثر. يقدم في وعاء قليل من الجبن ورشة من الكريمة الحامضة ورشة من الكزبرة الطازجة. للفلفل الحار النباتي الكلاسيكي استبعد الكسكسى.





الزبادي المنزلي

زبادي	100 ml	حليب	1200 ml
		توت صيفي مختلط مجمد	50 g
		عسل	1

افتح الغطاء. أضف اللبن. اختر  في القائمة ثم اضغط . دع اللبن يسخن إلى أن يبدأ في الغليان عند الحواف. اضغط على  مرتين لوقف البرنامج. دع اللبن يبرد إلى ما بين 37 درجة مئوية و 45 درجة مئوية. قلب الزبادي في اللبن. يجب أن تكون ممتزجة تماماً وإلا سيكون الزبادي متكتل. اغلق الغطاء. اختر  في القائمة ثم اضغط . انتظر إلى أن ينتهي البرنامج. ضع الزبادي في الثلاجة ليبرد تماماً. سخن التوت برفق في مقلاة. أضف العسل. عندما يبدأ التوت في الهبوط، أخرجه من الحرارة ودعه يبرد ثم اخلطه مع الزبادي. إذا أردت حفظ الزبادي يجب تعقيم الجرار التي ستقوم باستخدامها. قم بتسخينها في فرن على 100 درجة مئوية لمدة 10 دقيقة. سيبقى الزبادي في الثلاجة لمدة تصل إلى أسبوعين.



فلفل لحم بقري حار

زيت زيتون	1	لحم بقري للقلبي	450 g
بصل، مفروم	2	ثوم، مقشر ومفروم	3
كمون مطحون	2	مسحوق فلفل حار	2
فلفل حريف	1	مسحوق فلفل أحمر مدخن/فلفل مكسيكي حار	1
طماطم	2	صلصة طماطم	2
ملح	1	فلفل أخضر	1
فلفل أسود	1	ورق الغار	1
فاصوليا رومي	1	أوراق ريحان، مفرومة بخشونة	1

فتح الغطاء. أضف الزيت. اختر  في القائمة ثم اضغط . قم بتقطيع اللحم والطماطم والفلفل إلى قطع صغيرة. قم بتحمير لحم البقر ثم أخرجه. أضف البصل والثوم وجميع الأعشاب. قم بطهي البصل إلى أن يلين. أضف اللحم. احفظ الفاصوليا. أضف المكونات المتبقية. اضغط على  مرتين لوقف البرنامج. اغلق الغطاء. اختر . أضف الفاصوليا قبل انتهاء الطهي بـ 30 دقيقة. إذا كان اللحم لا يزال صلباً قليلاً في نهاية البرنامج، أضف كوب من الماء وقم بتشغيل برنامج اللحم لمدة 30 دقيقة إضافية.

طاجن السمك المغربي

لحم أحمر، منزوع البذور ومفروم	2	فلفل أحمر، منزوع البذور ومفروم	1
بصل، مفروم	1	كرفس، مفروم	2
كركم	1	طماطم مقطعة	2
عود قرفة	1	كمون مطحون	1
عجينة هريسة	1	زنجبيل مطحون	1
مرقة سمك	120 ml	زبد أبيض	120 ml
معجون طماطم	1	سمك (سمك القد/سمك الحدوق/سمك السلمو)	675 g
ليمون	1	ملح ولفل	
ليمون	1	حفنة كزبرة صغيرة، مفرومة	1
زيتون أخضر	1		

احفظ الكزبرة. افتح الغطاء. أضف المكونات المتبقية. اغلق الغطاء. اختر  في القائمة ثم اضغط . قم بالطهي إلى أن يصبح السمك قشري (40-60 دقيقة). اضغط على  مرتين لوقف البرنامج. أضف الكزبرة. اضبط التوابل وقدم. سيكون ذلك رائعاً مع الكسكسي.

كيكة برواني الشوكولاته

كيكة برواني الشوكولاته	1150 ml	زبدة غير مملحة	170 g
بازلاء مقشرة	225 g	مسحوق كاكاو	170 g
(ثوم) مهروس	2	خلاصة الفانيليا	1
ورق الغار	1	قطرات شوكولاته باللبن	110 g
فلفل أسود			

للتقديم

أيس كريم فانيليا (اختياري)



أذب الزبدة في مقلاة على حرارة منخفضة. ثم بتبطين الوعاء بورق زبدة. قم بخفق الزبدة الذائبة والسكر ومسحوق الكاكاو والدقيق والبيض والفانيليا والملح في طبق. قم بلهها في قطرات الشوكولاته. ضع الخليط في الورق داخل الوعاء. اعلق الغطاء. اختر ☞ في القائمة. اضبط مدة الطهي على 1 ساعة و 30 دقيقة. اضغط على الزر ☞. يجب أن تكون الكيكة صلبة حول الحواف ولزجة قليلاً في الوسط. قدم الكيكة دافئة ومغطاة بالآيس كريم.

وجبة شعير مَقْشَر مع الفول البري في وعاء واحد

1	☞	الفول البري	1150 ml	كيكة برواني الشوكولاته
1		بصل، مفروم فرماً ناعماً	225 g	بازلاء مقشرة
1000 ml		مرقة خضار	2	☞ (ثوم مهروس)
125 ml		نبيذ أحمر جاف	1	☞ ورق الغار
2	☞	(بقودونس (مفروم)		فلفل أسود

زيت فلفل حار (اختياري)

افتح الغطاء. اختر ☞ في القائمة ثم اضغط ☞. أضف المرق. قم بالغلي مع التقليب. قم بالطهي على نار خفيفة لمدة 10 دقائق. انقل المرقة إلى إبريق. أضف الزيت. أضف البصل واللحم المقلي إلى أن يلين. أضف النبيذ وقم بالطهي لمدة بضع دقائق. أضف الشعير المَقْشَر وقلب إلى أن يبدأ في اكتساب لون النبيذ. قم بتفريغ الفاصوليا وإضافتها. أضف الطماطم. أضف المرق. اضغط على ☞ مرتين لوقف البرنامج. اعلق الغطاء. اختر ☞. افتح الغطاء قبل انتهاء الطهي بـ 30 دقيقة. تحقق من كمية السائل في الوعاء. أضف 150 مل من الماء الساخن إذا لزم الأمر. اعلق الغطاء. انتظر إلى أن ينتهي البرنامج. يقدم مع خبز يابس طازج ورشة من زيت الفلفل الحار

خرشوف بالببخار

2 خرشوف كروي

1 ☞ ثوم، مَقْشَر ومفروم

1 ليمون

أغصان من الأعشاب (طرخون ونعناع وبقودونس وزعتر)

قم بتقطيع الليمون. اقطع الساق مع أسفل كل خرشوفة. اقطع الربع العلوي من كل خرشوفة. تخلص من أي أوراق تالفة. قم بحك الأسطح المقطوعة بشريحة من الليمون. ضع شرائح الليمون في السلة. أضف أغصان الأعشاب. أضف الثوم. ضع في الخرشوف في الأعلى. املاً بالماء إلى المستوى 2 على المقياس الموجود على اليسار داخل الوعاء. ضع السلة فوق الوعاء. يتم طهي الخرشوف عندما يمكن نزع الأوراق الخارجية بسهولة. يقدم دافئاً ☞. في القائمة ثم اضغط ☞ اعلق الغطاء. اختر أو بارداً بصلصة خل. مدهش

البودنغ الإسفنجي الشراب

115 g زبد

100 g سكر ناعم

2 ☞

4 ☞ شراب ذهبي

¼ خلاصة الفانيليا

اخفق البيض في وعاء. اخفق الزبدة والسكر في وعاء. أضف تدريجياً البيض ثم الفانيليا ثم الدقيق. قلب في اللبن. قم بتشحميم وعاء 1200 مل مقاوم للحرارة. ضع الشراب في أسفل الوعاء المقاوم للحرارة وضع الخليط على القمة. قم بتغطيته بورق خبز ثم بورق معدني واربط الرأس برباط. افتح الغطاء. ضع الوعاء المقاوم للحرارة داخل الوعاء في الجهاز. أضف ما يكفي من الماء المغلي في الوعاء في الجهاز ليصل إلى 3 سم تحت قمة الوعاء المقاوم للحرارة. اعلق الغطاء. اختر ☞ في القائمة. اضبط مدة الطهي على 1 ساعة و 30 دقيقة. اضغط على الزر ☞. انتظر إلى أن ينتهي البرنامج. يقلب على طبق ويقدم دافئاً. هذا البودنغ عظيم في أي وقت في السنة!!

المرغيف الأبيض

خميرة مجففة	1 1/2	شراب ذهبي	1 1/2
دقيق خبز أبيض قوي	500 g	زبد	1 1/2
ملح	1 1/2	حليب	320 ml

افتح الغطاء. أضف اللبن. اختر 1/2 في القائمة ثم اضغط 1/2. دع اللبن يسخن إلى أن يبدأ في الغليان عند الحواف. انقل اللبن إلى إبريق. اضغط على 1/2 مرتين لوقف البرنامج. دع اللبن يبرد إلى ما بين 37 درجة مئوية و 45 درجة مئوية. أذب الزبدة في مقلاة على حرارة منخفضة. اخلط الدقيق والملح في وعاء. أضف الخميرة والزبدة والشراب. أضف اللبن واعجنه على شكل كرة. إذا كان الخليط لزجاً جداً، أضف قليلاً من الدقيق. قم بتغطيته واتركه في مكان دافئ لمدة 10 دقيقة. اعجن مرة أخرى. قم بتغطيته واتركه في مكان دافئ لمدة 10 دقيقة. افتح الغطاء. اختر 1/2 في القائمة ثم اضغط 1/2. اغلق الغطاء. افتح الغطاء قبل انتهاء الطهي بـ 30 دقيقة. اقلب الخبز. سوف يساعد ذلك على إكساب المرغيف قليلاً من اللون والمضغ. انتظر إلى أن ينتهي البرنامج. يقدم بكثير من الزبدة.

خبز الصودا

شراب ذهبي	1 1/2
زبد	1 1/2
حليب	320 ml
زبد	

افتح الغطاء. قم بتشجيع الوعاء بزبدة. اختر 1/2 في القائمة. اغلق الغطاء. اضبط مدة الطهي على 2 ساعة و 15 دقيقة. اضغط على الزر 1/2. اتركه يندفأ. وضع خليط خبز الصودا في وعاء. أضف الماء. اخلطه باليد على شكل كرة. افتح الغطاء. ضع العجين في الوعاء. قسم العجينة إلى أربع بملعقة بلاستيكية. اغلق الغطاء. افتح الغطاء قبل انتهاء الطهي بـ 30 دقيقة. اقلب الخبز. سوف يساعد ذلك على إكساب المرغيف قليلاً من اللون والمضغ. انتظر إلى أن ينتهي البرنامج. بارد على حامل من السلك. يقدم بزبدة مملحة أو مع وجبة.

العصيدة

دقيق شوفان	2 1/2
سكر	2 1/2
ماء	
ملح	1/4 1/2

للتقديم:

لبن/قشدة قليلة الدسم



سكر بني غامق

افتح الغطاء. أضف الشوفان والملح والسكر. املا بالماء إلى المستوى 1/2 على المقياس الموجود على اليسار داخل الوعاء. اغلق الغطاء. اختر 1/2 في القائمة ثم اضغط 1/2. انتظر إلى أن ينتهي البرنامج. يقدم باللبن أو القشدة. يرش بسكر بني غامق. يمكنك إذا أردت، إضافة مشمش مجفف مقطع أو خوخ نصفين (دون نواة) قبل 15 دقيقة من نهاية مدة الطهي. ويمكن الاحتفاظ بالعصيدة المتبقية في الثلاجة لمدة تصل إلى يومين ثم إعادة تسخينها.

العصيدة بالجوز

ماء		شوفان مجروش	1/2 كوب
حليب	ml 120	جوز هند مجفف	3
		قرفة مطحونة	1







للتقديم:

افتح الغطاء. أضف الشوفان والقرفة وجوز الهند واللين. املاً بالماء إلى المستوى 1/2 على المقياس الموجود على اليسار داخل الوعاء. اغلق الغطاء. اختر  في القائمة ثم اضغط . انتظر إلى أن ينتهي البرنامج. قم برش العصير الذهبي مع اللوز المحبب على القمة.

ريستو الشمندر بالطبخ المتعدد

زيت زيتون	2	بصل، مفروم فرماً ناعماً	1
جذر شمندر	g 400	ثوم، مقشر ومفروم	2
نبيذ أبيض	ml 250	أرز أربوري/ريستو	g 250
زعترا، مفروم فرماً ناعماً	1	مرقة خضار / مرقة دجاج	ml 900

للإنهاء:

بالطهي على نار خفيفة لمدة 10 دقائق. أضف المرق. قم بالقليب مع التقليب. قم  في القائمة ثم اضغط  افتح الغطاء. اختر  قشر الشمندر  في القائمة ثم اضغط  مرتين لوقف البرنامج. اختر  أنقل المرقة إلى إبريق. اضغط على وقطعه إلى مكعبات بطول 1 سم. ضع الشمندر والثوم والبصل في الوعاء. قم بطهي البصل إلى أن يلين. قلب في الأرز. أغلق بالطهي لمدة 3-4 دقائق. افتح الغطاء. بالطهي لمدة 3-4 دقائق. افتح الغطاء. قلب في النبيذ. أغلق الغطاء وقم الغطاء وقم أضف الزعتر. أضف المرق. اغلق الغطاء. انتظر إلى أن ينتهي البرنامج. تحقق من الأرز - يجب أن يكون به عضة طفيفة بالطهي لبضع دقائق أكثر. قلب في الزبدة ولكن لا ينبغي أن يكون صلباً. إذا لم يكن مطبوخاً تماماً، أضف قليلاً من الماء وقم - فهذا يعطي الريستو بريقه يقدم بقليل من الزيادي ويرش بالبقدونس هذا جيد حقاً كبدائى أو كوجبة غداء خفيفة





الأرز المتبل

ماء		أرز	2
جزر، مقطع	2	(مكعب مرقة (خضروات	1
كرفس، مفروم	2	فلفل أحمر، منزوع البذور ومفروم	1
كركم	1	(بازلاء (اختياري	1

افتح الغطاء. ضع الأرز في الوعاء. املاً بالماء إلى المستوى 2 على المقياس الموجود على اليسار داخل الوعاء. اهرس مكعب المرقة وقلبه في الماء. أضف المكونات المتبقية. اغلق الغطاء. اختر . انتظر إلى أن ينتهي البرنامج ثم قدمه. إذا لم يكن الأرز مطبوخاً تماماً، اتركه بضع دقائق مع غلق الغطاء ليصدر بخاراً.



حساء الطماطم

بطاطس	2	بصل، مفروم	1
زيت زيتون	1	مرقة دجاج	550 ml
طماطم مقطعة	1	أعشاب مجففة مختلطة	1
طماطم مقطعة	2	معجون طماطم	1
فلفل حلو مدبب	1	فلفل أسود	1

افتح الغطاء. أضف المرق. اختر  في القائمة ثم اضغط . قم بالغلي مع التقليب. قم بالطهي على نار خفيفة لمدة 10 دقائق. انقل المرققة إلى إبريق. اضغط على  مرتين لوقف البرنامج. قم بتقسير وتقطيع البطاطس. اختر  في القائمة ثم اضغط . أضف الزيت. أضف البصل والفلفل الحلو. قم بطهي البصل إلى أن يلين. أضف المرق. أضف المكونات المتبقية. اغلق الغطاء. انتظر إلى أن ينتهي البرنامج. اضبط التوابل. يقدم مع خبز بابيس.





الدجاج بالطماطم والفطر

صدور دجاج مخلية وبالعظم	2	صلصة طماطم	1
زيت زيتون	1	زعتر مجفف	1
فطر بني، مقطع	450 g	ملح وفلفل	1
ثوم، مقشر ومفروم	2	طماطم مقطعة	1
صلصة رسيستيرشاير	1	صلصة رسيستيرشاير	1

افتح الغطاء. اختر  في القائمة ثم اضغط . أضف الزيت. قم بتبديل صدور الدجاج بالملح والفلفل وضعها في الوعاء. اقلب اللحم لتغطية الجانبين. أضف الثوم والفطر. قم بالطهي لمدة 3 إلى 4 دقائق مع تدوير الدجاج مرة واحدة. أضف الطماطم وصلصة رسيستيرشاير وصلصة الطماطم والزعتر. قم بالطهي مع تدوير الدجاج مرة أخرى. تأكد من طهي الدجاج جيداً. يقدم مع معكرونة أو بطاطس أو أرز. وجبة سريعة ولذيذة يمكن حفظها في خزانة.

وجبة صدر حيوان في وعاء واحد

صدر حيوان	1 kg	جزر	2
مقطع، خنزير لحم سحج	50 g	كرفس	3
ثوم، مقشر ومفروم	2	مرقة بقر	600 ml
بصل أحمر، مفروم	2	طماطم مقطعة	1
(بطاطس) صغيرة	6-8	معجون طماطم	2
أعشاب مجففة مختلطة	2	روزماري، مقطع	2
صلصة رسيستيرشاير	2	ملح وفلفل	2

اترك الجلود على البطاطس. قم بتقطيع البطاطس والجزر والكرفس إلى قطع صغيرة. قم بتبديل صدر الحيوان بملح وفلفل. افتح الغطاء. اختر  في القائمة ثم اضغط . أضف المرق. قم بالغلي مع التقليب. قم بالطهي على نار خفيفة لمدة 10 دقائق. انقل المرققة إلى إبريق. قم بقلبي السحج لمدة دقيقتين. أضف اللحم. قم بتحميمير كل شيء. أضف البصل والثوم والبطاطس والكرفس والجزر. إذا كان لديك أي خضروات جذرية أخرى تحتاج لاستخدامها، أضفها أيضاً. قم بطهي البصل إلى أن يلين. أضف المرق. أضف المكونات المتبقية. اضغط على  مرتين لوقف البرنامج. اختر . انتظر إلى أن ينتهي البرنامج ثم قدمه. لن يضر الطهي لمدة 8 ساعات ولكن من المحتمل أن يكون جاهزاً للأكل بعد 5 ساعات.



Ovaj dokument je originalno proizveden i objavljen od strane proizvođača, brenda Russell Hobbs, i preuzet je sa njihove zvanične stranice. S obzirom na ovu činjenicu, Tehnoteka ističe da ne preuzima odgovornost za tačnost, celovitost ili pouzdanost informacija, podataka, mišljenja, saveta ili izjava sadržanih u ovom dokumentu.

Napominjemo da Tehnoteka nema ovlašćenje da izvrši bilo kakve izmene ili dopune na ovom dokumentu, stoga nismo odgovorni za eventualne greške, propuste ili netačnosti koje se mogu naći unutar njega. Tehnoteka ne odgovara za štetu nanесenu korisnicima pri upotrebi netačnih podataka. Ukoliko imate dodatna pitanja o proizvodu, ljubazno vas molimo da kontaktirate direktno proizvođača kako biste dobili sve detaljne informacije.

Za najnovije informacije o ceni, dostupnim akcijama i tehničkim karakteristikama proizvoda koji se pominje u ovom dokumentu, molimo posetite našu stranicu klikom na sledeći link:

<https://tehnoteka.rs/p/russell-hobbs-multicooker-21850-56-akcija-cena/>