

Uputstvo za upotrebu (EN)

PHANTEKS kućište Eclipse P200 Air

PHANTEKS



Tehnoteka je online destinacija za upoređivanje cena i karakteristika bele tehnike, potrošačke elektronike i IT uređaja kod trgovinskih lanaca i internet prodavnica u Srbiji. Naša stranica vam omogućava da istražite najnovije informacije, detaljne karakteristike i konkurentne cene proizvoda.

Posetite nas i uživajte u ekskluzivnom iskustvu pametne kupovine klikom na link:

<https://tehnoteka.rs/p/phanteks-kuciste-eclipse-p200-air-akcija-cena/>

INSTRUCTION MANUAL

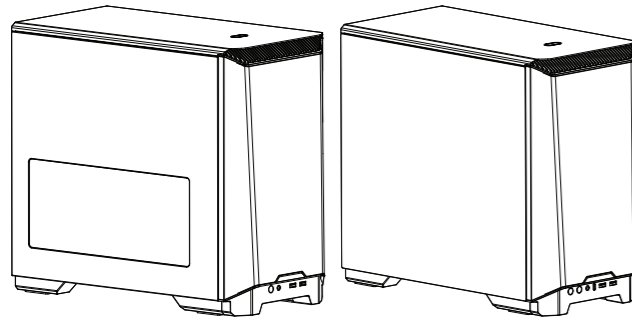

INTRODUCTION

Thank you for choosing Phanteks. Please take a moment to carefully go through the manual. Phanteks will not take responsibility for any damages incurred due to incorrect installation or usage of this product.

This manual supports the following models:
 PH-EC200AC_BK (2x 120 mm Black Fans)
 PH-EC200ATG_DBK (2x 120 mm D-RGB Fans)

PRODUCT OVERVIEW

CLEARANCE CPU Cooler Height 165 mm GPU Clearance 355 mm GPU Thickness 3-slot, 65mm	FRONT 120 FAN 140 FAN 120 RAD 140 RAD	SIDE 120 FAN 120 RAD	BOTTOM 120 FAN	REAR 120 FAN 120 RAD
P200A PRE-INSTALLED ACCESSORIES: 2x 120 mm Black or 2x 120 mm D-RGB 2x SSD Cover	P200A INCLUDED ACCESSORIES: 6x Zip Ties 21x Motherboard + SSD Screw 4x PSU Screw 3x Case Screw 1x Thumb Screw 1x Vertical GPU Mount			

FRONT I/O FEATURES

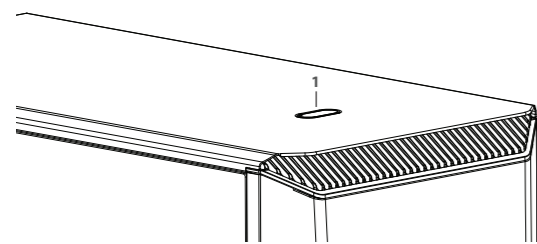

English	Français	Deutsch	Espanol
1. Power Button	1. Bouton d'alimentation	1. Ein-/Aus Schalter	1. Botón de encendido
2. Reset Button (P200AC Only)	2. Bouton de réinitialisation (P200AC Only)	2. Reset-Knopf (P200AC Only)	2. Botón de reinicio (P200AC Only)
3. D-RGB Mode (P200ATG-D Only)	3. D-RGB Mode (P200ATG-D Only)	3. D-RGB Mode (P200ATG-D Only)	3. D-RGB Mode (P200ATG-D Only)
4. D-RGB Color (P200ATG-D only)	4. D-RGB Color (P200ATG-D only)	4. D-RGB Color (P200ATG-D Only)	4. D-RGB Color (P200ATG-D Only)
5. Headphone / Microphone	5. Casque / Microphone	5. Kopfhörer / Mikrofon	5. Auricular / Micrófono
6. USB-C Gen 2 (P200ATG-D only)	6. USB-C Gen 2 (P200ATG-D only)	6. USB-C Gen 2 (P200ATG-D only)	6. USB-C Gen 2 (P200ATG-D only)
7. USB 3.0	7. USB 3.0	7. USB 3.0	7. USB 3.0

ECLIPSE P200A Performance (PH-EC200AC_BK)

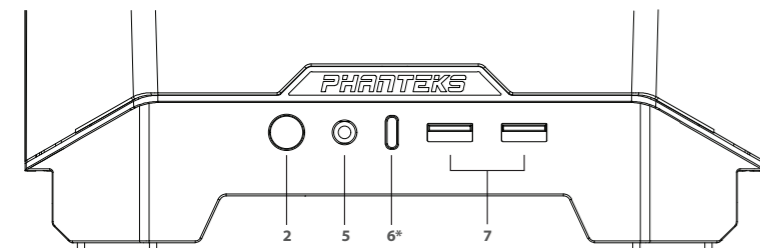

*Optional upgrade

ECLIPSE P200A DIGITAL-RGB (PH-EC200ATG_DBK)

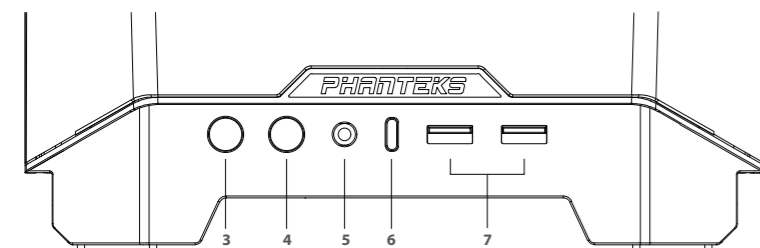

DIGITAL-RGB CONTROLS (P200ATG_D MODEL)

M MODES
 ● SOLID
 ● BREATHING
 ● RADAR
 ● SPARKLE
 ● RAINBOW

● COLORS

M PRESS AND HOLD THE MODE BUTTON TO TURN OFF LEDS
 2 SEC PRESS AGAIN TO TURN ON

STEP 1. REMOVING CHASSIS PANELS

a. PULL THE SIDE PANEL, THEN LIFT THE PANEL UP TO REMOVE IT

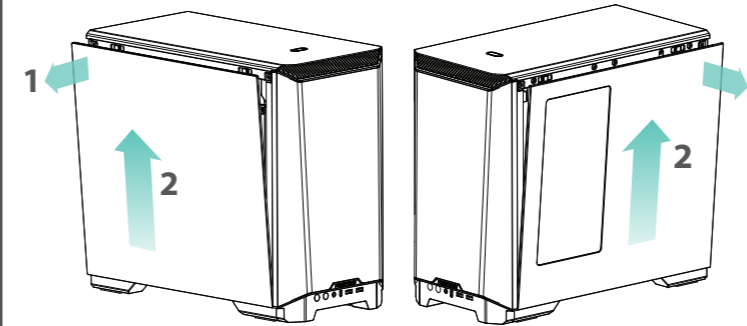

b. REMOVE FRONT PANEL BY PULLING ON THE PANEL FROM BELOW

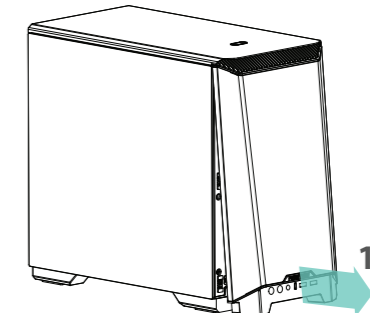

c. REMOVE THE BOTTOM DUST FILTER FROM THE FRONT

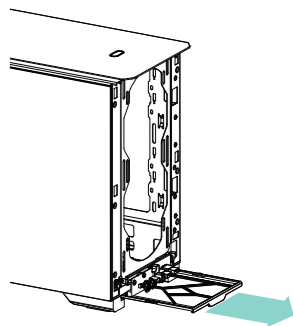

STEP 2. MOTHERBOARD INSTALLATION

INSTALL THE ITX MOTHERBOARD WITH 4x MOTHERBOARD SCREWS

INSTALL: 4x

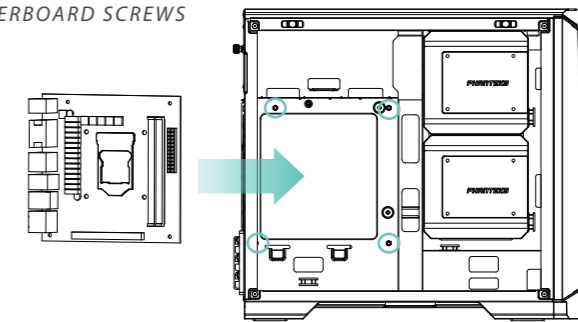

STEP 3. POWER SUPPLY INSTALLATION

THE POWER SUPPLY IS INSTALLED THROUGH THE REAR OF THE CHASSIS. LOOSEN THUMBSCREWS TO REMOVE PSU BRACKET. INSTALL PSU TO BRACKET WITH 4x PSU SCREWS.

LOOSEN: 2x

INSTALL: 4x

PRO TIP Plug in all cables you need for your build into the power supply first before installing it for easier installation

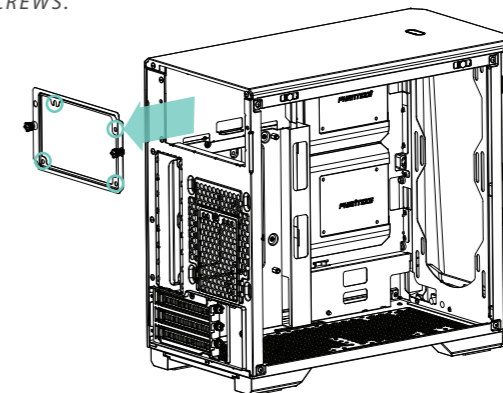

PRO TIP The right-side panel can be secured with a screw if cables are pushing against it.

STEP 4. STORAGE INSTALLATION - Dedicated 2.5" SSD Bracket

INSTALL THE SSD(S) WITH 4x SSD SCREWS ON THE DEDICATED SSD BRACKET AND MOUNT IT BACK INTO THE CHASSIS.

INSTALL: 4x

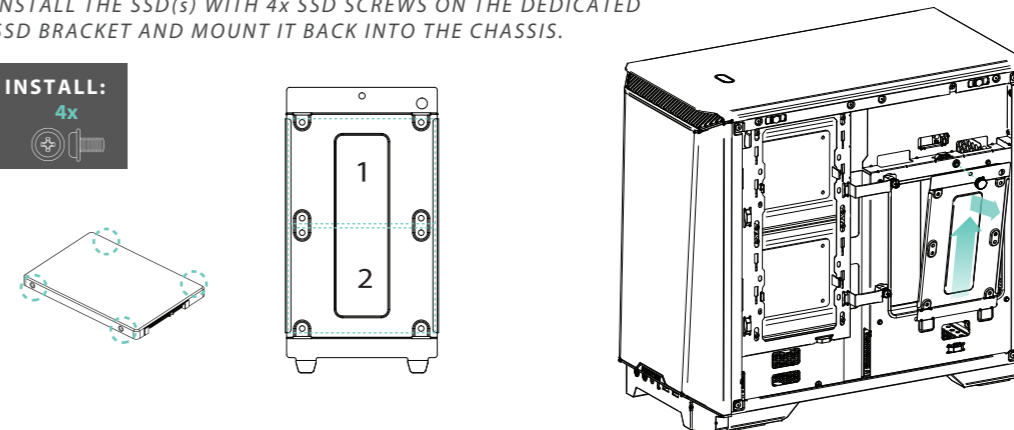

STEP 5. STORAGE INSTALLATION - 2.5" SSD Covers

INSTALL THE SSD DRIVE WITH 4x SSD SCREWS ON THE SSD COVER AND MOUNT BACK INTO THE CHASSIS.

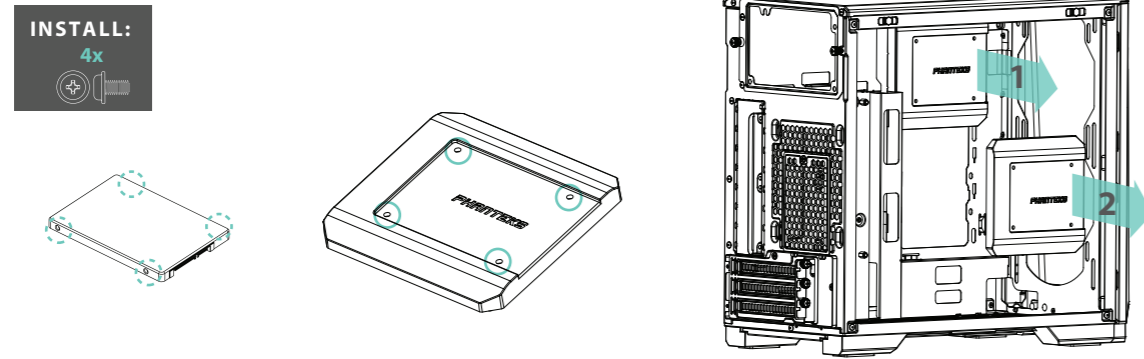

STEP 5. MOTHERBOARD CONNECTIONS

- a. CONNECT THE HD-AUDIO & USB 3.0 CABLES
- b. CONNECT THE FRONT I/O CABLES TO THE FRONT I/O HEADER ON THE MOTHERBOARD (SEE FRONT I/O HEADER DIAGRAM FOR GENERAL REFERENCE)

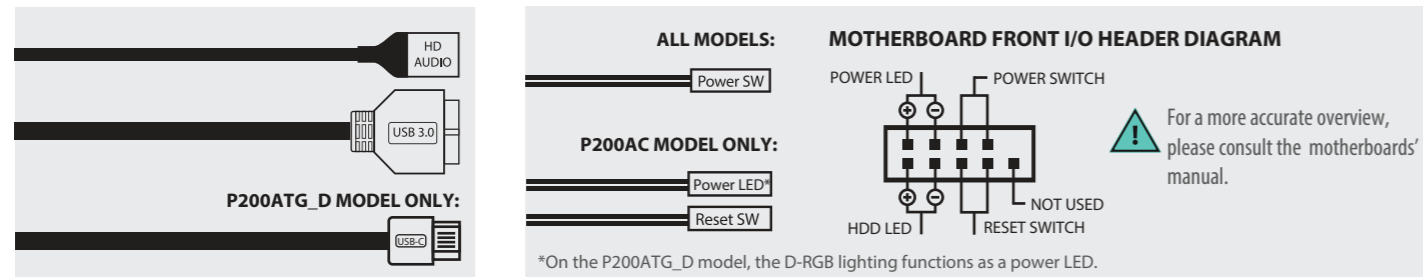

STEP 6. D-RGB LIGHTING - P200ATG_D MODEL ONLY

- a. CONNECT THE SATA CABLE TO THE POWER SUPPLY



CONNECT MORE D-RGB PRODUCTS

- b. CONNECT D-RGB CONNECTOR TO D-RGB PRODUCTS

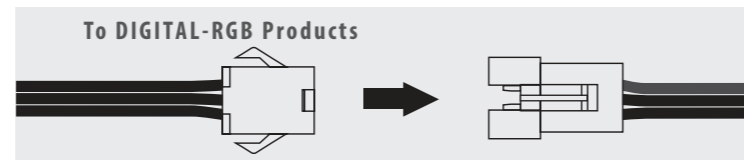

SYNC YOUR CASE LIGHTING TO THE MOTHERBOARD (OPTIONAL)

- c. CONNECT MOTHERBOARD D-RGB ADAPTER TO THE MOTHERBOARD

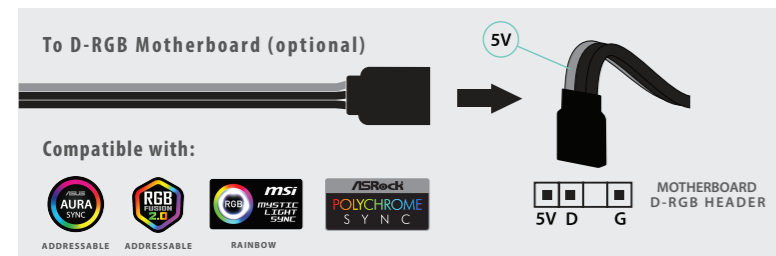

Lighting must be controlled through the motherboard software when connected to the motherboard. The Color and Mode buttons do not work when synced to motherboard.

OPTIONAL UPGRADES

STEP 7. VERTICAL GPU MOUNT - OPTIONAL (RISER CABLE SOLD SEPERATELY. PH-CBRS_FL15)

- a. Release the GPU brackets by removing 3 screws.
- b. Secure the GPU brackets as shown with the same 3 screws.

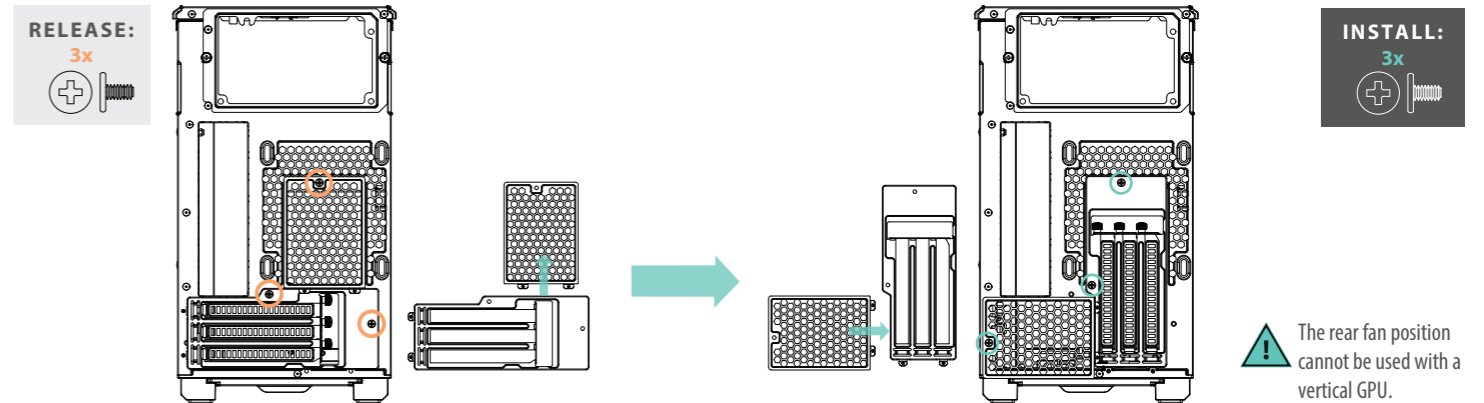

- c. Secure the GPU Mount to the bottom of the chassis with the 2 thumb screws. Secure the Riser Cable to the GPU Mount.

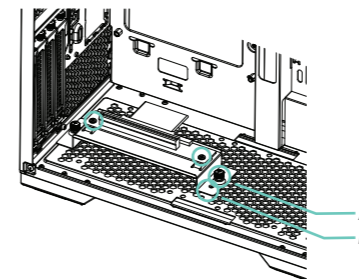

The GPU Mount has two mounting positions. Position A allows for better air cooling and 3-slot GPU cards.

STEP 8. STORAGE INSTALLATION - 3.5" HDD (STACKABLE HDD BRACKET SOLD SEPERATELY. PH-HDDKT_03)

Up to 4 Stackable HDD Brackets can be installed in the side fan locations. These are available separately.

- a. INSTALL THE HDD DRIVE INTO THE STACKABLE 3.5" HDD BRACKET.

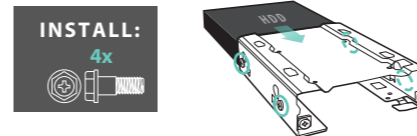

- b. STACK TWO BRACKETS WHEN INSTALLING MORE HDDs. IF NOT, SKIP THIS STEP.

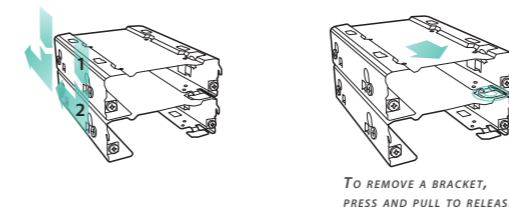

- d. MOUNT THE BRACKETS INTO THE CHASSIS AND SECURE EACH HDD WITH 2 THUMBSCREWS

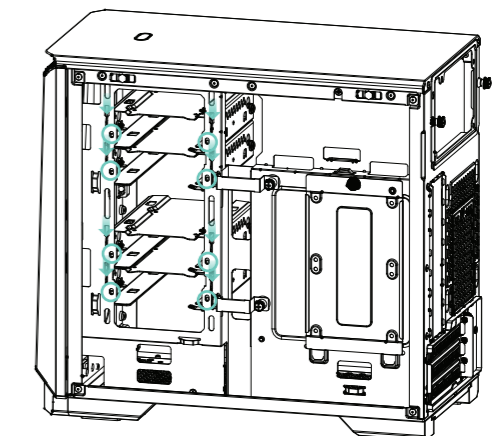
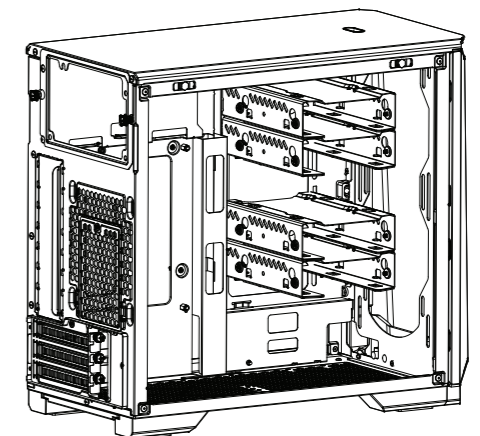

Ovaj dokument je originalno proizveden i objavljen od strane proizvođača, brenda PHANTEKS, i preuzet je sa njihove zvanične stranice. S obzirom na ovu činjenicu, Tehnoteka ističe da ne preuzima odgovornost za tačnost, celovitost ili pouzdanost informacija, podataka, mišljenja, saveta ili izjava sadržanih u ovom dokumentu.

Napominjemo da Tehnoteka nema ovlašćenje da izvrši bilo kakve izmene ili dopune na ovom dokumentu, stoga nismo odgovorni za eventualne greške, propuste ili netačnosti koje se mogu naći unutar njega. Tehnoteka ne odgovara za štetu nanесenu korisnicima pri upotrebi netačnih podataka. Ukoliko imate dodatna pitanja o proizvodu, ljubazno vas molimo da kontaktirate direktno proizvođača kako biste dobili sve detaljne informacije.

Za najnovije informacije o ceni, dostupnim akcijama i tehničkim karakteristikama proizvoda koji se pominje u ovom dokumentu, molimo posetite našu stranicu klikom na sledeći link:

<https://tehnoteka.rs/p/phanteks-kuciste-eclipse-p200-air-akcija-cena/>