

Informacije o proizvodu (EN)

SEAGATE hard disk 2TB ST2000VM003



Tehnoteka je online destinacija za upoređivanje cena i karakteristika bele tehnike, potrošačke elektronike i IT uređaja kod trgovinskih lanaca i internet prodavnica u Srbiji. Naša stranica vam omogućava da istražite najnovije informacije, detaljne karakteristike i konkurentne cene proizvoda.

Posetite nas i uživajte u ekskluzivnom iskustvu pametne kupovine klikom na link:

<https://tehnoteka.rs/p/seagate-hard-disk-2tb-st2000vm003-akcija-cena/>



Product Manual

Seagate® Video 3.5 HDD

ST3000VM002

ST2000VM003

ST1000VM002

100633414
Rev. M
May 2015

Document Revision History

Revision	Date	Description of changes
Rev. A	07/12/2010	Initial release (as Pipeline HD).
Rev. B	01/07/2011	Added to the feature list; updated specifications.
Rev. C	04/25/2011	Added updated AFR and warranty info; added AFR section. Updated words 88 and 89 in Table 7.
Rev. D	08/04/2011	Added 1TB model and related specifications.
Rev. E	03/25/2012	Added 2TB model and related specifications.
Rev. F	05/03/2012	Updated Table 2 (DC power requirements); clarified temperature description (Table 1 and 2.9.1)
Rev. G	11/29/2012	Updated environmental information on page 19.
Rev. H	05/14/2013	Updated product name to "Seagate Video 3.5 HDD" throughout.
Rev. J	02/25/2014	Added 3TB model and related specifications, Removed blank pages, renumbered all pages, Replaced Support page (page 1), updated Copyright (below), updated warranty URL & verify text (pages 5 & 15), Revised High instantaneous (burst) data-transfer rates (page 2) & updated Korean Cert Info (page 15)
Rev. K	05/08/2014	Pages 19-20. (added metric values to the mechanical drawings)
Rev. L	02/06/2015	Pages 7 & 10. (changed 1TB model Height to 20mm /.787in)
Rev. M	05/06/2015	Page 22-23 & 30. (fixed side hole dimension in mechanical drawings; added Streaming support commands)

© 2015 Seagate Technology LLC. All rights reserved.

Publication number: 100633414, Rev. M May 2015

Seagate, Seagate Technology and the Spiral logo are registered trademarks of Seagate Technology LLC in the United States and/or other countries. SeaTools are either trademarks or registered trademarks of Seagate Technology LLC or one of its affiliated companies in the United States and/or other countries. All other trademarks or registered trademarks are the property of their respective owners.

No part of this publication may be reproduced in any form without written permission of Seagate Technology LLC.

Call 877-PUB-TEK1 (877-782-8351) to request permission.

When referring to drive capacity, one gigabyte, or GB, equals one billion bytes and one terabyte, or TB, equals one trillion bytes. Your computer's operating system may use a different standard of measurement and report a lower capacity. In addition, some of the listed capacity is used for formatting and other functions, and thus will not be available for data storage. Actual quantities will vary based on various factors, including file size, file format, features and application software. Actual data rates may vary depending on operating environment and other factors. The export or re-export of hardware or software containing encryption may be regulated by the U.S. Department of Commerce, Bureau of Industry and Security (for more information, visit www.bis.doc.gov), and controlled for import and use outside of the U.S. Seagate reserves the right to change, without notice, product offerings or specifications.

Contents

Seagate® Technology Support Services	4
<hr/>	
1.0 Introduction	5
1.1 About the Serial ATA Interface	6
<hr/>	
2.0 Drive Specifications	7
2.1 Specification summary tables	7
2.2 Formatted capacity	9
2.2.1 LBA mode	9
2.3 Default logical geometry	9
2.4 Recording and interface technology	9
2.5 Physical characteristics	10
2.6 Seek time	10
2.7 Start/stop times	10
2.8 Power specifications	11
2.8.1 Power consumption	11
2.8.2 Conducted noise	13
2.8.3 Voltage tolerance	13
2.8.4 Power-management modes	14
2.9 Environmental specifications	14
2.9.1 Drive case temperature	14
2.9.2 Temperature gradient	15
2.9.3 Humidity	15
2.9.4 Altitude	15
2.9.5 Shock	15
2.9.6 Vibration	16
2.10 Acoustics	16
2.10.1 Test for Prominent Discrete Tones (PDTs)	16
2.11 Electromagnetic immunity	17
2.12 Reliability - Annualized Failure Rate	17
2.13 Warranty	18
2.14 Agency certification	18
2.14.1 Safety certification	18
2.14.2 Electromagnetic compatibility	18
2.14.3 FCC verification	19
2.15 Environmental protection	20
2.15.1 European Union Restriction of Hazardous Substances (RoHS) Directive	20
2.15.2 China Restriction of Hazardous Substances (RoHS) Directive	20
2.16 Corrosive environment	20
<hr/>	
3.0 Configuring and Mounting the Drive	21
3.1 Handling and static-discharge precautions	21
3.2 Configuring the drive	21
3.3 Serial ATA cables and connectors	21
3.4 Drive mounting	22
<hr/>	
4.0 Serial ATA Interface	24
4.1 Hot-Plug compatibility	24
4.2 Serial ATA device plug connector pin definitions	24
4.3 Supported ATA commands	25
4.3.1 Identify Device command	28
4.3.2 Set Features command	32
4.3.3 S.M.A.R.T. commands	33

Figures

Figure 1	Typical Current Profiles (5V)	12
Figure 2	Typical Current Profiles (12V)	13
Figure 3	Attaching SATA cabling.	21
Figure 4	Mounting dimensions (3TB and 2TB model)	22
Figure 5	Mounting dimensions (1TB model)	23

Seagate® Technology Support Services

For information regarding online support and services, visit <http://www.seagate.com/about/contact-us/technical-support/>

Available services include:

- Presales & Technical support
- Global Support Services telephone numbers & business hours
- Authorized Service Centers

For information regarding Warranty Support, visit: <http://www.seagate.com/support/warranty-and-replacements/>

For information regarding data recovery services, visit <http://www.seagate.com/services-software/data-recovery-services/>

For Seagate OEM and Distribution partner portal, visit: <http://www.seagate.com/partners/>

For Seagate reseller portal, visit: <http://www.seagate.com/partners/my-spp-dashboard/>

1.0 Introduction

This manual describes the functional, mechanical and interface specifications for the following:
Seagate® Video 3.5 HDD SATA model drives:

ST3000VM002

ST2000VM003

ST1000VM002

These drives provide the following key features:

- 5900 RPM spindle speed
- High instantaneous (burst) data-transfer rates with a default of 6Gb/s.
Limit settings for 1.5Gb/s and 3.0Gb/s are available via S.M.A.R.T. Command Transport command.
- Support for S.M.A.R.T. drive monitoring and reporting
- Perpendicular recording, Tunneling Magneto-resistive (TMR) recording heads and EPRML technology, for increased areal density
- State-of-the-art cache and on-the-fly error-correction algorithms
- Native Command Queuing with command ordering to increase performance in demanding applications
- Full-track multiple-sector transfer capability without local processor intervention
- Quiet operation
- Compliant with RoHS requirements in China and Europe
- SeaTools diagnostic software performs a drive self-test that eliminates unnecessary drive returns.
- Supports latching SATA cables and connectors
- Worldwide Name (WWN) capability uniquely identifies the drive.
- Supports Trusted Send/Receive Security Protocol
- Reliability for 24x7 video applications
- Supports ATA8 streaming commands
- Supports power-up in the standby feature
- Supports Trusted Send/Receive Security Protocol
- Performance-tuned for seamless video applications
- Built-in error recovery for non-stop video streaming
- Best-in-class acoustic performance means virtually silent operation
- Enhanced caching capabilities enable superior video recording quality.

1.1 About the Serial ATA Interface

The Serial ATA interface provides several advantages over the traditional (parallel) ATA interface. The primary advantages include:

- Easy installation and configuration with true plug-and-play connectivity. It is not necessary to set any jumpers or other configuration options.
- Thinner and more flexible cabling for improved enclosure airflow and ease of installation.
- Scalability to higher performance levels.

In addition, Serial ATA makes the transition from parallel ATA easy by providing legacy software support. Serial ATA was designed to allow users to install a Serial ATA host adapter and Serial ATA disk drive in the current system and expect all of the existing applications to work as normal.

The Serial ATA interface connects each disk drive in a point-to-point configuration with the Serial ATA host adapter. There is no master/slave relationship with Serial ATA devices like there is with parallel ATA. If two drives are attached on one Serial ATA host adapter, the host operating system views the two devices as if they were both “masters” on two separate ports. This essentially means both drives behave as if they are Device 0 (master) devices.

Note	The host adapter may, optionally, emulate a master/slave environment to host software where two devices on separate Serial ATA ports are represented to host software as a Device 0 (master) and Device 1 (slave) accessed at the same set of host bus addresses. A host adapter that emulates a master/slave environment manages two sets of shadow registers. This is not a typical Serial ATA environment.
-------------	---

The Serial ATA host adapter and drive share the function of emulating parallel ATA device behavior to provide backward compatibility with existing host systems and software. The Command and Control Block registers, PIO and DMA data transfers, resets, and interrupts are all emulated. The Serial ATA host adapter contains a set of registers that shadow the contents of the traditional device registers, referred to as the Shadow Register Block. All Serial ATA devices behave like Device 0 devices. For additional information about how Serial ATA emulates parallel ATA, refer to the “Serial ATA International Organization: Serial ATA Revision 3.0”. The specification can be downloaded from www.sata-io.org.

2.0 Drive Specifications

Unless otherwise noted, all specifications are measured under ambient conditions, at 25°C, and nominal power. For convenience, the phrases *the drive* and *this drive* are used throughout this manual to indicate the following drive models:

ST3000VM002

ST2000VM003

ST1000VM002

2.1 Specification summary tables

The specifications listed in the following tables are for quick reference. For details on specification measurement or definition, see the appropriate section of this manual.

Table 1 Drive specifications summary for 3TB, 2TB and 1TB models

Drive Specification	ST3000VM002	ST2000VM003	ST1000VM002
Formatted capacity (4K/sector)*	3000GB (3TB)	2000GB (2TB)	1000GB (1TB)
Guaranteed sectors	5,860,533,168	3,907,029,168	1,953,525,168
Heads	6	4	2
Disks	3	2	1
Bytes per sector	4K (512 bytes per sector emulated at the interface)		
Default sectors per track	63	63	63
Default read/write heads	16	16	16
Default cylinders	16,383	16,383	16,383
Recording density (max)	1807kFCI	1807kFCI	1807kFCI
Track density (avg)	352ktracks/in	352ktracks/in	352ktracks/in
Areal density (avg)	625Gfc/in ²	625Gfc/in ²	625Gfc/in ²
Spindle speed	5900 RPM	5900 RPM	5900 RPM
Internal data transfer rate (max)	2147Mb/s	2147Mb/s	2147Mb/s
Sustained data transfer rate OD	159MB/s	159MB/s	159MB/s
I/O data-transfer rate	600MB/s	600MB/s	600MB/s
ATA data-transfer modes supported	PIO modes: 0 to 4 Multiword DMA modes: 0 to 2 Ultra DMA modes: 0 to 6		
Cache buffer	64MB	64MB	64MB
Height (max)	26.1mm / 1.028 in	26.1mm / 1.028 in	20mm / 0.787 in
Width (max)	101.6mm / 4.0 in (± 0.010 in)	101.6mm / 4.0 in (± 0.010 in)	101.6mm / 4.0 in (± 0.010 in)
Length (max)	147.00mm / 5.78 in	147.00mm / 5.78 in	147.00mm / 5.78 in
Weight (typical)	626g / 1.38 lb	535g / 1.18 lb	415g / 0.915 lb
Average latency	5.1ms	5.1ms	5.1ms
Power-on to ready (max)	<17s	<17s	<6s
Standby to ready (max)	<17s	<17s	<6s
Track-to-track seek time (typical)	<1.0ms read; <1.2ms write	<1.0ms read; <1.2ms write	<1.0ms read; <1.2ms write
Average seek (typical)	<8.5ms read; <9ms write	<8.5ms read; <9ms write	<8.5ms read; <9ms write
Startup current (typical) 12V (peak)	2.0A	2.0A	2.0A

Table 1 Drive specifications summary for 3TB, 2TB and 1TB models

Drive Specification	ST3000VM002	ST2000VM003	ST1000VM002
Voltage tolerance (including noise)	5V: ± 5% 12V: ±10%	5V: ± 5% 12V: ±10%	5V: ± 5% 12V: ±10%
Operating temperature (drive case temperature)	0° to 75°C	0° to 75°C	0° to 75°C
Nonoperating temperature (ambient)	-40° to 70°C	-40° to 70°C	-40° to 70°C
Temperature gradient (max)	20°C per hour (operating) 30°C per hour (nonoperating)		
Relative humidity	5% to 95% (operating) 5% to 95% (nonoperating)		
Relative humidity gradient (max)	30% per hour	30% per hour	30% per hour
Wet bulb temperature (max)	37.7°C (operating) 40.0°C (nonoperating)		
Altitude, operating	-60.96m to 3048m (-200 to 10,000+ ft.)		
Altitude, nonoperating (below mean sea level, max)	-60.96m to 12,192m (-200 ft. to 40,000+ ft.)		
Operational Shock (max)	80 Gs at 2ms	80 Gs at 2ms	80 Gs at 2ms
Nonoperational Shock (max)	300 Gs at 2ms	300 Gs at 2ms	350 Gs at 2ms
Vibration, operating	2Hz-22Hz: 0.25 Gs, Limited displacement 22Hz-350Hz: 0.50 Gs 350Hz-500Hz: 0.25 Gs		
Vibration, nonoperating	5Hz-22Hz: 3.0 Gs 22Hz-350Hz: 3.0 Gs 350Hz-500Hz: 3.0 Gs		
Drive acoustics, sound power			
Idle**	2.1 bels (typical) 2.3 bels (max)	2.1 bels (typical) 2.3 bels (max)	1.9 bels (typical) 2.1 bels (max)
Seek	2.3 bels (typical) 2.4 bels (max)	2.3 bels (typical) 2.4 bels (max)	2.2 bels (typical) 2.3 bels (max)
Nonrecoverable read errors	1 per 10 ¹⁴ bits read	1 per 10 ¹⁴ bits read	1 per 10 ¹⁴ bits read
Annualized Failure Rate (AFR)	0.55%	0.55%	0.55%
Warranty	To determine the warranty for a specific drive, use a web browser to access the following web page: http://www.seagate.com/support/warranty-and-replacements/ From this page, click on "Check to see if the drive is under Warranty". Users will be asked to provide the drive serial number, model number (or part number) and country of purchase. The system will display the warranty information for the drive.		
Load/Unload cycles	300K at 25°C, 50% rel. humidity		
Supports Hotplug operation per the Serial ATA Revision 3.0 specification	Yes	Yes	Yes

*One GB equals one billion bytes and 1TB equals one trillion bytes when referring to hard drive capacity. Accessible capacity may vary depending on operating environment and formatting.

**During periods of drive idle, some offline activity may occur according to the S.M.A.R.T. specification, which may increase acoustic and power to operational levels

2.2 Formatted capacity

Model	Formatted capacity*	Guaranteed sectors	Bytes per sector
ST3000VM002	3TB	5,860,533,168	4096 (512 bytes per sector emulated at the interface)
ST2000VM003	2TB	3,907,029,168	
ST1000VM002	1TB	1,953,525,168	

* One GB equals one billion bytes and 1TB equals one trillion bytes when referring to hard drive capacity. Accessible capacity may vary depending on operating environment and formatting.

2.2.1 LBA mode

When addressing these drives in LBA mode, all blocks (sectors) are consecutively numbered from 0 to $n-1$, where n is the number of guaranteed sectors as defined above.

See Section 4.3.1, "Identify Device command" (words 60-61 and 100-103) for additional information about 48-bit addressing support of drives with capacities over 137GBs.

2.3 Default logical geometry

Cylinders	Read/write heads	Sectors per track
16,383	16	63

LBA mode

When addressing these drives in LBA mode, all blocks (sectors) are consecutively numbered from 0 to $n-1$, where n is the number of guaranteed sectors as defined above.

2.4 Recording and interface technology

	ST3000VM002	ST2000VM003	ST1000VM002
Interface	SATA	SATA	SATA
Recording method	Perpendicular	Perpendicular	Perpendicular
Recording density (max)	1807kFCI	1807kFCI	1807kFCI
Track density (avg)	352ktracks/in	352ktracks/in	352ktracks/in
Areal density (avg)	625Gfc/in ²	625Gfc/in ²	625Gfc/in ²
Spindle speed (RPM)	5900 ± 0.2%	5900 ± 0.2%	5900 ± 0.2%
Internal data transfer rate (max)	2147Mb/s	2147Mb/s	2147Mb/s
Sustained data transfer rate (max)	159MB/s	159MB/s	159MB/s
I/O data-transfer rate (max)	600MB/s	600MB/s	600MB/s

2.5 Physical characteristics

Maximum height	
3TB model	26.1mm / 1.028 in
2TB model	26.1mm / 1.028 in
1TB model	20mm / 0.787 in
Maximum width	101.6mm / 4.0 in (± 0.010 in)
Maximum length	147.00mm / 5.78 in
Typical weight	
3TB model	626g / 1.38 lb
2TB model	535g / 1.18 lb
1TB model	415g / 0.915 lb
Cache buffer	64MB (65,536kb)

2.6 Seek time

Seek measurements are taken with nominal power at 25°C ambient temperature. All times are measured using drive diagnostics. The specifications in the table below are defined as follows:

- Track-to-track seek time is an average of all possible single-track seeks in both directions.
- Average seek time is a true statistical random average of at least 5000 measurements of seeks between random tracks, less overhead.

	3TB		2TB		1TB	
Typical seek times (ms)	Read	Write	Read	Write	Read	Write
Track-to-track	<1.0	<1.2	<1.0	<1.2	<1.0	<1.2
Average	<8.5	<9.0	<8.5	<9.0	<8.5	<9.0
Average latency	5.1	5.1	5.1	5.1	5.1	5.1

Note	These drives are designed to consistently meet the seek times represented in this manual. Physical seeks, regardless of mode (such as track-to-track and average), are expected to meet the noted values. However, due to the manner in which these drives are formatted, benchmark tests that include command overhead or measure logical seeks may produce results that vary from these specifications.
-------------	---

2.7 Start/stop times

Start/stop times @ 25°C	3TB model	2TB model	1TB model
Power-on to ready (max)	<17.0s	<17.0s	< 6.0s
Standby to ready (max)	<17.0s	<17.0s	< 6.0s
Ready to spindle stop (max)	10.0s	10.0s	10.0s

2.8 Power specifications

The drive receives DC power (+5V or +12V) through a native SATA power connector. (Refer to [Figure 3](#)).

2.8.1 Power consumption

Power requirements for the drives are listed in [Table 3 on page 11](#). Typical power measurements are based on an average of drives tested, under nominal conditions, using 5.0V and 12.0V input voltage at 25°C ambient temperature.

- **Spinup power**
Spinup power is measured from the time of power-on to the time that the drive spindle reaches operating speed.
- **Read/write power and current**
Read/write power is measured with the heads on track, based on a 16-sector write followed by a 32-ms delay, then a 16-sector read followed by a 32-ms delay.
- **Operating power and current (CE profile)**
Operating power is measured by simulating a typical PVR operating environment, using a 50% write, 50% read algorithm.
- **Idle mode power**
Idle mode power is measured with the drive up to speed, with servo electronics active and with the heads in a random track location.
- **Standby mode**
During Standby mode, the drive accepts commands, but the drive is not spinning, and the servo and read/write electronics are in power-down mode.

Table 2 DC power requirements for 3TB models

Power dissipation (3-disk values shown)	Avg (watts 25°C)	Avg 5V typ amps	Avg 12V typ amps
Spinup	—	—	2.0
Idle* †	4.923	0.291	0.289
Operating	5.65	0.302	0.345
Standby	0.819	0.15	0.005
Sleep	0.819	0.15	0.005

Table 3 DC power requirements for 2TB models

Power dissipation (2-disk values shown)	Avg (watts 25°C)	Avg 5V typ amps	Avg 12V typ amps
Spinup	—	—	2.0
Idle* †	3.7418	0.221	0.219
Operating	5.05	0.302	0.295
Standby	0.819	0.15	0.005
Sleep	0.819	0.15	0.005

*During periods of drive idle, some offline activity may occur according to the S.M.A.R.T. specification, which may increase acoustic and power to operational levels.

†5W IDLE, Standby and Sleep, with DIPLM enabled

Table 4 DC power requirements for 1TB models

Power dissipation (1-disk values shown)	Avg (watts 25°C)	Avg 5V typ amps	Avg 12V typ amps
Spinup	—	—	2.0
Idle* †	2.502	0.152	0.145
Operating	3.676	0.385	0.145
Standby	0.819	0.15	0.005
Sleep	0.819	0.15	0.005

*During periods of drive idle, some offline activity may occur according to the S.M.A.R.T. specification, which may increase acoustic and power to operational levels. Measurement was taken in Idle 1 mode.

†5W IDLE, Standby and Sleep, with DIPLM enabled

Figure 1 Typical Current Profiles (5V)

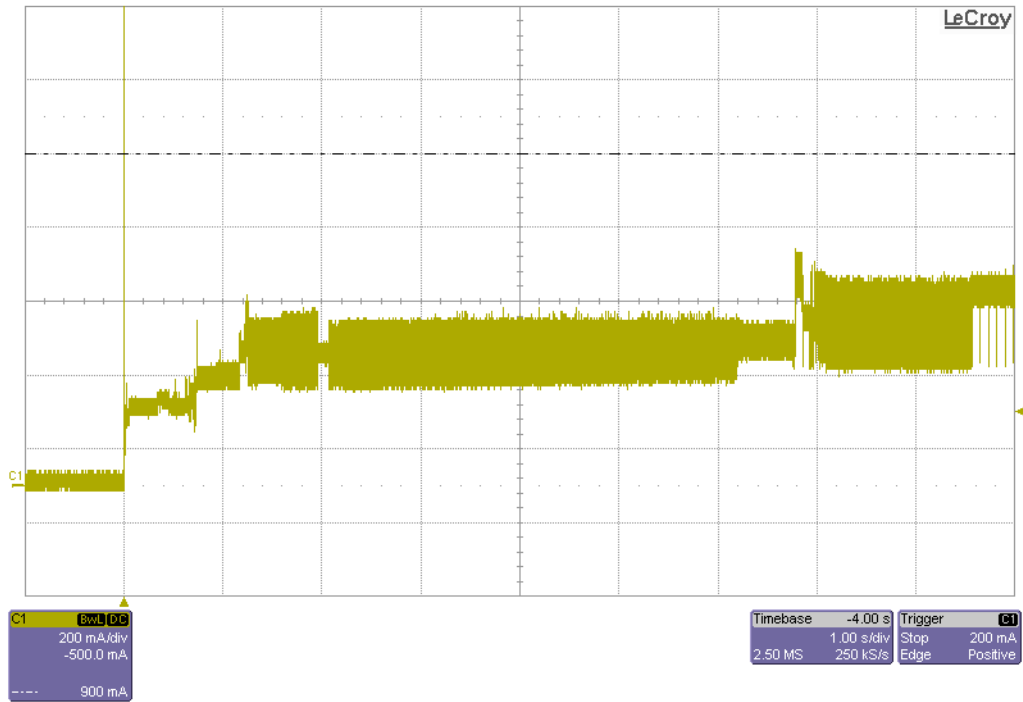
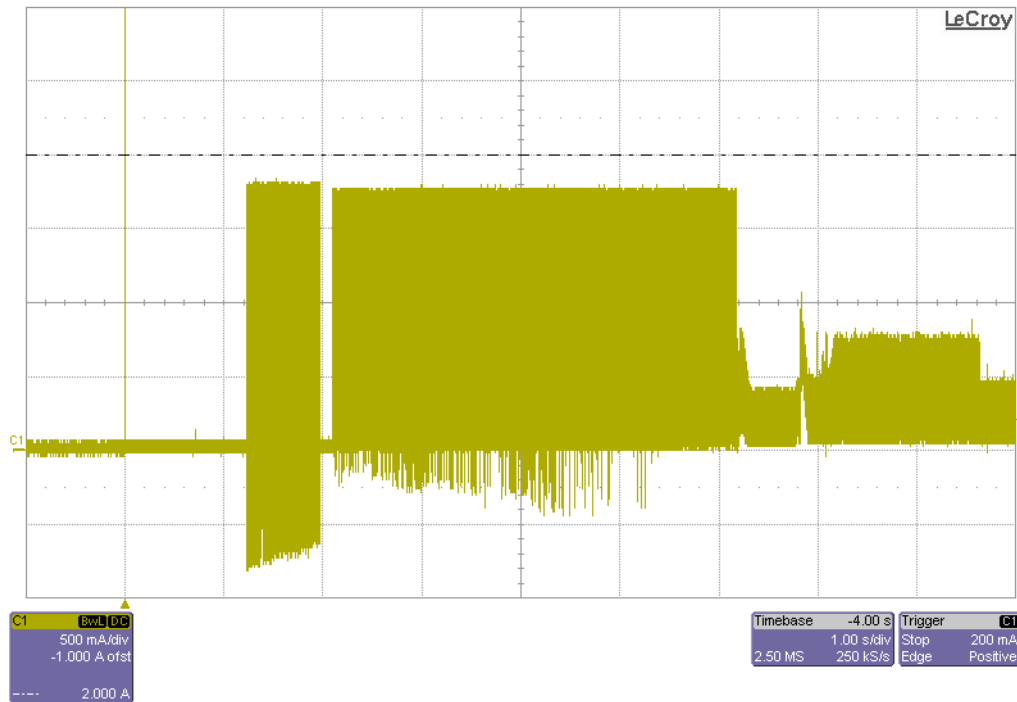

Figure 2 Typical Current Profiles (12V)



2.8.2 Conducted noise

Input noise ripple is measured at the host system power supply across an equivalent 80-ohm resistive load on the +12V line or an equivalent 15-ohm resistive load on the +5V line.

- Using 12V power, the drive is expected to operate with a maximum of 120 mV peak-to-peak square-wave injected noise at up to 10MHz.
- Using 5V power, the drive is expected to operate with a maximum of 100 mV peak-to-peak square-wave injected noise at up to 10MHz.

Note. Equivalent resistance is calculated by dividing the nominal voltage by the typical RMS read/write current.

2.8.3 Voltage tolerance

Voltage tolerance (including noise):

- 5V: $\pm 5\%$
- 12V: $\pm 10\%$

2.8.4 Power-management modes

The drive provides programmable power management to provide greater energy efficiency. In most systems, users can control power management through the system setup program. The drive features the following power-management modes:

Power modes	Heads	Spindle	Buffer
Active	Tracking	Rotating	Enabled
Idle	Tracking	Rotating	Enabled
Standby	Parked	Stopped	Enabled
Sleep	Parked	Stopped	Disabled

- **Active mode**
The drive is in Active mode during the read/write and seek operations.
- **Idle mode**
The buffer remains enabled, and the drive accepts all commands and returns to Active mode any time disk access is necessary.
- **Standby mode**
The drive enters Standby mode when the host sends a Standby Immediate command. If the host has set the standby timer, the drive can also enter Standby mode automatically after the drive has been inactive for a specifiable length of time. The standby timer delay is established using a Standby or Idle command. In Standby mode, the drive buffer is enabled, the heads are parked and the spindle is at rest. The drive accepts all commands and returns to Active mode any time disk access is necessary.
- **Sleep mode**
The drive enters Sleep mode after receiving a Sleep command from the host. In Sleep mode, the drive buffer is disabled, the heads are parked and the spindle is at rest. The drive leaves Sleep mode after it receives a Hard Reset or Soft Reset from the host. After receiving a reset, the drive exits Sleep mode and enters Standby mode with all current translation parameters intact.
- **Idle and Standby timers**
Each time the drive performs an Active function (read, write or seek), the standby timer is reinitialized and begins counting down from its specified delay times to zero. If the standby timer reaches zero before any drive activity is required, the drive makes a transition to Standby mode. In both Idle and Standby mode, the drive accepts all commands and returns to Active mode when disk access is necessary.

2.9 Environmental specifications

2.9.1 Drive case temperature

This section provides the temperature, humidity, shock, and vibration specifications. Ambient temperature is defined as the temperature of the environment immediately surrounding the drive. Above 1000ft. (305 meters), the maximum temperature is derated linearly by 1°C every 1000 ft. Drive case temperature should be measured at the location indicated in [Figure 4](#).

Operating (drive case temperature)	0° to 75°C (32° to 167°F)
Nonoperating (ambient)	-40° to 70°C (-40° to 158°F)

2.9.2 Temperature gradient

Operating	20°C per hour (68°F per hour max), without condensation
Nonoperating	30°C per hour (86°F per hour max)

2.9.3 Humidity

2.9.3.1 Relative humidity

Operating	5% to 95% noncondensing (30% per hour max)
Nonoperating	5% to 95% noncondensing (30% per hour max)

2.9.3.2 Wet bulb temperature

Operating	37.7°C (99.9°F max)
Nonoperating	40°C (104°F max)

2.9.4 Altitude

Operating	-60.96m to 3048m (-200 ft. to 10,000+ ft.)
Nonoperating	-60.96m to 12,192m (-200 ft. to 40,000+ ft.)

2.9.5 Shock

All shock specifications assume that the drive is mounted securely with the input shock applied at the drive mounting screws. Shock may be applied in the X, Y or Z axis.

2.9.5.1 Operating shock

These drives comply with the performance levels specified in this document when subjected to a maximum operating shock of 80 Gs based on half-sine shock pulses of 2ms during read operations. Shocks should not be repeated more than two times per second.

2.9.5.2 Nonoperating shock

The nonoperating shock level that the drive can experience without incurring physical damage or degradation in performance when subsequently put into operation is 300 Gs (for 3TB and 2TB model) and 350 Gs (for 1TB) based on a nonrepetitive half-sine shock pulse of 2ms duration.

2.9.6 Vibration

All vibration specifications assume that the drive is mounted securely with the input vibration applied at the drive mounting screws. Vibration may be applied in the X, Y or Z axis, with linear swept sine inputs.

2.9.6.1 Operating vibration

The maximum vibration levels that the drive may experience while meeting the performance standards specified in this document are specified below.

2Hz to 22Hz	0.25 Gs (Limited displacement)
22Hz to 350Hz	0.50 Gs
350Hz to 500Hz	0.25 Gs

2.9.6.2 Nonoperating vibration

The maximum nonoperating vibration levels that the drive may experience without incurring physical damage or degradation in performance when subsequently put into operation are specified below.

5Hz to 22Hz	3.0 Gs (limited displacement)
22Hz to 350Hz	3.0 Gs
35Hz to 500Hz	3.0 Gs

2.10 Acoustics

Drive acoustics are measured as overall A-weighted acoustic sound power levels (no pure tones). All measurements are consistent with ISO document 7779. Sound power measurements are taken under essentially free-field conditions over a reflecting plane. For all tests, the drive is oriented with the cover facing upward.

Note	For seek mode tests, the drive is placed in seek mode only. The number of seeks per second is defined by the following equation: (Number of seeks per second = 0.4 / (average latency + average access time))
-------------	--

Table 5 Fluid Dynamic Bearing (FDB) motor acoustics

Model	Idle*	Seek
ST3000VM002 ST2000VM003	2.1 bels (typ) 2.3 bels (max)	2.3 bels (typ) 2.4 bels (max)
ST1000VM002	1.9 bels (typ) 2.1 bels (max)	2.2 bels (typ) 2.3 bels (max)

*During periods of drive idle, some offline activity may occur according to the S.M.A.R.T. specification, which may increase acoustic and power to operational levels.

2.10.1 Test for Prominent Discrete Tones (PDTs)

Seagate follows the ECMA-74 standards for measurement and identification of PDTs. An exception to this process is the use of the absolute threshold of hearing. Seagate uses this threshold curve (originated in ISO 389-7) to discern tone audibility and to compensate for the inaudible components of sound prior to computation of tone ratios according to Annex D of the ECMA-74 standards.

2.11 Electromagnetic immunity

When properly installed in a representative host system, the drive operates without errors or degradation in performance when subjected to the radio frequency (RF) environments defined in the following table:

Table 6 Radio frequency environments

Test	Description	Performance Level	Reference standard
Electrostatic discharge	Contact, HCP, VCP: ± 4 kV; Air: ± 8 kV	B	EN61000-4-2: 95
Radiated RF immunity	80MHz to 1,000MHz, 3 V/m, 80% AM with 1kHz sine 900MHz, 3 V/m, 50% pulse modulation @ 200Hz	A	EN61000-4-3: 96 ENV 50204: 95
Electrical fast transient	± 1 kV on AC mains, ± 0.5 kV on external I/O	B	EN61000-4-4: 95
Surge immunity	± 1 kV differential, ± 2 kV common, AC mains	B	EN61000-4-5: 95
Conducted RF immunity	150kHz to 80MHz, 3 Vrms, 80% AM with 1kHz sine	A	EN61000-4-6: 97
Voltage dips, interrupts	0% open, 5 seconds 0% short, 5 seconds 40%, 0.10 seconds 70%, 0.01 seconds	C C C B	EN61000-4-11: 94

2.12 Reliability - Annualized Failure Rate

The product will achieve an Annualized Failure Rate (AFR) of 0.55% when operated in an environment of ambient air temperatures of 25°C. Operation at temperatures outside the specifications shown in [Section 2.9](#) may increase the product AFR. AFR is a population statistics that is not relevant to individual units.

- AFR specifications are based on the following assumptions for consumer electronics environments:
- 8760 power-on-hours per year
- 10,000 average motor start/stop cycles per year
- Operations at nominal voltages
- Temperatures outside the specifications in [Section 2.9](#) may reduce the product reliability.
- Normal I/O duty cycle for consumer electronics environments. Operation at excessive I/O duty cycle may degrade product reliability.

The consumer electronics environment of power-on-hours, temperature, and I/O duty cycle affect the product AFR. The AFR will be degraded if used in an enterprise application.

2.13 Warranty

To determine the warranty for a specific drive, use a web browser to access the following web page:

<http://www.seagate.com/support/warranty-and-replacements/>

From this page, click on “Check to see if the drive is under Warranty”. Users will be asked to provide the drive serial number, model number (or part number) and country of purchase. The system will display the warranty information for the drive.

2.14 Agency certification

2.14.1 Safety certification

These products are certified to meet the requirements of UL60950-1, CSA60950-1 and EN60950 and so marked as to the certify agency.

2.14.2 Electromagnetic compatibility

Hard drives that display the CE mark comply with the European Union (EU) requirements specified in the Electromagnetic Compatibility Directive (2004/108/EC) as put into place 20 July 2007. Testing is performed to the levels specified by the product standards for Information Technology Equipment (ITE). Emission levels are defined by EN55022, Class B and the immunity levels are defined by EN55024.

Drives are tested in representative end-user systems. Although CE-marked Seagate drives comply with the directives when used in the test systems, we cannot guarantee that all systems will comply with the directives. The drive is designed for operation inside a properly designed enclosure, with properly shielded I/O cable (if necessary) and terminators on all unused I/O ports. Computer manufacturers and system integrators should confirm EMC compliance and provide CE marking for their products.

Korean RRL

If these drives have the Korean Communications Commission (KCC) logo, they comply with paragraph 1 of Article 11 of the Electromagnetic Compatibility control Regulation and meet the Electromagnetic Compatibility (EMC) Framework requirements of the Radio Research Laboratory (RRL) Communications Commission, Republic of Korea.

These drives have been tested and comply with the Electromagnetic Interference/Electromagnetic Susceptibility (EMI/EMS) for Class B products. Drives are tested in a representative, end-user system by a Korean-recognized lab.

- Family name: Video 3.5 HDD
- Certificate number: KCC-REM-STX-Video35HDD
- Certificate date: 12 March 2013

Australian C-Tick (N176)

If these models have the C-Tick marking, they comply with the Australia/New Zealand Standard AS/NZ CISPR22 and meet the Electromagnetic Compatibility (EMC) Framework requirements of the Australian Communication Authority (ACA).

2.14.3 FCC verification

These drives are intended to be contained solely within a personal computer or similar enclosure (not attached as an external device). As such, each drive is considered to be a subassembly even when it is individually marketed to the customer. As a subassembly, no Federal Communications Commission verification or certification of the device is required.

Seagate has tested this device in enclosures as described above to ensure that the total assembly (enclosure, disk drive, motherboard, power supply, etc.) does comply with the limits for a Class B computing device, pursuant to Subpart J, Part 15 of the FCC rules. Operation with noncertified assemblies is likely to result in interference to radio and television reception.

Radio and television interference. This equipment generates and uses radio frequency energy and if not installed and used in strict accordance with the manufacturer's instructions, may cause interference to radio and television reception.

This equipment is designed to provide reasonable protection against such interference in a residential installation. However, there is no guarantee that interference will not occur in a particular installation. If this equipment does cause interference to radio or television, which can be determined by turning the equipment on and off, users are encouraged to try one or more of the following corrective measures:

- Reorient the receiving antenna.
- Move the device to one side or the other of the radio or TV.
- Move the device farther away from the radio or TV.
- Plug the computer into a different outlet so that the receiver and computer are on different branch outlets.

If necessary, users should consult the dealer or an experienced radio/television technician for additional suggestions. Users may find helpful the following booklet prepared by the Federal Communications Commission: *How to Identify and Resolve Radio-Television Interference Problems*. This booklet is available from the Superintendent of Documents, U.S. Government Printing Office, Washington, DC 20402. Refer to publication number 004-000-00345-4.

2.15 Environmental protection

Seagate designs its products to meet environmental protection requirements worldwide, including regulations restricting certain chemical substances.

2.15.1 European Union Restriction of Hazardous Substances (RoHS) Directive

The European Union Restriction of Hazardous Substances (RoHS) Directive, restricts the presence of chemical substances, including Lead, Cadmium, Mercury, Hexavalent Chromium, PBB and PBDE, in electronic products, effective July 2006. This drive is manufactured with components and materials that comply with the RoHS Directive.

2.15.2 China Restriction of Hazardous Substances (RoHS) Directive 中国限制危险物品的指令

This product has an Environmental Protection Use Period (EPUP) of 20 years. The following table contains information mandated by China's "Marking Requirements for Control of Pollution Caused by Electronic Information Products" Standard.



该产品具有20年的环境保护使用周期（EPUP）。下表包含了中国“电子产品所导致的污染的控制的记号要求”所指定的信息。

Name of Parts 部件名称	Toxic or Hazardous Substances or Elements有毒有害物质或元素					
	Lead 铅 (Pb)	Mercury 汞 (Hg)	Cadmium 镉 (Cd)	Hexavalent Chromium 六价铬 (Cr6+)	Polybrominated Diphenyl 多溴联苯 (PBB)	Polybrominated Diphenyl Ether 多溴二苯醚 (PBDE)
PCBA	X	O	O	O	O	O
HDA	X	O	O	O	O	O

"O" indicates the hazardous and toxic substance content of the part (at the homogenous material level) is lower than the threshold defined by the China RoHS MCV Standard.

“O”表示该部件（于同类物品程度上）所含的危险和有毒物质低于中国RoHS MCV标准所定义的门槛值。

"X" indicates the hazardous and toxic substance content of the part (at the homogenous material level) is over the threshold defined by the China RoHS MCV Standard.

“X”表示该部件（于同类物品程度上）所含的危险和有毒物质超出中国RoHS MCV标准所定义的门槛值。

2.16 Corrosive environment

Seagate electronic drive components pass accelerated corrosion testing equivalent to 10 years exposure to light industrial environments containing sulfurous gases, chlorine and nitric oxide, classes G and H per ASTM B845. However, this accelerated testing cannot duplicate every potential application environment. Users should use caution exposing any electronic components to uncontrolled chemical pollutants and corrosive chemicals as electronic drive component reliability can be affected by the installation environment. The silver, copper, nickel and gold films used in Seagate products are especially sensitive to the presence of sulfide, chloride, and nitrate contaminants. Sulfur is found to be the most damaging. In addition, electronic components should never be exposed to condensing water on the surface of the printed circuit board assembly (PCBA) or exposed to an ambient relative humidity greater than 95%. Materials used in cabinet fabrication, such as vulcanized rubber, that can outgas corrosive compounds should be minimized or eliminated. The useful life of any electronic equipment may be extended by replacing materials near circuitry with sulfide-free alternatives.

3.0 Configuring and Mounting the Drive

This section contains the specifications and instructions for configuring and mounting the drive.

3.1 Handling and static-discharge precautions

After unpacking, and before installation, the drive may be exposed to potential handling and electrostatic discharge (ESD) hazards. Observe the following standard handling and static-discharge precautions:

Caution:

- Before handling the drive, put on a grounded wrist strap, or ground yourself frequently by touching the metal chassis of a computer that is plugged into a grounded outlet. Wear a grounded wrist strap throughout the entire installation procedure.
- Handle the drive by its edges or frame *only*.
- The drive is extremely fragile—handle it with care. Do not press down on the drive top cover.
- Always rest the drive on a padded, antistatic surface until mounting it in the computer.
- Do not touch the connector pins or the printed circuit board.
- Do not remove the factory-installed labels from the drive or cover them with additional labels. Removal voids the warranty. Some factory-installed labels contain information needed to service the drive. Other labels are used to seal out dirt and contamination.

3.2 Configuring the drive

Each drive on the Serial ATA interface connects point-to-point with the Serial ATA host adapter. There is no master/slave relationship because each drive is considered a master in a point-to-point relationship. If two drives are attached on one Serial ATA host adapter, the host operating system views the two devices as if they were both “masters” on two separate ports. Both drives behave as if they are Device 0 (master) devices.

Serial ATA drives are designed for easy installation. It is usually not necessary to set any jumpers on the drive for proper operation; however, if users connect the drive and receive a “drive not detected” error, the SATA-equipped motherboard or host adapter may use a chipset that does not support SATA speed autonegotiation.

3.3 Serial ATA cables and connectors

The Serial ATA interface cable consists of four conductors in two differential pairs, plus three ground connections. The cable size may be 30 to 26 AWG with a maximum length of one meter (39.37 in). See [Table 7](#) for connector pin definitions. Either end of the SATA signal cable can be attached to the drive or host.

For direct backplane connection, the drive connectors are inserted directly into the host receptacle. The drive and the host receptacle incorporate features that enable the direct connection to be hot pluggable and blind mateable.

For installations which require cables, users can connect the drive as illustrated in [Figure 3](#).

Figure 3 Attaching SATA cabling

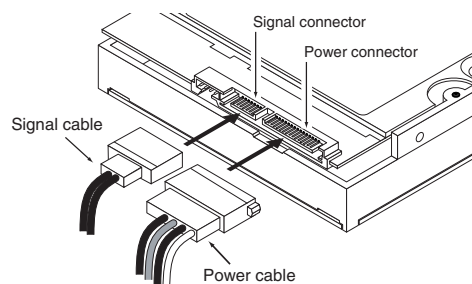

Each cable is keyed to ensure correct orientation. Video 3.5 HDD drives support latching SATA connectors.

3.4 Drive mounting

Users can mount the drive in any orientation using four screws in the side-mounting holes or four screws in the bottom-mounting holes. See **Figure 4** for drive mounting dimensions. Follow these important mounting precautions when mounting the drive:

- Allow a minimum clearance of 0.030 in (0.76mm) around the entire perimeter of the drive for cooling.
- Use only 6-32 UNC mounting screws.
- The screws should be inserted no more than 0.150 in (3.81mm) into the bottom or side mounting holes.
- Do not overtighten the mounting screws (maximum torque: 6 in per lb).

Figure 4 Mounting dimensions (3TB and 2TB model)

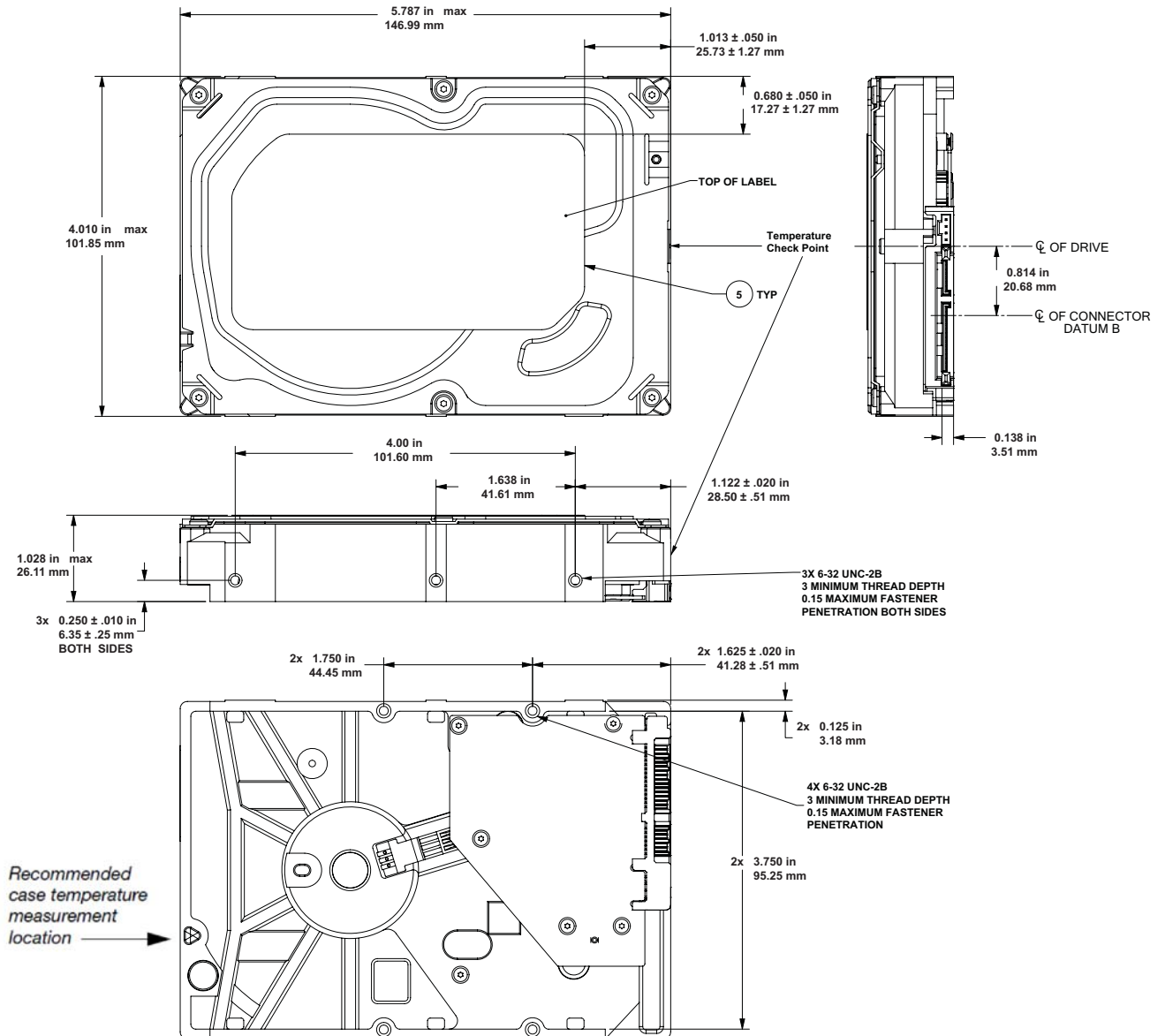

Note. Image is for reference only, and may not represent actual drive.

Figure 5 Mounting dimensions (1TB model)

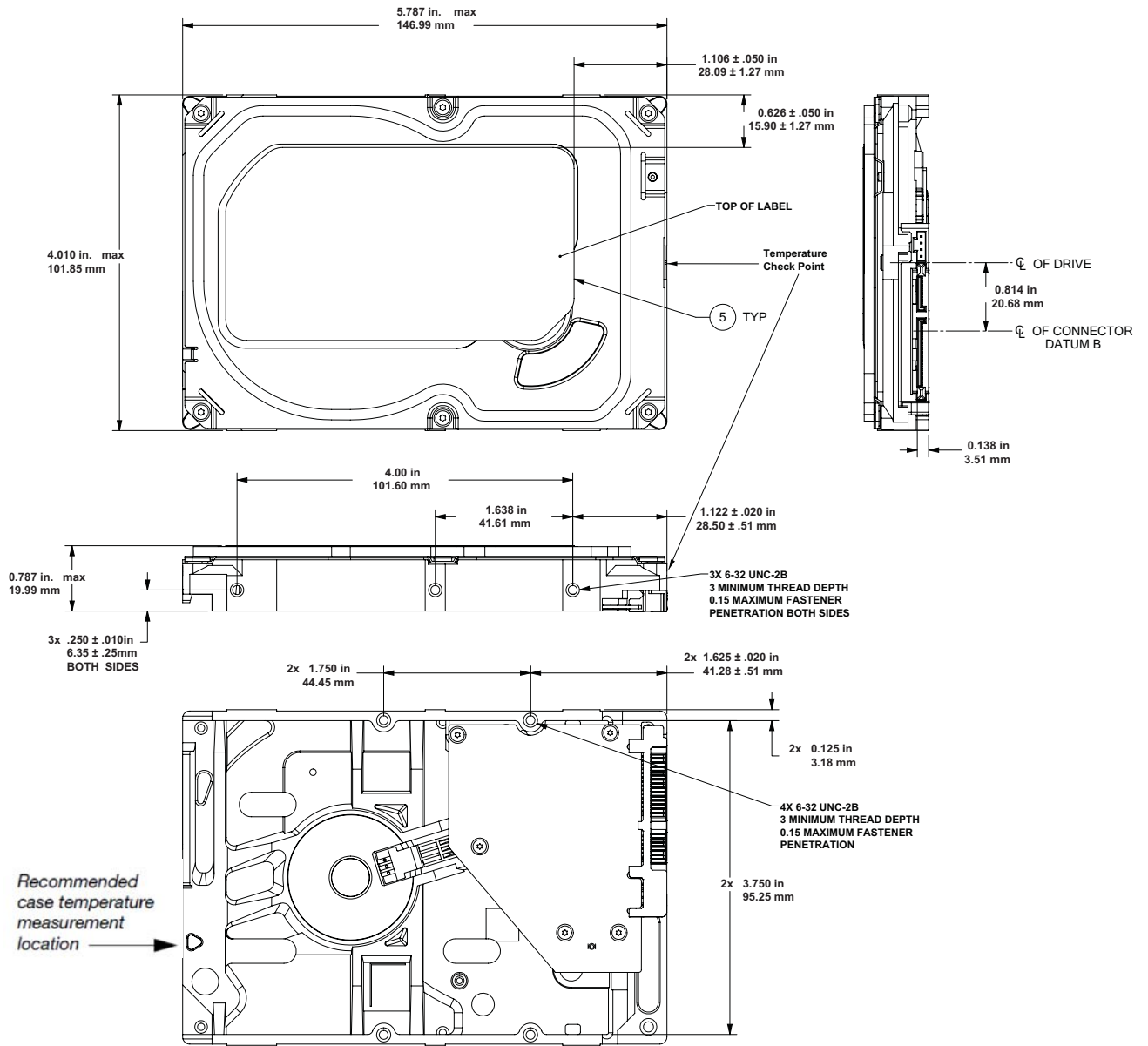

Note. Image is for reference only, and may not represent actual drive.

4.0 Serial ATA Interface

These drives use the industry-standard Serial ATA (SATA) interface that supports FIS data transfers. It supports ATA programmed input/output (PIO) modes 0 to 4; multiword DMA modes 0 to 2, and Ultra DMA modes 0 to 6.

For detailed information about the Serial ATA interface, refer to the “Serial ATA: High Speed Serialized AT Attachment” specification.

4.1 Hot-Plug compatibility

Video 3.5 HDD drives incorporate connectors which enable users to hot plug these drives in accordance with the Serial ATA Revision 2.5 specification. This specification can be downloaded from www.serialata.org.

4.2 Serial ATA device plug connector pin definitions

Table 7 summarizes the signals on the Serial ATA interface and power connectors.

Table 7 Serial ATA connector pin definitions

Segment	Pin	Function	Definition
Signal	S1	Ground	2nd mate
	S2	A+	Differential signal pair A from PHY
	S3	A-	
	S4	Ground	2nd mate
	S5	B-	Differential signal pair B from PHY
	S6	B+	
	S7	Ground	2nd mate
Key and spacing separate signal and power segments			
Power	P1	V ₃₃	3.3V power
	P2	V ₃₃	3.3V power
	P3	V ₃₃	3.3V power, pre-charge, 2nd mate
	P4	Ground	1st mate
	P5	Ground	2nd mate
	P6	Ground	2nd mate
	P7	V ₅	5V power, pre-charge, 2nd mate
	P8	V ₅	5V power
	P9	V ₅	5V power
	P10	Ground	2nd mate
	P11	Ground or LED signal	If grounded, drive does not use deferred spin
	P12	Ground	1st mate.
	P13	V ₁₂	12V power, pre-charge, 2nd mate
	P14	V ₁₂	12V power
	P15	V ₁₂	12V power

Notes:

- All pins are in a single row, with a 1.27mm (0.050”) pitch.
- The comments on the mating sequence apply to the case of backplane blindmate connector only. In this case, the mating sequences are:
 - the ground pins P4 and P12.

- the pre-charge power pins and the other ground pins.
 - the signal pins and the rest of the power pins.
3. There are three power pins for each voltage. One pin from each voltage is used for pre-charge when installed in a blind-mate backplane configuration.
 4. All used voltage pins (V_x) must be terminated.

4.3 Supported ATA commands

The following table lists Serial ATA standard commands that the drive supports. For a detailed description of the ATA commands, refer to the Serial ATA International Organization: Serial ATA Revision 3.0 (<http://www.sata-io.org>).

See “S.M.A.R.T. commands” on page 33 for details and subcommands used in the S.M.A.R.T. implementation.

Table 8 Supported ATA commands

Command name	Command code (in hex)
Check Power Mode	E5 _H
Configure Stream	51 _H
Device Configuration Freeze Lock	B1 _H / C1 _H
Device Configuration Identify	B1 _H / C2 _H
Device Configuration Restore	B1 _H / C0 _H
Device Configuration Set	B1 _H / C3 _H
Device Reset	08 _H
Download Microcode	92 _H
Execute Device Diagnostics	90 _H
Flush Cache	E7 _H
Flush Cache Extended	EA _H
Format Track	50 _H
Identify Device	EC _H
Idle	E3 _H
Idle Immediate	E1 _H
Initialize Device Parameters	91 _H
Read Buffer	E4 _H
Read DMA	C8 _H
Read DMA Extended	25 _H
Read DMA Without Retries	C9 _H
Read FPDMA Queued	60 _H
Read Log Ext	2F _H
Read Multiple	C4 _H
Read Multiple Extended	29 _H
Read Native Max Address	F8 _H

Table 8 Supported ATA commands (Continued)

Command name	Command code (in hex)
Read Native Max Address Extended	27 _H
Read Sectors	20 _H
Read Stream DMA Extended	2A _H
Read Stream Extended	2B _H
Read Sectors Extended	24 _H
Read Sectors Without Retries	21 _H
Read Verify Sectors	40 _H
Read Verify Sectors Extended	42 _H
Read Verify Sectors Without Retries	41 _H
Recalibrate	10 _H
Security Disable Password	F6 _H
Security Erase Prepare	F3 _H
Security Erase Unit	F4 _H
Security Freeze	F5 _H
Security Set Password	F1 _H
Security Unlock	F2 _H
Seek	70 _H
Set Features	EF _H
Set Max Address Note: Individual Set Max Address commands are identified by the value placed in the Set Max Features register as defined to the right.	F9 _H Address: 00 _H Password: 01 _H Lock: 02 _H Unlock: 03 _H Freeze Lock: 04 _H
Set Max Address Extended	37 _H
Set Multiple Mode	C6 _H
Sleep	E6 _H
S.M.A.R.T. Disable Operations	B0 _H / D9 _H
S.M.A.R.T. Enable/Disable Autosave	B0 _H / D2 _H
S.M.A.R.T. Enable Operations	B0 _H / D8 _H
S.M.A.R.T. Execute Offline	B0 _H / D4 _H
S.M.A.R.T. Read Attribute Thresholds	B0 _H / D1 _H
S.M.A.R.T. Read Data	B0 _H / D0 _H
S.M.A.R.T. Read Log Sector	B0 _H / D5 _H
S.M.A.R.T. Return Status	B0 _H / DA _H

Table 8 Supported ATA commands (Continued)

Command name	Command code (in hex)
S.M.A.R.T. Save Attribute Values	B0 _H / D3 _H
S.M.A.R.T. Write Log Sector	B0 _H / D6 _H
Standby	E2 _H
Standby Immediate	E0 _H
Write Buffer	E8 _H
Write DMA	CA _H
Write DMA Extended	35 _H
Write DMA FUA Extended	3D _H
Write DMA Without Retries	CB _H
Write FPDMA Queued	61 _H
Write Log Extended	3F _H
Write Multiple	C5 _H
Write Multiple Extended	39 _H
Write Multiple FUA Extended	CE _H
Write Sectors	30 _H
Write Sectors Without Retries	31 _H
Write Sectors Extended	34 _H
Write Stream DMA Extended	3A _H
Write Stream Extended	3B _H
Write Uncorrectable	45 _H

4.3.1 Identify Device command

The Identify Device command (command code EC_H) transfers information about the drive to the host following power up. The data is organized as a single 4096-byte block of data, whose contents are shown on page 25. All reserved bits or words should be set to zero. Parameters listed with an “x” are drive-specific or vary with the state of the drive.

The following commands contain drive-specific features that may not be included in the Serial ATA specification.

Table 9 Identify Device commands

Word	Description	Value
0	Configuration information: <ul style="list-style-type: none"> • Bit 15: 0 = ATA; 1 = ATAPI • Bit 7: removable media • Bit 6: removable controller • Bit 0: reserved 	0C5A _H
1	Number of logical cylinders	16,383
2	ATA-reserved	C837 _H
3	Number of logical heads	16
4	Retired	0000 _H
5	Retired	0000 _H
6	Number of logical sectors per logical track: 63	003F _H
7–9	Retired	0000 _H
10–19	Serial number: (20 ASCII characters, 0000 _H = none)	ASCII
20	Retired	0000 _H
21	Retired	0000 _H
22	Obsolete	0000 _H
23–26	Firmware revision (8 ASCII character string, padded with blanks to end of string)	x.xx
27–46	Drive model number: (40 ASCII characters, padded with blanks to end of string)	
47	(Bits 7–0) Maximum sectors per interrupt on Read multiple and Write multiple (16)	8010 _H
48	Reserved	0000 _H
49	Standard Standby timer, IORDY supported and may be disabled	2F00 _H
50	ATA-reserved	4000 _H
51	PIO data-transfer cycle timing mode	0200 _H
52	Retired	0200 _H
53	Words 54–58, 64–70 and 88 are valid	0007 _H
54	Number of current logical cylinders	xxxx _H
55	Number of current logical heads	xxxx _H
56	Number of current logical sectors per logical track	xxxx _H

Table 9 Identify Device commands (Continued)

Word	Description	Value
57–58	Current capacity in sectors	xxxx _H
59	Number of sectors transferred during a Read Multiple or Write Multiple command	xxxx _H
60–61	Total number of user-addressable LBA sectors available (see Section 2.2 for related information) *Note: The maximum value allowed in this field is: 0FFFFFFFh (268,435,455 sectors, 137 Gbytes). Drives with capacities over 137 Gbytes will have 0FFFFFFFh in this field and the actual number of user-addressable LBAs specified in words 100-103. This is required for drives that support the 48-bit addressing feature.	0FFFFFFFh*
62	Retired	0000 _H
63	Multiword DMA active and modes supported (see note following this table)	xx07 _H
64	Advanced PIO modes supported (modes 3 and 4 supported)	0003 _H
65	Minimum multiword DMA transfer cycle time per word (120 nsec)	0078 _H
66	Recommended multiword DMA transfer cycle time per word (120 nsec)	0078 _H
67	Minimum PIO cycle time without IORDY flow control (240 nsec)	0078 _H
68	Minimum PIO cycle time with IORDY flow control (120 nsec)	0078 _H
69–74	ATA-reserved	0000 _H
75	Queue depth	001F _H
76	Serial ATA capabilities	xxxx _H
77	Reserved for future Serial ATA definition	xxxx _H
78	Serial ATA features supported	xxxx _H
79	Serial ATA features enabled	xxxx _H
80	Major version number	01F0 _H
81	Minor version number	0028 _H
82	Command sets supported	346B _H
83	Command sets supported	7D69 _H
84	Command sets support extension (see note following this table)	4133 _H See Word 108-111 note. (4133 _H = 1000000100101 binary)
85	Command sets enabled	34xx _H
86	Command sets enabled	BE01 _H
87	Command sets enable extension	4133 _H
88	Ultra DMA support and current mode (see note following this table)	00A4 _H
89	Security erase time	00A4 _H

Table 9 Identify Device commands (Continued)

Word	Description	Value
90	Enhanced security erase time	00A9 _H
92	Master password revision code	FFFE _H
93	Hardware reset value	xxxx _H
95	Stream Min. Request Size	0000 _H
96	Streaming Transfer Time - DMA	0000 _H
97	Streaming Access Latency- DMA and PIO	0000 _H
98-99	Streaming Performance Granularity	2710 _H / 0000 _H
100-103	Total number of user-addressable LBA sectors available (see Section 2.2 for related information). These words are required for drives that support the 48-bit addressing feature. Maximum value: 0000FFFFFFFF _H .	ST3000VM002 = 5,860,533,168 ST2000VM003 = 3,907,029,168 ST1000VM002 = 1,953,525,168
104	Streaming Transfer Time - PIO	0000 _H
105-107	ATA-reserved	0000 _H
108-111	The mandatory value of the world wide name (WWN) for the drive. NOTE: This field is valid if word 84, bit 8 is set to 1 indicating 64-bit WWN support.	Each drive will have a unique value.
112-127	ATA-reserved	0000 _H
128	Security status	0001 _H
129-159	Seagate-reserved	xxxx _H
160-254	ATA-reserved	0000 _H
255	Integrity word	xxA5 _H

Note Automatic Acoustic Management (AAM) features are not supported.

Note See the bit descriptions below for words 63, 84, and 88 of the Identify Drive data.

Table 10 Bit Descriptions

Description (if bit is set to 1)		
Bit	Word 63	
0	Multiword DMA mode 0 is supported.	
1	Multiword DMA mode 1 is supported.	
2	Multiword DMA mode 2 is supported.	
8	Multiword DMA mode 0 is currently active.	
9	Multiword DMA mode 1 is currently active.	
10	Multiword DMA mode 2 is currently active.	

Table 10 Bit Descriptions (Continued)

Bit	Word 84
0	SMART error login is supported.
1	SMART self-test is supported.
2	Media serial number is supported.
3	Media Card Pass Through Command feature set is supported.
4	Streaming feature set is supported.
5	GPL feature set is supported.
6	WRITE DMA FUA EXT and WRITE MULTIPLE FUA EXT commands are supported.
7	WRITE DMA QUEUED FUA EXT command is supported.
8	64-bit World Wide Name is supported.
9-10	Obsolete.
11-12	Reserved for TLC.
13	IDLE IMMEDIATE command with IUNLOAD feature is supported.
14	Shall be set to 1.
15	Shall be cleared to 0.
Bit	Word 88
0	Ultra DMA mode 0 is supported.
1	Ultra DMA mode 1 is supported.
2	Ultra DMA mode 2 is supported.
3	Ultra DMA mode 3 is supported.
4	Ultra DMA mode 4 is supported.
5	Ultra DMA mode 5 is supported.
6	Ultra DMA mode 6 is supported.
8	Ultra DMA mode 0 is currently active.
9	Ultra DMA mode 1 is currently active.
10	Ultra DMA mode 2 is currently active.
11	Ultra DMA mode 3 is currently active.
12	Ultra DMA mode 4 is currently active.
13	Ultra DMA mode 5 is currently active.
14	Ultra DMA mode 6 is currently active.

4.3.2 Set Features command

This command controls the implementation of various features that the drive supports. When the drive receives this command, it sets BSY, checks the contents of the Features register, clears BSY and generates an interrupt. If the value in the register does not represent a feature that the drive supports, the command is aborted. Power-on default has the read look-ahead and write caching features enabled. The acceptable values for the Features register are defined as follows:

Table 11 Set Features command values

02 _H	Enable write cache (<i>default</i>).
03 _H	Set transfer mode (based on value in Sector Count register). Sector Count register values:
	00 _H Set PIO mode to default (PIO mode 2).
	01 _H Set PIO mode to default and disable IORDY (PIO mode 2).
	08 _H PIO mode 0
	09 _H PIO mode 1
	0A _H PIO mode 2
	0B _H PIO mode 3
	0C _H PIO mode 4 (<i>default</i>)
	20 _H Multiword DMA mode 0
	21 _H Multiword DMA mode 1
	22 _H Multiword DMA mode 2
	40 _H Ultra DMA mode 0
	41 _H Ultra DMA mode 1
	42 _H Ultra DMA mode 2
	43 _H Ultra DMA mode 3
	44 _H Ultra DMA mode 4
	45 _H Ultra DMA mode 5
	46 _H Ultra DMA mode 6
06 _H	Enable the PUIS feature set,
07 _H	07H PUIS feature set device spin-up
10 _H	Enable use of SATA features
55 _H	Disable read look-ahead (read cache) feature.
82 _H	Disable write cache.
86 _H	Disable the PUIS feature set.
90 _H	Disable use of SATA features.
AA _H	Enable read look-ahead (read cache) feature (<i>default</i>).
F1 _H	Report full capacity available.

Note

At power-on, or after a hardware or software reset, the default values of the features are as indicated above.

4.3.3 S.M.A.R.T. commands

S.M.A.R.T. provides near-term failure prediction for disk drives. When S.M.A.R.T. is enabled, the drive monitors predetermined drive attributes that are susceptible to degradation over time. If self-monitoring determines that a failure is likely, S.M.A.R.T. makes a status report available to the host. Not all failures are predictable. S.M.A.R.T. predictability is limited to the attributes the drive can monitor. For more information on S.M.A.R.T. commands and implementation, see the *Draft ATA-5 Standard*.

SeaTools diagnostic software activates a built-in drive self-test (DST S.M.A.R.T. command for D4_H) that eliminates unnecessary drive returns. The diagnostic software ships with all new drives and is also available at: <http://seatools.seagate.com>.

This drive is shipped with S.M.A.R.T. features disabled. Users must have a recent BIOS or software package that supports S.M.A.R.T. to enable this feature. The table below shows the S.M.A.R.T. command codes that the drive uses.

Table 12 S.M.A.R.T. commands

Code in features register	S.M.A.R.T. command
D0 _H	S.M.A.R.T. Read Data
D2 _H	S.M.A.R.T. Enable/Disable Attribute Autosave
D3 _H	S.M.A.R.T. Save Attribute Values
D4 _H	S.M.A.R.T. Execute Off-line Immediate (runs DST)
D5 _H	S.M.A.R.T. Read Log Sector
D6 _H	S.M.A.R.T. Write Log Sector
D8 _H	S.M.A.R.T. Enable Operations
D9 _H	S.M.A.R.T. Disable Operations
DA _H	S.M.A.R.T. Return Status

Note	If an appropriate code is not written to the Features Register, the command is aborted and 0x04 (abort) is written to the Error register.
-------------	---



Seagate Technology LLC

AMERICAS Seagate Technology LLC 10200 South De Anza Boulevard, Cupertino, California 95014, United States, 408-658-1000

ASIA/PACIFIC Seagate Singapore International Headquarters Pte. Ltd. 7000 Ang Mo Kio Avenue 5, Singapore 569877, 65-6485-3888

EUROPE, MIDDLE EAST AND AFRICA Seagate Technology SAS 16-18 rue du Dôme, 92100 Boulogne-Billancourt, France, 33 1-4186 10 00

Publication Number: 100633414, Rev. M

May 2015

Ovaj dokument je originalno proizveden i objavljen od strane proizvođača, brenda Seagate, i preuzet je sa njihove zvanične stranice. S obzirom na ovu činjenicu, Tehnoteka ističe da ne preuzima odgovornost za tačnost, celovitost ili pouzdanost informacija, podataka, mišljenja, saveta ili izjava sadržanih u ovom dokumentu.

Napominjemo da Tehnoteka nema ovlašćenje da izvrši bilo kakve izmene ili dopune na ovom dokumentu, stoga nismo odgovorni za eventualne greške, propuste ili netačnosti koje se mogu naći unutar njega. Tehnoteka ne odgovara za štetu nanесenu korisnicima pri upotrebi netačnih podataka. Ukoliko imate dodatna pitanja o proizvodu, ljubazno vas molimo da kontaktirate direktno proizvođača kako biste dobili sve detaljne informacije.

Za najnovije informacije o ceni, dostupnim akcijama i tehničkim karakteristikama proizvoda koji se pominje u ovom dokumentu, molimo posetite našu stranicu klikom na sledeći link:

<https://tehnoteka.rs/p/seagate-hard-disk-2tb-st2000vm003-akcija-cena/>