

Uputstvo za upotrebu (EN)

THERMALTAKE kućište S500 belo



Tehnoteka je online destinacija za upoređivanje cena i karakteristika bele tehnike, potrošačke elektronike i IT uređaja kod trgovinskih lanaca i internet prodavnica u Srbiji. Naša stranica vam omogućava da istražite najnovije informacije, detaljne karakteristike i konkurentne cene proizvoda.

Posetite nas i uživajte u ekskluzivnom iskustvu pametne kupovine klikom na link:

<https://tehnoteka.rs/p/thermaltake-kuciste-s500-belo-akcija-cena/>

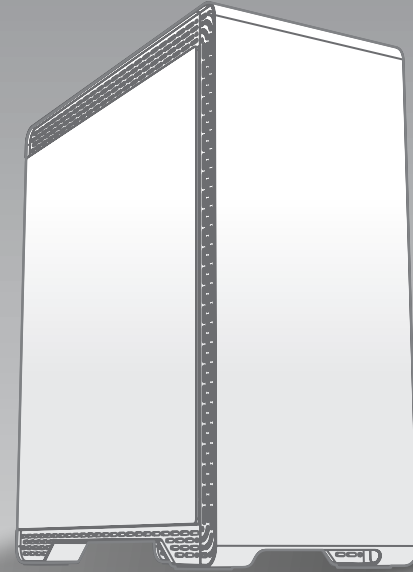

Picture is for reference only

S500 TG

User's Manual
Benutzerhandbuch
Mode d'emploi
Manual del usuario
Manuale dell'utente
Manual do Utilizador

安裝說明書
用戶手冊
ユーザーズマニュアル
Руководство пользователя
kullanıcı elkitabı
(EEE Yönetmeliğine Uygundur)
คู่มือการไอซ์



© 2019 Thermaltake Technology Co., Ltd. All Rights Reserved. 2018.04
All other registered trademarks belong to their respective companies. www.thermaltake.com



TT Premium



TT Premium

To continue achieving the corporate mission of delivering the perfect user experience, Thermaltake developed "TT Premium" with the essence of combining supreme quality products with a new logo design. TT Premium is far more than just a guarantee of quality. Behind the name, it represents the passion in DIY, Modding and Thermaltake's desire to be the most innovative brand in the PC hardware market. To satisfy the demand of the high-end PC users, TT Premium follows its core values of Excellent Quality, Unique Design, Diverse Combinations and Boundless Creativity to provide a high performance PC product for every enthusiast. <http://tppremium.com>

Tt LCS-Liquid Cooling Support Certification



Tt LCS Certified is a Thermaltake exclusive certification applied to only products that pass the design and hardcore enthusiasts standards that a true LCS chassis should be held to. The Tt LCS certification was created so that we at Thermaltake can designate to all power users which chassis have been tested to be best compatible with extreme liquid cooling configurations to ensure you get the best performance from the best features and fitment.

Join Tt Community To Receive Benefits



Dear Valued Customer,

Thank you for choosing Thermaltake.

As a new user we value your thoughts and opinions and your feedback is important to us. We at Thermaltake would like to use this opportunity to invite you to join our Community Forums. Register today to start enjoying the full benefits of our community.



Benefits of being a member:

- Quick and responsive user support
- Receive help and advice with new builds
- Keep up to date with new product releases
- Share your thoughts and builds with the community
- Enter monthly contests and giveaways

Brand official website
<http://www.thermaltake.com/>

Global Facebook
<https://www.facebook.com/ThermaltakeInc>

Taiwan Facebook
<http://www.facebook.com/ThermaltakeTW>

Global community forums
<http://community.thermaltake.com>

CONTENTS

Chapter 1. Product Introduction

1.0	Specification	01
1.1	Accessory	02
1.2	Warning and Notice	03

Chapter 2. Installation Guide

2.0	Side Panels Disassembly	05
2.1	Power Supply Unit (PSU) Installation	06
2.2	Motherboard Installation	07
2.3	3.5" & 2.5" HDD Installation	08
2.4	PCI Card Installation	09
2.5	Air Cooling Installation	11
2.6	Liquid Cooling Installation	12
2.7	Max Radiator Installation Notice	13
2.8	Pump Installation	14

Chapter 3. Leads Installation

3.1	Case LED Connection	15
3.2	USB 3.0 Connection	15
3.3	Audio Connection	15

Chapter 4. Other

4.1	Thermaltake Power Supply Series (Optional)	21
4.2	Tt RGB Plus Ecosystem	22

*Picture for reference only

*Information in the user manual is subject to change without notice

Specification

Model	S500 TG
Case Type	Mid Tower
Dimension (H*W*D)	565 x 240 x 500 mm (22.2 x 9.4 x 19.7 inch)
Side Panel	4mm Tempered Glass x 1(Left)
Cooling System	Rear (exhaust) : 120 x 120 x 25 mm fan (1000rpm, 16 dBA) Front (intake) : 140 x 140 x 25 mm fan (1000rpm, 20dBA)
Drive Bays - Accessible - Hidden	2.5" x 2 or 3.5" x 2 (HDD Rack) 2.5" x 2
Expansion Slots	8
Motherboards	6.7" x 6.7" (Mini ITX), 9.6" x 9.6" (Micro ATX), 12" x 9.6" (ATX)
I/O Port	USB 3.0 x 2, USB 2.0 x 2, HD Audio x 1, Reset Button x 1
Fan Support	Front: 3 x 120 mm, 3 x 140 mm, 2 x 200 mm Top: 3 x 120 mm, 2 x 140 mm, 2 x 200 mm Rear: 1 x 120 mm
Radiator Support	Front: 1 x 360mm, 1 x 420mm Top: 1 x 280mm, 1 x 360mm Rear: 1 x 120mm Right: 1 x 360mm (Without HDD Rack)
Clearance	CPU cooler height limitation: 172 mm VGA length limitation: 282 mm (With HDD Rack) 400 mm (Without HDD Rack) PSU length limitation: 220 mm

Accessory

Figure	Part Name	Q'ty	Use For
	Stand-off #6-32 x 6.5 mm	2	For Motherboard
	Screw #6-32 x 6.5 mm	4	For PSU
	Screw #6-32 x 5 mm	15	For 3.5" HDD
	Screw M3 x 5 mm	36	For MB / 2.5"HDD / SSD / Riser cable
	Nut setter	1	For MB Stand-off
	Screw Ø5 x 12 mm	10	For Case Fan
	Screw #6-32 x 34 mm	16	For 200 mm Fan
	Screw Ø3 x 8 mm	1	For Strip stand
	PSU Cover strip stand	1	For VGA bracket base
	PSU strip stand	1	For VGA bracket base
	Cable Ties	10	Cable Management
	Buzzer	1	Motherboard Alarm

Warning and Notice

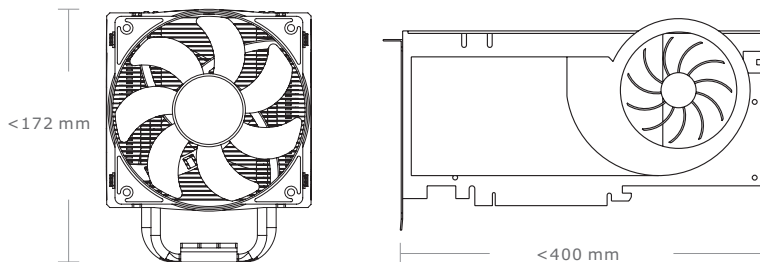

Warning!!

CPU Cooler Height Limitation:

Please ensure that your CPU cooler does NOT exceed 172 mm (6.77 inches) height.

VGA (Add-on card) Length Limitation:

Please ensure that your VGA (Add-on card) does NOT exceed 400 mm (15.74 inches) length.

Warnung!!

CPU-Kühler Höhenbeschränkung:

Bitte stellen Sie sicher, dass Ihr CPU-Kühler 172 mm (6,77 Zoll) Höhe nicht überschreitet.

VGA (Add-on-Karte) Längenbeschränkung:

Bitte stellen Sie sicher, dass Ihre VGA (Add-on-Karte) 400 mm (15,74 Zoll) Länge nicht überschreitet.

Avertissement !

Limite de hauteur du ventilateur de CPU :

Vérifiez que la hauteur du ventilateur de CPU ne dépasse pas 172 mm.

Limite de longueur de la carte (complémentaire) VGA :

Vérifiez que la longueur de votre carte (complémentaire) VGA ne dépasse pas 400 mm

Precaución

Limitación de altura del refrigerador de CPU:

Asegúrese de que la altura de su refrigerador de CPU no excede los 172 mm (6,77 pulgadas).

Limitación de longitud de la tarjeta de vídeo (adicional):

Asegúrese de que la longitud de su tarjeta de vídeo (adicional) no excede los 400 mm (15,74 pulgadas).

Attenzione!

Limitazione altezza dissipatore CPU:

Assicurarsi che l'altezza del dissipatore CPU NON superi 172 mm (6,77 pollici).

Limitazione lunghezza VGA (scheda aggiuntiva):

Assicurarsi che la lunghezza del VGA (scheda aggiuntiva) NON superi 400 mm (15,74 pollici).

Atenção!!

Limite de altura para o dissipador do CPU:

O limite de altura para o dissipador do CPU é 172 mm (6,77 polegadas).

Limite de comprimento para VGA (placa gráfica):

O limite de comprimento para VGA (placa gráfica) é 400 mm (15,74 polegadas).

警告！！

CPU 冷却器的高度限制：

請確保 CPU 冷却器的高度不超過 172 mm (6.77 英寸)。

VGA (附加介面卡) 的長度限制：

請確保 VGA (附加介面卡) 的長度不超過 400 mm (15.74 英寸)。

警告！！

CPU 散热器高度限制：

请确保 CPU 散热器的高度不超过 172 mm (6.77 英寸) 。

VGA (附加卡) 长度限制：

请确保 VGA (附加卡) 的长度不超过 400 mm (15.74 英寸) 。

警告

CPUクーラーの高さ制限:

CPUクーラーの高さが172mmを超えていないことを確認してください。

VGA (アドオンカード) の長さ制限:

VGA (アドオンカード) の長さが400mmを超えていないことを確認してください。

Внимание!

Ограничение по высоте охладителя ЦП

Убедитесь, что высота охладителя ЦП (центрального процессора) НЕ превышает 172 мм (6,77 дюйма).

Ограничение по длине видеокарты VGA (плата расширения)

Убедитесь, что длина видеокарты VGA (плата расширения) НЕ превышает 400 мм (15,74 дюйма).

Uyar!!

CPU Soğutucu Yükseklik Sınırlaması:

Lütfen CPU soğutucunuzun yüksekliğinin 172mm'yi (6,77 inç) GEÇMEDİĞİNDEN emin olun.

VGA (Ek kartı) Uzunluk Sınırlaması:

Lütfen VGA'nızın (Ek kartı) uzunluğunun 400mm'yi (15,74 inç) GEÇMEDİĞİNDEN emin olun.

คำเตือน!!

ขีดจำกัดความสูงสำหรับฮีตซิงก์ของ CPU:

ขีดจำกัดความสูงสำหรับฮีตซิงก์ของ CPU คือ 172 มม. (7.77 นิ้ว)

ขีดจำกัดความยาวสำหรับ VGA (การ์ดแสดงผล):

ขีดจำกัดความยาวสำหรับ VGA (การ์ดแสดงผล) คือ 400 มม. (15.74 นิ้ว)

Side Panels Disassembly

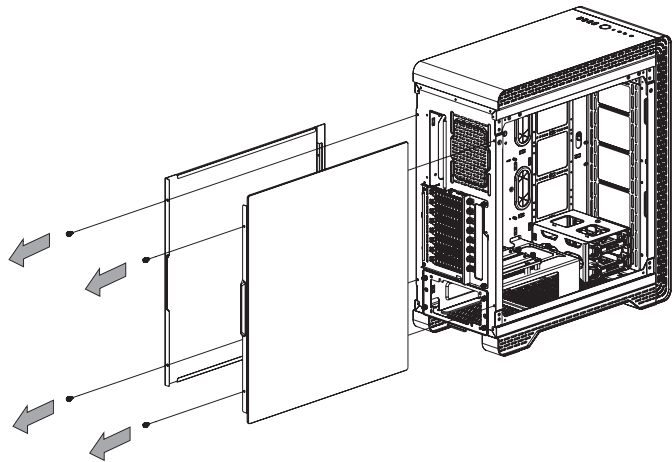

English /
Remove the screws on the back of the chassis,
and open the side panel.

Deutsch /
Entfernen Sie die Schrauben auf der Rückseite
des Gehäuses und öffnen Sie das Seitenteil.

Français /
Enlevez les vis à l'arrière du châssis et ouvrez le
panneau latéral.

Español /
Extraiga los tornillos de la parte posterior de la
caja y abra el panel lateral.

Italiano /
Rimuovere le viti sulla parte posteriore dello
chassis e aprire il pannello laterale.

Português /
Remova os parafusos na parte de trás da caixa e
abra o painel lateral.

繁體中文 /
移除機殼後方螺絲，將側窗打開。

简体中文 /
卸除机壳后方螺丝，将侧窗打开。

日本語 /
シャーシ背面のねじを取り外し、サイドパネ
ルを開きます。

Русский /
Открутите винты на задней стенке корпуса
и откройте боковую панель.

Türkçe /
Kasanın arkasındaki vidaları çıkarın ve yan
paneli açın.

ภาษาไทย /
ถอดสกรูที่ด้านหลังของแชสซีส์
แล้วเปิดแผงด้านขวา

Power Supply Unit (PSU) Installation

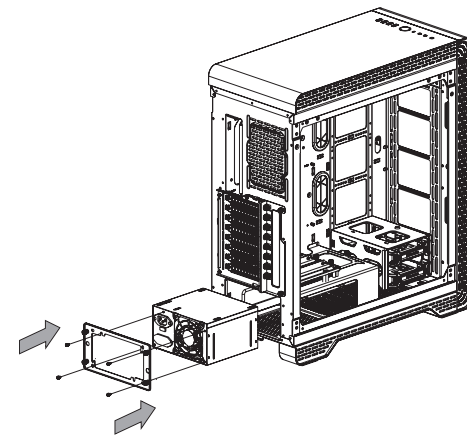

English /
Place the power supply in proper location and
secure it with screws.

Deutsch /
Installieren Sie das Netzteil an seiner Position und
sichern Sie es mit Schrauben.

Français /
Mettez l'alimentation dans le bon endroit et
sécurisez-la avec des vis.

Español /
Coloque el suministro de alimentación en el lugar
adecuado y asegúrelo con tornillos.

Italiano /
Posizionare l'alimentatore in modo appropriato e
fissarlo utilizzando le viti.

Português /
Coloque a fonte de alimentação na devida
localização e aparafuse.

繁體中文 /
將電源供應器放在正確的位置，並用螺絲固定
鎖上。

简体中文 /
恰当定位电源供应器位置并以螺丝安全固定。

日本語 /
電源装置を適切な場所に取り付け、ねじで固
定します。

Русский /
Установите блок питания в надлежащее
место и закрепите его винтами.

Türkçe /
Güç kaynağını uygun konuma yerleştirin ve
vidalarla sabitleyin.

ภาษาไทย /
วางแหล่งจ่ายไฟในตำแหน่งที่เหมาะสมแล้วขันสกรู
ยึดให้แน่น

Motherboard Installation

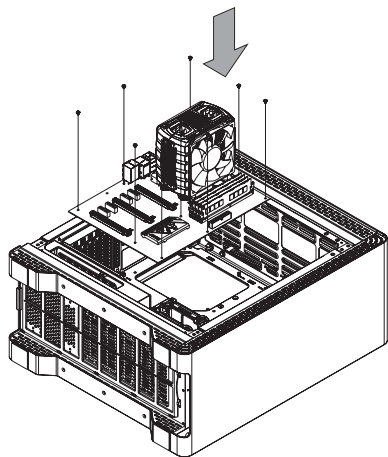

English /

- 1.Lay down the chassis.
- 2.Install the motherboard in proper location and secure it with screws.

Deutsch /

- 1.Legen Sie das Gehäuse auf die Seite.
- 2.Installieren Sie die Hauptplatine in ihrer vorgesehenen Position und sichern Sie sie mit Schrauben.

Français /

- 1.Posez à plat le châssis.
- 2.Installez la carte mère dans l'endroit approprié et sécurisez-la avec des vis.

Español /

1. Tumbé el chasis.
2. Instale la placa madre en la ubicación adecuada y asegúrela con tornillos.

Italiano /

- 1.Poggiare lo chassis.
- 2.Installare la scheda madre nella posizione appropriata e fissarla con le viti.

Português /

1. Deixe a caixa.
2. Instale a motherboard no local adequado e aparafuse.

繁體中文 /

1. 將機殼平放。
2. 將主機板放置在合適的位置並用零件包中之螺絲固定。

简体中文 /

1. 放平机箱。
2. 在合适的位置安装主板并以螺丝安全固定。

日本語 /

1. シャーシを下に置きます。
2. マザーボードを適切な場所に取り付け、ねじで固定します。

Русский /

1. Раскройте системный блок.
2. Установите материнскую плату в надлежащее место и закрепите ее винтами.

Türkçe /

- 1.Kasayı yan yatırın.
- 2.Ana kartı uygun konuma takın ve vidalarla sabitleyin.

ภาษาไทย /

1. วางแชสซีส์นอนลง
2. ติดตั้งเมนบอร์ดในตำแหน่งที่เหมาะสมแล้วขันสกรูยึดให้แน่น

3.5" & 2.5" HDD Installation

In front of M/B Tray

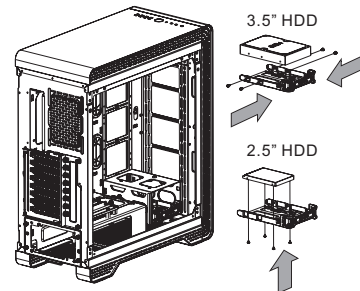

Top of the Power Cover

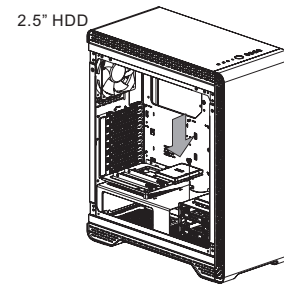

Behind M/B Tray B

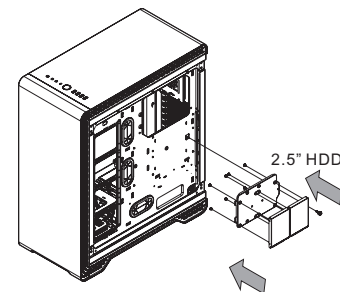
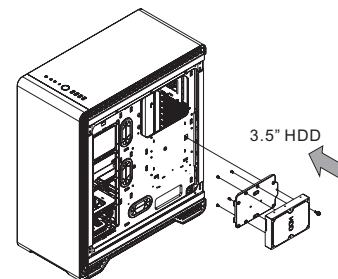

English /

Insert the HDD and tighten it with the screws.

Deutsch /

Führen Sie die Zoll HDD ein und befestigen Sie sie mit den Schrauben.

Français /

Insérez le disque dur de et sécurisez-le avec les vis.

Español /

Inserte el disco duro de y apriételo con los tornillos.

Italiano /

Inserire il dispositivo HDD da e fissarlo con le viti.

Português /

Insira o disco rígido de e aparafuse.

繁體中文 /

插入硬碟並用螺絲鎖上。

简体中文 /

插入硬盘并用螺丝锁上。

日本語 /

HDDを挿入し、ねじで締め付けます。

Русский /

Установите дюймовый жесткий диск и зафиксируйте его винтами.

Türkçe /

HDD'yi yerleştirin ve vidalarla sabitleyin.

ภาษาไทย /

ใส่ HDD ขนาด เข้าไปแล้วขันสกรูยึดให้แน่น

PCI Card Installation

Type A Traditional GPU installation

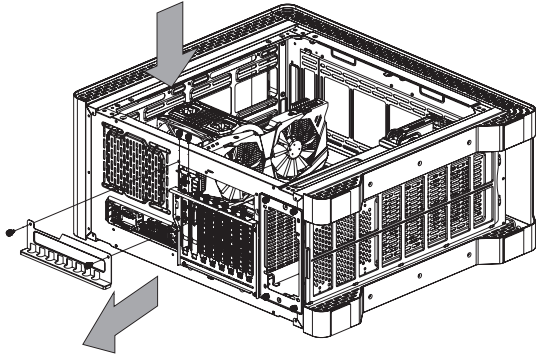

English /

1. Loosen the screws with a screwdriver.
2. Install the PCI card in proper location and secure it with screws.

Deutsch /

1. Lösen Sie die Schrauben mit einem Schraubendreher.
2. Installieren Sie die PCI-Card in der vorgesehenen Position und sichern Sie sie mit Schrauben.

Français /

1. Desserrez les vis à l'aide d'un tournevis.
2. Installez la carte PCI dans l'endroit approprié et fixez-la avec des vis.

Español /

1. Afloje los tornillos con un destornillador.
2. Instale la tarjeta PCI en la ubicación adecuada y asegúrela con tornillos.

Italiano /

1. Allentare le viti con un cacciavite.
2. Installare la scheda PCI nella posizione appropriata e fissarla con le viti.

Português /

1. Desaperte os parafusos com a chave de fendas.
2. Instale a placa PCI no local adequado e aparafuse.

繁體中文 /

1. 用螺絲起子將螺絲取下。
2. 將擴充卡放置在合適的位置並用螺絲固定。

简体中文 /

1. 用螺丝起子将螺丝取下。
2. 将扩充卡放置在合适的位置并用螺丝固定。

日本語 /

1. ドライバーでねじを緩めます。
2. PCI カードを適切な場所に取り付け、ねじで固定します。

Русский /

1. Ослабьте винты отверткой.
2. Установите плату PCI в надлежащий разъем и закрепите ее винтами.

Türkçe /

1. Vidaları, bir tornavida ile gevşetin.
2. PCI kartını uygun konuma takın ve vidalarla sabitleyin.

ภาษาไทย /

1. ใช้ไขควงขันสกรูออก
2. ติดตั้งการ์ด PCI ในตำแหน่งที่เหมาะสมแล้วขันสกรูยึดให้แน่น

Type B (Optional) Vertical GPU installation

※Riser Cable is not included

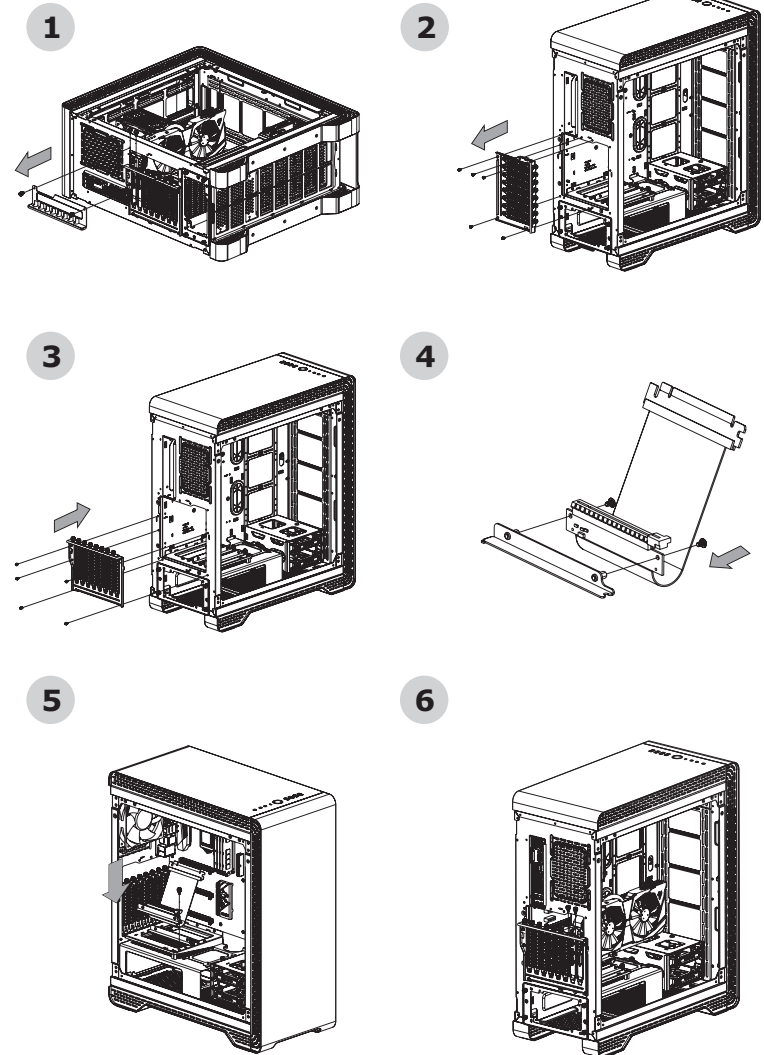

Air Cooling Installation

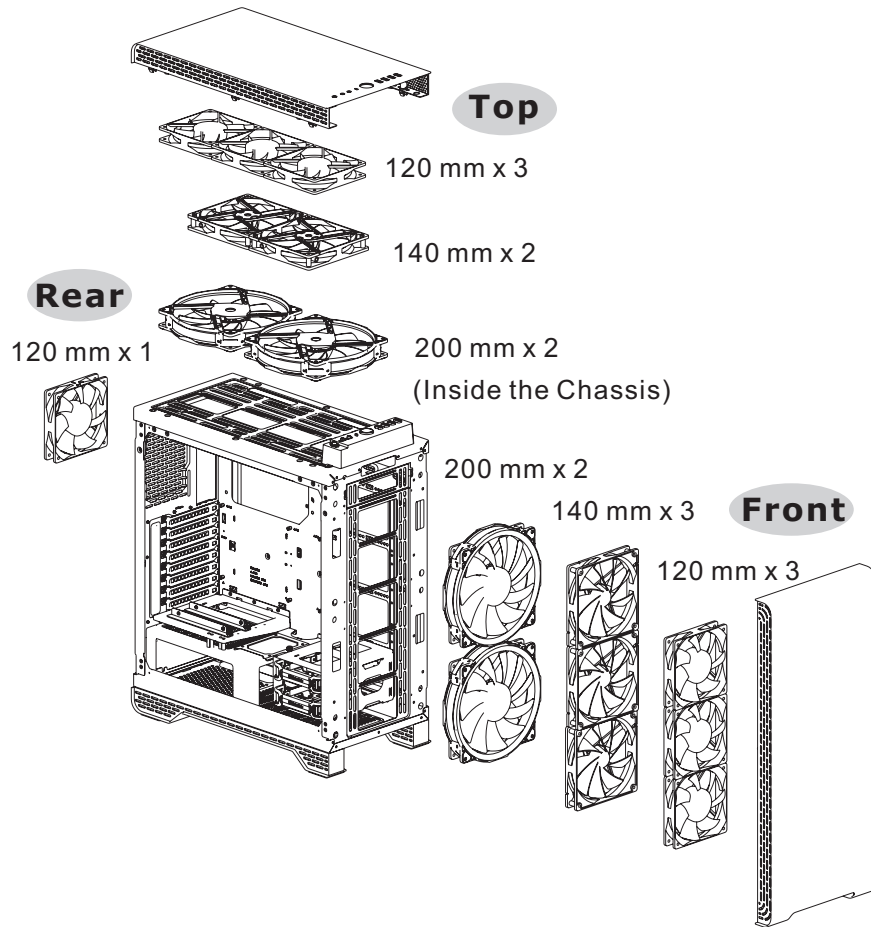

Liquid Cooling Installation

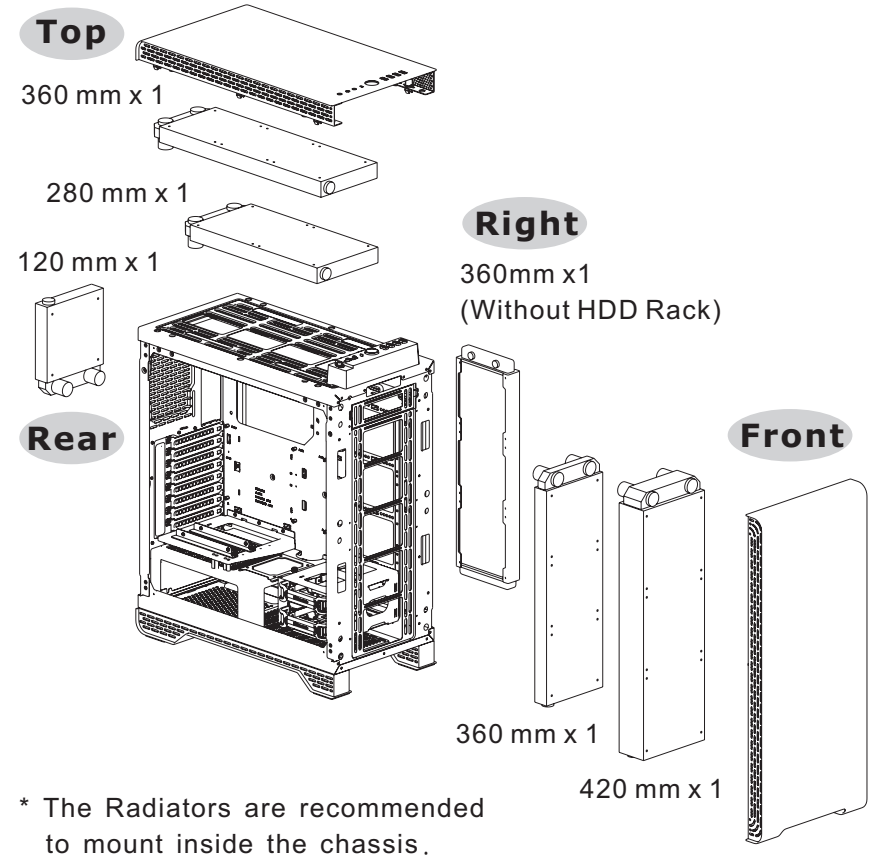

Max Radiator Installation Notice

Top Radiator Installation Notice

※Please consult radiator & memory height for proper installation

安裝前請參考水冷排與記憶體高度

Radiator: 360 mm x 64 mm (T/F)

Radiator: 280 mm x 55 mm (T)
420 mm x 55 mm (F)

Offset

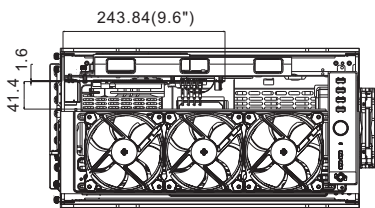

Offset

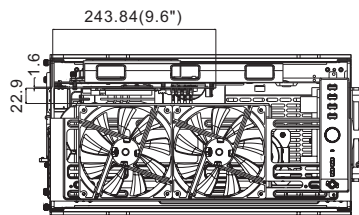

Top

120 mm Fan x 3

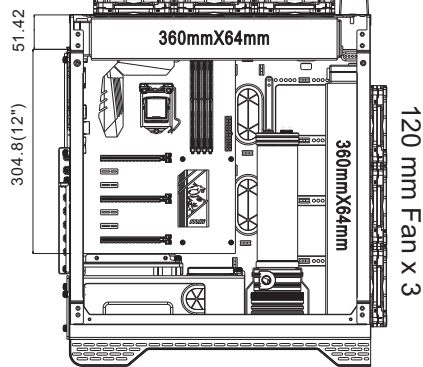

Front

Top

140 mm Fan x 2

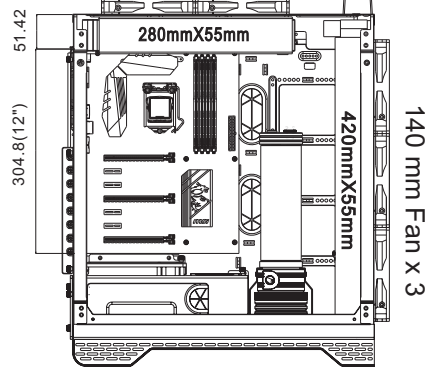

Front

Pump Installation

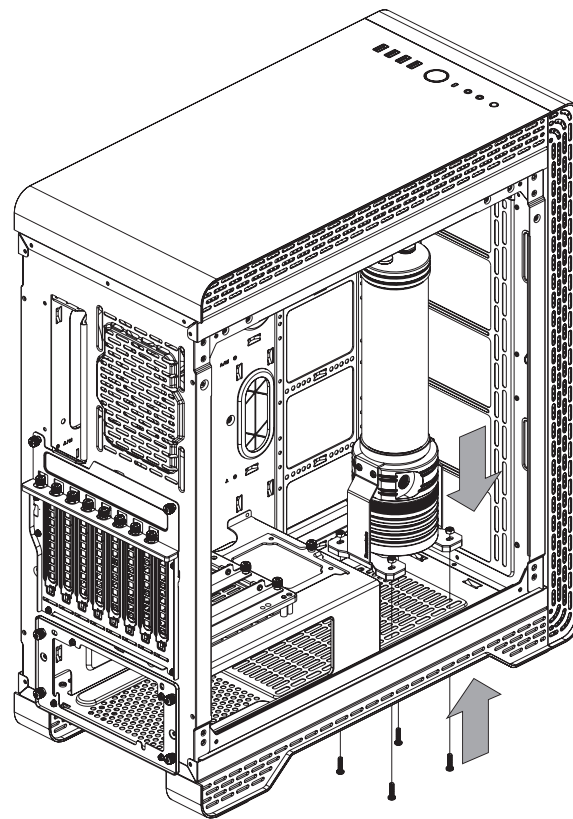

Leads Installation

English

Leads Installation Guide

A. Case LED Connection / On the front of the case, you can find some LEDs and switch leads. Please consult your user manual of your motherboard manufacturer, then connect these leads to the panel header on the motherboard.

B. USB 3.0 connection /

1. Make sure your motherboard supports USB 3.0 connection.
2. Connect the USB 3.0 cable to the available USB 3.0 port on your computer.

C. Audio Connection / Please refer to the following illustration of Audio connector and your motherboard user manual. Please select the motherboard which used AC'97 or HD Audio(Azalia), (be aware of that your audio supports AC'97 or HD Audio (Azalia) or it will damage your device(s).

Deutsch

Anschlüsse herstellen

A. Gehäuse-LED-Verbindungen / Auf der Gehäusevorderseite finden Sie einige LEDs und Verbindungen. Bitte nehmen Sie die Gebrauchsanweisung Ihres Motherboard Herstellers zur Hilfe und schließen Sie diese Verbindungen an die Panel Header Belegung des Motherboards an.

B. USB 3.0 Anschluss /

1. Stellen Sie sicher, dass Ihre Hauptplatte den USB 3.0 Anschluss unterstützt.
2. Verbinden Sie das USB 3.0 Kabel mit dem USB 3.0 Port auf Ihrem Computer.

C. Audio Anschlüsse / Bitte beachten Sie die folgende Abbildung der Audio Anschlüsse und die Anweisung in der Gebrauchsanweisung Ihres Motherboards. Bitte wählen Sie das Motherboard, das AC'97 oder HD Audio(Azalia) verwendet, (achten Sie darauf, dass Ihr Audio AC'97 bzw. HD Audio (Azalia unterstützt)). Andernfalls entstehen schwere Schäden an Ihrem(n) Gerät(en)!!!

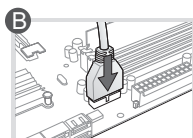

USB 3.0 Connection

C AUDIO HD AUDIO Function

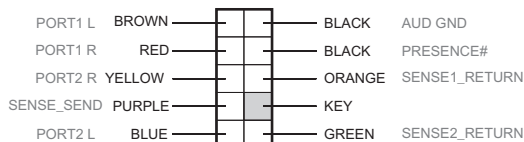

Français

Guide d'installation des fils

A. Connexion des voyants du boîtier / Sur la face avant du boîtier, vous trouverez plusieurs voyants et les fils des boutons. S'il vous plaît consultez le guide d'utilisateur du fabricant de votre carte mère, puis connectez ces fils aux connecteurs sur la carte mère.

B. Connexion USB 3.0 /

1. Vérifiez que votre carte mère prend en charge la connexion USB 3.0.
2. Connectez le câble USB 3.0 au port USB 3.0 disponible sur votre ordinateur.

C. Connexion Audio / S'il vous plaît référez vous à l'illustration suivante du connecteur audio et au guide de l'utilisateur de votre carte mère. S'il vous plaît sélectionnez une carte mère supportant AC'97 ou HD Audi (Azalia), (faites attention que votre audio supporte l'AC'97 ou HD Audio (Azalia) sinon cela pourrait endommager votre matériel.

Español

Guía de Instalación de Cables

A. Conexión del LED de la caja / En la parte frontal de la caja, encontrará algunos LED y cables de interruptores. Consulte el manual del usuario del fabricante de la placa madre, a continuación conecte estos cables al conector de la placa madre.

B. Conexión USB 3.0 /

1. Asegúrese de que la placa base admite conexión USB 3.0.
2. Conecte el cable USB 3.0 al puerto USB 3.0 disponible en el equipo.

C. Conexión de Audio / Consulte la siguiente ilustración del conector de Audio y el manual del usuario de la placa madre. Seleccione la placa madre que utiliza AC'97 o HD Audio (Azalia), (asegúrese de que su audio admite AC'97 o HD Audio (Azalia) si no, sus dispositivos resultarán dañados

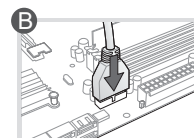
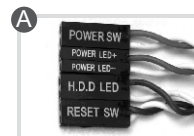

USB 3.0 Connection

C AUDIO HD AUDIO Function

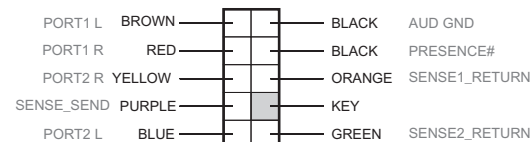

Italiano

Guida di installazione dei contatti

A. Connessione del LED del case / Nella parte anteriore del case, sono presenti alcuni contatti per interruttori e LED. Consultare il manuale utente del produttore della scheda madre, quindi connettere i contatti alla parte superiore del pannello sulla scheda madre.

B. Connessione USB 3.0 /

1. Accertarsi che la scheda madre supporti la connessione USB 3.0.
2. Collegare il cavo USB 3.0 alla porta USB 3.0 disponibile sul computer.

C. Connessione Audio / Fare riferimento all'illustrazione riportata di seguito del connettore Audio e al manuale utente per la scheda madre. Selezionare la scheda madre relativa a AC'97 o HD Audio (Azalia) e considerare che il supporto audio è compatibile con AC'97 o HD Audio (Azalia); in caso contrario, le periferiche potrebbero venire danneggiate.

Português

Guia de Instalação Eléctrica

A. Ligação do LED da Caixa / Na parte dianteira da caixa pode encontrar alguns LEDs e fios eléctricos. Consulte o manual de utilizador do fabricante da sua motherboard e ligue os fios à parte superior do painel na motherboard.

B. Ligação USB 3.0 /

1. Certifique-se que a sua motherboard suporta ligação USB 3.0.
2. Ligue o cabo USB 3.0 à porta USB 3.0 disponível no seu computador.

C. Ligação Áudio / Consulte a imagem seguinte do conector Áudio e o manual de utilizador da sua motherboard. Selecione a motherboard que utiliza AC'97 ou HD Áudio (Azalia), (verifique se a sua placa de áudio suporta AC'97 ou HD Áudio (Azalia)) ou irá danificar o(s) seu(s) dispositivo(s).

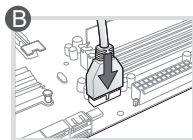
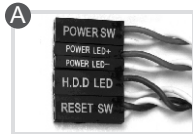

USB 3.0 Connection

C AUDIO HD AUDIO Function

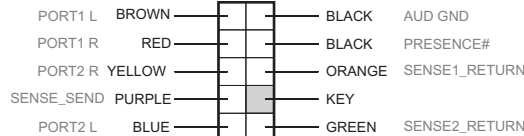

繁體中文

線材安裝說明

A. 機殼LED連接方式 / 在機殼前方的面板後面，可以找到一些LED與開關線材 (POWER Switch....)，請參考主機板使用說明書，並將機殼上的線材正確地連接到主機板上，這些線材通常都會印有標籤在上面，如果沒有的話，請找出機殼前方面板上線材原本的位置以知道正確的來源。

B. USB 3.0 連接 /

1. 請確認主機板是否支援USB 3.0傳輸介面。
2. 連接USB 3.0傳輸線至主機板上的USB3.0埠。

C. 音效連接 / 請根據下面的音源接頭圖示與主機板使用手冊來連接音效裝置，請確認主機板上的音效裝置是支援AC'97音效或是HD音效 (Azalia)，裝置錯誤可能會導致主機板音效裝置的毀損，某些主機板的音效裝置不會與下方的圖示完全相同，請參酌主機板使用手冊以得到正確的安裝資訊。

简体中文

线材安装说明

A. 机壳LED连接方式 / 在机壳前方的面板后面，可以找到一些LED与开关线材 (POWER Switch....)，请参考主板使用说明书，并将机壳上的线材正确地连接到主板上，这些线材通常都会印有标签在上面，如果没有的话，请找出机壳前方面板上线材原本的位置以知道正确的来源。

B. USB 3.0 连接 /

1. 请确认主板是否支持USB 3.0传输接口。
2. 连接USB 3.0传输线至主板上的USB3.0埠。

C. HD音效 (Azalia)，装置错误可能会导致主板音效装置的毁损，某些主板的音效装置不会与下方的图标完全相同，请参酌主板使用手册以得到正确的安装信息。

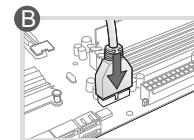
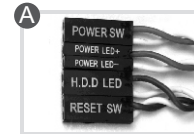

USB 3.0 Connection

C AUDIO HD AUDIO Function

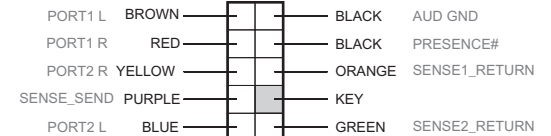

日本語

リード線の取り付けガイド

A. ケース LED の接続 / ケース前面には、LEDとスイッチリード線があります。 マザーボードメーカーのユーザーマニュアルを参照し、これらのリード線をマザーボードのパネルヘッダに接続してください。

B. USB 3.0 の接続 /

1. お使いのマザーボードがUSB 3.0接続をサポートしていることを確認してください。
2. USB 3.0ケーブルをコンピュータの空いているUSB 3.0ポートに接続します。

C. オーディオ接続 / オーディオコネクタの次の図とマザーボードのユーザーマニュアルを参照してください。AC'97またはHDオーディオ(Azalia)を使用するマザーボードを選択してください(オーディオがAC'97またはHDオーディオ(Azalia)をサポートしていることを確認してください)。サポートしていないと、デバイスが損傷します)。

Русский

Указания по прокладке кабелей

A. Подключение индикаторов корпуса / В передней части корпуса расположены индикаторы и провода выключателя. Перед подсоединением этих проводов к монтажной колодке панели на материнской плате изучите руководство пользователя производителя материнской платы.

B. Подключение USB 3.0 /

1. Убедитесь, что материнская плата поддерживает подключение по стандарту USB 3.0.
2. Подсоедините кабель USB 3.0 к свободному порту USB 3.0 компьютера.

C. Подключение аудиоразъема / См. следующую иллюстрацию аудиоразъема и руководство пользователя материнской платы. Выберите материнскую плату, в которой используется кодек AC'97 или HD Audio (Azalia) (убедитесь, что звуковая плата поддерживает кодек AC'97 или HD Audio (Azalia)). В противном случае можно повредить устройства.

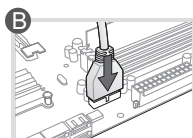

USB 3.0 Connection

C AUDIO HD AUDIO Function

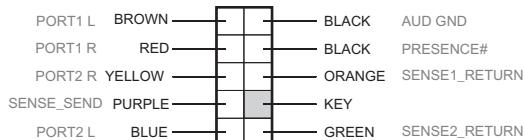

Türkçe

Ara Kablo Kurulum Kılavuzu

A. Kasa ışık bağlantısı / Kasanın ön kısmında bazı ışıklar ve anahtar ara kabloları görebilirsiniz. Lütfen anakart üreticinizin sağladığı kullanım kılavuzuna bakın ve daha sonra, bu ara kabloları, anakart üzerindeki panel bağlantı noktalarına bağlayın.

B. USB 3.0 Bağlantısı /

1. Ana kartınızın USB 3.0 bağlantısını desteklediğinden emin olun.
2. USB 3.0 kablousunu, bilgisayarınızdaki kullanılabilir USB 3.0 bağlantı noktasına bağlayın.

C. Ses Bağlantısı / Lütfen aşağıdaki Ses konektörü resmine ve anakartınızın kullanım kılavuzuna bakın. Lütfen AC'97 veya HD Audio(Azalia) spesifikasyonunu kullanan bir anakart seçin (ses sisteminizin AC'97 veya HD Audio (Azalia) spesifikasyonunu desteklediğini unutmayın); aksi takdirde, aygıt(lar)ınız zarar görür.

ภาษาไทย

คู่มือการติดตั้งสายไฟ

A. การเชื่อมต่อไฟ LED ของเคส / ที่ด้านหน้าของเคส คุณจะเห็นไฟ LED และสายไฟของสวิตช์ กรณีศึกษารายละเอียดจากคู่มือผู้ใช้ของผู้ผลิตแผงวงจรหลักของคุณ จากนั้นให้เชื่อมต่อสายไฟเหล่านี้เข้ากับส่วนหัวของแผงบนแผงวงจรหลัก

B. การเชื่อมต่อ USB 3.0 /

1. ตรวจสอบให้แน่ใจว่าแผงวงจรหลักของคุณรองรับการเชื่อมต่อ USB 3.0
2. เชื่อมต่อสาย USB 3.0 เข้ากับพอร์ต USB 3.0 ที่สามารถใช้งานได้บนคอมพิวเตอร์ของคุณ

C. การเชื่อมต่ออุปกรณ์รับส่งสัญญาณเสียง / กรุณาดูรายละเอียดจากภาพประกอบของตัวเชื่อมต่อสัญญาณเสียงต่อไปนี้ และคู่มือผู้ใช้ของผู้ผลิตแผงวงจรหลักของคุณ กรุณาเลือกแผงวงจรหลักที่ใช้ AC'97 หรือ HD Audio(Azalia) (กรุณาตรวจสอบให้แน่ใจว่าอุปกรณ์รับส่งสัญญาณเสียงของคุณรองรับ AC'97 หรือ HD Audio (Azalia)) มิฉะนั้นอุปกรณ์ของคุณอาจเสียหายได้

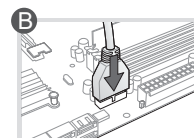
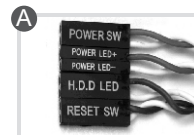

USB 3.0 Connection

C AUDIO HD AUDIO Function

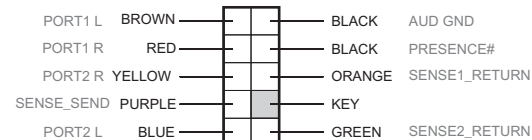

Thermaltake Power Supply Series (Optional)



What is Smart Power Management (SPM)?

Smart Power Management (SPM) is a cloud-based software that seamlessly integrates three intelligent platforms – DPS G PC APP 3.0, DPS G Smart Power Management Cloud 1.0 and DPS G Mobile APP 1.0 – and compiles key statistics about your PC into detailed charts and breakdowns for your instant PC status view and management. With easy access to SPM through your PC or mobile devices, whether you are outside or indoors, enjoy taking full control of your build anytime, anywhere!



Thermaltake has several power supply product lines; please refer to our official website and Facebook Fan Page for more detail information!

Brand official website:

<http://www.thermaltake.com/>

Global Facebook :

<https://www.facebook.com/ThermaltakeInc>

Taiwan Facebook

<https://www.facebook.com/ThermaltakeTW>



Tt RGB Plus Ecosystem



Tt RGB Plus Software

Thermaltake's patented software to synchronize TT RGB PLUS products with addressable LEDs.



Tt AI Voice Control

Give you full control over the TT RGB PLUS products with your voice.

SyncALL, Say "Hello TT"



Download on the App Store



GET IT ON Google play



Learn more about TT RGB Plus

Ovaj dokument je originalno proizveden i objavljen od strane proizvođača, brenda Thermaltake, i preuzet je sa njihove zvanične stranice. S obzirom na ovu činjenicu, Tehnoteka ističe da ne preuzima odgovornost za tačnost, celovitost ili pouzdanost informacija, podataka, mišljenja, saveta ili izjava sadržanih u ovom dokumentu.

Napominjemo da Tehnoteka nema ovlašćenje da izvrši bilo kakve izmene ili dopune na ovom dokumentu, stoga nismo odgovorni za eventualne greške, propuste ili netačnosti koje se mogu naći unutar njega. Tehnoteka ne odgovara za štetu nanесenu korisnicima pri upotrebi netačnih podataka. Ukoliko imate dodatna pitanja o proizvodu, ljubazno vas molimo da kontaktirate direktno proizvođača kako biste dobili sve detaljne informacije.

Za najnovije informacije o ceni, dostupnim akcijama i tehničkim karakteristikama proizvoda koji se pominje u ovom dokumentu, molimo posetite našu stranicu klikom na sledeći link:

<https://tehnoteka.rs/p/thermaltake-kuciste-s500-belo-akcija-cena/>