

Uputstvo za upotrebu (EN)

NZXT kućište H510 Flow CA-H52FB-01 crno

NZXT



Tehnoteka je online destinacija za upoređivanje cena i karakteristika bele tehnike, potrošačke elektronike i IT uređaja kod trgovinskih lanaca i internet prodavnica u Srbiji. Naša stranica vam omogućava da istražite najnovije informacije, detaljne karakteristike i konkurentne cene proizvoda.

Posetite nas i uživajte u ekskluzivnom iskustvu pametne kupovine klikom na link:

<https://tehnoteka.rs/p/nzxt-kuciste-h510-flow-ca-h52fb-01-crno-akcija-cena/>

NZXT

H510 FLOW

PREMIUM COMPACT MID-TOWER ATX CASE

EXPLODED VIEW

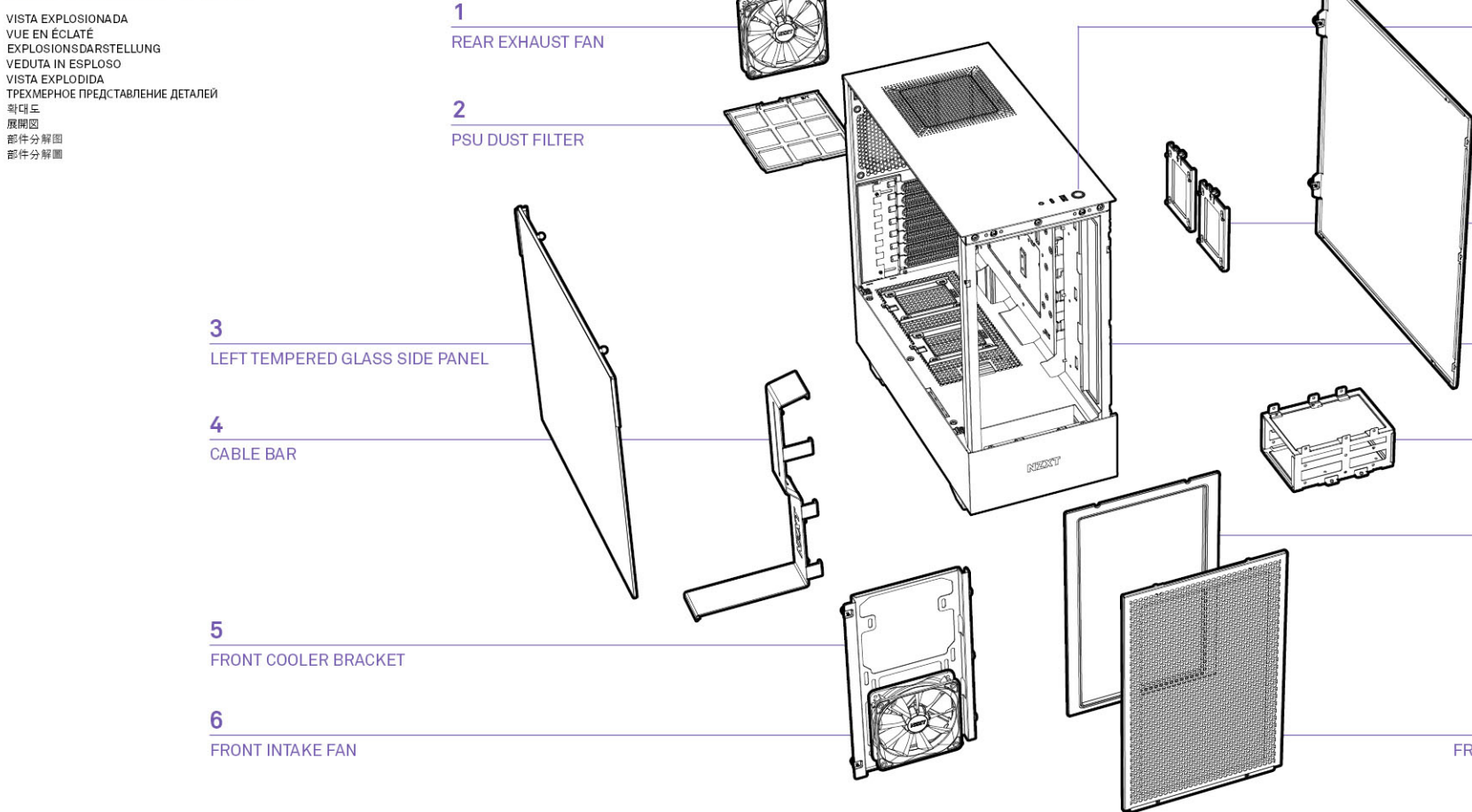

1 REAR EXHAUST FAN

2 PSU DUST FILTER

3 LEFT TEMPERED GLASS SIDE PANEL

4 CABLE BAR

5 FRONT COOLER BRACKET

6 FRONT INTAKE FAN

7 FRONT I/O

8 RIGHT METAL PANEL

9 SSD TRAY

10 CHASSIS

11 HDD CAGE

12 FRONT FILTER

13 FRONT MESH PANEL

- | | | | | | | | | | |
|--|---|--|---|---|--|--|--|--|--|
| 1. Ventilador de escape trasero
2. Filtro de polvo de la PSU
3. Panel de vidrio templado lateral izquierdo
4. Barra de limpieza
5. Soporte del refrigerador frontal
6. Ventilador de admisión frontal
7. E/S frontal
8. Panel metálico derecho
9. Bandeja unidad de estado sólido
10. Chasis
11. Compartimento de disco rígido
12. Filtro frontal
13. Panel de malla frontal | 1. Ventilator d'échappement arrière
2. Filtre à poussière du bloc d'alimentation
3. Panneau latéral gauche en verre trempé
4. Barre pour la gestion des câbles
5. Support du dissipateur avant
6. Ventilateur d'admission avant
7. E/S avant
8. Panneau métallique droit
9. Plateau SSD
10. Châssis
11. Plateau pour disque dur
12. Filtre avant
13. Panneau avant en filot | 1. Lüfter für Luftauslass an Rückseite
2. Netzteil-Staubfilter
3. Hartglasfenster links
4. Reinigungseleite
5. Stütze für Kühlkörper an Vorderseite
6. Ansaugfilter vorne
7. E/A an der Vorderseite
8. Seitliche Abdeckung rechts aus Metall
9. SSD-Fach
10. Gehäuse
11. Festplatteneinsatz
12. Frontfilter
13. Mesh-Einsatz vorne | 1. Ventilador de escape posterior
2. Filtro de polvo de alimentatore
3. Panelo lateral izquierdo en vidrio templado
4. Barra de gestión de los cables
5. Soporte de ventilador anterior
6. Ventilador de entrada frontal
7. I/O anterior
8. Panelo derecho in metalo
9. Cassetto SSD
10. Chassi
11. Bandeja de unidad de disco duro
12. Filtro Frontal
13. Panelo frontal in rete | 1. Ventiloinha de exaustão traseira
2. Filtro de pó do PSU
3. Painel lateral esquerdo em vidro temperado
4. Barra de limpeza
5. Suporte da ventoinha anterior
6. Ventilador de entrada frontal
7. E/S frontal
8. Painel de metal direito
9. Tabuleiro de SSD
10. Chassi
11. Bandeja de unidade de disco duro
12. Filtro Frontal
13. Painel de malha frontal | 1. Задний выхлопной вентилятор
2. Фильтр пыли блока питания
3. Левая боковая панель из закаленного стекла
4. Панель Clean view
5. Кронштейн переднего системы охлаждения
6. Передний пылевой вентилятор
7. Разъем спереди
8. Правая металлическая панель
9. Лоток для твердотельных накопителей
10. Корпус
11. Лоток для жесткого диска
12. Передний фильтр
13. Передняя сетчатая панель | 1. 后部排气扇
2. PSU 防尘过滤器
3. 左侧钢化玻璃侧板
4. 透明可视板
5. 前置散热器支架
6. 前置防尘风扇
7. 前置 I/O
8. 右侧金属面板
9. SSD 托架
10. 机箱
11. 硬盘架
12. 前置滤网
13. 前置网板 | 1. 后部排气扇
2. PSU 防尘过滤器
3. 左侧钢化玻璃侧板
4. 透明可视板
5. 前置散热器支架
6. 前置防尘风扇
7. 前置 I/O
8. 右侧金属面板
9. SSD 托架
10. 机箱
11. 硬盘架
12. 前置滤网
13. 前置网板 | 1. 后部排气扇
2. PSU 防尘过滤器
3. 左侧钢化玻璃侧板
4. 透明可视板
5. 前置散热器支架
6. 前置防尘风扇
7. 前置 I/O
8. 右侧金属面板
9. SSD 托架
10. 机箱
11. 硬盘架
12. 前置滤网
13. 前置网板 | 1. 后部排气扇
2. PSU 防尘过滤器
3. 左侧钢化玻璃侧板
4. 透明可视板
5. 前置散热器支架
6. 前置防尘风扇
7. 前置 I/O
8. 右侧金属面板
9. SSD 托架
10. 机箱
11. 硬盘架
12. 前置滤网
13. 前置网板 |
|--|---|--|---|---|--|--|--|--|--|

CLEARANCES AND SPECIFICATIONS

Motherboard Support	ATX, Micro-ATX, Mini-ITX	Placas base admitidas	ATX, Micro-ATX, Mini-ITX	Поддержка материнской платы	ATX, Micro-ATX, Mini-ITX
2.5" SSD Support	2+1	Unidad de estado sólido de 2.5"	2+1	для твердотельных накопителей 2.5"	2+1
3.5" HDD Support	2+1	Unidad de disco duro de 3.5"	2+1	для жестких дисков 3.5"	2+1
Expansion Slots	7	Ranuras de expansión	7	Разъемы расширения	7
GPU Clearance	368.6mm	Distancia de seguridad para GPU	368.6mm	Защитное расстояние для видеокарты	368.6mm
Cable Management	19-23mm	Administración de los cables	19-23mm	Организация кабельных систем	19-23mm
GPU Cooler Clearance	165mm	Dissipador de la GPU	165mm	Высота радиатора	165mm
Front Radiator	60mm	Radiador frontal	60mm	Передний радиатор	60mm

Case mère prises en charge	ATX, Micro-ATX, Mini-ITX	SSD 2.5"	2+1	Disques durs 3.5"	2+1	Bases d'extension	7	Longueur du GPU	368.6mm	Gestion des câbles	19-23mm	Radiateur du processeur	165mm	Radiateur avant	60mm
Motherboard-Unterstützung	ATX, Micro-ATX, Mini-ITX	2.5-Zoll-SSD	2+1	3,5-Zoll-Festplatte	2+1	Erweiterungsteilplätze	7	Kabelverlängerung	19-23mm	GPU-Kühler	165mm	Vorderer Kühlkörper	60mm	Scheda madre supportata	ATX, Micro-ATX, Mini-ITX
SSD de 2.5"	2+1	HDD de 3.5"	2+1	Alloggi d'espansione	7	Spazio necessario alla GPU	368.6mm	Gestione dei cavi	19-23mm	Dispositivo di calore GPU	165mm	Radiatore frontale	60mm	SSD de 2.5"	2+1
HDD de 3.5"	2+1	Alloggi d'espansione	7	Spazio necessario alla GPU	368.6mm	Gestione dei cavi	19-23mm	Dispositivo di calore GPU	165mm	Radiatore frontale	60mm	Placa-principais suportadas	ATX, Micro-ATX, Mini-ITX	SSD de 2.5"	2+1
Placa-principais suportadas	ATX, Micro-ATX, Mini-ITX	SSD de 2.5"	2+1	HDD de 3.5"	2+1	Ranuras de expansão	7	Forma da GPU	368.6mm	Gestão de cabos	19-23mm	Dissipador de CPU	165mm	Radiador frontal	60mm

ACCESSORY BOX

A Hexagon Screw 6-32 x 6mm	x4	E Standoff 6-32 x 6.5+4mm	x1
B Screw 6-32 x 5mm	x21	F Standoff Wrench	x1
C Screw M3 x 5mm	x12	G Cable Tie	x10
D Screw K85 x 10mm	x8	H Breakout Cable	x1
I 3.5mm Headset audio jack splitter	x1		

A. Tornillo hexagonal de 6-32 x 6 mm	Instalación de la fuente de alimentación	A. Vis hexagonale 6-32 x 6 mm	Installation de l'alimentation électrique
B. Tornillo 6-32 x 5 mm	Instalación de la placa base e instalación de la unidad de disco duro de 3,5"	B. Schraube 6-32 x 5 mm	Installation de la carte mère, installation du disque dur 3,5"
C. Tornillo M3 x 5 mm	Instalación de la unidad de disco duro de 2,5"	C. Vis M3 x 5 mm	Installation du disque dur 2,5"
D. Tornillo K85 x 10 mm	Instalación del ventilador	D. Vite K85 x 10 mm	Installation du ventilateur
E. Separador 6-32 x 6,5 +4 mm	Instalación de la placa base	E. Entretoise 6-32 x 6,5 + 4 mm	Installation de la carte mère
F. Clave para separadores	Instalación de la placa base	F. Clave pour séparateurs	Installation de la carte mère
G. Banda para cables	Administración de los cables	G. Bandeja para cables	Gestion du câblage
H. Cable multiconector	Para panel frontal de placas base non-Intel	H. Cable multi connectons	Pour le connecteur Front Panel de cartes mères non-Intel
I. Divisor del conector de audio de los auriculares de 3,5mm	Convierta un solo puerto de audio de 3,5 mm a 4 polos en dos puertos de audio de 3,5 mm y 3 polos	I. Reparteur audio jack 3,5 mm pour casque	Convertissez un seul port audio 3,5 mm à 4 pôles en deux ports audio 3,5 mm à 3 pôles

A. Винт шестигранный 6-32 x 6 мм	Установка источника питания	A. 육각나사 6-32 x 6mm	전원공급장치 설치
B. Винт 6-32 x 5 мм	Установка материнской платы, установка жесткого диска 3,5"	B. 나사 6-32 x 5mm	이더넷 포트 설치
C. Винт M3 x 5 мм	Установка жесткого диска 2,5"	C. 나사 M3 x 5mm	2.5인치 하드 드라이브 설치
D. Винт K85 x 10 мм	Установка вентилятора	D. 나사 K85 x 10mm	팬 설치
E. Стойка 6-32 x 6,5 +4 мм	Установка материнской платы	E. 스탠드 6-32 x 6.5+4mm	이더넷 포트 설치
F. Плачевый ключ	Установка материнской платы	F. 스탠드 6-32 x 6.5+4mm	이더넷 포트 설치
G. Кабельный хомут	Организация кабельных систем	G. 케이블 클립	케이블 정리
H. Кабель-разветвитель	Для подключения фронтальной панели к материнским платам с разъемом Intel стандарта	H. 브레이크아웃 케이블	이더넷 포트 연결
I. Разъем 3,5 мм для наушников	Преобразование одного 3,5-мм 4-полюсного аудиопорта в два 3,5-мм 3-полюсных аудиопорта	I. 3.5mm 헤드셋 오디오 잭 스플리터	단일 3.5mm 4 극 오디오 포트를 2 개의 3.5mm 3 극 오디오 포트로 변환

CABLE CONNECTIONS

A. 六角螺丝 6-32 x 6mm	安装电源	A. 六角螺丝 6-32 x 6mm	安装电源
B. 螺丝 6-32 x 5mm	主板安装, 3.5 HDD 安装	B. 螺丝 6-32 x 5mm	主板安装, 3.5 硬盘安装
C. 螺丝 M3 x 5mm	2.5 HDD 安装	C. 螺丝 M3 x 5mm	2.5 硬盘安装
D. 螺丝 K85 x 10mm	风扇安装	D. 螺丝 K85 x 10mm	风扇安装
E. 支架 6-32 x 6.5+4mm	主板安装	E. 支架 6-32 x 6.5+4mm	主板安装
F. 塑料撬棒	主板安装	F. 塑料撬棒	主板安装
G. 线缆束带	线缆管理	G. 线缆束带	线缆管理
H. 分线器	用于非英特尔主板主板板接口	H. 分线器	用于非英特尔主板板接口
I. 3.5mm 耳机插孔分配器	将一个 3.5mm 4 极音频接口转换为两个 3.5mm 3 极音频接口	I. 3.5mm 耳机插孔分配器	将一个 3.5mm 4 极音频接口转换为两个 3.5mm 3 极音频接口

BUTTONS AND I/O

1. Salida de audio HD	2. USB 3.1 Gen2 Type-C	3. USB 3.1 Gen1 Type-A	4. LED de unidad de disco duro	5. LED de alimentación	6. Interruptor de encendido
1. Звуковой выход HD	2. USB 3.1 Gen2 Type-C	3. USB 3.1 Gen1 Type-A	4. Индикатор жесткого диска	5. Индикатор питания	6. Выключатель питания
1. Sortie audio HD	2. USB 3.1 Gen2 Type-C	3. USB 3.1 Gen1 Type-A	4. Témoin disque dur	5. Témoin LED	6. Interrupteur marche/arrêt
1. HD-Audioausgang	2. USB 3.1 Gen2 Type-C	3. USB 3.1 Gen1 Type-A	4. LED HDD	5. LED-Beleuchtung	6. Netzschalter
1. Salida de audio HD	2. USB 3.1 Gen2 Type-C	3. USB 3.1 Gen1 Type-A	4. LED HDD	5. LED de alimentación	6. Interruptor de alimentación
1. 高清音频输出	2. USB 3.1 Gen2 Type-C	3. USB 3.1 Gen1 Type-A	4. 硬盘 LED	5. 电源 LED	6. 电源开关

PANEL REMOVAL

EXTRACCIÓN DE PANEL
RETRAIT DU PANNEAU
BLEND ENTERRÉEN
RIMOZIONE DEL PANNELLO
REMOÇÃO DOS PAINÉIS
CRITTE TÄHNER
可拆盖板
/ 후치(后插)외리
卸下蓋板

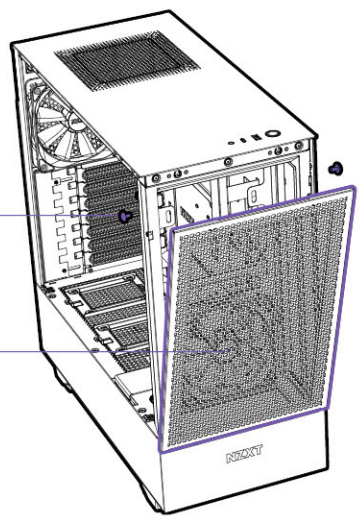

STEP 1

LOCATE AND REMOVE SCREWS

STEP 2

REMOVE PANEL

STEP 3

UNSCREW CAPTIVE THUMB SCREW

STEP 4

PULL TOP OF GLASS PANEL

STEP 5

LIFT AND REMOVE PANEL

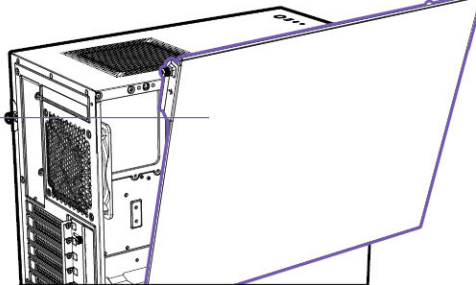
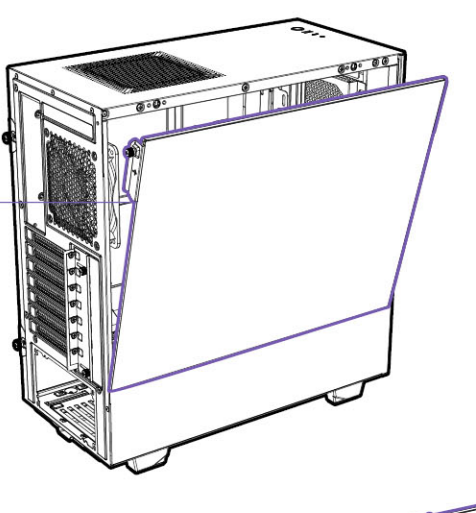

HDD DRIVE INSTALLATION

INSTALACIÓN DE LA UNIDAD DE DISCO DURO
INSTALLATION DE LECTEUR HDD
HDD-LAUFWERKINSTALLATION
INSTALLAZIONE DELL'UNITÀ HDD
INSTALAÇÃO DA PLACA DE EXPANSÃO
УСТАНОВКА ЖЕСТКОГО ДИСКА
HDD 安裝
HDD 安裝
HDD 安裝
HDD 安裝
HDD 安裝

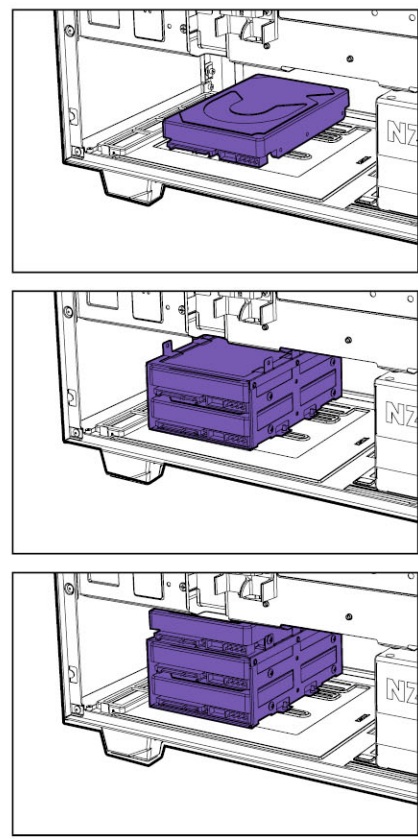
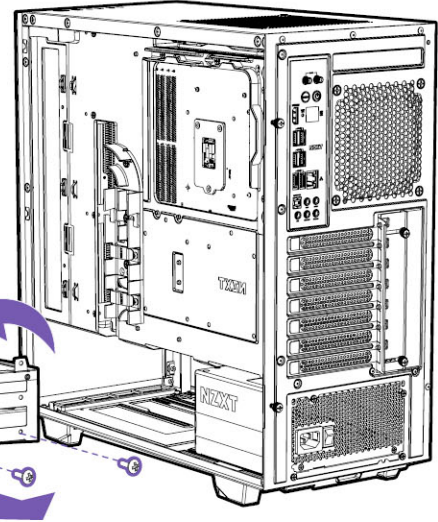
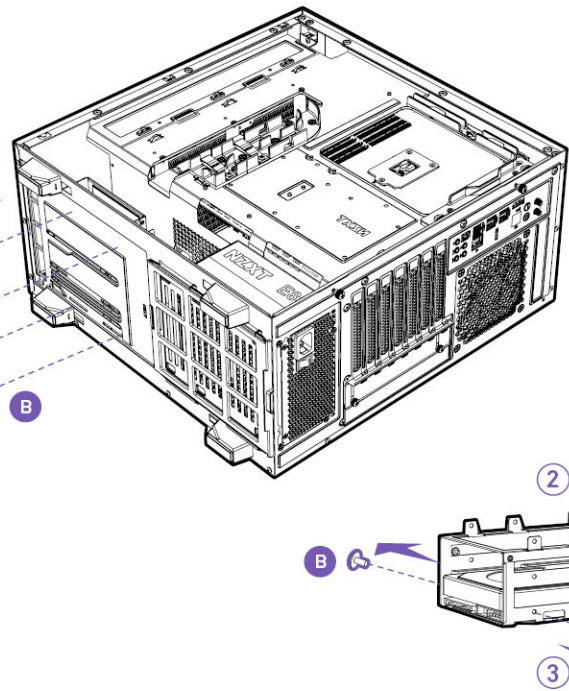

限用物质及元素列表 / 限用物質及元素清單

Table with columns: 产品名称: 机箱·H系列, 有害物质, 铅(Pb), 镉(Cd), 汞(Hg), 六价铬(Cr6+), 多溴联苯(PBB), 多溴联苯醚(PBDE).

有害物质指RoHS指令附件所列有害物质清单中的物质或在GB/T 26572规定的限值要求下... 2011/65/EU的范围内。

Table with columns: 产品名称: 机箱·H系列, 有害物质, 铅(Pb), 镉(Cd), 汞(Hg), 六价铬(Cr6+), 多溴联苯(PBB), 多溴联苯醚(PBDE).

NZXT does not warrant that this product will meet your requirements. It is your responsibility to determine the suitability of this product for your purposes. For NZXT Store orders, we cover two way return shipping for all exchanges and returns.

CABLE MANAGEMENT SYSTEM

SISTEMA DE GESTIÓN DE CABLES
SYSTÈME DE CÂBLAGE
KABELMANAGEMENTSYSTEM
SISTEMA DI GESTIONE DEI CAVI
SISTEMA DE GERENCIAMENTO DE CABOS
СИСТЕМА ПРОКЛАДКИ КАБЕЛЕЙ
케이블 관리 시스템
ケーブルマネジメントシステム
理线管理系统
配線管理系统

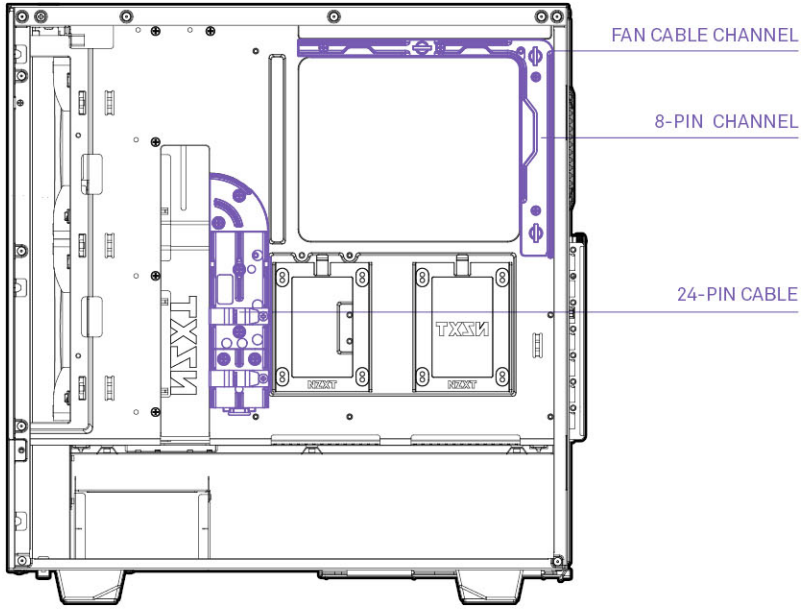

SSD DRIVE INSTALLATION

INSTALACIÓN DE LA UNIDAD DE DISCO DE ESTADO SÓLIDO
INSTALLATION DU DISQUE SSD
SSD-LAUFWERKINSTALLATION
INSTALLAZIONE DELL'UNITÀ SSD
INSTALAÇÃO DA PLACA DE EXPANSÃO
УСТАНОВКА ТРЕПЕРДОЛЬНОГО НАКОПИТЕЛЯ
SSD 安裝
SSD 安裝
SSD 安裝
SSD 安裝

VERTICAL MOUNT

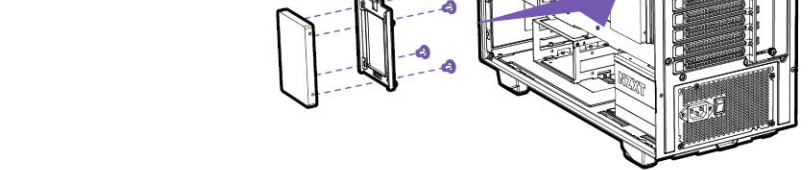

HORIZONTAL MOUNT

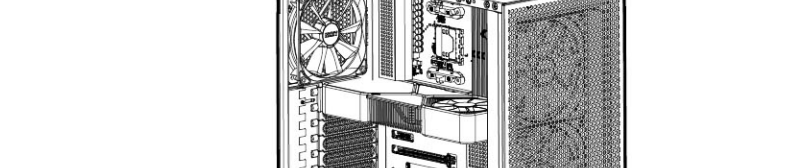

MOTHERBOARD INSTALLATION

INSTALACIÓN DE LA PLACA BASE
INSTALLATION DE LA CARTE MÈRE
INSTALLATION DER HAUPTPLATINE
INSTALLAZIONE DELLA SCHEMA MADRE
INSTALAÇÃO DA PLACA PRINCIPAL
УСТАНОВКА СИСТЕМНОЙ ПЛАТЫ
마보드 설치
マザーボードの設置
主機安裝
主機安裝

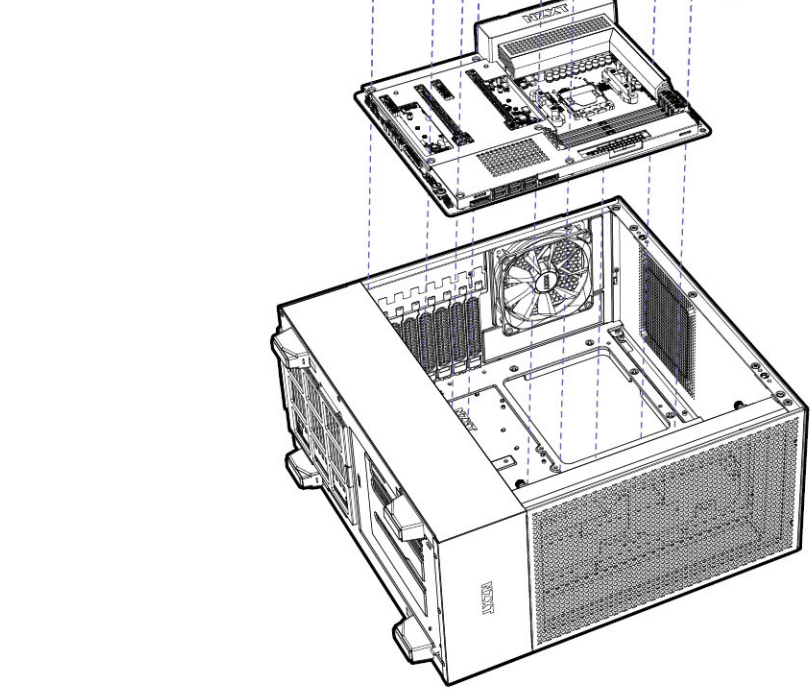

DIY LIQUID COOLER SUPPORT

HAZLO TÚ MISMO: SOPORTE PARA REFRIGERADOR LÍQUIDO
SUPPORT DE REFRIGÉREMENT LIQUIDE A ASSEMBLEURS-À-MÊME
WASSERKÜHLUNG MARKE EIGENBAU
SUPPORTO PER DISSIPATORE A LIQUIDO FAI-DA-TE
SUPPORTO A REFRIGERAÇÃO LÍQUIDA DIY
ПОДДЕРЖКА САМОСТОЯТЕЛЬНОЙ СБОРКИ ЖИДКОСТНОЙ СИСТЕМЫ ОХЛАЖДЕНИЯ
DIY 水冷散熱器
DIY 水冷散熱器
DIY 水冷散熱器
DIY 水冷散熱器

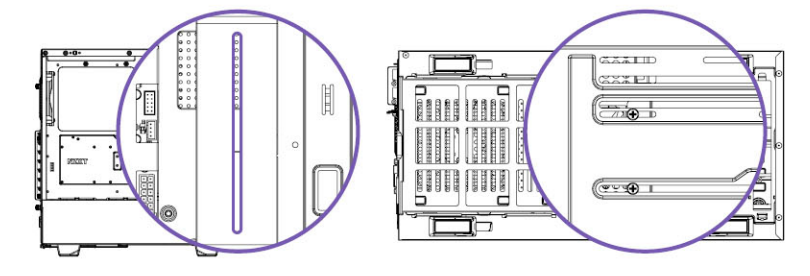

The Cable Bar could support up to 150mm tall tube reservoir with M4 screws. The bottom Panel could support D5 or DDC pump mount with M4 screws. The Cable Bar could support up to 150mm tall tube reservoir with M4 screws. The bottom Panel could support D5 or DDC pump mount with M4 screws.

POWER SUPPLY INSTALLATION

INSTALACIÓN DE LA FUENTE DE ALIMENTACIÓN
INSTALLATION DE L'ALIMENTATION
INSTALLATION DER STROMVERSORGUNG
INSTALLAZIONE DELL'ALIMENTATORE
INSTALAÇÃO DA FONTE DE ALIMENTAÇÃO
УСТАНОВКА ИСТОЧНИКА ПИТАНИЯ
전원장치 설치
電源安裝
電源安裝
電源安裝

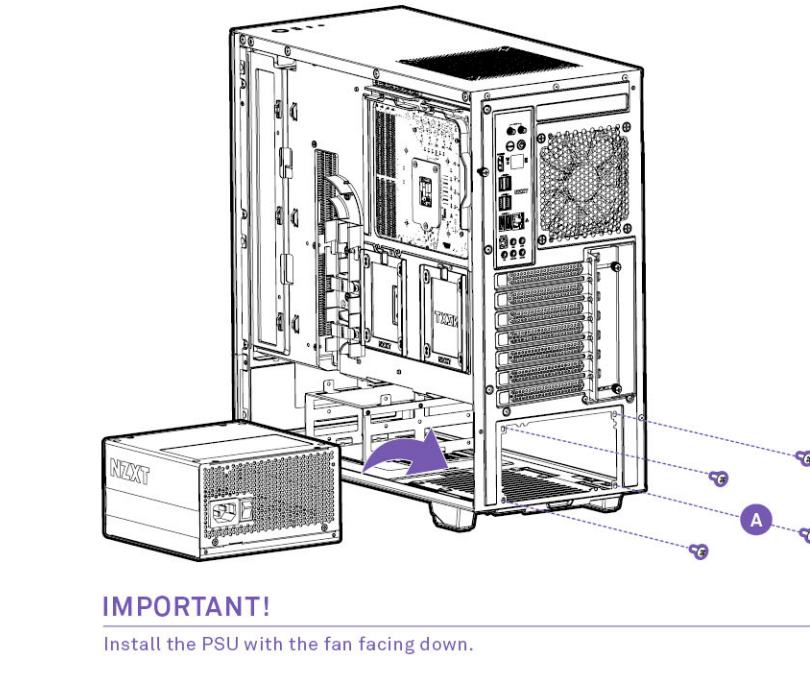

FAN AND RADIATOR SUPPORT

COMPATIBILIDAD DE VENTILADORES Y RADIADORES
SUPPORT SYSTEM: SUPPORT RADIATEURS ET VENTILATEURS
LÜFTER- UND KÜHLER-UNTERSTÜTZUNG
SUPPORTO VENTOLE E RADIATORE
SUPPORTO PARA VENTILADORA E RADIAADOR
COMPATIBILITÉ RADIAATEUR ET VENTILATEUR
風扇和散熱器支援
風扇和散熱器支援
風扇和散熱器支援

FAN MODE

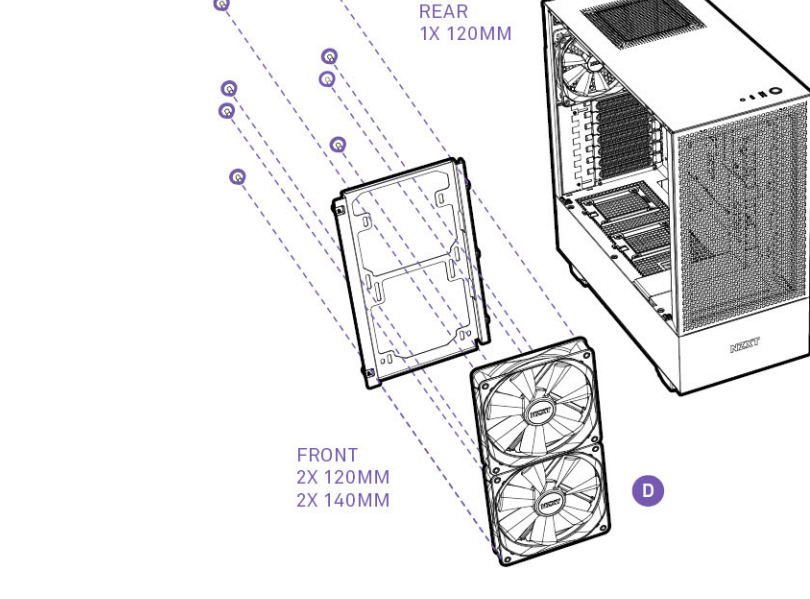

EXPANSION CARD INSTALLATION

INSTALACIÓN DE LA TARJETA DE EXPANSIÓN
INSTALLATION DE LA CARTE D'EXTENSION
INSTALLATION DER ERWEITERUNGSKARTE
INSTALLAZIONE DELLA SCHEDE D'ESPANSIONE
INSTALAÇÃO DA PLACA DE EXPANSÃO
УСТАНОВКА ПЛАТЫ РАШИРЕНИЯ
확장카드 설치
拡張カード設置
擴充卡安裝
擴充卡安裝

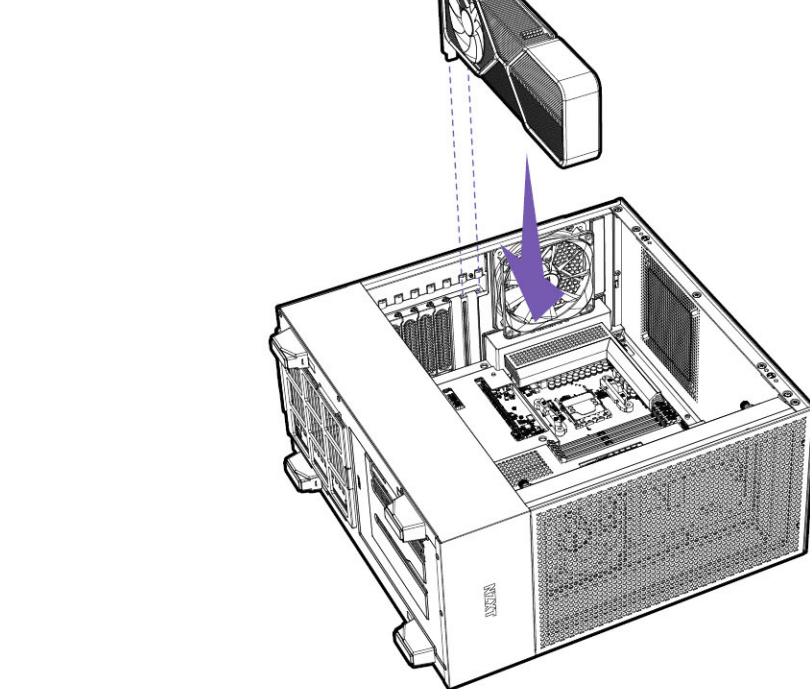

RADIATOR MODE

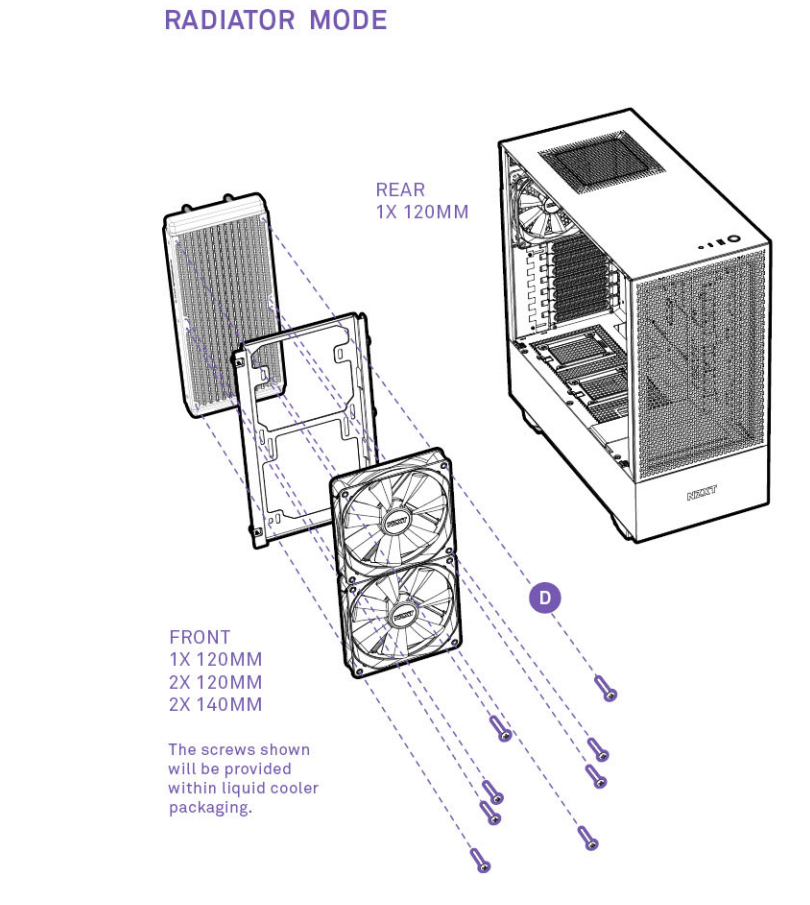

SUPPORT AND SERVICE

SUPPORT AND SERVICE
If you have any questions or problems with the NZXT product you purchased, please don't hesitate to contact us using our support system: support.nzxt.com.
Please include a detailed explanation of your problem and your proof of purchase. For comments and suggestions, you can email our design team, designer@nzxt.com.
For more information about NZXT, please visit us online: NZXT Website: nzxt.com.

지원 및 서비스
궁금한 NZXT 제품과 관련하여 질문 또는 문제가 있을 경우, 당사는 지원 시스템(support.nzxt.com)을 사용하여 문의하십시오.
문제를 자세히 기술하고 구매 증명을 제출하십시오. 의견이나 제안을 보내실 때는 support.nzxt.com에 designer@nzxt.com로 이메일을 보내십시오.
추가적으로 이 제품을 구매하신 당사자를 증명할 수 있는 검사받으십시오. NZXT에 대한 자세한 업데이트 및 관련 최신 소식은 홈페이지나, NZXT 뉴스레터를 참조하십시오.
자세한 정보는 NZXT 웹사이트: nzxt.com.
지원 및 서비스
궁금한 NZXT 제품과 관련하여 질문 또는 문제가 있을 경우, 당사는 지원 시스템(support.nzxt.com)을 사용하여 문의하십시오.
문제를 자세히 기술하고 구매 증명을 제출하십시오. 의견이나 제안을 보내실 때는 support.nzxt.com에 designer@nzxt.com로 이메일을 보내십시오.
추가적으로 이 제품을 구매하신 당사자를 증명할 수 있는 검사받으십시오. NZXT에 대한 자세한 업데이트 및 관련 최신 소식은 홈페이지나, NZXT 뉴스레터를 참조하십시오.
자세한 정보는 NZXT 웹사이트: nzxt.com.

ASSISTENZA E SERVIZIO
In caso di dubbi o problemi con il prodotto NZXT acquistato, non esitate a contattarci utilizzando il nostro sistema di assistenza: support.nzxt.com.
Includere una spiegazione dettagliata del problema e la prova di acquisto. Per commenti e suggerimenti, siete pregati di inviare un messaggio al nostro team di progettisti, all'indirizzo: designer@nzxt.com.
Per altre informazioni su NZXT, visitate il nostro sito. Sito NZXT: nzxt.com.

ASSISTÊNCIA E MANUTENÇÃO
Caso tenha questões ou problemas com o produto NZXT adquirido, não hesite em contactar-nos através do endereço service@nzxt.com fornecendo a explicação detalhada do seu problema e a prova de compra. Poderá solicitar peças de substituição através do endereço support.nzxt.com. Para comentários e sugestões, contacte a nossa equipa de design através do endereço de e-mail: designer@nzxt.com. Obrigada por ter adquirido um produto NZXT. Para mais informações acerca da NZXT, visite-nos online. Web site da NZXT: nzxt.com.

SLUŽBA PODPORKY I OSLUŽIVANÍ
V případě vznesení jakýchkoli otázek nebo neshod vznikajících při nabytí našich produktů NZXT obraťte se prosíme na adresu: service@nzxt.com a poskytněte podrobný popis problému a potvrzení nákupu.
Pro komentáře a návrhy prosíme kontaktovat naši projektovou skupinu na adrese: designer@nzxt.com.
Pokud chcete získat další informace o našem výrobku NZXT, navštívte prosíme naši webovou stránku: nzxt.com.

Scan the QR code or visit manuals.nzxt.com/h510flow to view or download the full manual.



Ovaj dokument je originalno proizveden i objavljen od strane proizvođača, brenda NZXT, i preuzet je sa njihove zvanične stranice. S obzirom na ovu činjenicu, Tehnoteka ističe da ne preuzima odgovornost za tačnost, celovitost ili pouzdanost informacija, podataka, mišljenja, saveta ili izjava sadržanih u ovom dokumentu.

Napominjemo da Tehnoteka nema ovlašćenje da izvrši bilo kakve izmene ili dopune na ovom dokumentu, stoga nismo odgovorni za eventualne greške, propuste ili netačnosti koje se mogu naći unutar njega. Tehnoteka ne odgovara za štetu nanесenu korisnicima pri upotrebi netačnih podataka. Ukoliko imate dodatna pitanja o proizvodu, ljubazno vas molimo da kontaktirate direktno proizvođača kako biste dobili sve detaljne informacije.

Za najnovije informacije o ceni, dostupnim akcijama i tehničkim karakteristikama proizvoda koji se pominje u ovom dokumentu, molimo posetite našu stranicu klikom na sledeći link:

<https://tehnoteka.rs/p/nzxt-kuciste-h510-flow-ca-h52fb-01-crno-akcija-cena/>