

## Uputstvo za upotrebu (EN)

ENERGY SISTEM bežični zvučnik FS2

ENERGY  SISTEM



Tehnoteka je online destinacija za upoređivanje cena i karakteristika bele tehnike, potrošačke elektronike i IT uređaja kod trgovinskih lanaca i internet prodavnica u Srbiji. Naša stranica vam omogućava da istražite najnovije informacije, detaljne karakteristike i konkurentne cene proizvoda.

Posetite nas i uživajte u ekskluzivnom iskustvu pametne kupovine klikom na link:

<https://tehnoteka.rs/p/energy-sistem-bezicni-zvucnik-fs2-akcija-cena/>

## ENGLISH

<b>Introduction</b> .....	3
<b>Care and maintenance</b> .....	3
<b>Technical specifications</b> .....	3
Audio .....	4
Wireless connectivity .....	4
TWS technology compatible with .....	4
Audio input .....	4
Audio output .....	4
SD and USB playback .....	4
Battery .....	4
<b>Product content</b> .....	4
<b>General overview</b> .....	4
<b>Main Functions</b> .....	5
<b>Switching on and off the device</b> .....	5
<b>Playback modes</b> .....	5
Bluetooth --> SD --> USB --> AUX .....	5
<b>Playback control</b> .....	6
<b>Bluetooth (bT)</b> .....	6
<b>True Wireless Stereo (TWS)</b> .....	6
<b>Removable USB sticks/SD cards</b> .....	6
<b>Auxiliary audio input</b> .....	7
<b>Equaliser</b> .....	8
<b>Charging the battery</b> .....	8
<b>Firmware update</b> .....	8
<b>Warranty</b> .....	8
Declaration of conformity .....	9
<b>UKCA Declaration of conformity</b> .....	10



ENERGY♥SYSTEM



# Speaker FS2.

Manual de usuario / User manual  
Manual de l'utilisateur / Manual do usuário

## Introduction

---

Thank you for trusting our company and buying the new *Speaker FS2*. We hope you enjoy it. Before you start using the device, we strongly recommend reading this manual to get used to it.

## Care and maintenance

---

- Do not expose your *Speaker FS2* to impacts, dust, humidity or high temperatures.
- Use neither corrosive nor abrasive cleaning products.
- Do not disassemble the device. All repair works should be carried out exclusively by qualified staff of Energy Sistem Technology, S.A.

## Technical specifications

---

## Audio

- System: 2.0
- Power: 12 W
- 2 full range speakers: 1.5", 6 W.
- Passive radiator: 1 diaphragm at the base.
- Frequency response: 80 Hz - 18 kHz
- Signal/Noise ratio: > 60 dB

## Wireless connectivity

- Bluetooth 5.0, class II. Up to 20 m distance range.
- Compatible Bluetooth profiles: HSP / HFP / A2DP / AVRCP
- Frequency band: 2.4 GHz (2.402 ~ 2.480 GHz)
- Maximum output power: < 20 dBm
- Hands-free function. Microphone sensitivity: -42 dB
- True Wireless Stereo (TWS) technology

## TWS technology compatible with

- Speaker FS2

## Audio input

- 3.5 mm mini jack stereo audio-in (AUX)

## Audio output

- 3.5 mm mini jack stereo audio output for headphones

## SD and USB playback

- SD and USB decoder: reads MP3 and WAV files stored on external units (up to 128 GB) with FAT/ FAT32 file system.

## Battery

- Capacity: 2000 mAh
- Type: lithium polymer
- Battery life: up to 12 hours\*
- Charging port: USB Type-C
- Charging time: 2.5 hours

## Product content

---

- Speaker FS2
- USB Type-C cable to charge the battery
- Quick guide

## General overview

---

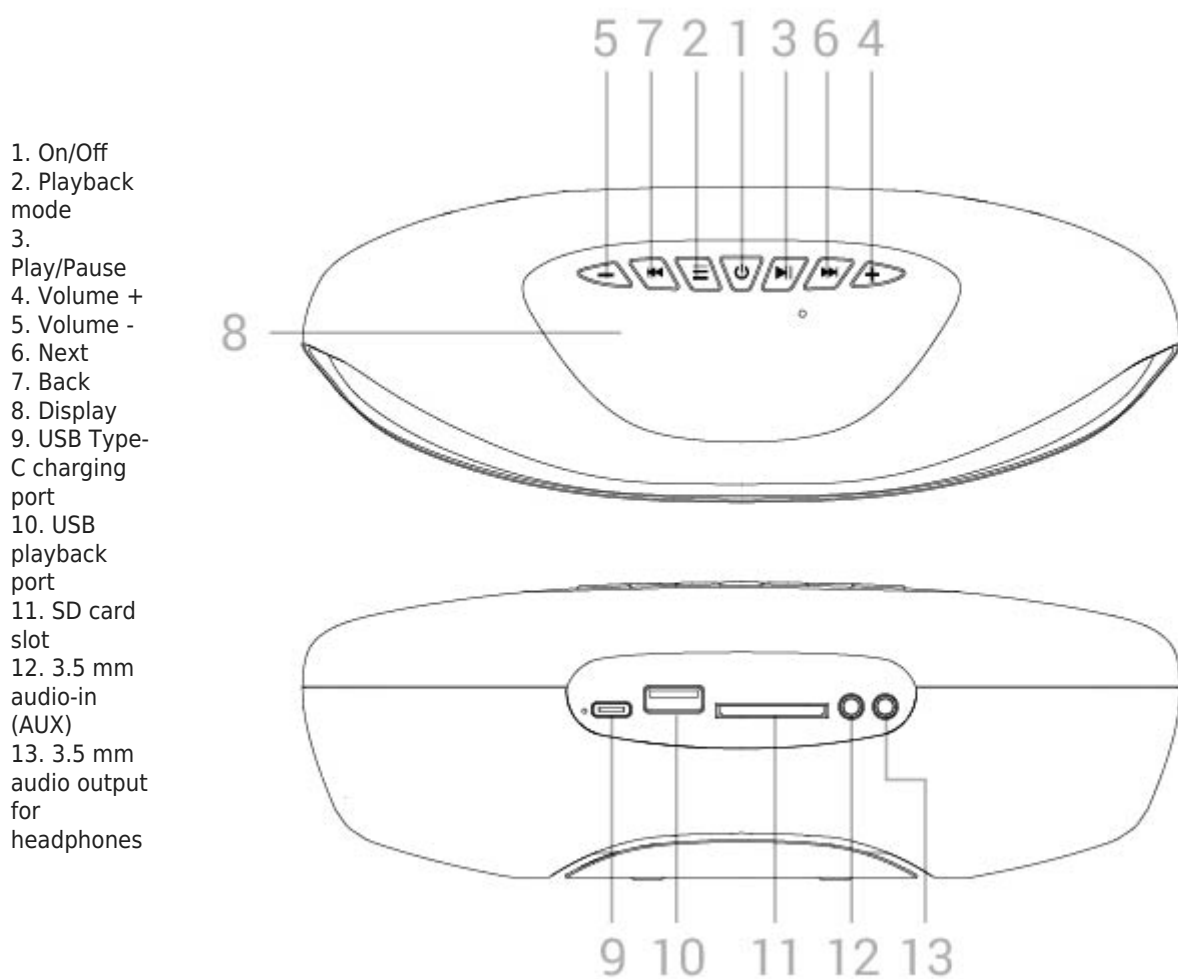

## Main Functions

### Switching on and off the device

To switch on your *Speaker FS2*, press and hold *On/Off (1)* on the top panel for 3 seconds. At this point, the *Display (8)* lights up showing the selected playback mode.

Press and hold *On/Off (1)* on the top panel for 3 seconds to switch off the device. The *Display (8)* will switch off.

**Note 1:** When switching on the device, it will always enable the last playback mode selected.

### Playback modes

Once the *Speaker FS2* is on, you can choose the playback mode you prefer. To do so, press *Playback mode (2)* repeatedly until finding the preferred playback mode. Playback modes will appear in the following order:

Bluetooth --> SD --> USB --> AUX

If you plug a removable storage unit (USB stick or SD card) or use the AUX input, your *Speaker FS2* will enable the corresponding playback mode and will play the content automatically.

## Playback control

---

Select a playback mode and you will be able to control all playback functions from your *Speaker FS2*.

Press *Play/Pause (3)* to play or pause a song.

Press *Volume - (5)* or *Volume + (4)* to adjust the volume level according to your preferences.

Press *Back (7)* or *Next (6)* to skip to the previous or next song.

**Important:** If you are using the AUX input, you will have to control playback from the connected music player.

## Bluetooth (bT)

---

To pair your speaker with a Bluetooth device, press *Playback mode (2)* until Bluetooth mode is enabled. The Bluetooth symbol (bt) will flash on the *Display (8)*.

At this point, access the Bluetooth settings on the device and search for *Energy Sistem Speaker FS2* among the detected devices. Select it to establish the connection. The devices will be connected immediately. You will hear a sound confirming both devices are correctly paired. At this point, the Bluetooth symbol (bt) is displayed permanently on the display.

Your *Speaker FS2* will automatically pair with your source device when you turn the speaker on again, provided that Bluetooth is enabled on the source device.

Press and hold *Playback mode (2)* for 2 seconds to disconnect the current device and pair the *Speaker FS2* with a new one. You will hear a sound when both devices disconnect and the Bluetooth symbol (bt) will flash on the *Display (8)*.

## True Wireless Stereo (TWS)

---

This technology allows you to wirelessly connect a second *Speaker FS2* within a maximum distance range of 20 metres to increase power and create a stereo system with separate left and right channels.

To do so, pair one speaker with your smartphone via Bluetooth first. Once you've done this, switch on the second speaker and enable Bluetooth mode.

Press and hold *Play/Pause (3)* for 2 seconds on both speakers. You will see the Bt symbol flashing quickly on both units. A few seconds later you will hear a sound to confirm both speakers have been successfully synchronized. You will hear the music through both speakers at the same time. One speaker will be assigned the left channel (L) and the other one the right channel (R).

The next time you turn on both speakers, they will pair with one another automatically.

To disable the True Wireless Stereo function, press and hold *Play/Pause (3)* for two seconds on any speaker. You will hear a confirmation sound when both units disconnect.

Skip to the next/previous track and adjust the volume from any speaker while TWS mode is enabled. If you turn up the volume on any of the speakers, you will be turning up the volume of both of them at the same time.

**Important:** This is only possible if Bluetooth mode is enabled. In all other playback modes (USB, SD or AUX-in) a TWS connection is not possible.

## Removable USB sticks/SD cards

---

Play .mp3 and .wav files from your USB sticks or SD cards (up to 128 GB). Plug the USB stick into the *USB playback port (10)* or the SD card into the *SD card slot (11)*. The speaker plays the contents automatically a few seconds after inserting the storage unit.

If you turn off your *Speaker FS2* or select another playback mode, the internal memory will save the moment where you paused playback. This way, music playback will always resume from the last track you listened to.

Press *Play/Pause* (3) to play or pause a song.

Press *Volume -* (5) or *Volume +* (4) to adjust the volume level according to your preferences.

Press *Back* (7) or *Next* (6) to skip to the previous or next song.

To select the next folder, press and hold *Playback mode* (2).

To select the preferred playback mode, press and hold *Play/Pause* (3) for 2 seconds. The information below will appear on the *Display* (8):

1) **ALL:** all USB or card contents will be repeated. The folders and files stored on your removable storage units will be read in chronological order.

2) **ONE:** the song you are listening to will be repeated.

3) **RAN:** random playback of all the contents of your removable storage unit.

4) **FOLD:** the folder with the songs you are listening to will be repeated.

The root folders and files of your removable USB sticks and SD cards will be read in chronological order and the songs included in your folders in alphabetical order.

Here you have a diagram of the reading order:

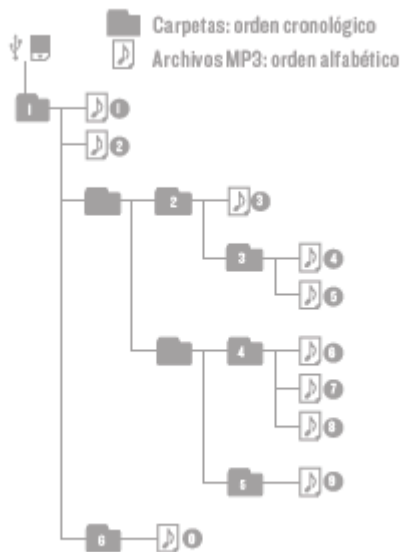

## Auxiliary audio input

Your *Speaker FS2* features a 3.5 mm *audio-in (AUX)* (12) to plug your music player using a 3.5 mm jack cable.

When using the audio-in (AUX), your *Speaker FS2* enters AUX mode automatically, thus showing it is ready to start playing content from an external device.

**Important:** If this mode is enabled, you will have to control playback from the connected music player.

## Equaliser

---

The speaker features a digital equaliser with 5 preset modes. Press quickly 2 times the *Playback mode (2)* button to select the preferred EQ mode while the device is playing music. There are 5 EQ modes available:

EQ1: Flat or flat EQ.

EQ2: Bass, EQ for an extra bass boost.

EQ3: Treble, EQ for an extra treble boost.

EQ4: Mid high, EQ for a mid boost.

EQ5: Mid low, EQ for a mid cut.

## Charging the battery

---

When the battery level is at 90% or higher, the full battery symbol appears on the *Display*. When it drops below 90%, the symbol disappears.

An empty battery symbol appears on the *Display* when the battery level drops to 10%. The symbol flashes when it drops below 5% of its capacity. You will also hear a warning sound if it drops below 2%.

To charge the battery, plug the USB Type-C end of the provided USB cable into the *USB Type-C charging port* and the other USB end to any device with a 5 V USB port (PC, USB wall charger, car charger, etc.). The LED next to the *USB Type-C charging port* glows during the charging process.

The speaker has an approximate battery life of 12 hours at 75% of volume. The battery life depends on the selected volume and the type of music.

The charging time is approximately 2 and a half hours.

### **Important:**

- Use a 5 V 2 A AC/DC power adapter.
- Do not leave your *Music Box BZ7+* completely discharged for a long time.

**Note:** The speaker will automatically reduce the volume when the battery level is low in order to protect the battery and optimize battery life.

## Firmware update

---

You can download the last firmware [here](#)

## Warranty

---

You can check the warranty terms here:

<https://www.energysistem.com/terms-warranty>

Declaration of conformity

Issuer's name: Energy Sistem Technology, S.A. - CIF: A53107488

Address: C/ Calpe, 1 - 03509 Finestrat, Alicante (Spain)

Tel: +34 966 830 324

We declare under our sole and exclusive responsibility that the product:

Description: home speaker

Brand: Energy Sistem

Model: Speaker FS2

Manufacturer: Energy Sistem Technology, S.A.

Manufacturing country: China

referred to in this declaration is in compliance with the following European Union directives:

EN 50663:2017; EN 62479:2010

EN 62368-1:2020+A11:2020

EN 301 489-17 V3.2.2 (2019-12)

EN 301 489-1 V2.2.3 (2019-11)

EN 300 328 V2.2.2 (2019-07)

EN 303 345-1 V1.1.1 (2019-06)

EN 303 345-3 V1.10 (2019-11)

in conformity with the provisions of the Directive 2014/53/EU of the European Parliament and of the Council of 16th April 2014.

Finestrat, 1st December 2020



Miguel Ángel Aragüez García

Innovation and Technology Director



## UKCA Declaration of conformity

---

Issuer's name: Energy Sistem Technology, S.A. - CIF: A53107488

Address: C/ Calpe, 1 - 03509 Finestrat, Alicante (Spain)

Tel: +34 966 830 324

We declare under our sole and exclusive responsibility that the product:

Description: home speaker

Brand: Energy Sistem

Model: Speaker FS2

Manufacturer: Energy Sistem Technology, S.A.

Manufacturing country: China

referred to in this declaration is in compliance with the essential norms and standards

BS EN 50663:2017

BS EN IEC 62368-1:2020

ETSI EN 301 489-1 V2.2.3 (2019-11)

ETSI EN 301 489-17 V3.2.4 (2020-09)

ETSI EN 300 328 V2.2.2 (2019-07)

in conformity with the provisions of the Directive UK: Radio equipment Regulations 2017.

Finestrat, 1st December 2020



Miguel Ángel Aragüez García

Innovation and Technology Director

**UK  
CA**

Ovaj dokument je originalno proizveden i objavljen od strane proizvođača, brenda Energy Sistem, i preuzet je sa njihove zvanične stranice. S obzirom na ovu činjenicu, Tehnoteka ističe da ne preuzima odgovornost za tačnost, celovitost ili pouzdanost informacija, podataka, mišljenja, saveta ili izjava sadržanih u ovom dokumentu.

Napominjemo da Tehnoteka nema ovlašćenje da izvrši bilo kakve izmene ili dopune na ovom dokumentu, stoga nismo odgovorni za eventualne greške, propuste ili netačnosti koje se mogu naći unutar njega. Tehnoteka ne odgovara za štetu nanесenu korisnicima pri upotrebi netačnih podataka. Ukoliko imate dodatna pitanja o proizvodu, ljubazno vas molimo da kontaktirate direktno proizvođača kako biste dobili sve detaljne informacije.

Za najnovije informacije o ceni, dostupnim akcijama i tehničkim karakteristikama proizvoda koji se pominje u ovom dokumentu, molimo posetite našu stranicu klikom na sledeći link:

<https://tehnoteka.rs/p/energy-sistem-bezicni-zvucnik-fs2-akcija-cena/>