

Uputstvo za upotrebu (EN)

SENCOR štapni mikser SHB 4460WH-EUE3

SENCOR



Tehnoteka je online destinacija za upoređivanje cena i karakteristika bele tehnike, potrošačke elektronike i IT uređaja kod trgovinskih lanaca i internet prodavnica u Srbiji. Naša stranica vam omogućava da istražite najnovije informacije, detaljne karakteristike i konkurentne cene proizvoda.

Posetite nas i uživajte u ekskluzivnom iskustvu pametne kupovine klikom na link:

<https://tehnoteka.rs/p/sencor-stapni-mikser-shb-4460wh-eue3-akcija-cena/>

SENCOR®

SHB 4460WH / SHB 4461GR
SHB 4462BL / SHB 4463OR
SHB 4464RD / SHB 4465VT
SHB 4466YL / SHB 4467TQ
SHB 4468RS



EN ■ Stick blender

Translation of the original manual

READ CAREFULLY AND STORE FOR FUTURE USE.**General warnings**

- This appliance may not be used by children. Keep the appliance and its power cord away from children.
- These appliances may be used by persons with reduced physical, sensory or mental capabilities or with a lack of experience and knowledge, if they are supervised or have been instructed to use the appliance in a safe manner and understand the potential dangers.
- Cleaning and maintenance performed by the user must not be performed by unsupervised children.
- In the event that the power cord is damaged, have it repaired at a professional service centre to prevent causing a dangerous situation. It is forbidden to use the appliance if it has a damaged power cord.

**Warning:**

Incorrect use may lead to injuries.

- Be especially careful not to injure yourself on the sharp cutting edges when handling the chopping blades, especially when removing the blades from the blending jar, when emptying the container and when cleaning it.
- The surfaces of the appliance that come into contact with food must always be cleaned according to the instructions in this user's manual.
- Always turn off the appliance and disconnect it from the power socket if you will not be using it and if you will be leaving it without supervision, before assembly, disassembly, cleaning or moving it.
- Before replacing the accessories or accessible parts that move during use, turn the appliance off and disconnect it from the power supply.
- Children must not play with the appliance.

Electrical safety

- Before connecting this appliance to a power socket, make sure that the voltage stated on its rating label corresponds to the voltage in your power socket
- Connect the appliance only to a properly grounded socket. Do not use an extension cord.

- Never connect the appliance to a power socket until it is properly assembled.
- Fully unwind the power cord before using it.
- Do not connect and disconnect the power cord to and from the power socket with wet hands.
- Ensure that the power plug contacts do not come into contact with water or any other liquid. If precisely this happens, carefully dry the power plug before using it again.
- Do not disconnect the appliance from the power socket by pulling on the power cord. This could damage the power cord or the power socket. Disconnect the power cord from the power socket by pulling on the plug.
- Do not place heavy items on the power cord. Make sure the power cord does not hang over the edge of a table or that it is not touching a hot surface or sharp objects.
- Do not wind the power cord around the appliance.
- To avoid the danger of injury by electrical shock, do not repair the appliance yourself or make any adjustments to it. Have all repairs or adjustments of the appliance performed at an authorised service centre. Tampering with the appliance during the warranty period may void the warranty.
- To prevent the risk of injury by electrical shock, never submerge the motor unit and its power cord in water or any other liquid, or wash these parts under running water.
- Always turn off the appliance and disconnect it from the power socket when you have finished using it.
- In the event that the appliance falls into water, under no condition reach for it, rather, immediately disconnect the power cord from the power socket. Never use an appliance that was submerged in water. Hand it over to an authorised service centre for inspection.

Safety during use

- This appliance is designed for household and is intended for blending, chopping and whipping food. It is also suitable for processing hard ingredients such as coffee beans, cocoa beans, ice cubes, nutmeg, etc.
- Do not use the appliance in an industrial environment or outdoors. Do not use it for any other purposes than those for which it is intended.
- The appliance is intended for domestic use and similar locations such as:
 - kitchens in stores; offices and other workplaces;
 - in agriculture;
 - for guests of hotels, motels and other similar locations;
 - in bed and breakfast establishments.
- This appliance is not intended to be operated using an external timer switch or a remote control system.

- Use the appliance and its accessories in accordance with the instructions contained in this user's manual.
- Only use the appliance with the original accessories that came with it.
- Before every use, check the selected accessory for damage. Never use the appliance with a damaged accessory.
- Do not place the appliance or its accessories on an electric or gas stove or in its vicinity, on the edge of a table or on an unstable surface. Only place the appliance on an even, dry and stable surface.
- Do not expose the appliance and its accessories to the outdoor environment, extreme temperatures, direct sunlight, excessive humidity or excessively dusty environments.
- Do not place the appliance and its accessories near heaters, open fires or other sources of heat.
- Make sure that the appliance is correctly assembled before putting it into operation.
- Do not touch moving rotating parts during operation. Otherwise, this could result in injury.
- Be especially careful when handling hot liquids and foods. Hot steam or splashing hot foods and liquids may cause scalding. For reasons of increased safety, allow hot foods and liquids to cool down to at least 45 °C before blending.
- The operating time of the appliance is 1 minute. Before turning it on again, allow it to cool down for at least 3 to 5 minutes. When using the appliance to blend sticky or harder foodstuffs, interrupt operation already after 30 seconds.
- Do not turn on the appliance when it is empty. Incorrect use of the appliance may negatively affect its lifetime.
- Check that the motor unit is turned off, disconnected from the power socket and that the rotating parts have come to a complete stop before disassembling the appliance into its individual parts.
- Do not perform any maintenance on the appliance other than cleaning the individual components as described in chapter Cleaning and maintenance.
- Never use an appliance that is damaged in any way.
- Do not use the appliance if it has fallen on the floor, if it was submerged in water, if it is not functioning correctly or if it is damaged in any other way.
- When handling the blade assembly of the blender or chopper unit, especially when taking the blade assembly out of the bowl, when emptying the bowl and cleaning it, take special care to avoid injury by the blades.
- Do not use the appliance when it is not functioning properly or showing signs of damage.

- In order to prevent a hazardous situation arising, do not repair the appliance yourself or modify it in any way. Have all repairs performed at an authorised service centre. By tampering with the appliance, you risk voiding your legal rights arising from unsatisfactory performance or quality warranty.
- Store the appliance in a dry environment.

A

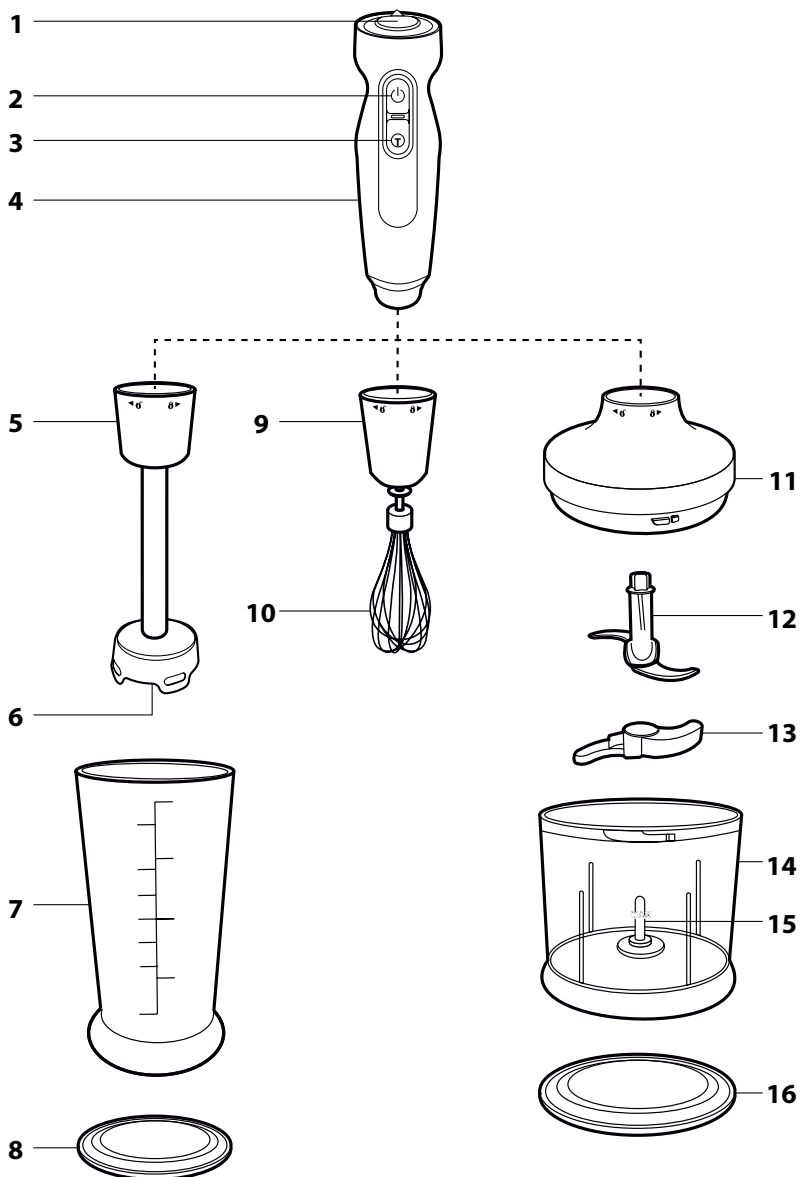

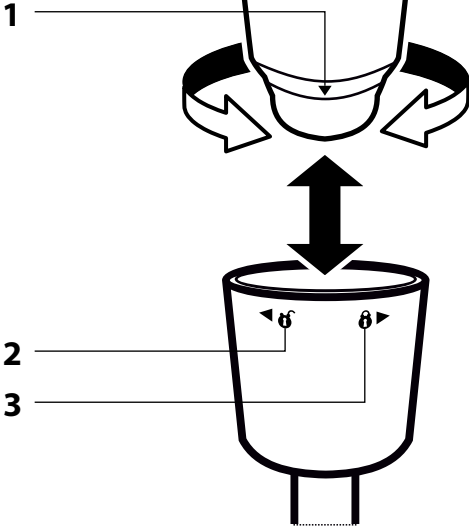
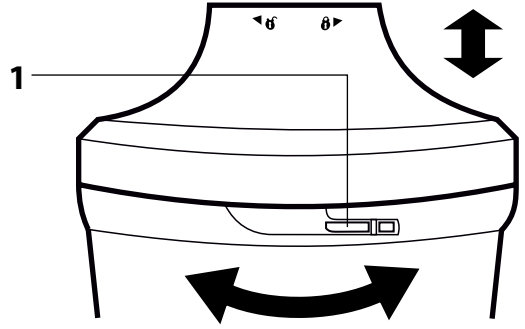
B**C**

- Prior to using this appliance, please read the user's manual thoroughly, even in cases, when one has already familiarised themselves with previous use of similar types of appliances. Only use the appliance in the manner described in this user's manual. Keep this user's manual in a safe place where it can be easily retrieved for future use. In the event that you hand this appliance over to somebody else, make sure to also include this user's manual.
- Carefully unpack the appliance and take care not to throw away any part of the packaging before you find all its parts. We recommend saving the original cardboard box, packaging material, purchase receipt and responsibility statement of the vendor or warranty card for at least the duration of the legal liability for unsatisfactory performance or quality. In the event of transportation, we recommend that you pack the appliance in the original box from the manufacturer.

DESCRIPTION OF THE APPLIANCE AND ITS ACCESSORIES

A1 Speed control dial	A11 Chopper bowl lid with gear system
A2 Normal speed switch	A12 Chopper with blade assembly
A3 High speed switch (turbo)	A13 Protective cover
A4 Motor unit	A14 Chopper bowl, volume 500 ml
A5 Removable blender stick attachment	A15 Shaft
A6 Blade assembly It contains titanium-coated stainless steel blades	A16 Anti-slip base pad
A7 Beaker, volume 700 ml	B1 Help arrow
A8 Anti-slip base pad / lid	B2 "Unlocked" symbol
A9 Whisk attachment with gear system	B3 "Locked" symbol
A10 Whisk	C1 Locking tabs

PURPOSE OF USE

STICK BLENDER ATTACHMENT

- It is suitable for blending soft ingredients and liquids. It is used namely for preparing baby food, various types of milkshakes, sauces, spreads, etc.

WHISK

- The whisk is suitable for preparing light batters or for whipping cream, egg whites, dessert creams, liquid sponge cake doughs, mayonnaise, etc. Do not use it to whip thick doughs.

CHOPPER

- It is suitable for chopping tougher foods such as meat, semi-hard or hard cheese, fruit and vegetables in their raw state, nuts, herbs, etc. Thanks to its special tabs, it is also suitable for chopping harder foods such as ice cubes, coffee beans, nutmeg, cocoa beans.

BEFORE FIRST USE

- Thoroughly wash all removable accessories that are intended to come into contact with food using warm water and a neutral kitchen detergent. Then rinse them with clean water and allow them to dry naturally or wipe them thoroughly dry using a fine wiping cloth.
- Clean parts **A9** and **A11**, which are equipped with a gear system, only using a dampened cloth. Take care that water does not enter into these parts.



Attention:

When cleaning blade assemblies **A6** and **A12**, be very careful not to injure yourself on their sharp edges.

- When cleaning the stick blender attachment **A5**, do not submerge the top end that connects to the motor unit **A4**.

ATTACHING AND REMOVING BLENDING AND WHIPPING ATTACHMENTS



Attention:

Before attaching or removing attachments **A5** or **A9**, make sure that the motor unit **A4** is turned off and disconnected from the power socket and that the rotating parts have come to a complete stop. The parts of the attachments that are connected to the motor unit, must be thoroughly dry.

- Depending on the activity, select attachment **A5** or **A9**. Slide the selected attachment on to the motor unit **A4** from underneath so that the arrow **B1** on the rear side of the motor unit points at the unlocked padlock symbol **B2** on the attachment.
- Turn the motor unit so that the arrow moves to the locked padlock symbol **B3**. The connection of both parts is accompanied by a click.
- To release the attachment from the motor unit, firmly grasp both parts and turn the motor unit so that the arrow points at the open padlock symbol. Pull both parts away from each other.

ASSEMBLING AND DISASSEMBLING THE CHOPPER

- Place the bowl **A14** on an even and stable surface. Remove the protective cover **A13** from the chopper **A12**, and seat the chopper on the central shaft **A15** on the bottom of the bowl.
- Put the lid **A11** on to the bowl so that the shaft of the chopper **A12** slides into the central part of the lid so that the locking tabs **C1** along the sides of the lid fit into the grooves in the bowl. Turn the lid so that the tabs on the lid slide into the grooves. Correctly securing the lid is accompanied by a click.
- Attach the motor unit **A4** to the lid **A11** following the same procedure as described in chapter Attaching and removing attachments.
- To remove them proceed in the reverse sequence to their assembly.

OPERATING THE APPLIANCE

- Select the type of accessories that you wish to use, and assemble the appliance according to the instructions in the preceding chapters.
- For blending, use the beaker **A7** or another suitable container intended for coming into contact with food. The anti-slip base pad **A8** also serves as a lid for the beaker, when you wish to use it for short term storage of food.
- Do not overfill the beaker **A7** and bowl **A14** past the maximum level marks. This will prevent splattering the ingredients while they are processed.
- When assembling the chopper, place the food into the bowl **A14** only after placing the chopper **A12**, be on to the central shaft **A15** at the bottom of the bowl. Do not fill the bowl past the maximum level mark (MAX).

- Connect the motor unit **A4** to a power socket. Set the required speed using the speed control dial **A1**. Turn the speed control dial clockwise to increase the speed, and anticlockwise to reduce the speed. The speed can also be adjusted while the appliance is running. However, speed can only be adjusted when using normal speed. It cannot be adjusted at high speed.
- After setting the speed, hold down switch **A2** or **A3**. The appliance will run as long as the switch is held down. Releasing the switch will turn off the appliance.



Attention:

The maximum continuous operating time of the appliance is 1 minute. Then allow it to cool down for 3 to 5 minutes. When using the appliance to blend sticky or harder foodstuffs, interrupt operation already after 30 seconds.

- After you finish using it, disconnect the power cord from the power socket. Make sure that the rotating parts have stopped rotating, and disassemble the appliance into its individual parts. Then clean all used parts according to the instructions in chapter Cleaning and maintenance.

ADVICE AND TIPS

- When using the blender attachment, it is recommended to always blend at a lower speed. While blending, move the blender up and down to blend the ingredients to the required consistency.
- To prevent ingredients from splattering, put the blender attachment **A5** or the whisk **A9** into the beaker containing the ingredients before starting it, and conversely turn it off before pulling the attachment out of the beaker.
- To prevent ingredients from splattering, keep the blade assembly **A6** of the blending attachment and whisk **A10** submerged while the appliance is running. It is recommended to divide a larger amount of processed ingredients into several batches and to regularly inspect the contents inside the beaker.
- When using the blender or chopper attachment, it is recommended to process ingredients using short pulses. This will prevent the ingredients from being excessively pulverised and optimal results will be achieved.
- To make blending and chopping easier, cut hard ingredients into small pieces.
- To achieve better blending results, hold the stick blender slightly tilted, while carefully moving it up and down in the beaker. Do not use force to push ingredients down with the stick blender.
- Before blending or chopping, remove hard parts such as fruit stones or bones from the blended ingredients. This will prevent damaging the blade assembly.

QUICK GUIDE TO PROCESSING INGREDIENTS

- The food processing times provided below are only a reference. The actual processing time depends on the size of the ingredients, their amount and the required final consistency. If the required consistency is not achieved during the maximum operating time of the appliance, you may continue processing the food after the appliance has cooled down.

STICK BLENDER

INGREDIENTS	AMOUNT	SPEED SETTING	PROCESSING TIME
Baby food	300 g	Medium to maximum	45 s
Spreads	200 g	Medium to maximum	30 s
Fruit and vegetables (cooked)	200 g	Medium to maximum	45 s
Sauces	500 ml	Medium to maximum	45 s
Shakes	500 ml	Medium to maximum	30 s

CHOPPER

INGREDIENTS	AMOUNT	SPEED SETTING	PROCESSING TIME
Meat	300 g	Medium to maximum	30 s
Fruit and vegetables	200 g	Medium to maximum	15 s
Hard and semi-hard cheeses	150 g	Maximum	10 s
Hard baked goods	100 g	Medium to maximum	20 s
Nuts with shells removed	100 g	Maximum	15 s
Herbs	50 g	Medium	10 s

- First, cut up the food into cubes of approximately 2 x 2 cm and only then process with the chopper. With vegetables like onion, it is sufficient to cut them into quarters.

WHIPPING

INGREDIENTS	AMOUNT	SPEED SETTING	PROCESSING TIME
Egg whites	4 pcs	Maximum	60 s
Whipping cream	200 ml	Maximum	60 s
Light doughs	500 g	Medium to maximum	60 s

- Always whip cream and egg whites in a tall narrow beaker. When whipping egg whites, the whisks **A8** and the beaker must always be perfectly clean and dry, otherwise whipping up the egg whites may not succeed.

CLEANING AND MAINTENANCE

- Before cleaning it, make sure that the appliance is turned off, disconnected from the power socket and that the rotating parts have stopped.
- Disassemble the appliance into its individual parts. Thoroughly wash the attachments and containers, using warm water and neutral kitchen detergent. Then rinse them with clean water and allow them to dry naturally or dry them out thoroughly using a wiping cloth.
- Clean parts **A9** and **A11**, which are equipped with a gear system, only using a dampened cloth. Take care that water does not enter into these parts.
- When cleaning the blender attachment **A5**, do not submerge the top end that connects to the motor unit **A4**.
- The beaker **A7** and bowl **A14**, the anti-slip base pad **A8** and the blade assembly **A12** can be washed in a dishwasher. Other parts are not intended for washing in a dishwasher.



Attention:

When cleaning blade assemblies **A6** and **A12**, be very careful not to injure yourself on their sharp edges.

- After finishing using the stick blender, it is possible to clean the blade assembly **A6** by submerging it in warm water with kitchen detergent, and running it for a short time. Then disconnect the appliance from the power socket, disassemble it, and rinse the blade assembly with clean drinking water and dry it thoroughly.
- To clean the outer surface of the motor unit **A4**, use a cloth lightly dipped in a weak detergent solution. After applying the detergent solution, wipe the surface with a cloth lightly dampened in clean water and then wipe dry. Do not use solvents, abrasive cleaning products, etc. for cleaning the appliance. Otherwise the surface coat of the appliance may be damaged.



Attention:

Never submerge the motor unit **A4** or the power cord in water or in any other liquid.

STORAGE

- When you have finished using the appliance, place it and its accessories in a clean, dry place out of children's reach. Keep the stored appliance and its accessories away from extreme temperatures, direct sunlight and excessive humidity and do not store it in an overly dusty environment.

TECHNICAL SPECIFICATIONS

Rated voltage range	220–240 V
Rated frequency	50/60 Hz
Rated power input	1000 W
Electrical shock protection class	II
Noise level	85 dB(A)

The declared noise emission level of the appliance is 85 dB(A), which represents a level A of acoustic power with respect to a reference acoustic power of 1 pW.

EXPLANATION OF TECHNICAL TERMINOLOGY

Safety class for electrical shock protection:

Class II – Electrical shock protection is provided by double or heavy-duty insulation.

Amendments to text and technical parameters are reserved.

INSTRUCTIONS AND INFORMATION REGARDING THE DISPOSAL OF USED PACKAGING MATERIALS

Take the packaging material to a designated municipal waste facility.

DISPOSAL OF USED ELECTRICAL AND ELECTRONIC EQUIPMENT



This symbol on products or original documents means that used electric or electronic products must not be thrown out with ordinary municipal waste. For proper disposal and recycling, take these products to designated collection points. Alternatively, in some European Union states or other European countries you may return your appliances to the local retailer when buying an equivalent new appliance. Correct disposal of this product helps save valuable natural resources and prevents damage to the environment caused by improper waste disposal. Ask your local authorities or collection facility for more details. In accordance with national regulations penalties may be imposed for the incorrect disposal of this type of waste.

For business entities in European Union states

If you want to dispose of electric or electronic appliances, ask your vendor or supplier for the necessary information.

Disposal in other countries outside the European Union.

This symbol is valid in the European Union. If you wish to dispose of this product, request the necessary information about the correct disposal method from the local council or from your vendor.



This product meets all the basic requirements of EU directives related to it.

Ovaj dokument je originalno proizveden i objavljen od strane proizvođača, brenda Sencor, i preuzet je sa njihove zvanične stranice. S obzirom na ovu činjenicu, Tehnoteka ističe da ne preuzima odgovornost za tačnost, celovitost ili pouzdanost informacija, podataka, mišljenja, saveta ili izjava sadržanih u ovom dokumentu.

Napominjemo da Tehnoteka nema ovlašćenje da izvrši bilo kakve izmene ili dopune na ovom dokumentu, stoga nismo odgovorni za eventualne greške, propuste ili netačnosti koje se mogu naći unutar njega. Tehnoteka ne odgovara za štetu nanесenu korisnicima pri upotrebi netačnih podataka. Ukoliko imate dodatna pitanja o proizvodu, ljubazno vas molimo da kontaktirate direktno proizvođača kako biste dobili sve detaljne informacije.

Za najnovije informacije o ceni, dostupnim akcijama i tehničkim karakteristikama proizvoda koji se pominje u ovom dokumentu, molimo posetite našu stranicu klikom na sledeći link:

<https://tehnoteka.rs/p/sencor-stapni-mikser-shb-4460wh-eue3-akcija-cena/>