

Uputstvo za upotrebu (EN)

SENCOR mikser sa posudom STM 3751GR-EUE3

SENCOR



Tehnoteka je online destinacija za upoređivanje cena i karakteristika bele tehnike, potrošačke elektronike i IT uređaja kod trgovinskih lanaca i internet prodavnica u Srbiji. Naša stranica vam omogućava da istražite najnovije informacije, detaljne karakteristike i konkurentne cene proizvoda.

Posetite nas i uživajte u ekskluzivnom iskustvu pametne kupovine klikom na link:

<https://tehnoteka.rs/p/sencor-mikser-sa-posudom-stm-3751gr-eue3-akcija-cena/>

SENCOR®

STM 3750WH / STM 3751GR / STM 3725BL
STM 3753OR / STM 3754RD / STM 3755VT
STM 3756YL / STM 3757TQ / STM 3758RS



EN ■ Stand mixer

Translation of the original manual

READ CAREFULLY AND STORE FOR FUTURE USE.

General warnings

- This appliance may not be used by children. Keep the appliance and its power cord away from children.
- These appliances may be used by persons with reduced physical, sensory or mental capabilities or with a lack of experience and knowledge, if they are supervised or have been instructed to use the appliance in a safe manner and understand the potential dangers.
- Cleaning and maintenance performed by the user must not be performed by unsupervised children.
- In the event that the power cord is damaged, have it repaired at a professional service centre to prevent causing a dangerous situation. It is forbidden to use the appliance if it has a damaged power cord.



Warning:

Incorrect use may lead to injuries.

- Be especially careful not to injure yourself on the sharp cutting edges when handling the chopping blades, especially when removing the blades from the blending jar, when emptying the container and when cleaning it.
- The surfaces of the appliance that come into contact with food must always be cleaned according to the instructions in this user's manual.
- Always turn off the appliance and disconnect it from the power socket if you will not be using it and if you will be leaving it without supervision, before assembly, disassembly, cleaning or moving it.
- Before replacing the accessories or accessible parts that move during use, turn the appliance off and disconnect it from the power supply.
- Children must not play with the appliance.

Electrical safety

- Ensure that the power plug contacts do not come into contact with water or moisture.
- Do not place heavy items on the power cord. Make sure the power cord does not hang over the edge of a table or that it is not touching a hot surface or sharp objects, and keep it away from the rotating parts of the appliance.

- Do not disconnect the appliance from the power socket by pulling on the power cord. This could damage the power cord or the power socket. Disconnect the cord from the power socket by gently pulling the plug of the power cord.
- To avoid the danger of injury by electrical shock, do not repair the appliance yourself or make any adjustments to it. Have all repairs or adjustments of the appliance performed at an authorised service centre. Tampering with the appliance during the warranty period may void the warranty.
- Connect the appliance only to a properly grounded socket. Do not use an extension cord.
- Never connect the appliance to a power socket until it is properly assembled.
- Always turn off the appliance and disconnect it from the power socket when leaving it without supervision, before assembly, disassembly, and after you have finished using it.

Safety during use

- This appliance may not be used by children. Keep the appliance and its power cord away from children.
- Never use accessories, which have not been supplied with this appliance or which have not been explicitly recommended by the manufacturer.
- The appliance is intended and designed for processing a standard amount of food in the household.
- This appliance is designed for use in locations such as:
 - staff kitchens in stores, offices and other workplaces;
 - agricultural farms;
 - hotel or motel rooms and other living areas;
 - bed and breakfast establishments.
- Do not use the appliance for any other purposes than those intended.
- Do not use the appliance in an industrial environment or outdoors.
- Do not use sprays in the vicinity of the appliance.
- Only position the appliance on a clean, dry, horizontal and stable surface. Do not use it on the drainboard of a kitchen sink.
- Do not position the appliance on the edge of a kitchen countertop or table, on window sills or unstable surfaces.
- Do not place the appliance on an electric or gas stove, in the vicinity of an open flame or appliances that are sources of heat.
- Do not wash the appliance (except for the removable attachments and mixing bowl) under running water and do not submerge it in water or any other liquid.
- Before attaching attachments to the appliance, removing or replacing them, ensure that the appliance is turned off and disconnected from the power socket.
- For safety reasons, this appliance is equipped with a safety mechanism that prevents the motor from being started if the appliance's arm is tilted out.

- Before putting the appliance into operation, check that it is correctly assembled and that the arm is in the horizontal position.
- Hot liquids up to a temperature of 80 °C may be processed in the blending jar. Be especially careful when handling hot liquids. Hot steam or splashing hot foods and liquids may cause scalding. Never start the blender without the lid properly seated in position. When processing hot liquids, do not remove the inner cap during operation. Do not touch the hot surface. Use the handle to carry the blending jar when it is hot.
- Do not attempt to grind bones, nut shells or other hard ingredients.
- When kneading, beating or whipping, do not leave the appliance in continuous operation under a heavy load for longer than 6 minutes. Do not leave the blender running for longer than 1 minute. In both cases, allow the appliance to cool down for at least 10 minutes.
- When beating, kneading or blending, do not tilt out the arm or put your hands or items, such as a kitchen knife, fork or wooden spoon, into the stainless steel bowl. Do not touch the rotating attachments and ensure that foreign items such as clothing, hair, etc. are kept away. An injury could occur or the appliance could be damaged.
- If an item, such as a spoon, falls into the mixing bowl while the appliance is running, immediately set the speed control knob to position 0 (stand-by mode), disconnect the power cord from the power socket and take the item out of the bowl.
- If ingredients stick to the attachments or the inside of the bowl, turn off the appliance and disconnect it from the power socket. Use a spatula to clean the attachments and the inside of the bowl. Then you can continue mixing.
- Do not turn the appliance on when empty. The incorrect use of the appliance may negatively affect its lifetime.
- Before storing the appliance, check that the stand arm is tilted to the horizontal position.
- Do not place any items on to the appliance. Do not insert any objects into the ventilation openings of the appliance.
- Do not put the accessories of the appliance into a microwave oven.
- Be very careful when there is a hot liquid inside the bowl because the hot liquid may splash out of the appliance as a result of a sudden release of steam.
- Never process boiling liquids.
- When filling the stainless steel bowl, do not exceed the maximum capacity level marked on it.
- Always turn off the appliance by setting the speed control knob to position 0 (stand-by mode). After turning it off, always wait until the moving parts come to a complete stop, and then disconnect it from the power socket before tilting open the head, before opening or removing any attachments

A

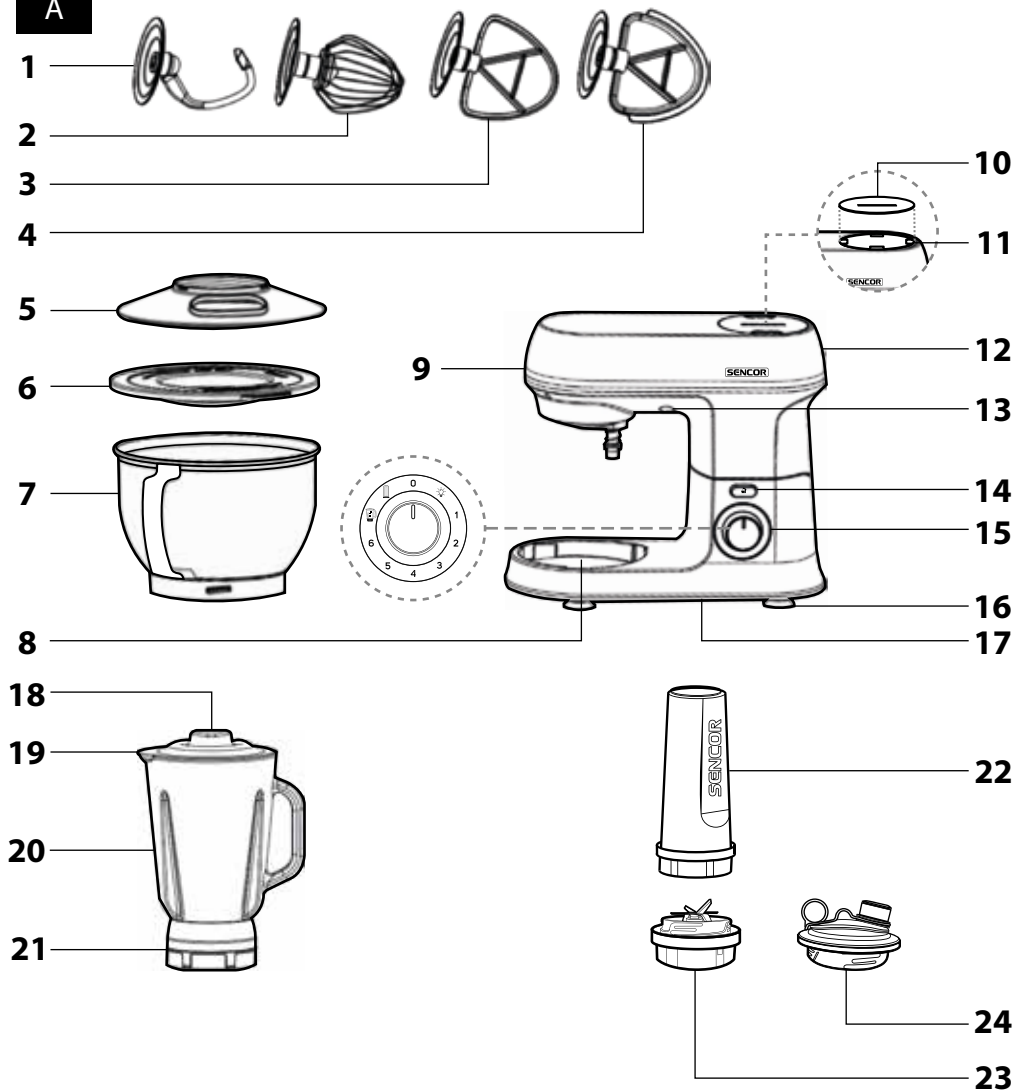

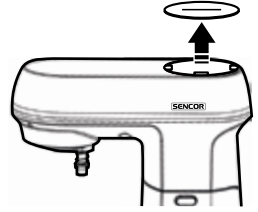
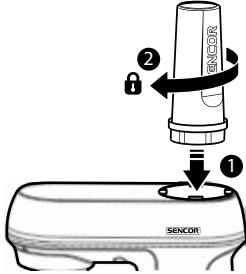
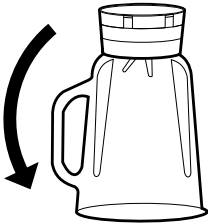
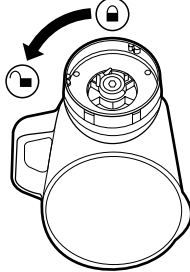
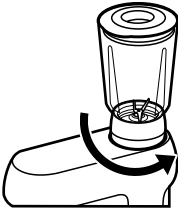
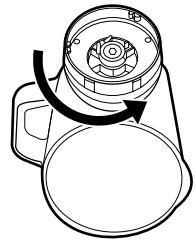
B**1****2****3****4****5****C****1****2****3****4****5****6**

DESCRIPTION OF THE APPLIANCE AND ACCESSORIES

- A1** Kneading hook
- A2** Elastic balloon whisk
- A3** A-shaped beater
- A4** Elastic A-shaped beater
- A5** Anti-splash transparent lid
- A6** Bowl lid
- A7** 4-litre stainless steel bowl
- A8** Base unit
- A9** Mixing head with shaft for mounting attachments **A1**, **A2**, **A3** or **A4**
- A10** Top removable lid
- A11** Hub for the blender
- A12** Tilt-out arm with open position lock
- A13** LED illumination
- A14** PUSH button for releasing the arm
- A15** Illuminated speed control knob
 - 0 (turned off to stand-by mode)
 - speed level setting 1, 2, 3, 4, 5, 6 (52, 87, 112, 122, 136 and 172 rpm)



- blending mode



- smoothie mode

- A16** Anti-slip feet with suction cups
- A17** Compartment for winding up the power cord
- A18** Inner cap
- A19** Outer lid
- A20** Blending jar with 1.5 l capacity
- A21** Removable blade assembly
- A22** 0.6-litre nutri-bottle
It is made from very durable Tritan plastic.
- A23** Removable blade assembly with titanium-coated chopping blades
- A24** Lid with a closable drinking spout

BEFORE FIRST USE

- Prior to using this appliance, please read the user's manual thoroughly, even in cases, when one has already familiarised themselves with previous use of similar types of appliances. Only use the appliance in the manner described in this user's manual. Keep this user's manual in a safe place where it can be easily retrieved for future use. In the event that you hand this appliance over to somebody else, make sure to also include this user's manual.
- We recommend saving the original cardboard box, packaging material, purchase receipt and responsibility statement of the vendor or warranty card for at least the duration of the legal liability for unsatisfactory performance or quality. In the event of transportation, we recommend that you pack the appliance in the original box from the manufacturer.

1. Carefully unpack the appliance and take care not to throw away any part of the packaging before you find all the parts of the appliance.
2. Thoroughly all parts (kneading hook **A1**, elastic balloon whisk **A2**, A-shaped beater **A3**, elastic A-shaped beater **A4**, lid **A5**, **A6**, stainless steel mixing bowl **A7**, blending jar **A20** with lids **A18** and **A19**, nutri- bottle **A22** lid **A24** and both blade assemblies **A21** and **A23**), that are intended to come into contact with food using warm water and a neutral kitchen detergent. Then rinse them with clean water and dry them thoroughly with a fine wiping cloth.



Attention:

When cleaning blade assemblies **A21** and **A23**, take special care to avoid injury on the sharp cutting edges.

BEATING, WHIPPING AND KNEADING

PLANETARY MIXING SYSTEM

- The planetary mixing system is based on the principle of dual rotation of the attachment. The attachment rotates anticlockwise along the inner perimeter of the bowl while rotating around its own axis in the opposite direction. This ensures that ingredients inside the bowl are processed thoroughly and evenly.

SELECTING ATTACHMENT TYPES

ATTACHMENT TYPE	PURPOSE OF USE
Kneading hook A1	It is used for kneading and preparing heavy and thick doughs containing yeast, e.g. bread dough.
A-shaped beater A3 and elastic A-shaped beater A4	It is used for mixing medium heavy and lighter doughs not containing yeast, for mixing sauces, creams, fillings, etc.
Balloon whisk A2	It is used for whisking whole eggs or egg whites, whipped cream, light doughs, foamy creams, etc. Do not use it for mixing heavy and thick doughs.

ASSEMBLY AND DISASSEMBLY

- Before you start assembling or disassembling the food processor, check that it is turned off and disconnected from the el. power socket.

1. Inserting the mixing bowl

- 1.1 Place the food processor on an even, dry surface, for example on a kitchen countertop.
- 1.2 Release the arm **A12** by pressing the PUSH button **A14** and tilt it upwards. The arm is locked in the open position when the PUSH button **A14** slides out together with an audible click.

- 1.3 Place the stainless steel bowl **A7** into the hole in the base unit **A8** and secure it in place by turning it clockwise. When the bowl is properly attached, it is not possible to lift it off the base unit.

2. Attaching an attachment (kneading hook, beater or whisk)

- 2.1 If you decide to use the transparent lid **A5**, then it is necessary to attach it prior to mounting any attachment. Carefully seat the lid on to the tilt-out arm and secure it in the locked position by turning it anticlockwise.
- 2.2 When attaching an attachment, the arm **A12** must be secured in the open position, see point 1.2 in chapter Inserting the mixing bowl. Attach one of the attachments to the T-shaped shaft of the mixing head **A9** so that the shaft fits into the hole on the attachment. Push the attachment towards the mixing head and turn it anticlockwise to secure it to the shaft.
- 2.3 With one hand, hold the attachment and gently pull it downwards. If it is properly secured to the shaft, it will not come off.
- 2.4 If you will not be immediately placing ingredients into the mixing bowl **A7**, press the PUSH button **A14** and tilt the arm **A12** to the horizontal position. When the arm is tilted to the horizontal position, the PUSH button **A14** will slide out accompanied by an audible click.

3. Removing the attachments and mixing bowl

- 3.1 Release the arm **A12** by pressing the PUSH button **A14** and tilt it upwards. The arm is locked in the open position when the PUSH button **A14** slides out together with an audible click.
- 3.2 Hold the attachment and gently push it towards the mixing head **A9**. Then rotate it clockwise until it is released from the motor shaft and take it off. Turn the mixing bowl **A7** anticlockwise and take it off the base unit **A8**. Move the arm **A12** back to the horizontal position.

OPERATION

1. Unwind the necessary length of power cord from the compartment **A17**.
2. Release the arm **A12**, by pressing the PUSH button **A14** and tilt it out.
3. Put the ingredients into the bowl **A7** and place the bowl into the base unit **A8**.

Attention:

The maximum weight of the ingredients that can be processed in a single batch is 1.6 kg. When preparing bread dough, do not process more than 600 g of flour at once. When preparing dough for sweet pastries (fruit cakes, etc.) it is not possible to process more than 450 g of flour in a single batch. The maximum number of egg whites that can be whisked at once is 8.



4. Press the PUSH button **A14** and tilt the arm **A12** together with the attached attachment to the horizontal position.
5. Make sure that the food processor is correctly assembled and that the speed control knob **A15** is set to position 0 (stand-by mode). Connect the power cord to an el. power socket.
6. Use the speed control knob **A15** to set the required speed level from 1 to 6. First, set a lower speed to prevent ingredients from being splattered around. As soon as they are mixed together, increase the speed to the required level. The speed can be adjusted at any time as required.

Attention:

If it is necessary to wipe ingredients off the inside of the mixing bowl **A7** and the attachment, first turn off the food processor by setting the speed control knob **A15** to position 0 (stand-by mode) and then disconnect it from the power socket. Then wipe away the ingredients using a plastic spatula.



The maximum operating time is 6 minutes. Do not leave the appliance in continuous operation for longer than indicated above. This is especially true under a heavy load (e.g. when processing heavy, thick doughs). If the appliance is in operation under heavy load, allow it to cool down for at least 10 minutes before turning it on again. At lower loads, a cooling time of 3 to 5 minutes is usually sufficient.

In the event that the appliance runs non-stop for 10 minutes, it will stop automatically.

7. After you have finished using the appliance, set the speed control knob **A15** to position 0 (stand-by mode) and disconnect the power cord from the power socket.
8. Disassemble the food processor according to the instructions included in chapter Assembling and disassembling the appliance. Use a soft plastic spatula to remove mixes from the mixing bowl **A7** and the attachment.
9. Clean out the food processor after each use according to the instructions in chapter Cleaning and maintenance.

QUICK GUIDE TO BEATING WHIPPING WITH KNEADING

Attachment type	Ingredients	Amount	Processing time	Speed selection
Elastic balloon whisk A2	Egg whites	max.8 pcs	4 minutes	Level 6
Elastic balloon whisk A2	Cream	500 ml	4-5 minutes	Level 6
Elastic balloon whisk A2	Mayonnaise	3 egg yolks	1 minute	Level 2-4
Beater A3	Cake dough	approx. 800 g	6 minutes	Level 2-6
Kneading hook A1	Bread dough	max.600 g of flour	4 minutes	Level 2

**Note:**

The above processing times are only a reference. To prevent ingredients from splattering out of the bowl, select an initial speed level of 1 or 2. Later set a higher speed based on requirements.

BLENDING**ASSEMBLING THE BLENDER**

1. If the blending jar **A20** is not seated on the blade assembly **A21**, put it on and turn it clockwise to lock it in position.
2. Seat the outer lid **A19** on to the blending jar and push it down along its entire perimeter so that it firmly adheres to the edges of the blending jar. Insert the cap **A18** into hole of the lid **A19** so that the tabs along the perimeter of the cap slide into the grooves in the lid **A19**. Secure the cap **A18** in position by turning it clockwise.
3. Make sure that the appliance is turned off and disconnected from the power socket. The arm **A12** must be tilted down to the horizontal position, the mixing head shaft **A9** must be without attachments **A1** to **A4** and the stainless steel bowl **A7** must be seated in the base unit **A8**. Take the lid **A10** off the arm **A12** and place the assembled blending jar on to the hub **A11**. Secure the blending jar on the hub by turning it clockwise. The appliance is equipped with a safety mechanism that will prevent the blender from starting unless it is correctly secured.

USING THE BLENDER

1. The blender is intended for preparing meals and drinks such as nutritional drinks, milkshakes, creamy soups, sauces, spreads, fresh baby foods, etc. It is not intended for juicing fruit and vegetables, preparing potato puree, yeast dough or for whipping egg whites.
2. Place the prepared ingredients into the blending jar **A20** and assemble the blender according to the instructions in chapter Assembling and disassembling the blender.

**Note:**

The maximum capacity of the blending jar **A20** is 1.5 litres, however, we do not recommend filling the blending jar with an amount of liquid greater than 1 litre. Certain liquids increase in volume while blending and, therefore, are best prepared in smaller batches.

3. Make sure that the appliance is correctly assembled and that the speed control knob **A15** is set to position 0 (stand-by mode). Connect the power cord to a power socket.
4. Set the required speed using the speed control knob. We recommend to first set the slower speed to allow the ingredients to mix together. Then you can increase the speed. Another alternative is to directly select a blending mode, which has the appropriate speed already set. While blending, always use your hand to hold down the lid from above.

**Attention:**

The maximum operating time of the blender is 1 minute. Do not leave the appliance in continuous operation for longer than indicated above. Then allow the appliance to cool down for 10 minutes.

5. While blending, you may add food or liquids to the blending jar **A20** through the hole in the lid **A19** after removing the inner cap **A18**. Never open the lid **A19** during operation. When processing hot liquids, the inner cap **A18** must remain closed.
6. In the event that food is sticking to the blade assembly **A21** or the walls of the blending jar **A20**, turn the appliance off by turning the speed control knob to position 0 (stand-by mode) and disconnect it from the power socket. Make sure that the blade assembly has stopped rotating. Remove the blending jar from the hub. Open the lid and, using a spatula, clean the blade assembly and the walls of the blending jar. Put the lid back on and reattach the blender assembly to the multi-function head. Plug the power cord into a power socket and continue blending.
7. After you have finished using the appliance, set the speed control knob to position 0 (stand-by mode) and disconnect the power cord from the power socket. Check that the blade assembly **A21** has stopped rotating and take the blending jar assembly off the multi-function head. Use a soft plastic spatula to remove food from the blending jar.
8. Clean out the individual parts after each use according to the instructions in chapter Cleaning and maintenance.

DISASSEMBLING THE BLENDER**Note:**

Before disassembling the blender, the blending jar must be empty and clean.

1. Remove the lid **A19** from the blending jar **A20**.
2. Turn the blending jar upside down
3. Use one hand to grasp the handle of the blending jar and with the other hand release the removable blade assembly **A21** by turning it anticlockwise, see fig. **C2**.
4. In the event that the blending jar cannot be released manually, fasten it into the hub **A11** of the blending hub **A9** and put the lid **A19** on to the blending jar, see fig. **C3**.
5. With one hand, gently push down on the lid **A19** from above and with the other hand turn the blending jar clockwise so that it is slightly released from the hub **A9**, see fig. **C4**.
6. Take the blending jar off the hub **A9**.
7. Remove the blade assembly **A21** by repeating steps 1 to 3.

USING THE SMOOTHIE BLENDER

1. The smoothie blender is intended for preparing fruit and vegetable smoothie drinks.
2. Add the liquids and food that you wish to blend into the nutri-bottle **A22**. Larger ingredients must be first cut into cubes measuring approximately 2 cm. When filling the nutri-bottle **A22**, follow all the safety instructions and the maximum amounts of ingredients as specified for the respective type of accessory in subchapter Quick guide to processing ingredients. The maximum capacity of the nutri-bottle **A22** is 0.6 litres. Never fill it past the maximum mark.
3. Put the blade assembly **A23** on to the neck of the nutri-bottle **A22** so that the chopping blades point into the nutri-bottle **A22** and screw it in tightly, see figure **B2**.

**Warning:**

When handling the blade assembly **A23**, in order to prevent injury, it is necessary to be especially careful. Do not touch the blade edge.

4. Make sure that the appliance is turned off and disconnected from the power socket. The arm **A12** must be tilted down to the horizontal position, the shaft of the hub **A9** must be without attachments **A1** to **A4** and the stainless steel bowl **A7** must be seated in the base unit **A8**. Remove the cover **A10** from the arm **A12**.
5. Turn the assembled nutri-bottle **A22** over so that the blade assembly **A23** is at the bottom. As shown in figure **B4**, place the assembled nutri-bottle on to the hub **A11** and turn it clockwise all the way. The appliance is now assembled and ready for use.
6. Set the speed control knob **A15** to the smoothie mode.
7. Adhere to the maximum amount of food, processing times and speed settings as specified in the table in the Quick guide to processing ingredients. The maximum continuous operating time is 1 minute.

**Attention:**

The shaft of hub **A9** will move when the smoothie blender is used.

8. After you have finished using the appliance, set the speed control knob **A15** to position 0 (off) and disconnect the power cord plug from the power socket. Before disconnecting it from the power socket, wait until the moving parts come to a stop.
9. To disassemble proceed in the reverse sequence. The smoothie blender must be taken off the appliance very carefully so as not to loosen the blade assembly **A23** from the neck of the nutri-bottle **A22**.
10. If you wish to use the bottle **A22** as a drink bottle, attach the lid **A24** to the neck of the nutri-bottle **A22**, see figure **B5**. Make sure that the drinking spout is properly closed so as not to spill the bottle's contents when carrying it.

ADVICE AND TIPS FOR BLENDING

- First cut food with a firm consistency such as fruit and vegetables into smaller pieces measuring 2 to 3 cm and only then blend it.
- First, blend a smaller amount of ingredients and then gradually add more ingredients through the hole in the lid **A19** while blending. In this way, you will achieve better results than by adding all ingredients into the blending jar **A20** at once.
- If you need to blend food of a solid consistency together with liquids, we recommend that you first blend the food of solid consistency with a smaller amount of the liquids. Then gradually add the remaining liquids through the hole in the lid **A19** while blending. While blending, always use your hand to hold down the lid from above.
- To blend very thick liquids, we recommend using the pulse level so that the blade assembly **A21** does not get jammed too often. Start the blender repeatedly in short intervals.
- Ice cubes must be processed immediately upon being removed from the freezer. When the ice starts to melt, the ice cubes will stick together and it will not be possible to blend them.

QUICK GUIDE TO PROCESSING INGREDIENTS

Ingredients	Speed selection	Recommended blending time
Fruit, vegetables cut into smaller pieces	or 5-6	30 s
Baby food	or 5-6	40 s
Spreads, dressings, marinades	or 5-6	30 s
Soups	or 5-6	30 s
Smoothies and cocktails	or 5-6	40 s
Ice cubes		As necessary

**Note:**

The above food processing times are only a reference. The actual blending time depends on the size of the ingredients, their amount and the required final consistency.

CLEANING AND MAINTENANCE

- Before cleaning the food processor, always turn it off by setting the speed control knob **A15** to position 0 and disconnect it from the power socket.
- After every use, it is necessary to thoroughly clean any used attachments in hot water and neutral kitchen detergent. Then rinse it under clean running water and thoroughly wipe dry with a fine wiping cloth.



Note:

The attachments are intended for short term contact with food (including beverages), i.e. max. 4 hours.

Plastic accessories may be washed in a dishwasher. Do not wash metal parts in a dishwasher, otherwise their surface may be damaged. Certain foods may cause discolouration of plastic parts on accessories. If this occurs, coat these parts with cooking oil and then wash in the normal way.

- Wash the stainless steel mixing bowl **A7** using hot water and neutral kitchen detergent. Then rinse it under clean running water and wipe dry with a fine wiping cloth.



Tip:

If you whisked egg whites, first rinse the elastic balloon whisk **A2** and the mixing bowl **A7** under cold water. If you were to use hot water, the egg white remains would harden and their removal would be more difficult.

- To clean the base unit **A8** and the arm **A12**, use a cloth dipped in a weak detergent solution. Then wipe everything dry.
- Never submerge the appliance or its power cord in water or any other liquids. For cleaning do not use thinners or solvents or cleaning agents causing abrasion. Otherwise, the surface of the appliance may be damaged.
- Disassemble the assembled blending jar **A20** and nutri-bottle **A22** into their individual parts and thoroughly wash them with warm water using neutral kitchen detergent. Then rinse the bottles or parts under clean running water and thoroughly wipe dry with a fine wiping cloth.



Attention:

When cleaning blade assemblies **A21** and **A23**, take special care to avoid injury on the sharp cutting edges.

STORAGE

- If you will not be using the food processor, store it in a dry place out of children's reach. Make sure that the arm **A12** is tilted into the horizontal position.

TIPS AND ADVICE

BREAD DOUGH – INGREDIENTS

FLOUR

This is the most important ingredient used for baking bread. Together with yeast it creates the texture of the loaf. When it is mixed with a liquid, the proteins contained in it start to create gluten. Gluten is a web of flexible fibres which entrap gases produced by the yeast.

White wheat flour

It is sold as baking flour, bread flour or fine wheat flour. Fine flour is the most readily available, nevertheless, you will achieve better result with flour with a protein content of at least 11% to 12%. The recipes included in this user's manual require the use of bread flour with a protein content of 11%. This information is provided on the packaging of the flour. Do not sieve the flour or use flour with baking powder unless specified in the recipe.

Whole grain wheat flour

It is produced from wheat grains and contains bran and germ. Bread baked from this type of flour will be denser. You will achieve a less dense bread by replacing one cup of whole grain flour with one cup of white bread flour.

Rye flour

It is very popular in bread making. It contains a large amount of mineral compounds, but has a low protein content and so it is usually combined with wheat flour to ensure that the bread rises well.

Gluten flour

It is produced by extracting gluten from wheat grains. Adding gluten flour can improve the texture and quality of the bread when using a flour with a lower protein content.

BREAD MIXES

They contain flour, sugar, dried milk, salt and other ingredients such as bread improver. Usually water and yeast is added.

BREAD IMPROVER

It is available in supermarkets and health food stores. The ingredients contained in bread improver are usually food processing industry acids such as ascorbic acid (vitamin C) and enzymes (amylase) extracted from wheat flour. Bread improver will help in firming up the dough, thus achieving a larger size loaf and finer texture. The bread is more stable and lasts longer.

SUGAR

It provides sweetness, flavour and a brown colour to the bread crust. It is added to yeast. White sugar, brown sugar or honey are suitable.

DRIED MILK AND DAIRY PRODUCTS

They enrich the taste and increase the nutritional value of the bread. Dried milk is suitable and easy to use. Store it in an air-tight container in the refrigerator. Likewise, dried soya milk may be used but it makes the bread tougher. Fresh milk should not be substituted unless indicated in the recipe otherwise.

SALT

It is an important ingredient for baking bread. It increases the absorption capacity of the dough, improves kneading, supports gluten development and has an effect on the shape of the loaf, texture of the crumb, taste and increases the lifetime of the bread. Measure it out carefully as it prevents the bread from rising.

FAT

Adds flavour and retains moisture. Vegetable oils such as safflower, sunflower or rapeseed oil may be used. Oils can be substituted for by butter or margarine, however the crust colour may become yellowish.

YEAST

It is used as a leavening agent. The recipes in this user's manual use dried yeast. Prior to using dried yeast, always check the use-by-date because yeast with an expired use-by-date may cause the dough not to rise.

Three times as much fresh or pressed yeast must be used compared to dried yeast. To create a starter, one needs liquid, sugar and heat.

FAST RISING YEAST

It is a mix of yeast and bread improver. If you wish to replace standard yeast in your recipe with this type of yeast then leave out the bread improver. Fast rising dough should not be used in combination with bread mixes as a bread improver is usually already contained in them.

WATER

Standard tap water is usually used. It is necessary to warm cold water up to room temperature before use. Water that is too cold or too hot will prevent the starter from forming.

EGGS

They are used in certain bread recipes. They help the dough to rise and increase the nutritional value of the bread. They add flavour and a fine crust and usually are used for sweeter types of bread.

OTHER INGREDIENTS

Ingredients such as dried fruit, nuts, chocolate chips, etc. which should remain whole in the baked bread, should be mixed into the dough. They should be added to the dough gradually during the kneading process before the dough rises.

BREAD DOUGH – PREPARATION

- Check the minimum lifetime or the use-by-date of all the ingredients.
- Add the ingredients in the order that they are provided in the recipe.
- Store opened foods in air-tight containers.
- Allow ingredients that you have taken out of the refrigerator to first reach room temperature before using them.
- If not indicated in the recipe otherwise, use bread flour. Do not use flour with a protein content lower than 11%.
- Do not use flour with baking powder for making a yeast-based bread, unless indicated otherwise in the recipe.
- If you live in a location that is above 900 m above sea level, you will probably need to adjust the amount of yeast indicated in the recipe. The higher the above-sea-level altitude, the lower the air pressure and the faster dough rises.
- It is recommended to use ¼ of a teaspoon of yeast less than indicated in the recipe.
- If the weather is hot and humid, use ¼ of a teaspoon of yeast less than is indicated in the recipe to prevent the dough from over-rising.
- The properties of the flour may change with the season or type of storage. Then it is necessary to adjust the water to flour ratio in the following way. If the dough is too sticky, add 1 to 2 tablespoons of flour. If the dough is too dry, add 1 to 2 tablespoons of water. Several minutes are needed for these ingredients to be absorbed. It should be possible to shape a dough with the right amount of flour and water into a smooth loaf that is moist to touch but not sticky.

How to prepare a yeast starter

- Pour the amount of warm water indicated in the recipe into a clean glass bowl. Then add the necessary amount of fresh or pressed yeast together with 1 teaspoon of sugar and one teaspoon of flour. Carefully mix everything together and cover with a plastic bag. Leave it in a warm place (30 °C) for approximately 30 minutes or until the mixture foams up. This mixture should be used immediately.

Rising in a warm location

- Yeast, whether it be during fermentation or in the dough, requires heat to grow in volume. Create a warm place for rising your dough by placing a metal baking tray onto a bowl with sufficiently hot water. Place the prepared dough on to the baking tray and cover with a lightly greased thicker plastic bag or a kitchen wiping cloth. A warm location without a draft is required for dough to rise. Allow the dough to rise until it doubles in volume.

CAKE AND PASTRY DOUGH – INGREDIENTS

FLOUR

Flour used for cakes and fine pastries should have a lower protein (gluten) content, than flour used for baking bread.

Medium-fine and fine flour

This flour has a lower protein (gluten) content and gives the baked goods, such as cakes, tarts, fine pastry, pancakes a finer texture.

Flour with baking powder

It is a mixture of flour and leavening agents such as baking powder. To make 1 cup of the flour and baking powder mixture, mix 1 cup of flour with 2 teaspoons of baking powder.

Whole grain flour

Contains bran and wheat germ and may be used in doughs for tarts and pies. The texture of a product made from whole wheat flour will be denser.

Corn flour

It is made from corn and is used for certain baked goods to which it loans a finer texture. It may be used to thicken sauces and desserts.

Rice flour

It is made from rice and is used to make the texture of baked goods finer, for example for shortcrust pastry.

BAKING POWDER

It is used as a leavening agent in baking.

BAKING SODA

It is known as sodium bicarbonate. It can be used as an additional leavening agent or for darkening certain baked goods.

BUTTER

It provides a specific taste and a fine texture to baked goods. In certain recipes it is possible to substitute oil for butter, however the resulting taste and texture of the baked good will be different. In this case, use $\frac{1}{4}$ less butter than the amount of oil indicated in the recipe. Before you start whipping butter together with sugar, allow it to soften at room temperature.

EGGS

Eggs should be at room temperature to give the correct volume to baked goods. Crack the eggs individually into a separate bowl and only then add to the other ingredients. This will prevent ruining the entire batch if one of the eggs is rotten. If you will be whisking the egg whites, carefully separate them from the yolks. Egg yolks contain fat and their remains prevent the successful whipping up of egg whites. Before you start whipping the egg whites, make sure that the whisk and the mixing bowl are completely clean and without fat residues. Otherwise, the egg whites might not be perfectly whipped.

MILK

Full-cream milk should be used unless indicated in the recipe otherwise. Low-fat or half-cream milk can be used but the final taste and texture of the baked goods may be different.

SUGAR

Usually white granulated sugar is used. It adds flavour, texture and colour to baked goods.

Caster sugar is also frequently used because it dissolves easier when it is whipped with butter. Brown sugar may be used to add a different taste and colour to the baked goods.

BAKING

- Allow the oven to preheat to the correct temperature before starting baking.
- The baking temperature may differ depending on the type of baking oven. Reduce the temperature indicated in the recipe by $15 - 20^\circ\text{C}$ if using a hot-air oven.
- Instead of floured baking pans and trays, you can use parchment paper if appropriate. You can coat the baking pan with a small amount of fat to prevent the parchment paper from sliding on the smooth surface of the baking pan.
- Test that the baked good is finished before taking it out of the oven. Gently touch the top of the baked good, if it returns to its initial shape, it should be properly baked. Carefully insert a skewer into the middle of the baked good and pull it out. If the dough does not stick to the skewer, the baked good is finished.
- To make biscuits crispier, take the baking tray out of the oven and place it onto a metal rack. Move the individual items on the baking tray from their baking location and allow them to cool down. Once they cool down move them from the baking tray to a platter.

RECIPES

Sponge cake

4 eggs, separated egg whites from yolks
 $\frac{1}{4}$ of a cup of caster sugar
1 cup (150 g) of medium-fine flour with baking powder, sieved
3 tablespoons of water

- Use the elastic balloon whisk **A2**.
- Set the speed level to 6 and whisk up the egg whites into a thick foam. Reduce the speed level to 1 and slowly add sugar until the foam thickens and stops to be smooth.
- Add the egg yolks and mix carefully.
- Set the speed level to 1 and intermittently add flour and water. Whisk until the ingredients combine.
- Pour the dough into a pre-prepared greased and floured baking pan.
- Bake in a preheated oven at 180°C for approx. 20–25 minutes.
- Allow the baked sponge cake to cool down on a metal rack.

Vanilla batter dough cake

125 g of butter, softened
 $\frac{3}{4}$ of a cup of caster sugar
1 teaspoon of vanilla essence
2 eggs
2 cups (300 g) of medium-fine flour with baking powder, sieved
 $\frac{3}{4}$ of a cup of milk

- Use the A-shaped beater **A3**.
- Set the speed to 6 and beat the butter together with sugar until the mixture is fluffy and smooth.
- Add the vanilla essence, eggs one after the other and beat them thoroughly.
- Reduce the speed to 2 and slowly intermittently add flour and milk and beat until a smooth dough forms.
- Pour the dough into a pre-greased and floured baking pan with a diameter of 22 cm.
- Bake in a preheated oven at 180°C for approximately 45–50 minutes or until the dough is golden in colour.
- Allow the baked cake to cool down on a metal platter.

Butter biscuits (approx. 40 pcs)

125 g of butter, softened
 $\frac{3}{4}$ of a cup of caster sugar
1 teaspoon of vanilla essence
1 egg
2 cups (300 g) of medium-fine flour
1 teaspoon of baking powder

- Use the A-shaped beater **A3**.
- Set the speed to 6 and beat the butter until smooth. Add sugar, vanilla essence and the egg. Beat until a light smooth mixture is created.
- Mix the flour and the baking powder.
- Set the speed to 2 and gradually add the flour until everything is properly combined into a single mass. Do not, however, beat for too long.
- Use a teaspoon to form small balls and lay them out evenly on to a lightly greased or parchment paper covered baking tray. Leave sufficient room around each ball. Using a lightly floured fork, push down each of the balls.
- Bake in a preheated oven at 190°C for approximately 12–15 minutes or until the biscuits are lightly golden in colour.
- Take the biscuits off the baking tray and leave to cool down on a metal rack.

Cream snow puffs (20–24 pcs)

4 egg whites
1 cup of caster sugar

- Use the elastic balloon whisk **A2**.
- Set the speed level to 6 and whip up a thick snow from the egg whites. Lower the speed to level 1 and carefully add half the sugar and whip it in. Then add the remaining sugar.
- Using a spoon, apply a small amount of the snowy mixture on to a lightly greased baking tray. Leave about 3 cm around the individual pieces so that they do not bake to one another.
- Bake in the oven at 120°C about 1 to $1\frac{1}{2}$ hours or until the snow puffs are dry. To avoid burning them, do not, however, bake then too long. Take them off the baking tray and put them aside to cool down and store them in an air-tight container.



Note:

You can use a decorating tool to create larger snow puffs. This may necessitate a longer baking time.

White bread

- 4 cups (600 g) of bread flour
- 3 tablespoons of dried milk
- 1½ teaspoons of salt
- 1½ tablespoons of sugar
- 1 teaspoon of bread improver
- 2 teaspoons of instant yeast
- 2 tablespoons of oil
- 1½ cups (375 ml) of water
- additional bread flour for hand kneading

- Use the kneading hook **A1**.
- In the mixing bowl, mix the flour, dried milk, salt, sugar, bread improver and the instant yeast.
- Set the speed to 1–2 and slowly add water and oil into the dry mix. Leave it to knead until a dough starts to form.
- Move the dough on to a lightly floured rolling board and thoroughly knead by hand until the dough is sufficiently fine and smooth.



Note:

At this stage, the dough should be very well kneaded so that gluten is formed, which gives the dough the correct elasticity and helps it to rise.

- Place the dough into a large bowl and cover with plastic wrap. Allow it to rise in a warm place for about 20 minutes or until the dough doubles in size.
- Take the risen dough out of the bowl and knead once more on a lightly floured rolling board.
- Place the dough into a baking pan. Cover with plastic wrap and allow it rise in a warm place for about 30–40 minutes or until the dough has risen sufficiently. Remove the plastic wrap.
- You can apply an egg glaze before baking. Bake in a preheated oven at 200 °C for approximately 40–50 minutes or until the bread is golden in colour.
- Allow the baked bread to cool down for 15 to 20 minutes and then remove it from the baking pan. Allow the loaf to cool down completely before cutting it, to prevent it from collapsing.

Egg glaze for bread dough

- 1 egg, lightly beaten
- 2–3 tablespoons of water

- Mix both ingredients together until a smooth mixture is formed. Do not whip. If necessary strain through a sieve. Brush the egg glaze on to the bread dough before baking.

Focaccia (2–4 portions)

- 3 cups (450 g) of bread flour
- 1 teaspoon of salt
- 2 teaspoons of sugar
- 2 teaspoons of instant yeast
- 2 tablespoons of olive oil
- 1 cup (250 ml) of water

For glazing:

- 2 tablespoons of olive oil
- 1 tablespoon of coarse salt
- 2 tablespoons of black olives, sliced

- Use the kneading hook **A1**.
- In the mixing bowl, mix the flour, salt, sugar and yeast.
- Set the speed to 1–2 and slowly add water and oil into the dry mix. Leave it to knead until a dough starts to form.
- Move the dough on to a lightly floured rolling board and thoroughly knead by hand until a fine smooth dough forms.
- Place the dough into a large bowl and cover with plastic wrap. Allow it to rise in a warm place for about 20 minutes or until the dough doubles in size.
- Take the risen dough out of the bowl and knead once more on a lightly floured rolling board.
- Place the dough into a lightly greased Teflon baking pan of dimensions 20 × 30 cm and roll into the shape of the baking pan.
- Lightly cover with plastic wrap and allow it rise in a warm place for about 20–30 minutes or until the dough has risen a little. Remove the plastic wrap.
- Brush the dough with olive oil and sprinkle on the coarse salt and sliced olives.
- Bake in a preheated oven at 200 °C for approximately 30–35 minutes or until the focaccia bread is golden in colour.
- After taking it out of the oven, allow it to cool down on a metal rack.

TECHNICAL SPECIFICATIONS

Rated voltage range.....	220–240 V
Rated frequency.....	50/60 Hz
Rated power input.....	1000 W
Electrical shock protection class.....	II
Noise level	92 dB(A)

The declared noise emission level of the appliance is 92 dB(A), which represents a level A of acoustic power with respect to a reference acoustic power of 1 pW.

EXPLANATION OF TECHNICAL TERMINOLOGY



Safety class for electrical shock protection:

Class II – Electrical shock protection is provided by double or heavy-duty insulation.

Changes to text and technical parameters are reserved.

INSTRUCTIONS AND INFORMATION REGARDING THE DISPOSAL OF USED PACKAGING MATERIALS

Dispose of used packaging material at a site designated for waste in your municipality.

DISPOSAL OF USED ELECTRICAL AND ELECTRONIC EQUIPMENT



This symbol on products or original documents means that used electric or electronic products must not be added to ordinary municipal waste. For proper disposal, renewal and recycling hand over these appliances to determined collection points. Alternatively, in some European Union states or other European countries you may return your appliances to the local retailer when buying an equivalent new appliance. Correct disposal of this product helps save valuable natural resources and prevents potential negative effects on the environment and human health, which could result from improper waste disposal. Ask your local authorities or collection facility for more details. In accordance with national regulations penalties may be imposed for the incorrect disposal of this type of waste.

FOR BUSINESS ENTITIES IN EUROPEAN UNION STATES

If you want to dispose of electric or electronic appliances, ask your retailer or supplier for the necessary information.

Disposal in other countries outside the European Union.

This symbol is valid in the European Union. If you wish to dispose of this product, request the necessary information about the correct disposal method from the local council or from your retailer.



This product meets all the basic requirements of EU directives related to it.

Ovaj dokument je originalno proizveden i objavljen od strane proizvođača, brenda Sencor, i preuzet je sa njihove zvanične stranice. S obzirom na ovu činjenicu, Tehnoteka ističe da ne preuzima odgovornost za tačnost, celovitost ili pouzdanost informacija, podataka, mišljenja, saveta ili izjava sadržanih u ovom dokumentu.

Napominjemo da Tehnoteka nema ovlašćenje da izvrši bilo kakve izmene ili dopune na ovom dokumentu, stoga nismo odgovorni za eventualne greške, propuste ili netačnosti koje se mogu naći unutar njega. Tehnoteka ne odgovara za štetu nanесenu korisnicima pri upotrebi netačnih podataka. Ukoliko imate dodatna pitanja o proizvodu, ljubazno vas molimo da kontaktirate direktno proizvođača kako biste dobili sve detaljne informacije.

Za najnovije informacije o ceni, dostupnim akcijama i tehničkim karakteristikama proizvoda koji se pominje u ovom dokumentu, molimo posetite našu stranicu klikom na sledeći link:

<https://tehnoteka.rs/p/sencor-mikser-sa-posudom-stm-3751gr-eue3-akcija-cena/>