

Uputstvo za upotrebu (EN)

ENERGY SISTEM bežični zvučnik 5 G2 BT beli

ENERGY  SISTEM

Tehnoteka je online destinacija za upoređivanje cena i karakteristika bele tehnike, potrošačke elektronike i IT uređaja kod trgovinskih lanaca i internet prodavnica u Srbiji. Naša stranica vam omogućava da istražite najnovije informacije, detaljne karakteristike i konkurentne cene proizvoda.

Posetite nas i uživajte u ekskluzivnom iskustvu pametne kupovine klikom na link:

<https://tehnoteka.rs/p/energy-sistem-bezicni-zvucnik-5-g2-bt-beli-akcija-cena/>

ENGLISH

Introduction	3
Care and maintenance	3
Technical specifications	4
Audio	4
Bluetooth	4
TWS technology compatible with	4
USB and microSD player	4
Analogue inputs	4
FM radio	4
Power supply	4
Other features	4
Product content	4
General overview	5
Main Functions	6
Switching on and off the device	6
Playback modes	6
Bluetooth --> SD --> USB --> AUX --> Radio	6
Playback control	6
Bluetooth (BT)	7
True Wireless Stereo (TWS)	7
Removable storage units (USB sticks/MicroSD cards)	7
FM radio	8
Auxiliary audio input	9
USB port to charge external devices	9
Equaliser	9
Firmware update	9
Warranty	10
Warranty	10
Warranty	10
Declaration of conformity	10



Introduction

Thank you for trusting our company and buying the new *Tower 5 g2*. We hope you enjoy it. Before you start using the device, we strongly recommend reading this manual to get used to it.

Care and maintenance

- Do not expose your *Tower 5 g2* to impacts, dust, humidity or high temperatures.
- Use neither corrosive nor abrasive cleaning products.
- Do not press the speaker membranes since they could be damaged.
- Do not disassemble the device. All repair works should be carried out exclusively by qualified staff of Energy System Technology, S.A.

Technical specifications

Audio

- Sound system: stereo (2.1).
- Power: 65 W
- Frequency response: 40 Hz - 18 kHz.
- 1 subwoofer: 5", 30 W.
- 2 full range speakers: 4", 15 W.
- 1 tweeter: 1", 5 W.
- Bass reflex.
- Signal/Noise ratio: > 90 dB.

Bluetooth

- Bluetooth 5.0. True Wireless Stereo. Class II.
- Up to 20 m range.
- Compatible Bluetooth profiles: A2DP, AVRCP.
- Frequency band: 2.4 GHz.
- Maximum output power: < 20.00 dBm.

TWS technology compatible with

- Tower 5 g2

USB and microSD player

- Player for microSD cards and USB sticks (up to 128 GB).
- Supported formats: WAV and MP3.
- Change folder feature.
- Shuffle and repeat modes.

Analogue inputs

- 3.5 mm jack input (analogue input).

FM radio

- Detachable antenna with IEC connector.
- Frequency range: 87.5 ~ 108 MHz
- Automatic tuning with 50 presets
- Manual tuning and memory presets.

Power supply

- AC/DC power adapter: 100 ~ 240 V/ 50 ~ 60 Hz
- Plug for electric socket: EU plug
- Power cable length: 150 cm
- Power consumption at medium volume: 6 Wh
- Power consumption at maximum volume: 30 Wh

Other features

- 2-band analogue equaliser.
- Digital equaliser with 5 EQ modes.
- Wood cabinet.
- Remote control with up to 10 metres range.
- USB charging port: 5 V, 2 A.
- LED segment display.

Product content

- Tower 5 g2
- Remote control + AAA batteries

- Quick guide
- FM antenna

General overview

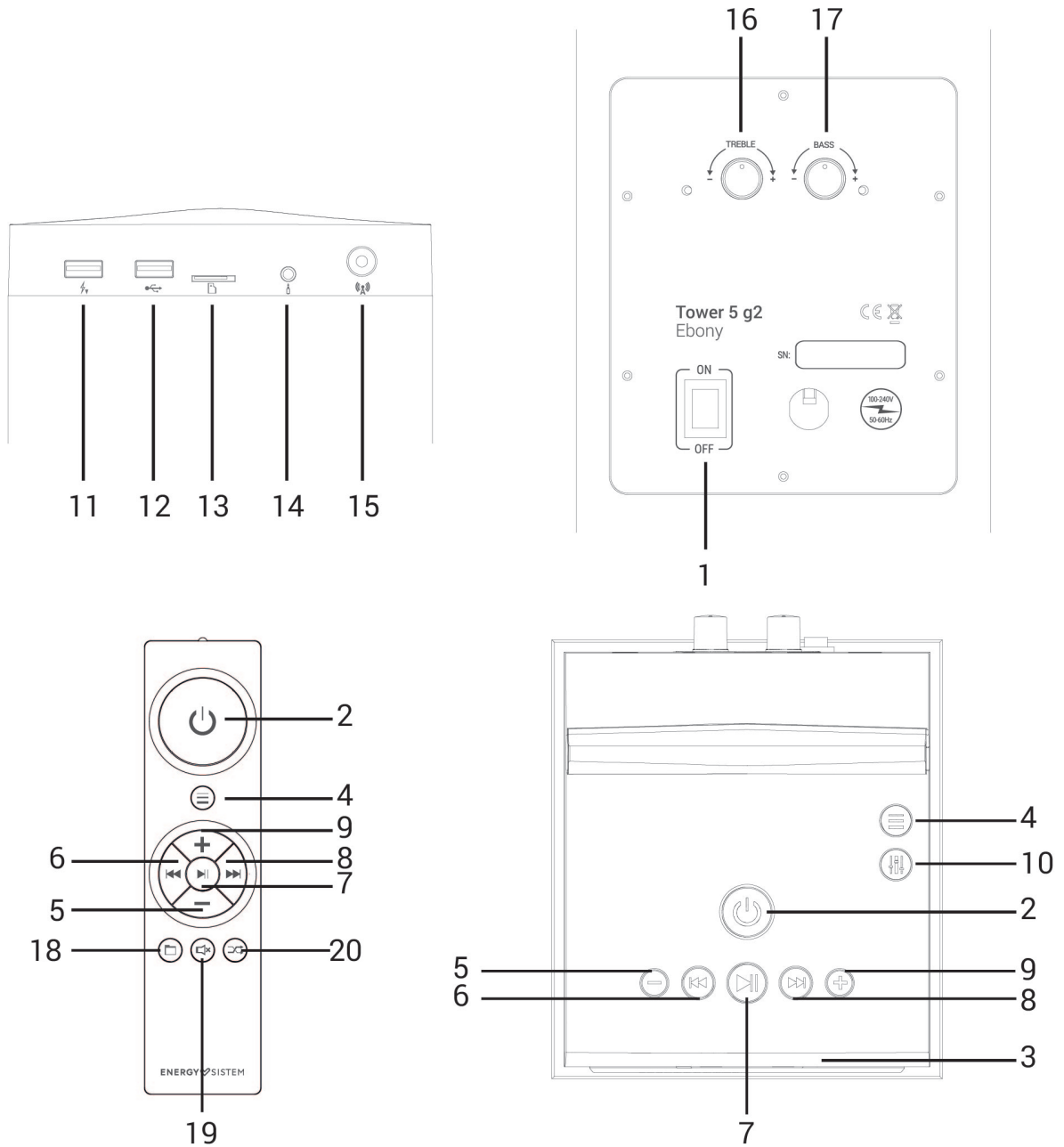

1. Power switch
2. On/Off
3. LED display
4. Playback mode
5. Volume -
6. Back
7. Play/Pause
8. Next
9. Volume +
10. Equaliser
11. USB charging port
12. USB playback port

13. MicroSD card slot
14. 3.5 mm audio-in (AUX)
15. FM radio antenna connector
16. Treble equaliser
17. Bass equaliser
18. Change folder
19. Mute
20. Repeat mode

Main Functions

Switching on and off the device

Plug the power cable on the back of your *Tower 5 g2* into the socket and move the *Power switch (1)* to the "ON" position.

To switch on your *Tower 5 g2*, press *On/Off (2)* on the top panel or the provided remote control. At this point, the *LED display (3)* lights up showing the selected playback mode.

Press and hold *On/Off (2)* on the top panel or remote control for 2 seconds to switch off the device. The *LED display (3)* will switch off.

Note 1: When switching on the device, it will always enable the last selected playback mode.

Note 2: If you are not going to use your *Tower 5 g2* for a long period of time, we recommend moving the *Power switch (1)* to the "OFF" position.

Playback modes

Once the *Tower 5 g2* is on, you can choose the playback mode you prefer. To do so, press *Playback mode (4)* repeatedly until finding the preferred playback mode. Playback modes will appear in the following order:

Bluetooth --> SD --> USB --> AUX --> Radio

If you plug a removable storage unit (USB stick or SD card) or use the AUX input, your *Tower 5 g2* will enable the corresponding playback mode and will play the content automatically.

Playback control

Once selected the preferred playback mode, you can control music playback directly from the *Tower 5 g2* or using the remote control.

Press *Play/Pause (7)* to play or pause a song.

Press *Volume - (5)* or *Volume + (9)* to adjust the volume level according to your preferences.

Press *Back (6)* or *Next (8)* to skip to the previous or next song.

If you plug a USB stick or an SD card, press and hold *Play/Pause (7)* for 2 seconds or press repeatedly *Repeat mode (20)* on the remote control to select the preferred playback mode. The information below will appear on the *LED display (3)*:

1) **ALL:** all USB or card contents will be repeated. The folders and files stored on your removable storage units will be read in chronological order.

2) **ONE:** the song you are listening to will be repeated.

3) **RANDOM:** random playback of all the contents of your removable storage unit.

4) **FOLDER:** the folder with the songs you are listening to will be repeated.

Press *Mute (19)* on the remote control to mute playback.

If you prefer to switch to another folder, press *Change folder (18)* on the remote control.

Important: If you are using the AUX input, you will have to control playback from the connected music player.

Bluetooth (BT)

To pair your sound tower with a Bluetooth device, press *Playback mode (4)* until Bluetooth mode is enabled. The Bluetooth symbol (bt) will appear on the *LED display (3)*.

At this point, access the Bluetooth settings on the device and search for *Energy Tower Tower 5 g2* among the detected devices. Select it to establish the connection. You will hear a sound confirming both devices are correctly paired. At this point, the Bluetooth symbol (bt) is displayed permanently on screen.

Your *Tower 5 g2* pairs with the source device automatically when turning on the sound tower once again, provided that Bluetooth is enabled on the source device.

Press and hold *Playback mode (4)* for 2 seconds to disconnect the current device and pair the sound tower with a new device. You will hear a sound when both devices disconnect and the Bluetooth symbol (bt) will flash on the *LED display (3)*.

True Wireless Stereo (TWS)

This technology allows you to wirelessly connect another True Wireless Stereo device within a maximum distance range of 20 metres to increase power and create a stereo system with separate left and right channels.

To do so, switch on both devices and enable Bluetooth mode.

Press and hold *Play/Pause (7)* for 2 seconds on the sound tower on the left side of the room. This tower will be assigned the left channel. Two letters, "L" and "R", will flash on the *LED display (3)*. This means the first tower is searching for new devices. Repeat the steps above on the second tower: press and hold *Play/Pause (7)* for 2 seconds. Wait a few seconds until both towers connect to each other. You will hear a confirmation sound. At this point, the letters "L" and "R" light up permanently.

To disable the True Wireless Stereo function, press and hold *Play/Pause (7)* for two seconds on any sound tower. You will hear a confirmation sound when both units disconnect.

Removable storage units (USB sticks/MicroSD cards)

Play .mp3 and .wav files from your USB sticks or microSD cards (up to 128 GB). Plug the USB stick into the *USB playback port (12)* or the microSD card into the *MicroSD card slot (13)*. The sound tower plays the contents automatically a few seconds after inserting the storage unit.

If you turn off your *Tower 5 g2* or select another playback mode, the internal memory will save the moment where you paused playback. This way, music playback will always resume from the last track you listened to.

Press *Play/Pause (7)* to play or pause a song.

Press *Volume - (5)* or *Volume + (9)* to adjust the volume level according to your preferences.

Press *Back (6)* or *Next (8)* to skip to the previous or next song.

To select the next folder, press and hold *Playback mode (4)*.

If you plug a USB stick or a microSD card, press and hold *Play/Pause* (7) for 2 seconds or press repeatedly *Repeat mode* (20) on the remote control to select the preferred playback mode. The information below will appear on the *LED display* (3):

- 1) **ALL:** all USB or card contents will be repeated. The folders and files stored on your removable storage units will be read in chronological order.
- 2) **ONE:** the song you are listening to will be repeated.
- 3) **RANDOM:** random playback of all the contents of your removable storage unit.
- 4) **FOLDER:** the folder with the songs you are listening to will be repeated.

Press *Mute* (19) on the remote control to mute playback.

If you prefer to switch to another folder, press *Change folder* (18) on the remote control.

The root folders and files of your removable USB sticks and microSD cards will be read in chronological order and the songs included in your folders in alphabetical order.

Here you have a diagram of the reading order:

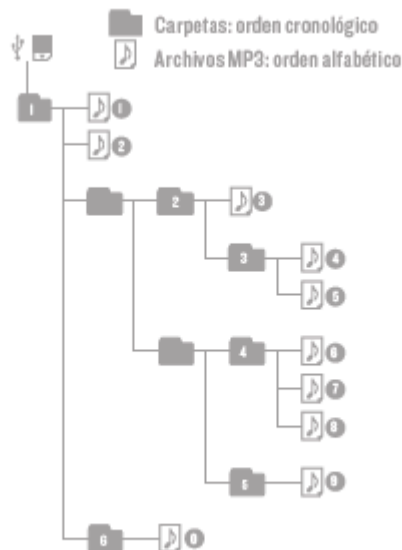

FM radio

To enable FM radio mode, press repeatedly *Playback mode* (4) until the radio symbol (rd) appears on the *LED display* (3).

Make sure the FM antenna cable is plugged into the *FM radio antenna connector* (15).

Automatic tuning

To carry out an automatic search of all radio stations, press and hold *Playback mode* (4) for 2 seconds. At this point, your *Tower 5 g2* starts searching for radio stations and shows the saved frequencies on screen.

Once the automatic search is complete, press and hold *Back* (6) or *Next* (8) to switch between the saved frequencies. Choose the one you want to hear.

Manual tuning

Press and hold *Play/Pause* (7) for 2 seconds if you prefer to carry out a manual search and fine-tune any frequency. When the *LED display* (3) starts flashing, you can fine-tune the selected frequency pressing *Back* (6) (tune -) or *Next* (8) (tune +).

Press and hold once again *Play/Pause (7)* for 2 seconds to confirm. The radio station will be saved and the *LED display (3)* will stop flashing.

Presetting radio stations

To preset radio stations, first select the frequency you want to move. Press and hold *Back (8)* for 2 seconds. At this point, the *LED display (3)* starts flashing and the preset numbers assigned to the radio stations appear on screen. Press *Back (6)* or *Next (8)* until you find the preset number you prefer. Once you have selected the new preset number you want to assign to the previously selected radio station, press and hold *Next (8)* for 2 seconds. The selected radio station will be saved under the new preset number immediately.

Erasing radio stations

If you want to erase a radio station, first select its corresponding frequency. Press and hold *Back (6)* for 2 seconds. At this point, the *LED display (3)* starts flashing. Press and hold the very same button for 2 seconds to erase the radio station.

Important: We recommend carrying out a new automatic search if you place the *Tower 5 g2* somewhere else.

Auxiliary audio input

Your *Tower 5 g2* features a *3.5 mm audio-in (AUX) (14)* to plug your music player using a 3.5 mm jack cable.

When using the audio-in (AUX), your *Tower 5 g2* enters AUX mode automatically, thus showing it is ready to start playing content from an external device.

Important: If you are using the AUX input, you will have to control playback from the connected music player.

USB port to charge external devices

Your *Tower 5 g2* features a *USB charging port (11)* to connect a USB cable and charge other devices such as smartphones, tablets or MP3 players, even if the sound tower is playing music.

Output technical specifications:

- Voltage = 5 V
- Current = 2 A

Equaliser

The device features a *Treble (16) and bass equaliser (17)* on the back to adjust the sound to your liking.

Lower treble as you turn up the tower volume to get a balanced sound. We recommend setting treble below 50% when the volume is above 20 points.

The device also features digital EQ modes. Press repeatedly *Equaliser (10)* to select the preferred EQ mode while the device is playing music. There are 5 EQ modes available:

EQ1: Flat or flat EQ.

EQ2: Bass, EQ for an extra bass boost.

EQ3: Treble, EQ for an extra treble boost.

EQ4: Mid high, EQ for a mid boost.

EQ5: Mid low, EQ for a mid cut.

Firmware update

Download the last version of the firmware [here](#)

Warranty

Warranty

Energy Sistem Technology, S.A. is liable for any lack of conformity for 36 months from the date the goods are purchased. Batteries are excluded from the 36-month warranty, having a warranty period of 24 months.

This warranty covers defects in workmanship or materials and does not cover product failures due to accidents, misuse or alteration made by an unauthorized person.

The extended 36-month warranty is valid for the European Union. For other countries please refer to your specific legislation or your local distributor.

Warranty

You can check the warranty terms [here](#)

Declaration of conformity

Issuer's name: Energy Sistem Technology, S.A. - CIF: A53107488

Address: C/ Calpe, 1 - 03509 Finestrat, Alicante (Spain)

Tel: +34 966 830 324

We declare under our sole and exclusive responsibility that the product:

Description: home speaker

Brand: Energy Sistem

Model: Tower 5 g2

Manufacturer: Energy Sistem Technology, S.A.

Manufacturing country: China

referred to in this declaration complies with the essential norms and standards:

EN 62479:2010

EN 62368-1:2014+A11:2017

EN 301 489-17 V3.2.2

EN 301 489-1 V2.2.3

EN 300 328 V2.2.2

in conformity with the provisions of the Directive 2014/53/EU of the European Parliament and of the Council of 16th April 2014.

Finestrat, 1st August 2020



Miguel Ángel Aragüez García

Innovation and Technology Director



Ovaj dokument je originalno proizveden i objavljen od strane proizvođača, brenda Energy Sistem, i preuzet je sa njihove zvanične stranice. S obzirom na ovu činjenicu, Tehnoteka ističe da ne preuzima odgovornost za tačnost, celovitost ili pouzdanost informacija, podataka, mišljenja, saveta ili izjava sadržanih u ovom dokumentu.

Napominjemo da Tehnoteka nema ovlašćenje da izvrši bilo kakve izmene ili dopune na ovom dokumentu, stoga nismo odgovorni za eventualne greške, propuste ili netačnosti koje se mogu naći unutar njega. Tehnoteka ne odgovara za štetu nanесenu korisnicima pri upotrebi netačnih podataka. Ukoliko imate dodatna pitanja o proizvodu, ljubazno vas molimo da kontaktirate direktno proizvođača kako biste dobili sve detaljne informacije.

Za najnovije informacije o ceni, dostupnim akcijama i tehničkim karakteristikama proizvoda koji se pominje u ovom dokumentu, molimo posetite našu stranicu klikom na sledeći link:

<https://tehnoteka.rs/p/energy-sistem-bezicni-zvucnik-5-g2-bt-beli-akcija-cena/>