

Uputstvo za upotrebu (EN)

TCL kombinovani frižider RB275GM1110

TCL



Tehnoteka je online destinacija za upoređivanje cena i karakteristika bele tehnike, potrošačke elektronike i IT uređaja kod trgovinskih lanaca i internet prodavnica u Srbiji. Naša stranica vam omogućava da istražite najnovije informacije, detaljne karakteristike i konkurentne cene proizvoda.

Posetite nas i uživajte u ekskluzivnom iskustvu pametne kupovine klikom na link:

<https://tehnoteka.rs/p/tcl-kombinovani-frizider-rb275gm1110-akcija-cena/>

- Please carefully read the operation Instructions before power on, and keep it properly.
- The products may subject to changes without notice.



The Creative Life

Two-Door Household Refrigerator Operating Instructions

RB275GM1110

Thank you for buying TCL refrigerator. We hereby express our thanks. Welcome to use TCL refrigerator. We will do our best to provide you with quality service.

Safety instructions	P2
Product introduction	P5
Handling and placement	P6
Preparations prior to use	P7
Operation notes	P8
Illustration and operation of display panel	P8
Food storage	P10
Ice-making	P10
Disassembly and assembly method of accessory	P13
Maintenance	P13
Failure analysis	P14
Non-failure	P14
Technical parameter	P15
Packing list	P15

1. **T**his appliance is not intended for use by persons (including children) with reduced physical, sensory or mental capabilities, or lack of experience and knowledge, unless they have been given supervision or instruction concerning use of the appliance by a person responsible for their safety. Children should be supervised to ensure that they do not play with the appliance.

2. **I**f the supply cord is damaged, it must be replaced by the manufacturer, its service agent or similarly qualified persons in order to avoid a hazard.

3. **T**his appliance can be used by children aged from 8 years and above and persons with reduced physical, sensory or mental capabilities or lack of experience and knowledge if they have been given supervision or instruction concerning use of the appliance in a safe way and understand the hazards involved. Children shall not play with the appliance. Cleaning and user maintenance shall not be made by children without supervision.

4. **WARNING:** Keep ventilation openings, in the appliance enclosure or in the built-in structure, clear of obstruction.

5. **WARNING:** Do not use mechanical devices or other means to accelerate the defrosting process, other than those recommended by the manufacturer.

6. **WARNING:** Do not damage the refrigerant circuit.

7. **WARNING:** Do not use electrical appliances inside the food storage compartments of the appliance, unless they are of the type recommended by the manufacturer.

8. **D**o not store explosive substances such as aerosol cans with a flammable propellant in this appliance.

9. **T**his appliance is intended to be used in household and similar applications such as

- **S**taff kitchen areas in shops, offices and other working environments;
- **F**arm houses and by clients in hotels, motels and other residential type environments;
- **B**ed and breakfast type environments;
- **C**atering and similar non-retail applications.

1. Warning

Warning: No barrier is allowed around the appliance or in the embedded structure in order to ensure the free ventilation.

Warning: It is forbidden to speed up the defrosting process with any mechanical equipment or by other method except for the method recommended by the manufacturer.

Warning: Never damage the refrigerating circuit.

Warning: Never use any electric apparatus in the food chamber of the appliance except for the type recommended by the manufacturer.

Warning: Never place the liquid beverage or food contained with glass container in the freezing chamber for fear of cracking.

Warning: If powered off, the refrigerator shall be powered on 5min later for fear of damaging the compressor.

Warning: If any live part, abnormal noise, smell, smoke or other abnormality is found during use, it is necessary to power off the appliance immediately and contact the aftersales service department of the Company timely.

Warning: Never place your finger or hand under the refrigerator, especially rear bottom of refrigerator; otherwise, you may be hurt by the sharp matter.

Warning: The children must not play or climb the refrigerator. The operation by the children must be supervised by their parents for fear of danger.

Warning: Never place your hand between the doors to open or close door for fear of jamming your finger. The door handle shall be used to open or close the door.

Warning: Under the climate types N, ST and T, the operating ambient range of the appliance is 16°C~43°C. If the appliance operates outside the rated climate type (ambient temperature range), the appliance may not maintain the satisfying interior temperature.



Warning: Risk of fire / flammable materials

Warning: When positioning the appliance, ensure the supply cord is not trapped or damaged.

Warning: Do not locate multiple portable socket-outlets or portable power supplies at the rear of the appliance.

Children aged from 3 to 8 years are allowed to load and unload refrigerating appliances

Opening the door for long periods can cause a significant increase of the temperature in the compartments of the appliance.

Clean regularly surfaces that can come in contact with food and accessible drainage systems.

Clean water tanks if they have not been used for 48 h; flush the water system connected to a water supply if water has not been drawn for 5 days.

Store raw meat and fish in suitable containers in the refrigerator, so that it is not in contact with or drip onto other food.

Two-star frozen-food compartments are suitable for storing pre-frozen food, storing or making ice-cream and making ice cubes.

One-, two- and three-star compartments are not suitable for the freezing of fresh food. If the refrigerating appliance is left empty for long periods, switch off, defrost, clean, dry, and leave the door open to prevent mould developing within the appliance.

2. Cautions

Cautions: The power supply of this product must be uniform with the power supply mentioned on the nameplate, and the standard independent 3-hole socket shall be used (above 10A, and reliably grounded). One socket must not be shared by more than one appliance; otherwise, fire may be caused due to overheat.

Cautions: Never pull the power wire by hand. It is necessary to hold and unplug the power connector from the socket to disconnect the power supply. The power wire or connector must not be touched by the wet hand for fear of electric shock.

Cautions: The power wire must not be squeezed by the refrigerator or any heavy load, and the power wire shall not be bent extremely. The damage or peeling of power wire may result in fire or electric shock. If the power wire is broken or cut, please contact the after-sales service department immediately.

Cautions: No flammable or explosive matter or corrosive acid or alkaline matter is allowed in the refrigerator.

Cautions: The refrigerator must not be used in the rain or under the sunshine.

Cautions: It is forbidden to place the container with fluid on the refrigerator because the breakage or turnover of the container may affect the electrical insulation of refrigerator and result in electric shock or fire.

Cautions: The refrigerator must not be disassembled or modified without permission. The repair of refrigerator must be performed by the specialist.

Cautions: In case of leakage of any flammable gas such as coal gas, it is necessary to close the leaking valve first and then open the window for ventilation, and forbidden to unplug the refrigerator connector immediately for fear of fire or explosion due to electric spark.

Cautions: Refrigerating appliances - in particular a refrigerator-freezer Type I - might not operate consistently (possibility of defrosting of contents or temperature becoming too warm in the frozen food compartment) when sited for an extended period of time below the cold end of the range of temperatures for which the refrigerating appliance is designed;

Cautions: The fact that effervescent drinks should not be stored in food freezer compartments or cabinets or in low-temperature compartments or cabinets, and that some products such as water ices should not be consumed too cold.

Cautions: The need to not exceed the storage time(s) recommended by the food manufacturers for any kind of food.

Cautions: The precautions necessary to prevent an undue rise in the temperature of the frozen food while defrosting the refrigerating appliance, such as wrapping the frozen food in several layers of newspaper.

Cautions: The fact that a rise in temperature of the frozen food during manual defrosting, maintenance or cleaning could shorten the storage life.

Cautions: The care required with regard to frozen food in storage in the event of an extended non-running of the refrigerating appliance (interruption of power supply or failure of the refrigerating system).

Cautions: The action to be taken when the refrigerating appliance is switched off and taken out of service temporarily or for an extended period (e.g. emptied, cleaned and dried, and the door(s) or lid(s) propped ajar).

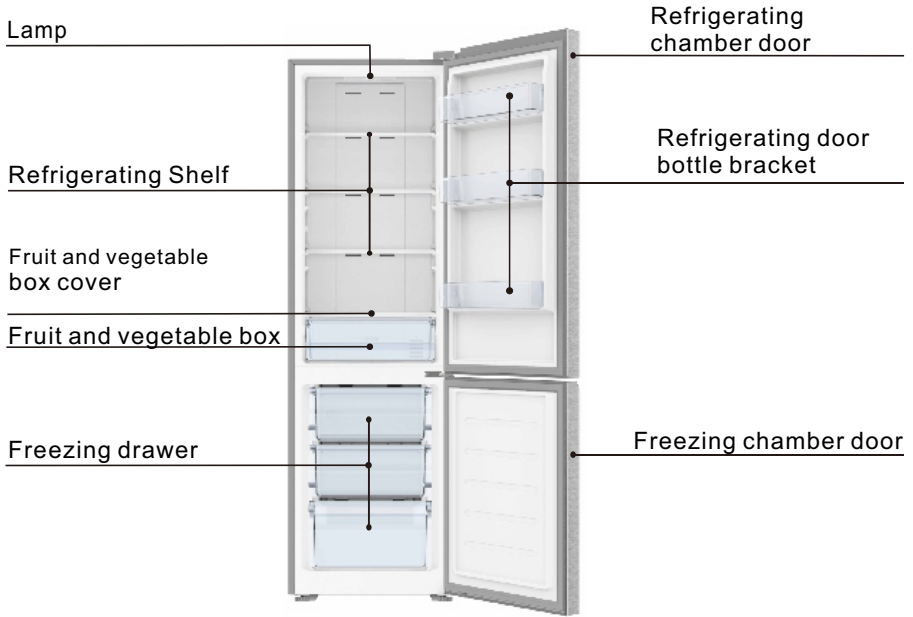

The pictures are for reference only. Please refer to the object

Features

- Computer intelligent temperature control; air cooling and frost free.
- Environmental-friendly refrigerant. It applies materials without CFC, R600a environmental-friendly materials. 80% of the main materials can be recycled;
- Transparent drawers with novel appearances and their internal foods can be clear at a glance;
- The tempered glass refrigeration shelves are height adjustable, wear proof, heat-proof and practical;
- The concealed condenser applies flat back design. It has perfect and coordinated style which is simple, easy to clean and high utility rate of space;
- This product adopts the efficient mute compressor of international brand and special case foaming technology, and features low noise, low energy consumption, and is more suitable for family and commercial purposes.

Warm prompt:

If your product is improved product, it may not be totally same as that in the instructions. But it will not change the performance and method of application. Please feel relieved about usage.

Certain space shall be left around the refrigerator, shown in the figure.

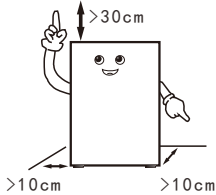

During handling, the door side of the refrigerator shall not contact with the handling tools

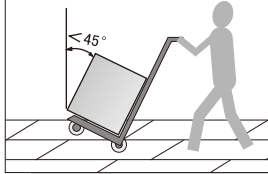

The refrigerator shall be placed in an environment which is dry, has good ventilation, far from direct sunshine and heat source.

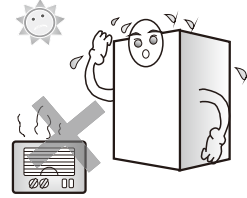

The refrigerator shall be placed on the flat and firm surface. If the ground is not flat, adjust the adjusting leg to keep it level.

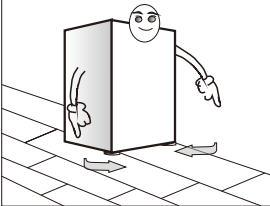

Never place the refrigerator into a too cold environment that may get frozen.

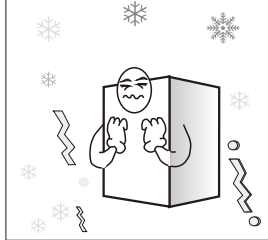

Removing the foam base is beneficial for bottom heat dissipation and can avoid fire.

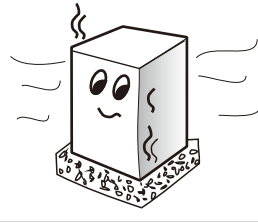

Warm prompt:

--When handling the refrigerator, at least two persons are required - one lifts the top of rear part, the other one handles the bottom (if one part is clamped, it is quite dangerous and may cause accident).

--When moving the refrigerator, the lower runner may damage and scratch the floor. If you need to move the refrigerator for a long distance, the internal accessories shall be fixed using adhesive tape. Otherwise, the accessories may get damaged due to crashing each other.

--Please place the refrigerator in the position with small vibration or little exposed to vibration. For users in the area where earthquake often occurs, please fix the refrigerator against the wall or pole. Otherwise, the falling of refrigerator will cause accident.

--Sufficient clearance shall be left around. If the clearance is too small or place goods on the top or close to the side, or paste on the sides, the heat dissipation of refrigerator will be affected, and thus to cause unnecessary electric energy waste as well as burn out of the wall and other goods; the contact between the back and wall will cause vibration and noise;

--Adjust the front part and adjusting leg of the refrigerator to level it. Unlevel of the refrigerator will cause vibration and noise.

Handling and placement

EN

The outline dimension of the product and the space needed by the use of product are shown in the following pictures.

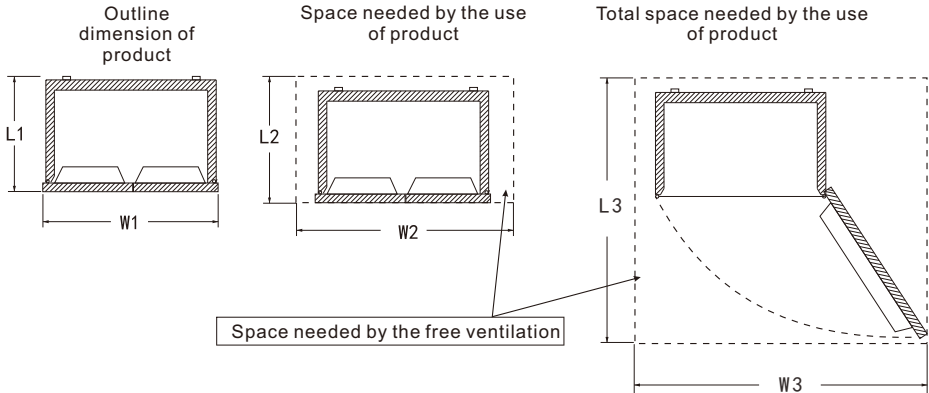

Unit: mm

Product model	Outline dimension of product		Space needed by the use of product		Total space needed by the use of product	
	L1	W1	L2	W2	L3	W3
RB275GM1110	615	545	$>L1+100$	$>W1+200$	$>L1+600$	$>W1+400$

Preparations prior to use

1. Remove all packing assemblies such as case fixing tape etc., especially the foam base.
2. Use warm wet cloth to clean both interior and exterior of the refrigerator, (neutral detergent can be added in warm water).
3. After leveling and cleaning the refrigerator, stand it for about 5 hours before plugging the power plug for powering on, and cool the refrigerator for 2 to 3 hours before storing foods.

1. Remove fixing tape

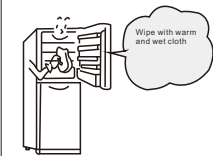

In hot summer, 24 hours are needed to fully freeze the food. Check the refrigerating condition on the second day.

2. Connect to power



3. Store food after connecting to power for 2-3 hours

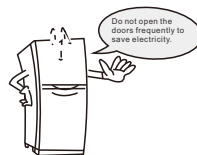

The plastics deodorant will disappear automatically after freezing for a while.

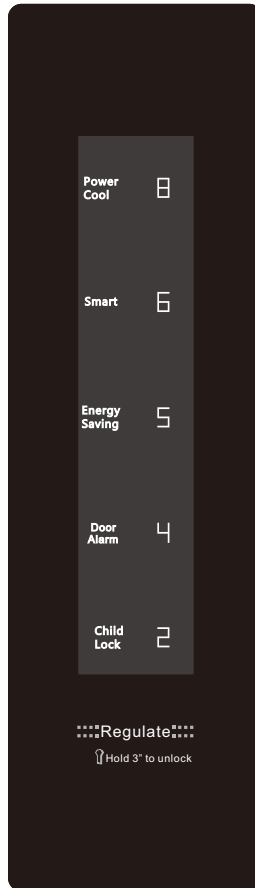
Operation and diagram of display board

The above is the computer control board of the product

Power on for the first time

The first time the power is turned on, the refrigerator runs in 5 speeds.

Child lock function

When there is no key operation in the display for 30 seconds, the child lock function is automatically turned on and the display enters the screen saver mode. In the screen saver mode, the display goes out and the display is awakened by pressing the button for the first time.

When the child lock function is turned on, press and hold the "Temperature Control" key for 3s to unlock the keyboard and the keys are valid.

Gear adjustment

When the child lock function is turned off, press the "Temperature Control" key repeatedly. The refrigerator compartment position is Cycle between "02" → "04" → "05" → "06" → "08" → "power cool" → "smart" → "energy saving" → "02", select the appropriate gear to stop the operation and wait for 5 seconds, the gear is confirmed.

Power cool function

In the unlocked state, press the "Temperature" key repeatedly until the "power cool" icon flashes, stop the key operation and wait for 5 seconds, temperature 2°C under "power cool" function.

Smart function

In the unlocked state, press the "Temperature" key repeatedly until the "smart" icon flashes. Stop the key operation and wait for 5 seconds. temperature 5°C under "smart" function.

Energy saving function

In the unlocked state, press the "Temperature Control" key repeatedly until the "energy saving" icon flashes. Stop the key operation and wait for 5 seconds to enter energy saving. refrigerator room temperature 6°C under "energy saving" function.

Power-off memory

When the power is cut off, the instantaneous working state of blackout will be locked and resume the state after power on.

Door alarm

When the refrigerator or freezer door is not well closed or open for over 1 minute, the buzzer siren will send off sound. Press down any key to stop alarming and the siren sounds "beep, beep, beep" again after 1 minute;

Display protection function

The refrigerator will enter display protection function without any key operation for 30 seconds, and the key board is locked automatically. Under display protection mode, press any key to exit display protection function.

Damper adjustment paddle

Damper adjustment dial adjustment principle behind the refrigerating drawer: Usually we recommend using it in the mid-range.

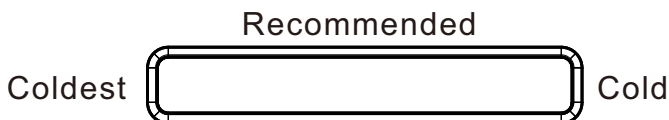

When the temperature in the box varies with the opening and closing of the refrigerator, the ambient temperature, and the place where it is placed, etc.

Refrigerator temperature adjustment

When the damper adjustment blade is adjusted to the "cold" side, the amount of cold airblowing to the refrigerating compartment can be increased to achieve a better refrigerating compartment cooling effect.

Freezer temperature adjustment

When the damper blade adjustment is adjusted to the "coldest" side, the amount of air blowing to the refrigerating compartment is reduced, which will extend the compressor operating time and enhance the refrigeration effect of the freezing compartment.

Operation keys

Foods storage

Refrigerating chamber (2°C~8°C)

--The refrigerating chamber is mainly used for storing short-term foods, like milk, eggs and bottled drink.

--Vegetables, melons and fruits shall be put into the fruit and vegetable box to prevent water loss.

--The cooked foods shall be put into the refrigerator after packaging with the preservative bags, to prevent the back from frosting and the power from increasing.

Freezing chamber (-22°C~-15°C)

--The freezing chamber is used for the foods to be stored for long-term.

--Fish and meat to be frozen shall be cut into small pieces, packaged with preservative bags separately and then put into the frozen drawer.

--The glass container or the sealed container filled with liquid shall not be stored in the freezing chamber, to prevent the risk of burst due to freezing.

--The fresh foods shall not be stored together with the frozen foods.

--Do not place food close to inside wall in freezer lest food and wall should be frozen together.

★★ Warm tips:

The stored food, if any, shall not block the air duct outlet and return port for fear of affecting the refrigerating effect.

Before being stored in the refrigerator, the overheated water and food shall be cooled to the room temperature.

Ice-making (If the appliance has it)

Fill the ice-making box with 4/5 water and put the box into the freezing chamber. After the water in the box turns into ice, twist the box slightly to separate the ice from the box. However, don't bend the box. When separating the ice, wrap the box with dry box to avoid finger frostbite.

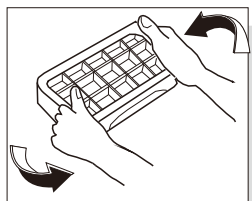

Operation notes

EN

Before reversing the door, please prepare the following tools: cross screw driver, wrench. Note: please remove the main plug before reversing the door. Two people may be needed.

1. Close the door, take out the screw from the upper hinge cover with a cross screw driver, remove the hinge cover, and then disassemble the connection terminal, screw off the top hinge, and take down the door. Remove the screw cover on the left.

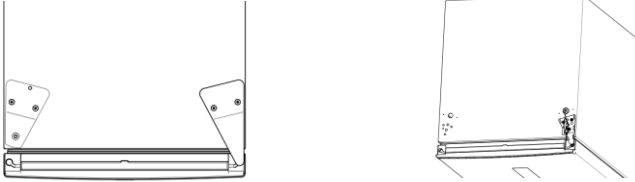

2. Take out the screws of the middle hinge with a cross screwdriver, remove the middle hinge, remove the screw cover at the left screw hole, and take down the lower door.

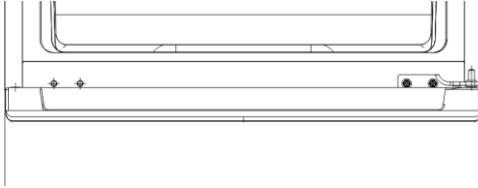

3. Laying down the refrigerator, and remove the lower hinge and leveling angle at the bottom of the refrigerator.



4. Remove the wire cover of the upper upper door cover, change the wiring harness from the right side to the left side, install the wire cover of the upper end cover, and change the upper door and lower door stop to the left side. (the replacement of upper door and lower door stop is the same as that of lower door, and the lower left figure will be changed to right picture)

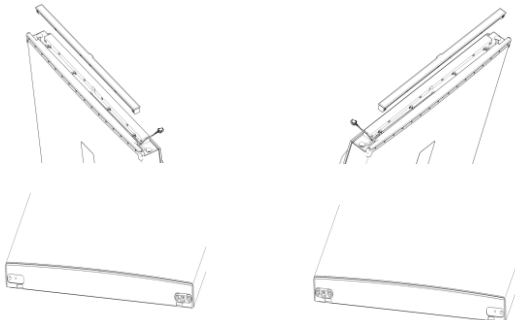

5. Disassemble the lower hinge assembly, and then install the leveling foot and screw nut (as shown in the right figure).

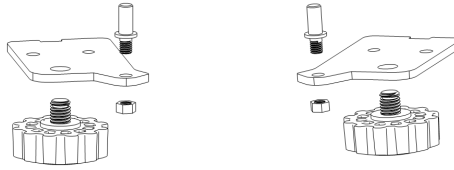

6. Replace the lower hinge assembly with the leveling angle, and install the lower door.

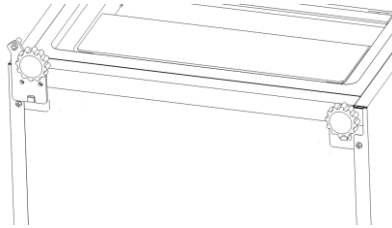

7. Install the middle hinge at the left mounting position, and install the previously removed screw cover to the right screw hole.

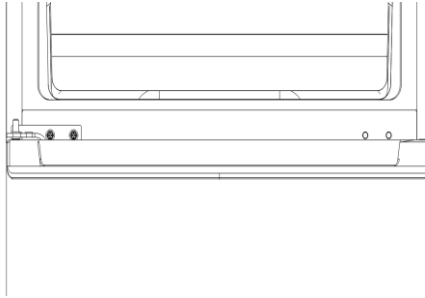

8. Install the door, connect the terminals, install the upper hinge, the upper hinge cover and the previously removed screw cover. Reverse door complete. (the upper hinge and hinge cover are installed on the left as shown in the figure, and the screw cover is in the right position)



9. After the operation is completed, please stand still for a period of time and turn on the power.

Disassembly and assembly method of accessory

--Glass shelf in the refrigerating chamber: the height of the shelf is adjustable, which facilitates the storage of articles with different volumes. Pull the shelf outwardly and upwardly in a slight way to take out.

--Fruit and vegetable box: for storing vegetables and fruits. It can be taken out by pulling outwardly.

--Drawer in the freezing chamber: storing foods to be preserved for long-term, such as meat and fish. It can be taken out by pulling outwardly and lifting upwardly.

Kindly tips: It is recommended to put into the large piece of meat after being cut into small pieces, to avoid difficult cutting after being frozen. The quick-freezing foods shall be distributed uniformly and stored together after being frozen.

--Bottle pedestal at the refrigerating door: storing eggs, various bottled drinks and other sundries. It can be taken out by being lifted up slightly.

Note: Don't pull out the bottle pedestal at the refrigerating door forcibly during disassembly, to avoid damaging the refrigerator.

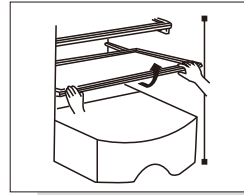

Take out by pulling upwardly and outwardly in a slight way

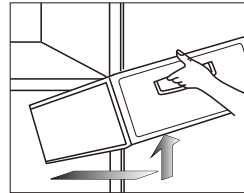

Take out by pulling outwardly and upwardly in a slight way

Maintenance

It is suggested to maintain the refrigerator once per month;

--Unplug the power plug to prevent from electric shock;

--Use wet cloth or neutral detergent (cleanser essence) to wipe off the oil contamination and other dirt. Then completely wipe off the detergent.

--Do not use alkaline detergent, soap powder, gasoline and alcohol, talcum powder etc.; otherwise the coats or plastics may be damaged;

--Regularly clean the refrigerator body and clear the ground dusts to keep the refrigerator clean.

Inspections after maintenance:

1. Whether there are damages to the power line and plug;
2. Whether there are dusts on the power plug;
3. Whether there is abnormal heat on the plug;
4. Whether the socket is loose; 5. Whether the plug is totally inserted.

Note:

If the power line and plug is damaged and there exist dusts, electric shock or fire may occur;

After unplugging the plug, 5 minutes must pass before re-plugging it;

Do not put your hands under the refrigerator to avoid getting hurt.

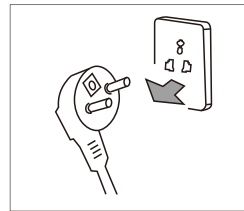

Unplug the refrigerator plug before cleaning



Please use neutral detergent

The following items shall be inspected before occurring failures which require maintenance:

Failures: Refrigerator does not work, the refrigeration effect is poor

Causes: 1. Check the connection of power supply. 2. Check whether the refrigerator is exposed to direct sunlight or whether there is heat source nearby. 3. Check whether there is heat dissipation space around refrigerator.

Remedies: 1. Connect the power supply. 2. Move the refrigerator to a place without direct sunlight and heat source. 3. Leave sufficient space between refrigerator and wall.

Failures: Foods in refrigerating chamber are frozen

Causes: 1. Check whether the setting temperature is too low. 2. Check whether foods with too much water are too close to the rear wall.

Remedies: 1. Adequately increase the temperature. 2. Move the foods with too much water to the door side of glass shelf

Failures: There is abnormal sound in refrigerator

Causes: 1. Check whether the bottom of refrigerator is stable. 2. Check whether the refrigerator is too close to the wall. 3. Check whether the refrigerator touches other objects.

Remedies: 1. Adjust the bottom adjusting leg to stabilize the refrigerator. 2. Leave sufficient space around refrigerator. 3. Remove the obstacles.

Failures: There is abnormal odor in refrigerator

Causes: 1. Check whether the foods are sealed for storage. 2. Check whether the refrigerator is clean. 3. Check whether the foods are stored for too long time.

Remedies: 1. Sealed foods for storage. 2. Regularly clean the refrigerator. 3. Do not store foods for too long time.

Non-failures

Phenomenon: Fever or hot on two sides and spacing part surface between refrigerating chamber and freezing chamber.

Cause: Refrigerator pipes (condenser, anti-fog pipes) are on two sides and front part of refrigerator for heat dissipation and to prevent from condensation.

Phenomenon: The door is too tight and not easy to open

Cause: Reopening of the door immediately after closing it is hard because hot air enters the refrigerator and contracts to produce pressure difference. It is easy to open the door after a while.

Phenomenon: There is water ripple in refrigerator

Cause: When starting or stopping the compressor, the refrigerant will make such sound; Water produced after defrosting will also make such sound.

Phenomenon: There is "Click" sound or tick sound in refrigerator

Cause: Shrinkage and swelling of case will make such sound; When the case is cold or the door is opened, this sound will occur; Phenomenon: There is hum sound in refrigerator

Cause: Running of compressor will make such sound (if the refrigerator is not leveled, this sound will be louder)

Phenomenon: There is condensation or frosting freezing chamber door surface or food surface

Cause: Temperature or humidity around the refrigerator is high; The door is opened for too long time; The foods with too much water are not sealed or tightly wrapped

Phenomenon: There is condensation on the built-in light surface

Cause: Light will produce heat after being lit, and the door is opened for too long time. So there is temperature difference, and thus the light case will have condensation.

Phenomenon: There is condensation and water mist on body

Cause: Humidity around refrigerator is high, and the moisture in the air will gather in the case to form condensation

Technical parameter

EN

Model	RB275GM1110						
Climate type	N/ST/T						
Electric shock resistance	I						
Star sign							
Total Storage Volume	275L						
Storage Volume of Freezer	72L						
Power type	220-240V~50Hz						
Rated current	0.7A						
Power consumption	0.76kW·h/24h						
Lamp power	1.5W						
Weight	55kg						
Dimension	545x615x1825						
Refrigerant and charge amount	R600a,54g						
Noise Volume	42dB(A)						

Packing list

Annex	Model	RB275GM1110					
Refrigerating shelf		3					
Fruit and vegetable box cover		1					
Fruit and vegetable box		1					
Ice-making box		1					
Egg box		1					
Refrigerating door bottle bracket		3					
Freezing drawer		3					
Operating instruction		1					

Material number: 8B110-000806
Edition: 202006-A.1

Ovaj dokument je originalno proizveden i objavljen od strane proizvođača, brenda TCL, i preuzet je sa njihove zvanične stranice. S obzirom na ovu činjenicu, Tehnoteka ističe da ne preuzima odgovornost za tačnost, celovitost ili pouzdanost informacija, podataka, mišljenja, saveta ili izjava sadržanih u ovom dokumentu.

Napominjemo da Tehnoteka nema ovlašćenje da izvrši bilo kakve izmene ili dopune na ovom dokumentu, stoga nismo odgovorni za eventualne greške, propuste ili netačnosti koje se mogu naći unutar njega. Tehnoteka ne odgovara za štetu nanesenu korisnicima pri upotrebi netačnih podataka. Ukoliko imate dodatna pitanja o proizvodu, ljubazno vas molimo da kontaktirate direktno proizvođača kako biste dobili sve detaljne informacije.

Za najnovije informacije o ceni, dostupnim akcijama i tehničkim karakteristikama proizvoda koji se pominje u ovom dokumentu, molimo posetite našu stranicu klikom na sledeći link:

<https://tehnoteka.rs/p/tcl-kombinovani-frizider-rb275gm1110-akcija-cena/>