

Uputstvo za upotrebu

PHILIPS stajler za kosu BHB872/00

PHILIPS



Tehnoteka je online destinacija za upoređivanje cena i karakteristika bele tehnike, potrošačke elektronike i IT uređaja kod trgovinskih lanaca i internet prodavnica u Srbiji. Naša stranica vam omogućava da istražite najnovije informacije, detaljne karakteristike i konkurentne cene proizvoda.

Posetite nas i uživajte u ekskluzivnom iskustvu pametne kupovine klikom na link:

<https://tehnoteka.rs/p/philips-stajler-za-kosu-bhb87200-akcija-cena/>

Register your product and get support at www.philips.com/welcome

BH8872



EN User manual	LV Lietotāja rokasgrāmata
BG Употреба по инструкции	PL Instrukcja obsługi
CS Příručka pro uživatele	RO Instrucțiunile de utilizare
ES Guía del usuario	RU Руководство пользователя
ET Kasutusjuhend	RU Руководство пользователя
HR Korisnički priručnik	SK Použitie a údržba
HU Felhasználói kézikönyv	SI Uporabni priročnik
KK Қолданушының нұсқаулығы	SF Korisnički priručnik
LT Vartotojų vadovas	UK Полюбов користувача

PHILIPS



Specifications are subject to change without notice © 2016 Koninklijke Philips NV. All rights reserved.

English

Congratulations on your purchase, and welcome to Philips. To fully benefit from the product, please read this user manual carefully before you use the appliance and keep it for future reference.

- WARNING:** Do not use this appliance near water.
- When the appliance is used in a bathroom, unplug it after use since the proximity of water presents a risk, even when the appliance is switched off.

- WARNING:** Do not use this appliance near bathtubs, showers, basins or other vessels containing water.
- Always unplug the appliance after use.

- WARNING:** Do not use this appliance near bathtubs, showers, basins or other vessels containing water.
- Always unplug the appliance after use.
- If the mains cord is damaged, you must have it replaced by service centre or similarly qualified persons in order to avoid a hazard.
- This appliance can be used by children aged from 8 years and above and persons with reduced physical, sensory or mental capabilities or lack of experience and knowledge if they have been given supervision or instruction concerning use of the appliance in a safe way and understand the hazards involved. Children shall not play with the appliance. Cleaning and user maintenance shall not be made by children without supervision.

- Before you connect the appliance, ensure that the voltage indicated on the appliance corresponds to the local power voltage.
- Do not use the appliance for any other purpose than described in this manual.
- Do not use this appliance on artificial hair.
- When the appliance is connected to the power, never leave it unattended.
- Never use any accessories or parts from other manufacturers or that Philips does not specifically recommend. If you use such accessories or parts, your guarantee becomes invalid.

- Do not wind the mains cord round the appliance.
- Wait until the appliance has cooled down before you store it.
- Play full attention when using the appliance since it could be extremely hot. Only hold the handle as other parts are hot and avoid contact with the skin.

- Always place the appliance with the stand on a heat-resistant, stable flat surface. The hot barrel should never touch the surface or other flammable material.
- Avoid the mains cord from coming into contact with the hot parts of the appliance.
- Keep the appliance away from flammable objects and material when it is switched on.

- Never cover the appliance with anything (e.g. a towel or clothing) when it is hot.
- Only use the appliance on dry hair. Do not operate the appliance with wet hands.
- Keep the barrel clean and free of dust and styling products such as mousse, spray and gel.

- The barrel has coating. This coating might slowly wear away over time. However, this does not affect the performance of the appliance.
- If the appliance is used on color-treated hair, the barrel may be stained.
- Always return the appliance to a service centre authorized by Philips for examination or repair.

- Repair by unqualified people could result in an extremely hazardous situation for the user.
- Do not insert metal objects into openings to avoid electric shock.
- Do not pull on the power cord after using. Always unplug the appliance by holding the plug.

Electromagnetic fields (EMF)

This Philips appliance complies with all applicable standards and regulations regarding exposure to electromagnetic fields.

Environment

This symbol means that this product shall not be disposed of with normal household waste (2012/19/EU). Follow the user's manual for the separate collection of electrical and electronic products. Correct disposal helps prevent negative consequences for the environment and human health.

2 Introduction

The Glam Shine Curler, our first curler with ionic care and titanium enamel barrel for glossy/smooth shiny curls and curls. Unique **Cur Ready Indicator** helps you create beautiful curls and protects from overheating.

- Key Function** = auto-adjusted to 5 seconds, and the key lock on is activated automatically and the key lock on will be displayed (D). The first automatic activation after switching on the appliance is after 15 seconds. To unlock the appliance, press the **(E)** for 1 second.

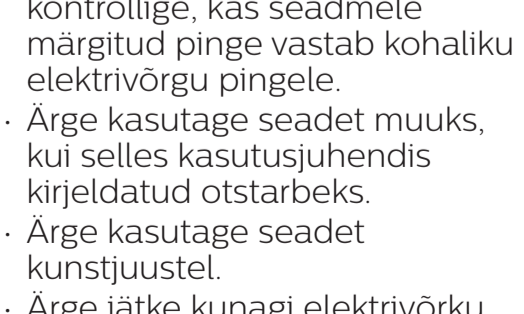
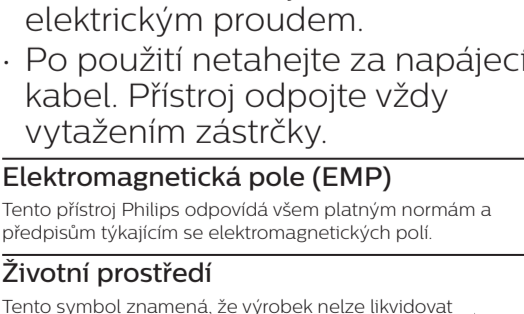
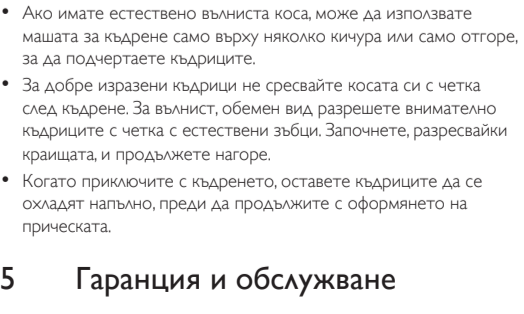
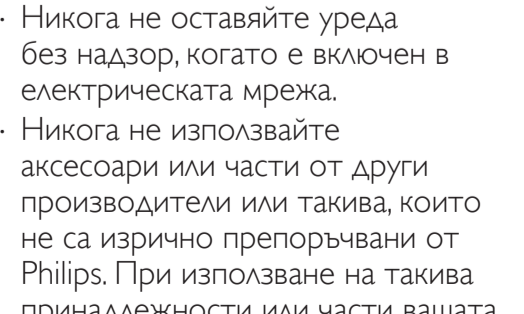
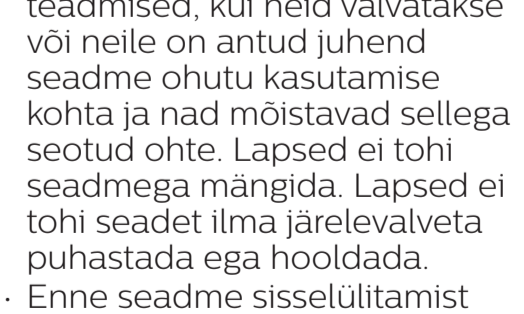
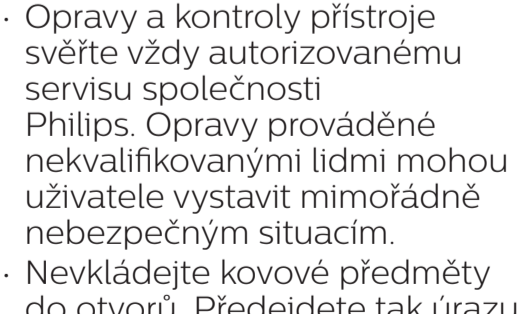
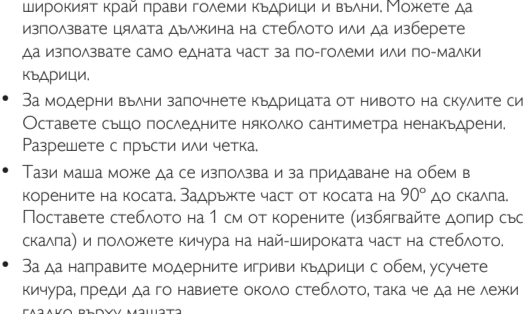
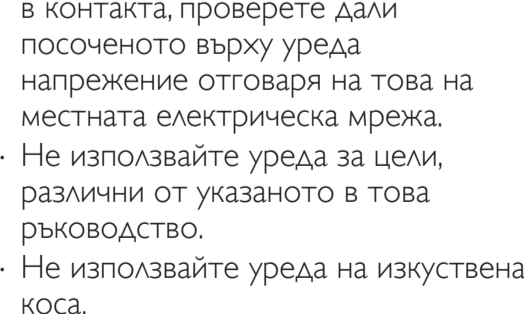
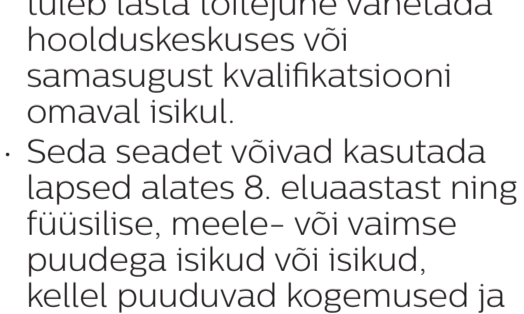
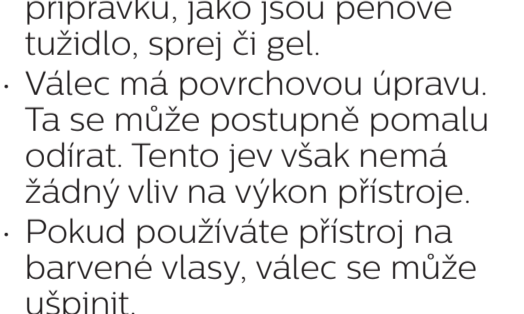
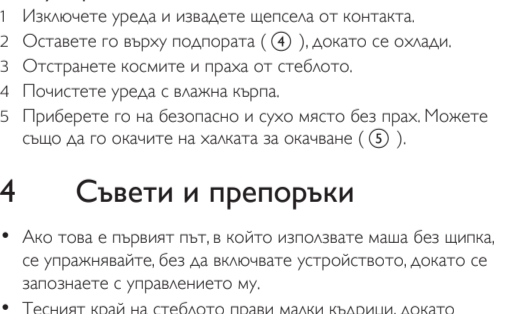
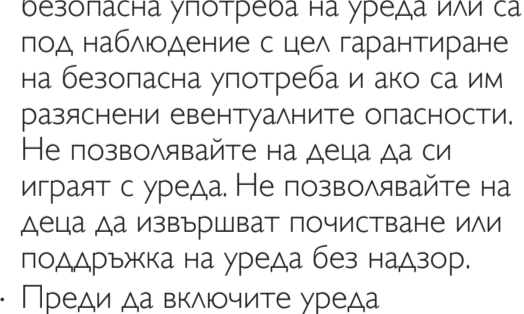
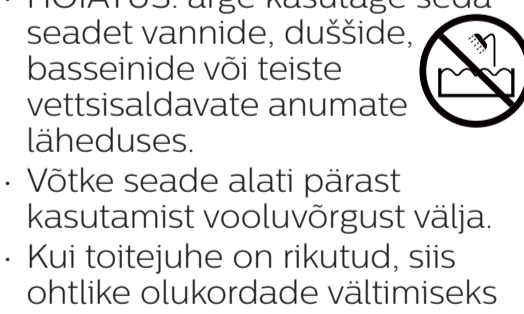
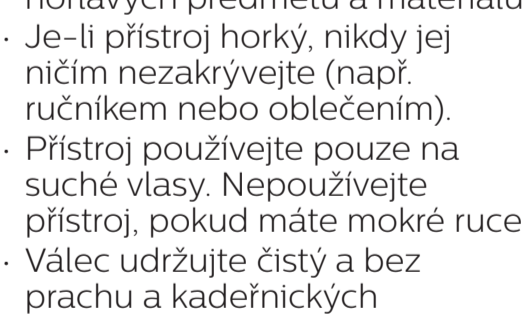
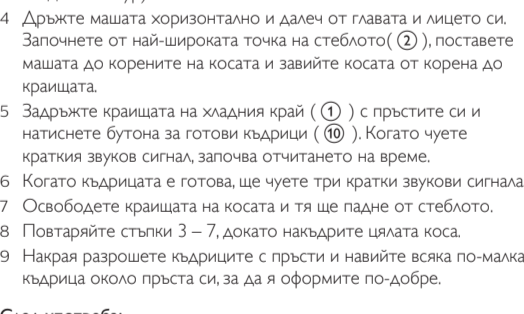
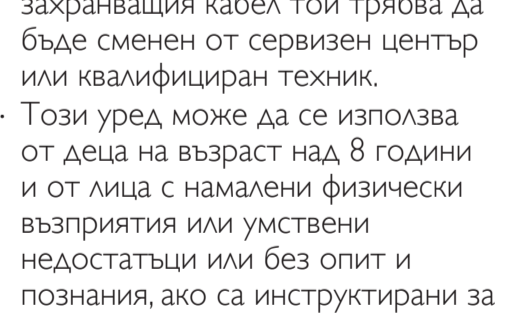
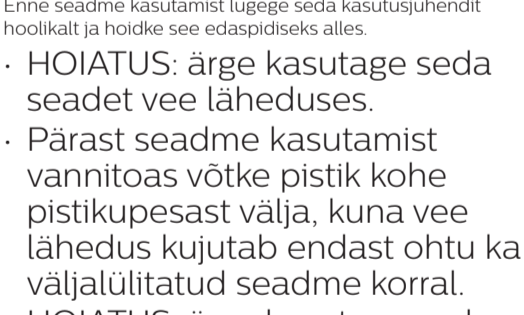
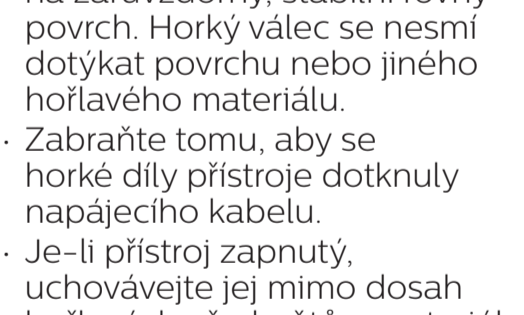
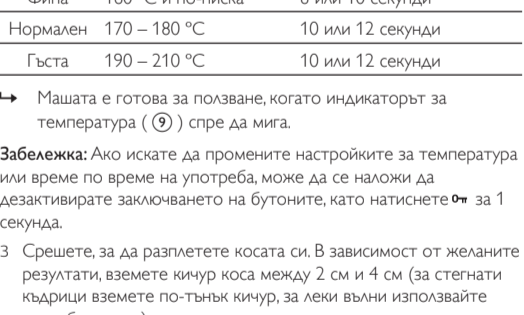
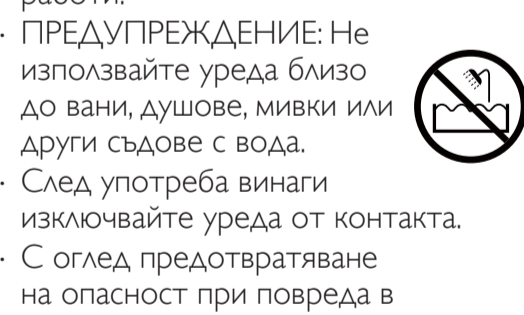
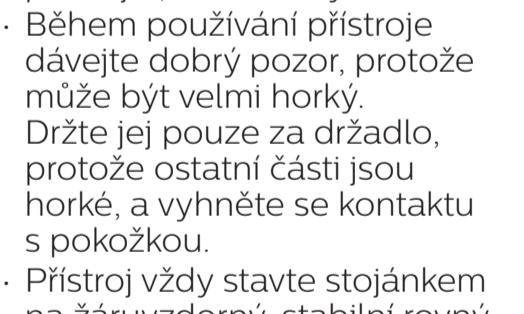
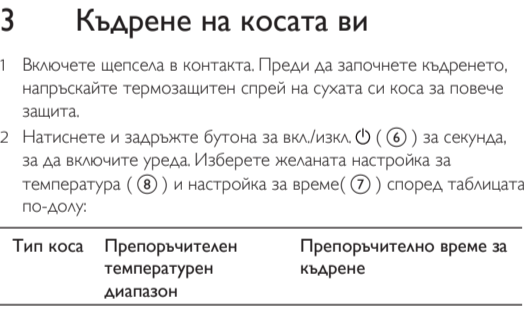
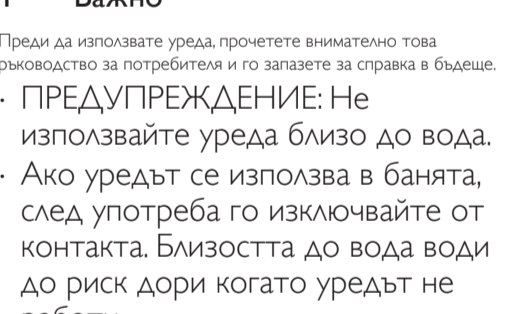
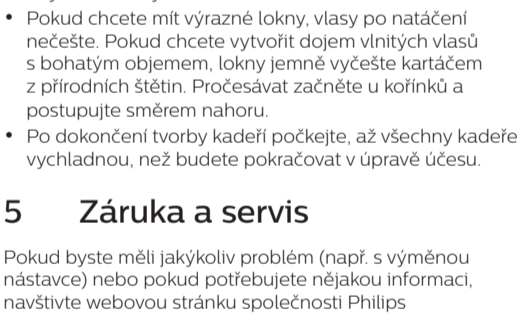
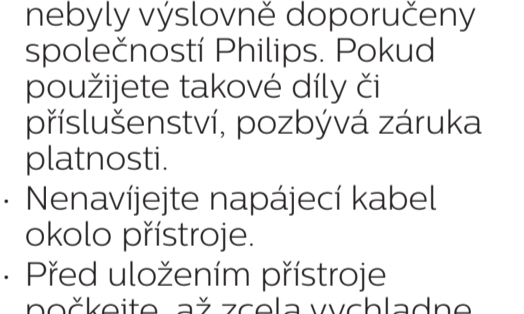
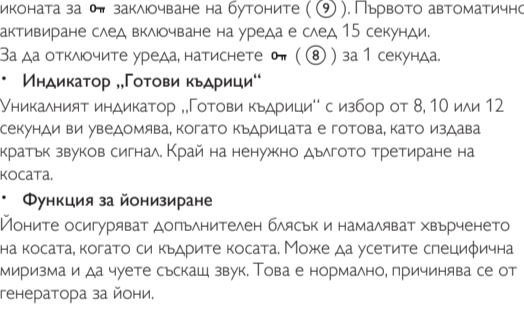
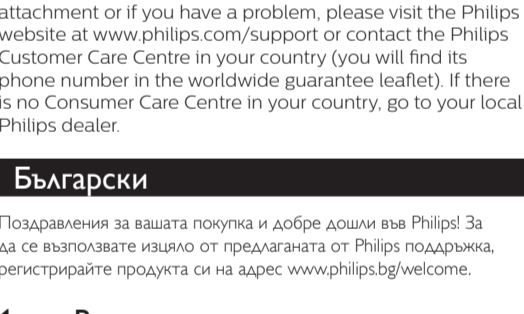
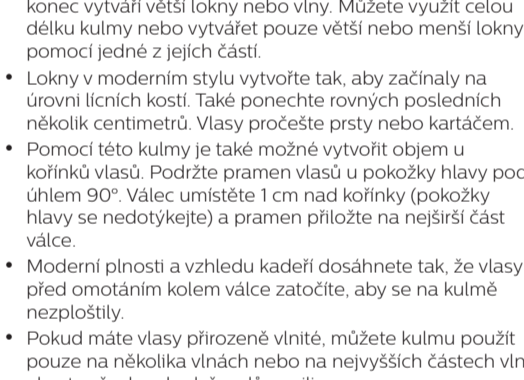
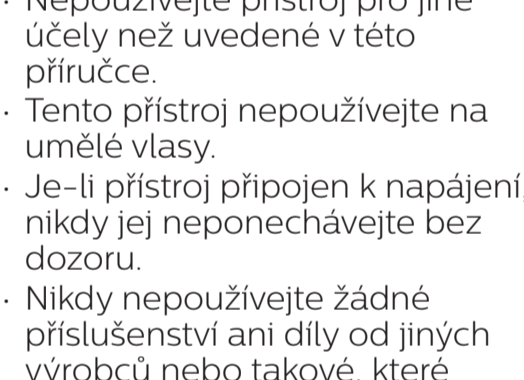
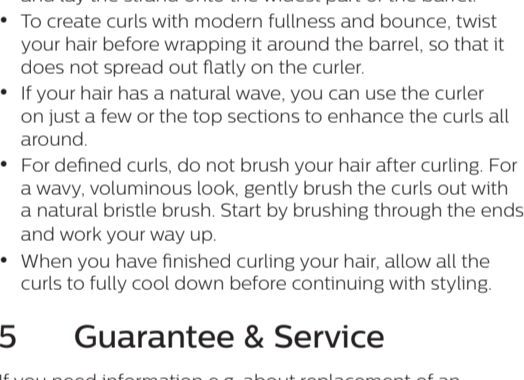
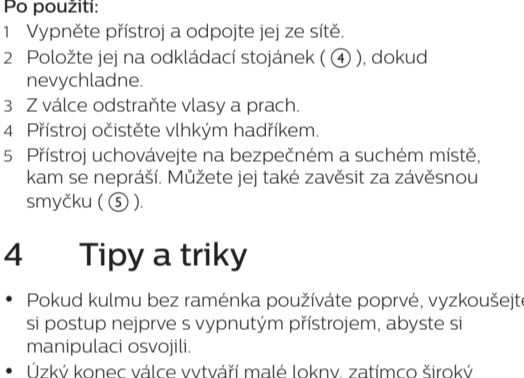
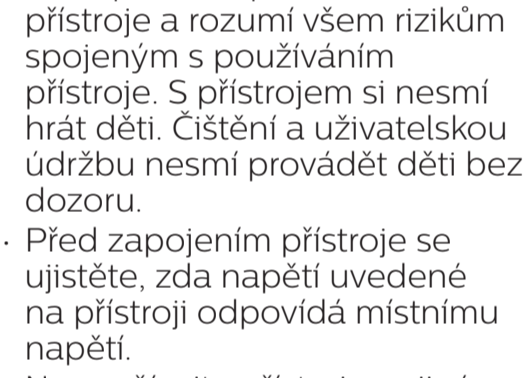
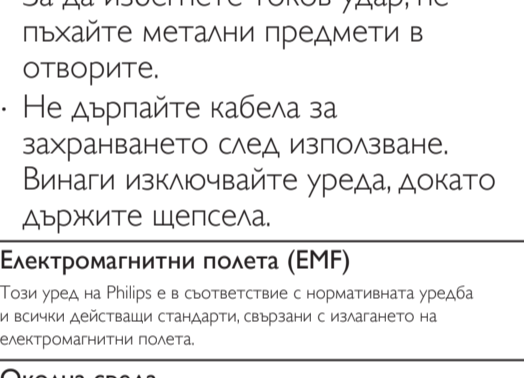
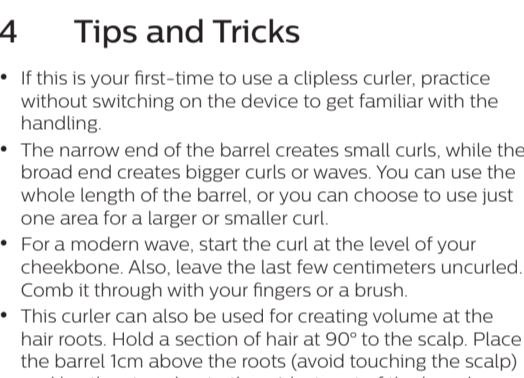
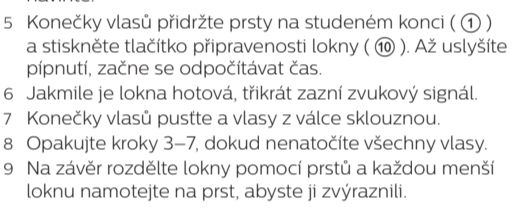
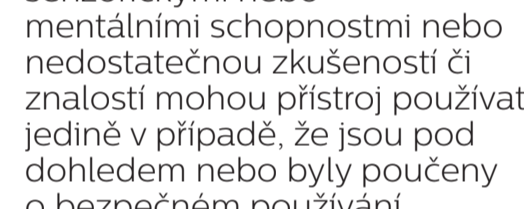
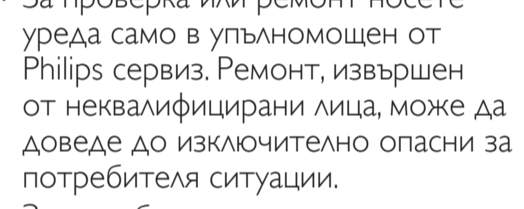
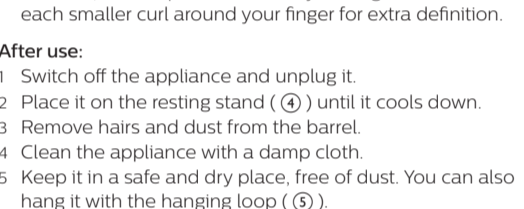
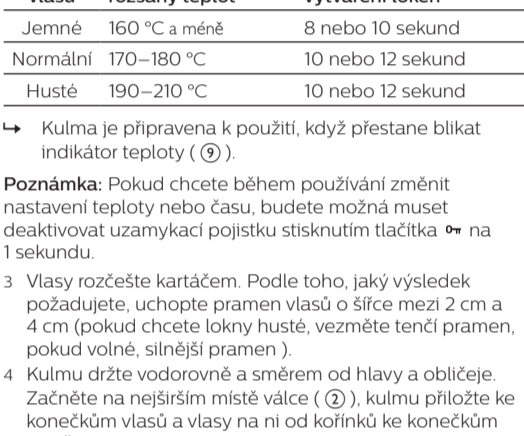
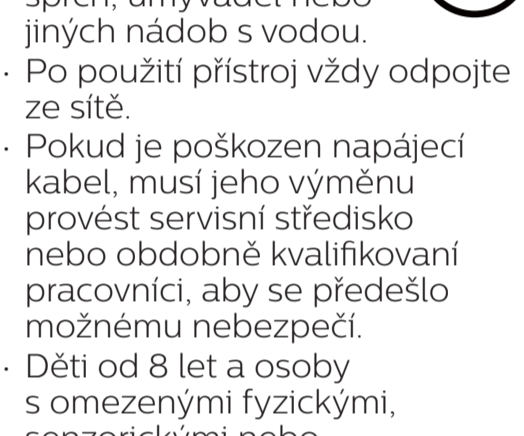
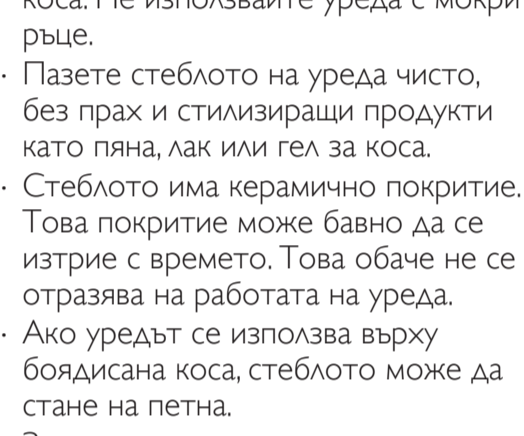
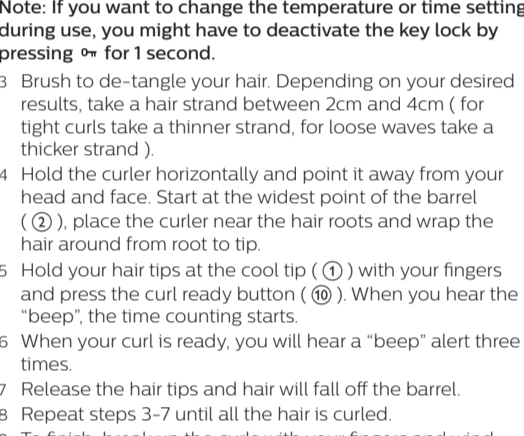
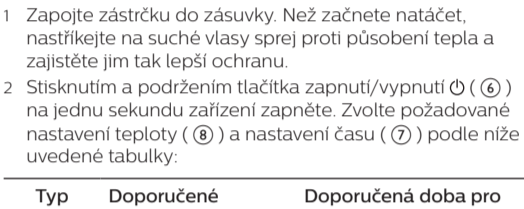
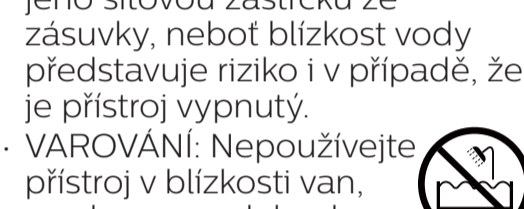
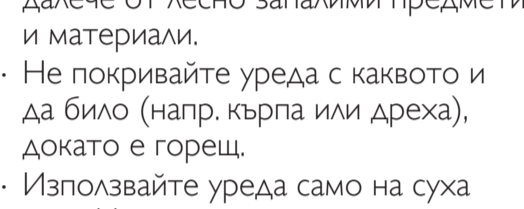
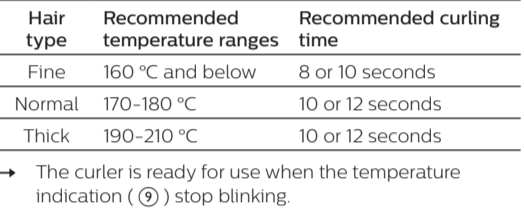
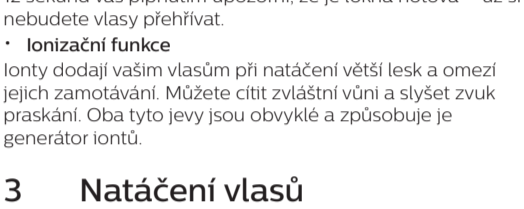
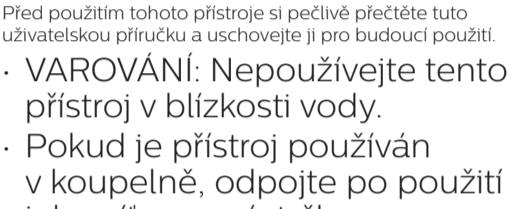
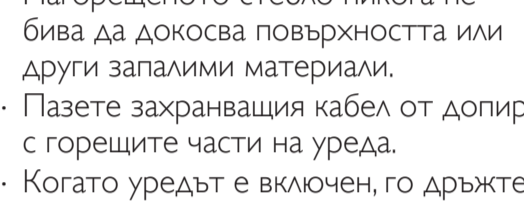
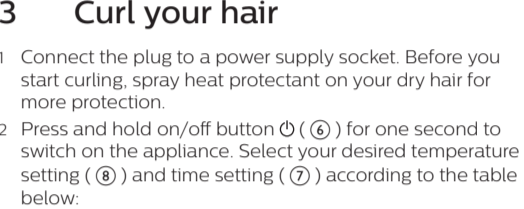
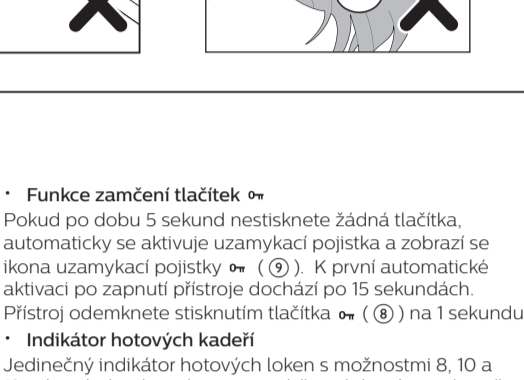
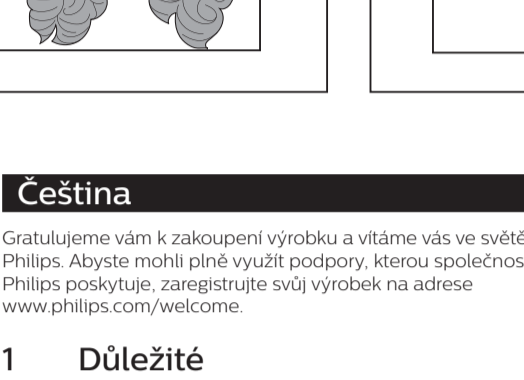
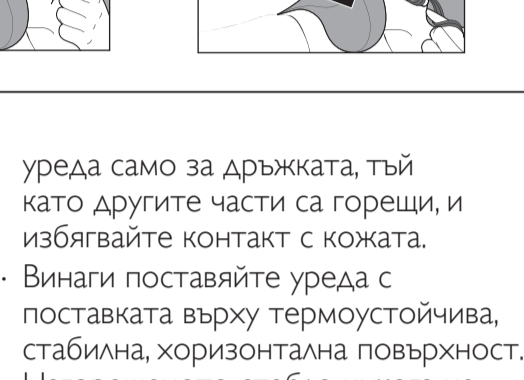
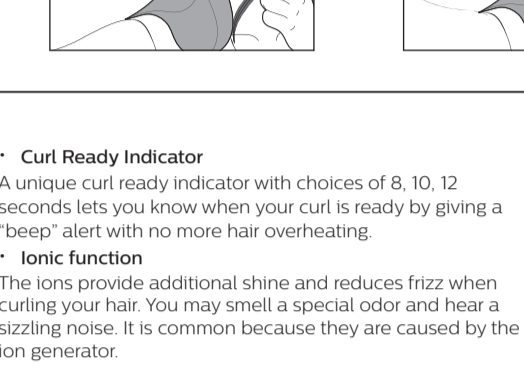
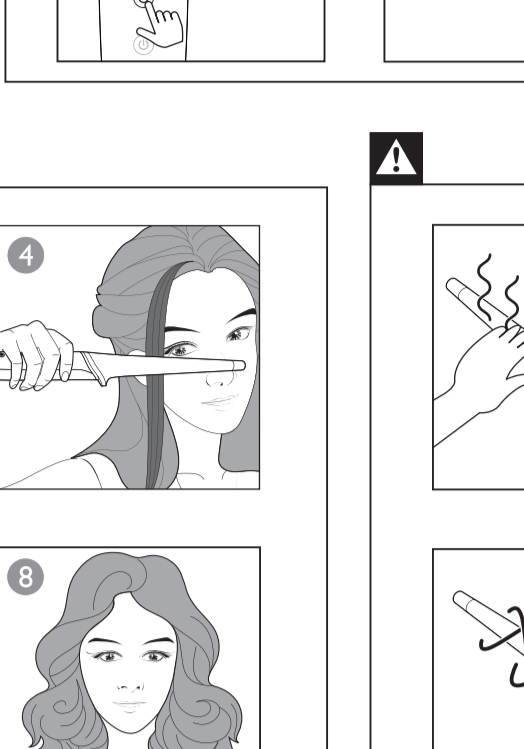
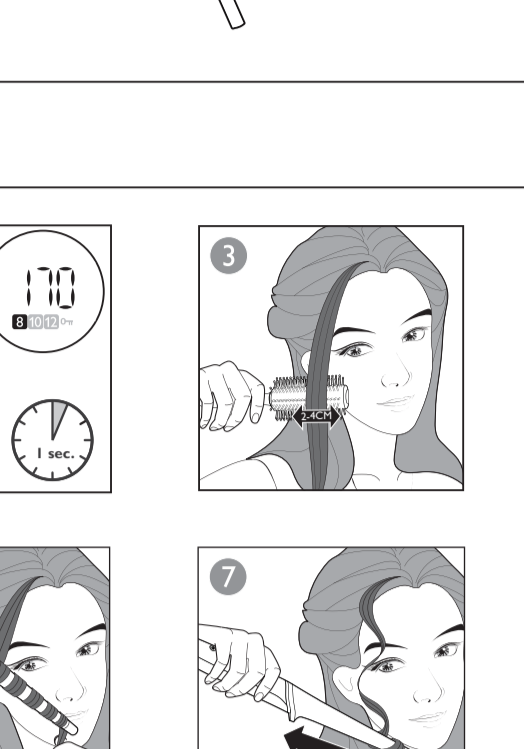
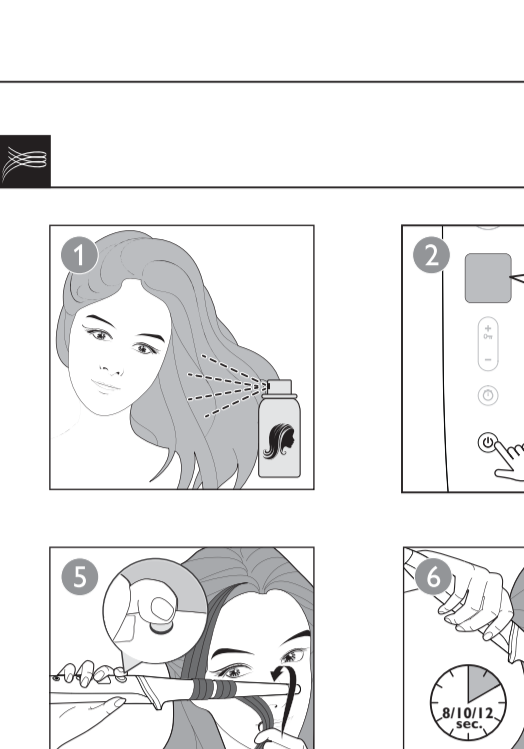
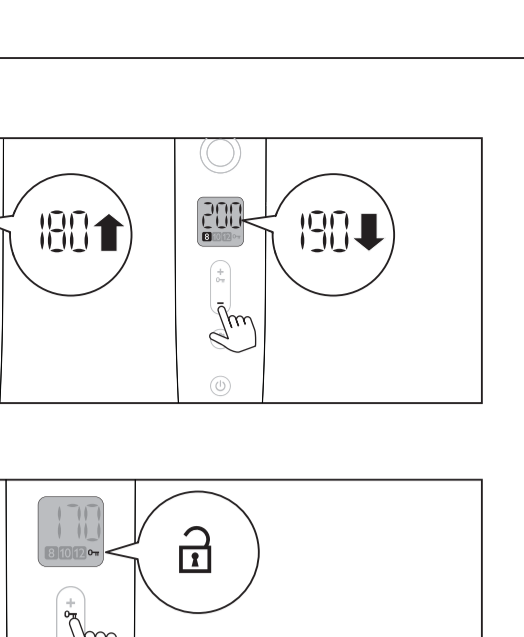
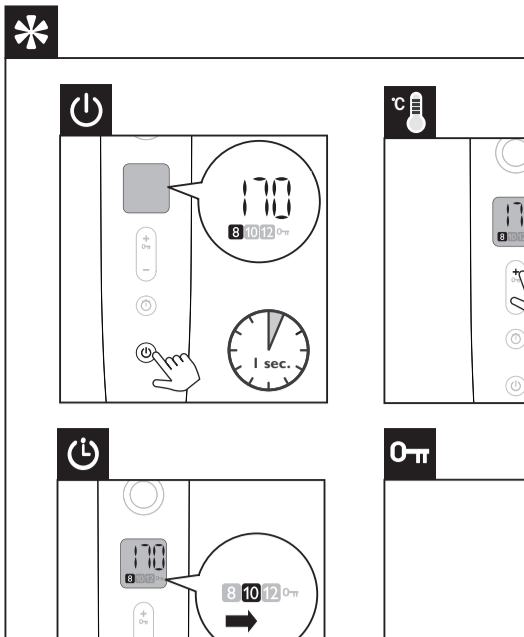
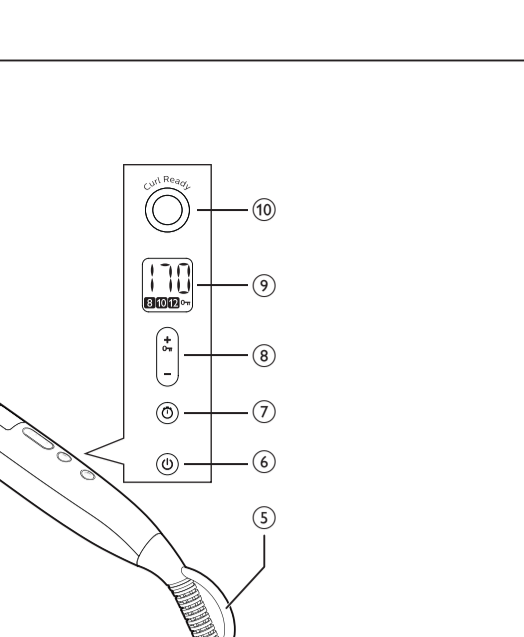
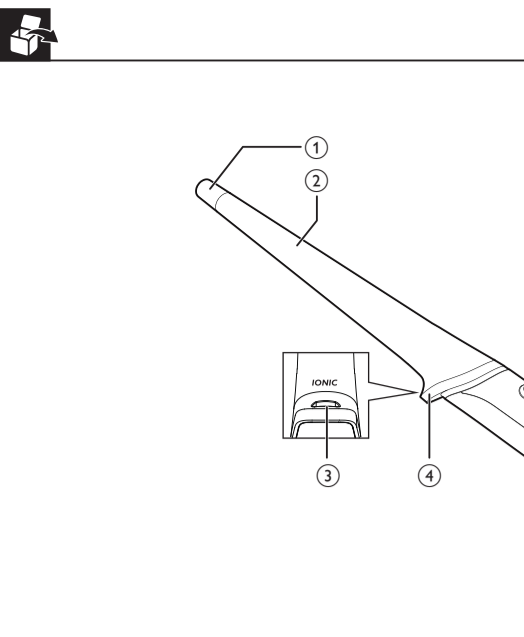

The Glam Shine Curler, our first curler with ionic care and titanium enamel barrel for glossy/smooth shiny curls and curls. Unique **Cur Ready Indicator** helps you create beautiful curls and protects from overheating.

- Key Function** = auto-adjusted to 5 seconds, and the key lock on is activated automatically and the key lock on will be displayed (D). The first automatic activation after switching on the appliance is after 15 seconds. To unlock the appliance, press the **(E)** for 1 second.

urda samo za drzjakata, tvoj mat drugite cista sa goroshi, i izabirajte kontakt s kosom. • Vinagri postavite ureda s postavkama vrhu termoosusivnava, stabilnija, horizontalnija povrhnost. • Nagorjelo stelo nikogada ne biva da dokosa povrhnostima ili drugi zapaljivim materijali. • Plazete zakrpanjivaa kabea ot dopir s gorajete cista na ureda. • Kogato uradete e vkljucen, go drzajte delate ot lesno zapaljivim predmeti i materijali. • Ne pokrivajte ureda s kavekoto i da bivo (napr. kupa ili areka), dokozate go resh. • Izpolzavajte ureda samo na suha kosa. Ne izpolzavajte ureda s mokrija rya. • Plazete stebeloto na ureda cisto, bez praz i stizmirajaci produkti kao piva, lak ili gic za kos. • Stebeloto imi keraminno pokrivite. Tova pokrivite moze bavno da se izotvori ot gorajete stidkiko, nebo obdoben kvalifikovani pracovnici, ali se predeso mozno ne. • Ako uradete se izpolzava vrhu bodjavnica kosa, stebeloto moze da stane na petna. • Za provjera ili remont nosete ureda samo u yemioncent ot Philips servis. Remont, izvrsen ot nekvalificiranih lica, moze da dovede do iznikotnevat opasni za potrebiteln situaciji. • Za da izbegnete tokov udar, ne pihajte metalni predmeti v otvorite. • Ne drpajte kabea za zakrpanjevo SAMA, izpolzovane. Vinagri iznikotvajte ureda, dokozat drzjete sheska.

urda samo za drzjakata, tvoj mat drugite cista sa goroshi, i izabirajte kontakt s kosom. • Vinagri postavite ureda s postavkama vrhu termoosusivnava, stabilnija, horizontalnija povrhnost. • Nagorjelo stelo nikogada ne biva da dokosa povrhnostima ili drugi zapaljivim materijali. • Plazete zakrpanjivaa kabea ot dopir s gorajete cista na ureda. • Kogato uradete e vkljucen, go drzajte delate ot lesno zapaljivim predmeti i materijali. • Ne pokrivajte ureda s kavekoto i da bivo (napr. kupa ili areka), dokozate go resh. • Izpolzavajte ureda samo na suha kosa. Ne izpolzavajte ureda s mokrija rya. • Plazete stebeloto na ureda cisto, bez praz i stizmirajaci produkti kao piva, lak ili gic za kos. • Stebeloto imi keraminno pokrivite. Tova pokrivite moze bavno da se izotvori ot gorajete stidkiko, nebo obdoben kvalifikovani pracovnici, ali se predeso mozno ne. • Ako uradete se izpolzava vrhu bodjavnica kosa, stebeloto moze da stane na petna. • Za provjera ili remont nosete ureda samo u yemioncent ot Philips servis. Remont, izvrsen ot nekvalificiranih lica, moze da dovede do iznikotnevat opasni za potrebiteln situaciji. • Za da izbegnete tokov udar, ne pihajte metalni predmeti v otvorite. • Ne drpajte kabea za zakrpanjevo SAMA, izpolzovane. Vinagri iznikotvajte ureda, dokozat drzjete sheska.

urda samo za drzjakata, tvoj mat drugite cista sa goroshi, i izabirajte kontakt s kosom. • Vinagri postavite ureda s postavkama vrhu termoosusivnava, stabilnija, horizontalnija povrhnost. • Nagorjelo stelo nikogada ne biva da dokosa povrhnostima ili drugi zapaljivim materijali. • Plazete zakrpanjivaa kabea ot dopir s gorajete cista na ureda. • Kogato uradete e vkljucen, go drzajte delate ot lesno zapaljivim predmeti i materijali. • Ne pokrivajte ureda s kavekoto i da bivo (napr. kupa ili areka), dokozate go resh. • Izpolzavajte ureda samo na suha kosa. Ne izpolzavajte ureda s mokrija rya. • Plazete stebeloto na ureda cisto, bez praz i stizmirajaci produkti kao piva, lak ili gic za kos. • Stebeloto imi keraminno pokrivite. Tova pokrivite moze bavno da se izotvori ot gorajete stidkiko, nebo obdoben kvalifikovani pracovnici, ali se predeso mozno ne. • Ako uradete se izpolzava vrhu bodjavnica kosa, stebeloto moze da stane na petna. • Za provjera ili remont nosete ureda samo u yemioncent ot Philips servis. Remont, izvrsen ot nekvalificiranih lica, moze da dovede do iznikotnevat opasni za potrebiteln situaciji. • Za da izbegnete tokov udar, ne pihajte metalni predmeti v otvorite. • Ne drpajte kabea za zakrpanjevo SAMA, izpolzovane. Vinagri iznikotvajte ureda, dokozat drzjete sheska.

urda samo za drzjakata, tvoj mat drugite cista sa goroshi, i izabirajte kontakt s kosom. • Vinagri postavite ureda s postavkama vrhu termoosusivnava, stabilnija, horizontalnija povrhnost. • Nagorjelo stelo nikogada ne biva da dokosa povrhnostima ili drugi zapaljivim materijali. • Plazete zakrpanjivaa kabea ot dopir s gorajete cista na ureda. • Kogato uradete e vkljucen, go drzajte delate ot lesno zapaljivim predmeti i materijali. • Ne pokrivajte ureda s kavekoto i da bivo (napr. kupa ili areka), dokozate go resh. • Izpolzavajte ureda samo na suha kosa. Ne izpolzavajte ureda s mokrija rya. • Plazete stebeloto na ureda cisto, bez praz i stizmirajaci produkti kao piva, lak ili gic za kos. • Stebeloto imi keraminno pokrivite. Tova pokrivite moze bavno da se izotvori ot gorajete stidkiko, nebo obdoben kvalifikovani pracovnici, ali se predeso mozno ne. • Ako uradete se izpolzava vrhu bodjavnica kosa, stebeloto moze da stane na petna. • Za provjera ili remont nosete ureda samo u yemioncent ot Philips servis. Remont, izvrsen ot nekvalificiranih lica, moze da dovede do iznikotnevat opasni za potrebiteln situaciji. • Za da izbegnete tokov udar, ne pihajte metalni predmeti v otvorite. • Ne drpajte kabea za zakrpanjevo SAMA, izpolzovane. Vinagri iznikotvajte ureda, dokozat drzjete sheska.

- Arge kerige toitejuhet umber seadme.
- Enne hoikonta panekut laske seadme taeliikut maha jahtuda.
- Olge seadme kasutamisel vaga tahelepantaku, kuna see voib olla armsitum kuum. Hoideki kinni uknses kaepidemist, kuna teised osad on kuunud. Valtige kokkupuudet nahaga.

- Asetage seade kose alusega alati kuumakindlale stabiilese tasasele pinnale. Kuumat teki et tohi kurnat, kuna teki ega muudeti toitejuhet materjalidega kokku puutuda.
- Arge laske toitejuhet vastu seadme kuumi osi minna.
- Hoideke sisselulitatud seadet kergeti suttivatset objektidest ja materjalidest kaugemal.
- Kunagi arge katke kuuma seadet millegagi kinni (nt katerati voi ridetikuja).
- Kasutage seadet ainult kuivaeld juustel. Arge kasutada seadet margade katega.

- Hoideke rullikut puhtana ning arge laske sellele tolmuj ja juuksehooldusvahendite nagu juuksevahaj, piserusvahendite ja peeli laike koguneda.
- Rullikut on pinnakate. See katke voib pika aja jooksul ara kuluda. Kulmine ei mojuta aga seadme juoldust.
- Kui seadet kasutada varitud juuste koostaimisega, siis voib rullik mooduda.
- Kontrollimiseks voi parandamiseks tuleb seade alati viia Philips volitatud hoolduskuskesse.

- Valjaopimata isiku poolt parandatud seade voib seadme kasutajat ohustada.
- Elektroloogi arhoidmiseks arge sissetaage avade vahelt seadet, kui seade on sisse lita.
- Elektroloogi arhoidmiseks arge sissetaage avade vahelt seadme metallelemene.

- Kui seadet kasutada varitud juuste koostaimisega, siis voib rullik mooduda.
- Kontrollimiseks voi parandamiseks tuleb seade alati viia Philips volitatud hoolduskuskesse.
- Valjaopimata isiku poolt parandatud seade voib seadme kasutajat ohustada.
- Elektroloogi arhoidmiseks arge sissetaage avade vahelt seadet, kui seade on sisse lita.
- Elektroloogi arhoidmiseks arge sissetaage avade vahelt seadme metallelemene.

- Kui seadet kasutada varitud juuste koostaimisega, siis voib rullik mooduda.
- Kontrollimiseks voi parandamiseks tuleb seade alati viia Philips volitatud hoolduskuskesse.
- Valjaopimata isiku poolt parandatud seade voib seadme kasutajat ohustada.
- Elektroloogi arhoidmiseks arge sissetaage avade vahelt seadet, kui seade on sisse lita.
- Elektroloogi arhoidmiseks arge sissetaage avade vahelt seadme metallelemene.

- Kui seadet kasutada varitud juuste koostaimisega, siis voib rullik mooduda.
- Kontrollimiseks voi parandamiseks tuleb seade alati viia Philips volitatud hoolduskuskesse.
- Valjaopimata isiku poolt parandatud seade voib seadme kasutajat ohustada.
- Elektroloogi arhoidmiseks arge sissetaage avade vahelt seadet, kui seade on sisse lita.
- Elektroloogi arhoidmiseks arge sissetaage avade vahelt seadme metallelemene.

- Kui seadet kasutada varitud juuste koostaimisega, siis voib rullik mooduda.
- Kontrollimiseks voi parandamiseks tuleb seade alati viia Philips volitatud hoolduskuskesse.
- Valjaopimata isiku poolt parandatud seade voib seadme kasutajat ohustada.
- Elektroloogi arhoidmiseks arge sissetaage avade vahelt seadet, kui seade on sisse lita.
- Elektroloogi arhoidmiseks arge sissetaage avade vahelt seadme metallelemene.

- Kui seadet kasutada varitud juuste koostaimisega, siis voib rullik mooduda.
- Kontrollimiseks voi parandamiseks tuleb seade alati viia Philips volitatud hoolduskuskesse.
- Valjaopimata isiku poolt parandatud seade voib seadme kasutajat ohustada.
- Elektroloogi arhoidmiseks arge sissetaage avade vahelt seadet, kui seade on sisse lita.
- Elektroloogi arhoidmiseks arge sissetaage avade vahelt seadme metallelemene.

- Kui seadet kasutada varitud juuste koostaimisega, siis voib rullik mooduda.
- Kontrollimiseks voi parandamiseks tuleb seade alati viia Philips volitatud hoolduskuskesse.
- Valjaopimata isiku poolt parandatud seade voib seadme kasutajat ohustada.
- Elektroloogi arhoidmiseks arge sissetaage avade vahelt seadet, kui seade on sisse lita.
- Elektroloogi arhoidmiseks arge sissetaage avade vahelt seadme metallelemene.

- Kui seadet kasutada varitud juuste koostaimisega, siis voib rullik mooduda.
- Kontrollimiseks voi parandamiseks tuleb seade alati viia Philips volitatud hoolduskuskesse.
- Valjaopimata isiku poolt parandatud seade voib seadme kasutajat ohustada.
- Elektroloogi arhoidmiseks arge sissetaage avade vahelt seadet, kui seade on sisse lita.
- Elektroloogi arhoidmiseks arge sissetaage avade vahelt seadme metallelemene.

- Kui seadet kasutada varitud juuste koostaimisega, siis voib rullik mooduda.
- Kontrollimiseks voi parandamiseks tuleb seade alati viia Philips volitatud hoolduskuskesse.
- Valjaopimata isiku poolt parandatud seade voib seadme kasutajat ohustada.
- Elektroloogi arhoidmiseks arge sissetaage avade vahelt seadet, kui seade on sisse lita.
- Elektroloogi arhoidmiseks arge sissetaage avade vahelt seadme metallelemene.

- Kui seadet kasutada varitud juuste koostaimisega, siis voib rullik mooduda.
- Kontrollimiseks voi parandamiseks tuleb seade alati viia Philips volitatud hoolduskuskesse.
- Valjaopimata isiku poolt parandatud seade voib seadme kasutajat ohustada.
- Elektroloogi arhoidmiseks arge sissetaage avade vahelt seadet, kui seade on sisse lita.
- Elektroloogi arhoidmiseks arge sissetaage avade vahelt seadme metallelemene.

- Kui seadet kasutada varitud juuste koostaimisega, siis voib rullik mooduda.
- Kontrollimiseks voi parandamiseks tuleb seade alati viia Philips volitatud hoolduskuskesse.
- Valjaopimata isiku poolt parandatud seade voib seadme kasutajat ohustada.
- Elektroloogi arhoidmiseks arge sissetaage avade vahelt seadet, kui seade on sisse lita.
- Elektroloogi arhoidmiseks arge sissetaage avade vahelt seadme metallelemene.

- Kui seadet kasutada varitud juuste koostaimisega, siis voib rullik mooduda.
- Kontrollimiseks voi parandamiseks tuleb seade alati viia Philips volitatud hoolduskuskesse.
- Valjaopimata isiku poolt parandatud seade voib seadme kasutajat ohustada.
- Elektroloogi arhoidmiseks arge sissetaage avade vahelt seadet, kui seade on sisse lita.
- Elektroloogi arhoidmiseks arge sissetaage avade vahelt seadme metallelemene.

- Kui seadet kasutada varitud juuste koostaimisega, siis voib rullik mooduda.
- Kontrollimiseks voi parandamiseks tuleb seade alati viia Philips volitatud hoolduskuskesse.
- Valjaopimata isiku poolt parandatud seade voib seadme kasutajat ohustada.
- Elektroloogi arhoidmiseks arge sissetaage avade vahelt seadet, kui seade on sisse lita.
- Elektroloogi arhoidmiseks arge sissetaage avade vahelt seadme metallelemene.

- Kui seadet kasutada varitud juuste koostaimisega, siis voib rullik mooduda.
- Kontrollimiseks voi parandamiseks tuleb seade alati viia Philips volitatud hoolduskuskesse.
- Valjaopimata isiku poolt parandatud seade voib seadme kasutajat ohustada.
- Elektroloogi arhoidmiseks arge sissetaage avade vahelt seadet, kui seade on sisse lita.
- Elektroloogi arhoidmiseks arge sissetaage avade vahelt seadme metallelemene.

- Kui seadet kasutada varitud juuste koostaimisega, siis voib rullik mooduda.
- Kontrollimiseks voi parandamiseks tuleb seade alati viia Philips volitatud hoolduskuskesse.
- Valjaopimata isiku poolt parandatud seade voib seadme kasutajat ohustada.
- Elektroloogi arhoidmiseks arge sissetaage avade vahelt seadet, kui seade on sisse lita.
- Elektroloogi arhoidmiseks arge sissetaage avade vahelt seadme metallelemene.

- Kui seadet kasutada varitud juuste koostaimisega, siis voib rullik mooduda.
- Kontrollimiseks voi parandamiseks tuleb seade alati viia Philips volitatud hoolduskuskesse.
- Valjaopimata isiku poolt parandatud seade voib seadme kasutajat ohustada.
- Elektroloogi arhoidmiseks arge sissetaage avade vahelt seadet, kui seade on sisse lita.
- Elektroloogi arhoidmiseks arge sissetaage avade vahelt seadme metallelemene.

- Kui seadet kasutada varitud juuste koostaimisega, siis voib rullik mooduda.
- Kontrollimiseks voi parandamiseks tuleb seade alati viia Philips volitatud hoolduskuskesse.
- Valjaopimata isiku poolt parandatud seade voib seadme kasutajat ohustada.
- Elektroloogi arhoidmiseks arge sissetaage avade vahelt seadet, kui seade on sisse lita.
- Elektroloogi arhoidmiseks arge sissetaage avade vahelt seadme metallelemene.

- Kui seadet kasutada varitud juuste koostaimisega, siis voib rullik mooduda.
- Kontrollimiseks voi parandamiseks tuleb seade alati viia Philips volitatud hoolduskuskesse.
- Valjaopimata isiku poolt parandatud seade voib seadme kasutajat ohustada.
- Elektroloogi arhoidmiseks arge sissetaage avade vahelt seadet, kui seade on sisse lita.
- Elektroloogi arhoidmiseks arge sissetaage avade vahelt seadme metallelemene.

- Kui seadet kasutada varitud juuste koostaimisega, siis voib rullik mooduda.
- Kontrollimiseks voi parandamiseks tuleb seade alati viia Philips volitatud hoolduskuskesse.
- Valjaopimata isiku poolt parandatud seade voib seadme kasutajat ohustada.
- Elektroloogi arhoidmiseks arge sissetaage avade vahelt seadet, kui seade on sisse lita.
- Elektroloogi arhoidmiseks arge sissetaage avade vahelt seadme metallelemene.

- Kui seadet kasutada varitud juuste koostaimisega, siis voib rullik mooduda.
- Kontrollimiseks voi parandamiseks tuleb seade alati viia Philips volitatud hoolduskuskesse.
- Valjaopimata isiku poolt parandatud seade voib seadme kasutajat ohustada.
- Elektroloogi arhoidmiseks arge sissetaage avade vahelt seadet, kui seade on sisse lita.
- Elektroloogi arhoidmiseks arge sissetaage avade vahelt seadme metallelemene.

- Kui seadet kasutada varitud juuste koostaimisega, siis voib rullik mooduda.
- Kontrollimiseks voi parandamiseks tuleb seade alati viia Philips volitatud hoolduskuskesse.
- Valjaopimata isiku poolt parandatud seade voib seadme kasutajat ohustada.
- Elektroloogi arhoidmiseks arge sissetaage avade vahelt seadet, kui seade on sisse lita.
- Elektroloogi arhoidmiseks arge sissetaage avade vahelt seadme metallelemene.

- Kui seadet kasutada varitud juuste koostaimisega, siis voib rullik mooduda.
- Kontrollimiseks voi parandamiseks tuleb seade alati viia Philips volitatud hoolduskuskesse.
- Valjaopimata isiku poolt parandatud seade voib seadme kasutajat ohustada.
- Elektroloogi arhoidmiseks arge sissetaage avade vahelt seadet, kui seade on sisse lita.
- Elektroloogi arhoidmiseks arge sissetaage avade vahelt seadme metallelemene.

- Kui seadet kasutada varitud juuste koostaimisega, siis voib rullik mooduda.
- Kontrollimiseks voi parandamiseks tuleb seade alati viia Philips volitatud hoolduskuskesse.
- Valjaopimata isiku poolt parandatud seade voib seadme kasutajat ohustada.
- Elektroloogi arhoidmiseks arge sissetaage avade vahelt seadet, kui seade on sisse lita.
- Elektroloogi arhoidmiseks arge sissetaage avade vahelt seadme metallelemene.

- Kui seadet kasutada varitud juuste koostaimisega, siis voib rullik mooduda.
- Kontrollimiseks

Ovaj dokument je originalno proizveden i objavljen od strane proizvođača, brenda Philips, i preuzet je sa njihove zvanične stranice. S obzirom na ovu činjenicu, Tehnoteka ističe da ne preuzima odgovornost za tačnost, celovitost ili pouzdanost informacija, podataka, mišljenja, saveta ili izjava sadržanih u ovom dokumentu.

Napominjemo da Tehnoteka nema ovlašćenje da izvrši bilo kakve izmene ili dopune na ovom dokumentu, stoga nismo odgovorni za eventualne greške, propuste ili netačnosti koje se mogu naći unutar njega. Tehnoteka ne odgovara za štetu nanесenu korisnicima pri upotrebi netačnih podataka. Ukoliko imate dodatna pitanja o proizvodu, ljubazno vas molimo da kontaktirate direktno proizvođača kako biste dobili sve detaljne informacije.

Za najnovije informacije o ceni, dostupnim akcijama i tehničkim karakteristikama proizvoda koji se pominje u ovom dokumentu, molimo posetite našu stranicu klikom na sledeći link:

<https://tehnoteka.rs/p/philips-stajler-za-kosu-bhb87200-akcija-cena/>