

Uputstvo za upotrebu (EN)

SENCOR prečišćivač vazduha SHA 8400WH-EUE3

SENCOR



Tehnoteka je online destinacija za upoređivanje cena i karakteristika bele tehnike, potrošačke elektronike i IT uređaja kod trgovinskih lanaca i internet prodavnica u Srbiji. Naša stranica vam omogućava da istražite najnovije informacije, detaljne karakteristike i konkurentne cene proizvoda.

Posetite nas i uživajte u ekskluzivnom iskustvu pametne kupovine klikom na link:

<https://tehnoteka.rs/p/sencor-preciscivac-vazduha-sha-8400wh-eue3-akcija-cena/>

Air Purifier

User's manual

EN



SENCOR[®]

SHA 8400WH

Translation of the original manual

Prior to using this appliance, please read the user's manual thoroughly, even in cases, when one has already familiarised themselves with previous use of similar types of appliances. Only use the appliance in the manner described in this user's manual. Keep this user's manual in a safe place where it can be easily retrieved for future use. We recommend saving the original cardboard box, packaging material, purchase receipt and responsibility statement of the vendor or warranty card for at least the duration of the legal liability for unsatisfactory performance or quality. In the event of transportation, we recommend that you pack the appliance in the original box from the manufacturer.

EN-1

TABLE OF CONTENTS

IMPORTANT SAFETY INSTRUCTIONS.....	3
DESCRIPTION OF THE AIR PURIFIER.....	5
DESCRIPTION OF THE CONTROL PANEL.....	6
HOW THE AIR PURIFIER WORKS.....	7
BEFORE FIRST USE.....	7
USING THE AIR PURIFIER.....	7
CLEANING AND MAINTENANCE.....	8
TROUBLESHOOTING.....	10
TECHNICAL SPECIFICATIONS.....	10
INSTRUCTIONS AND INFORMATION REGARDING THE DISPOSAL OF USED PACKAGING MATERIALS.....	11
DISPOSAL OF USED ELECTRICAL AND ELECTRONIC EQUIPMENT.....	11

IMPORTANT SAFETY INSTRUCTIONS READ CAREFULLY AND STORE FOR FUTURE USE.

- This appliance may be used by children 8 years of age and older and by persons with physical or mental impairments or by inexperienced persons, if they are properly supervised or have been informed about how to use the product in a safe manner and understand the potential dangers.
 - Children must not play with the appliance. Cleaning and maintenance performed by the user must not be performed by unsupervised children.
 - In the event that the power cord is damaged, have it repaired at a professional service centre to prevent causing a dangerous situation. It is forbidden to use the appliance if it has a damaged power cord.
 - Always adhere to the instructions contained in this user's manual when performing cleaning and maintenance tasks.
 - Before every cleaning or maintenance task, disconnect the appliance from the power socket.
 - This appliance is designed for use in commercial areas.
-
- The appliance is designed for use in households, offices and similar types of areas. Always install it on an even, dry, stable and firm surface. Do not install it on a soft surface such as for example a bed or sofa. Otherwise the appliance might be tipped over.
 - Do not use the appliance outdoors or subject it to the effects of the outdoor environment.
 - Do not place the appliance in the vicinity of an open flame, gas appliances or devices that are sources of heat and do not expose it to direct sunlight.

Air Purifier

SHA 8400WH

- Before connecting the appliance to a power socket, check that the technical details on its rating label match the electrical voltage in the socket.
- Place the power cord so that it is not tripped over, however, do not place it on carpet, furniture, etc.
- Do not use the appliance in areas where gas leaks or chemical fumes may be present.
- Do not use the appliance with other auxiliary equipment for regulating the speed of the fan.
- Before connecting this appliance to a power socket and putting into operation, ensure that it is correctly assembled.
- Do not place any items on to the appliance and do not cover it when it is running. Do not insert any items into the air inlets or outlets and make sure that they are not blocked.
- Always turn off the appliance and disconnect it from the power socket, when not using it, before removing the front panel, replacing the filters, cleaning or moving it.
- The appliance is equipped with a safety mechanism that will automatically turn off the appliance when the cover is removed from the main unit.
- Use the integrated handle located in the rear part of the appliance for carrying.
- To avoid potential injury by electrical shock, do not submerge the appliance in water or any other liquid.
- Do not disconnect the appliance from the power socket by pulling on the power cord. This could damage the power cord or the power socket. Disconnect the cord from the power socket by gently pulling on the plug of the power cord.
- Do not use the appliance if it is not working correctly, if it has been damaged or has been submerged in water. To avoid the danger of injury by electrical shock, do not repair the appliance yourself or make any adjustments to it. This appliance does not include any parts, which users can repair themselves. Have all repairs or adjustments of the appliance performed at an authorised service centre. By tampering with the appliance you risk voiding your legal rights arising from unsatisfactory performance or quality warranty.

Air Purifier

SHA 8400WH

EN

DESCRIPTION OF THE AIR PURIFIER

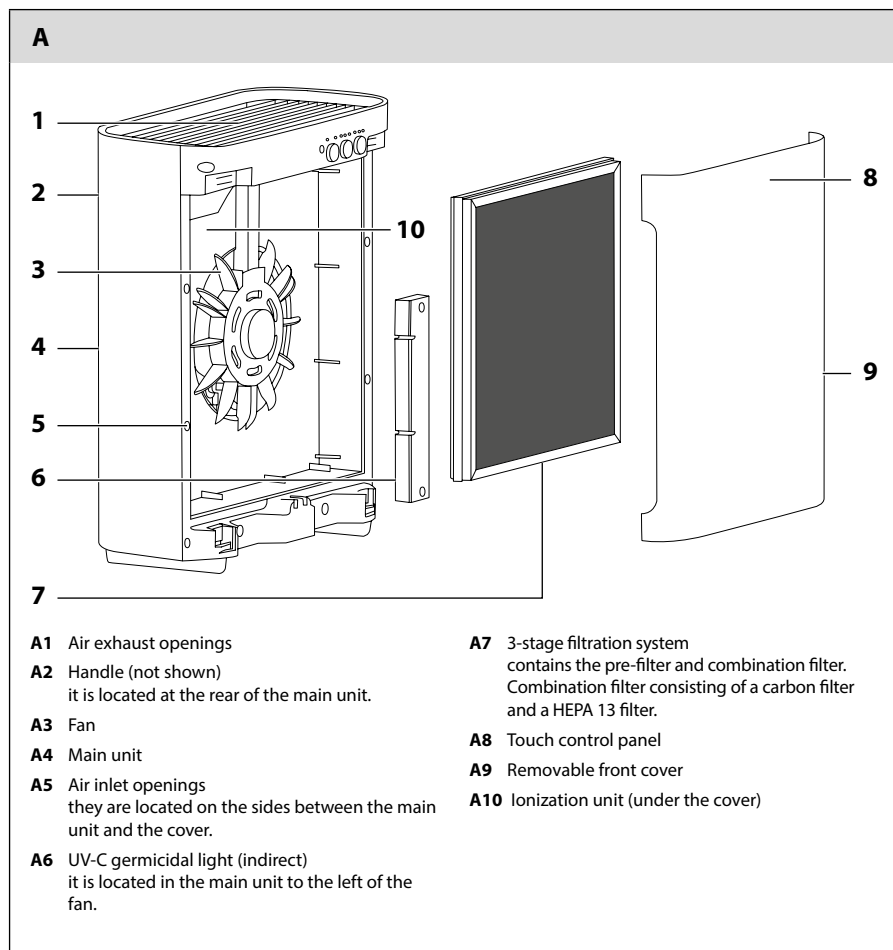

A1 Air exhaust openings

A2 Handle (not shown)
it is located at the rear of the main unit.

A3 Fan

A4 Main unit

A5 Air inlet openings
they are located on the sides between the main unit and the cover.

A6 UV-C germicidal light (indirect)
it is located in the main unit to the left of the fan.

A7 3-stage filtration system
contains the pre-filter and combination filter.
Combination filter consisting of a carbon filter and a HEPA 13 filter.

A8 Touch control panel

A9 Removable front cover

A10 Ionization unit (under the cover)

DESCRIPTION OF THE CONTROL PANEL

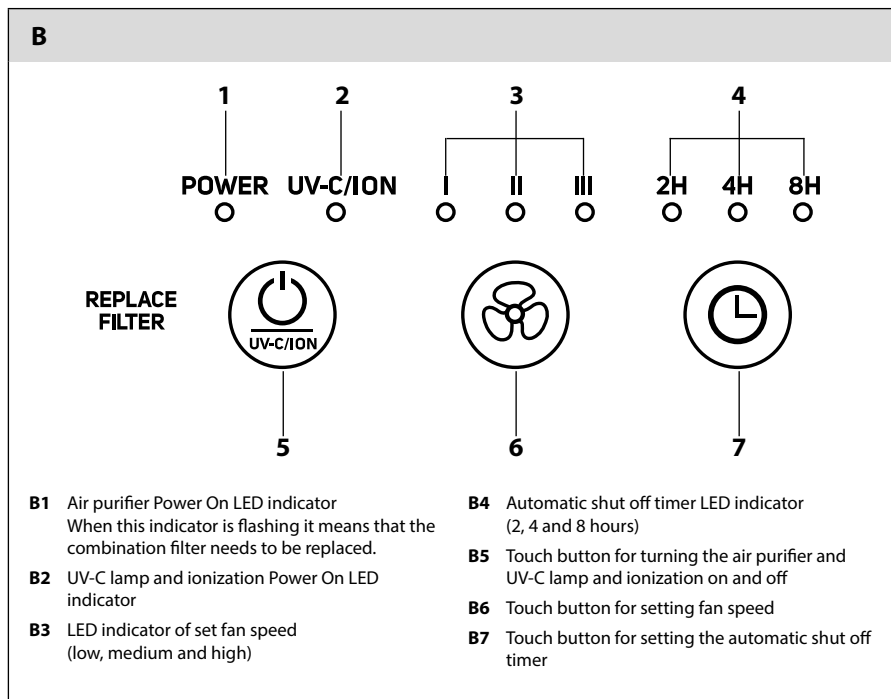

HOW THE AIR PURIFIER WORKS

- This elegant air purifier offers an effective solution to improving air quality in your indoor area. It is equipped with a 3-stage filtration system, a UV-C germicidal lamp and an ionizer. The pre-filter captures initial dust and allergen particles. The activated carbon filter absorbs odours and harmful gasses such as, for example, formaldehyde, benzene, etc. The HEPA filter captures dust particles, smoke, pollen and other allergens. The integrated UV-C germicidal lamp destroys micro-organisms such as germs, viruses, bacteria and fungi (such as mold toxins). The ionizer emits negative ions, refreshes air and supports clustering and deposition of dust particles and other undesirable objects. A LED indicator will inform you when the filters need to be replaced. The air purification speed can be controlled at three levels and the timer function enables the purifier to be shut off automatically.

BEFORE FIRST USE

- Before first use, take the purifier and its accessories out of the packaging material. Remove the front cover **A9**. From the main unit **A4** remove the frame with the filters **A7**. The frame has holders on both sides for easier removal. Take the frame with the filters **A7** out of the plastic bag and then install it back in its place. Reattach the cover **A9** to the main unit **A4**.



Note:

The frame with the filters **A7** must be located inside the main unit **A4** so that the HEPA filter points backwards towards the fan **A3** and the pre-filter forwards towards the front cover **A9**. You can identify the pre-filter by its black colour and by the fact that it is attached to the frame with the combination filter using a velcro zip and it can be removed. The combination filter (activated carbon filter and HEPA filter) cannot be removed from the frame. The holders located on the sides of the frame point outwards from the main unit **A4** towards the front cover **A9**.

USING THE AIR PURIFIER

- Place the purifier on a stable, even, dry and firm surface within reach of a power socket. To ensure correct air circulation, the appliance should be at least 30 cm away from walls and furniture.
- Check that the purifier is properly assembled, that the filters **A7** are correctly inserted inside and that the inlets and outlets **A5** or **A1** are not blocked. Connect the power cord to a power socket.

1. Turning the purifier and UV-C lamp / ionizer on and off

- 1.1 Button **B5** serves to turn the air purifier and the UV-C lamp and ionizer **A6** on and off.
- 1.2 Press the button **B5** once to turn on the air purifier. THE LED indicator **B1** will be lit. The UV-C lamp **A6** is turned off. THE LED indicator **B2** is off.
- 1.3 Press button **B5** again to turn on the UV-C lamp and the ionizer **A6**. The purifier and the UV-C lamp **A6** are running. LED indicators **B1** and **B2** are lit.
- 1.4 Press button **B5** a third time to turn the UV-C lamp and the ionizer off. LED indicator **B2** will turn off.
- 1.5 Press button **B5** a fourth time to turn the purifier with off. All the LED indicators will be off.

2. Setting fan speed

- 2.1 When the air purifier is running, use button **B6** to set the fan speed.
- 2.2 The speed can be set at three levels I, II and III (low, medium and high speed). Each time the button **B6** is pressed, the fan speed changes as follows: low → medium → high. The set fan speed is signalled by the respective LED indicator **B3** being lit.

3. Setting the automatic shut-off timer

- 3.1 Button **B7** serves to set the time interval of 2, 4 or 8 hours, after which the air purifier will automatically turn itself off.
- 3.2 To set the automatic shut off time, repeatedly press button **B7** until the respective indicator **B4** lights up. After the set time has elapsed, the purifier will turn itself off automatically.
- 3.3 When the air purifier is running, to cancel the set automatic shut off time repeatedly press button **B7** until no indicator **B4** is lit.

CLEANING AND MAINTENANCE

1. Cleaning the outer surface

- Before cleaning the purifier, turn it off and disconnect it from the power socket.
- Clean the outer surface as required using a cloth lightly dampened in lukewarm water. Then wipe everything so that it is thoroughly dry.
- For cleaning, do not use abrasive cleaning products and solvents as this could damage the surface of the appliance. Do not submerge the purifier in water or in any other liquid.

2. Cleaning and replacement of filters

- Please adhere to the following instructions relating to the cleaning and replacement of filters. Otherwise the efficiency of the purifier may be negatively affected.
- Clean the pre-filter and activated carbon filter once a month or more frequently depending on the degree of soiling.
- Make sure that the purifier is turned off and disconnected from the power socket. Tilt open the front cover **A9** and remove it from the main unit **A4**.

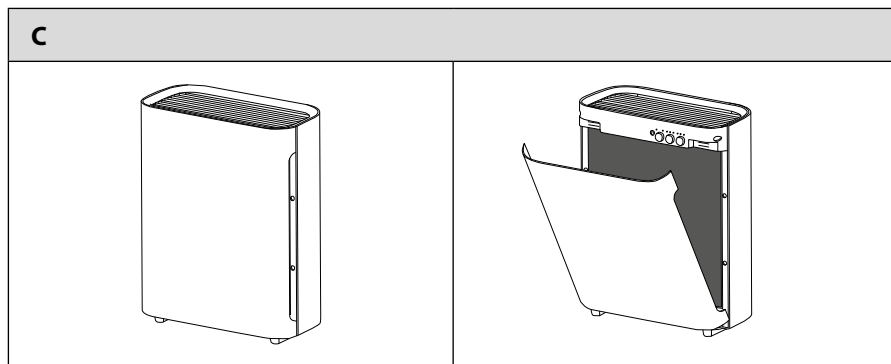

- From the main unit **A4** remove the frame with the filters **A7**. The frame has holders on both sides for easier removal.

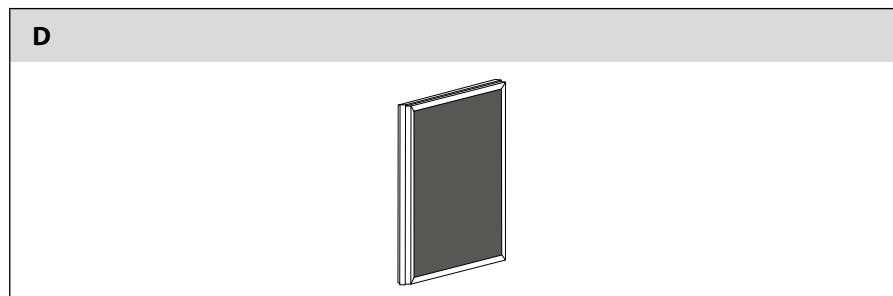

- Use a vacuum cleaner with an attached upholstery brush nozzle to remove the dirt from the pre-filter and activated carbon filter. The pre-filter is attached to the frame with the combination filter with a velcro zip. Remove the pre-filter from the frame and vacuum out the activated carbon filter located underneath it. When cleaning, proceed with care so as not to damage any of the filters.
- In the event of significant soiling of the pre-filter, wash it in lukewarm warm water. Then allow it to dry naturally.



Attention:

The activated carbon filter and HEPA filter are not washable.

- After cleaning, reinstall the pre-filter into the frame. Before reattaching the pre-filter into the frame, make sure that it is completely dry. Reinstall the frame with the filters **A7** into the main unit **A4** and close the cover **A9**. When inserting the filters, make sure that the HEPA filter points backwards towards the fan **A3** and the pre-filter forwards towards the front cover **A9**. The holders located on the sides of the frame point outwards from the main unit **A4** towards the front cover **A9**.
- A flashing LED indicator **B1** will inform you when the filters **A7** need to be replaced. The lifetime of the filters **A7** is approximately 6 months during standard use. You can purchase new filters from your vendor. Usually it is necessary to only replace the frame with the activated carbon filter and HEPA filter and to reattach the exiting pre-filter to it. Nevertheless, in the event that the pre-filter shows signs of wear, replace it also.
- After replacing the filters, it is necessary to restart the purifier. Connect the power cord to a power socket. Turn on the purifier and then press button **B5** and hold it down for approximately 5 seconds. This will restart the purifier and LED indicator **B1** will stop flashing.

TROUBLESHOOTING

Problem	Solution
Insufficient air flow	Check whether the filters A7 are dirty.
	Make sure that the air inlet and outlet openings A5 or A1 are not blocked.
The purifier will not start when turned on.	Check that the purifier is connected to a working power socket.
	Check that the front cover A9 is properly attached to the main unit A4 .
A excessively loud noise is made during operation.	Check that there are no foreign items in the area where the fan A3 is located.
	Filters A7 are not properly installed in their place.
	Filters A7 may be very dirty and may need to be replaced for new ones.
	The purifier is not located on an even and stable surface.

TECHNICAL SPECIFICATIONS

Rated voltage range	220–240 V
Rated frequency	50/60 Hz
Rated power	55 W
Electrical shock protection class	II
Noise level	w30/40/55 dB(A)
Air flow rate	34/84/178 m ³ /h
Lifetime of UV-C lamp	approximately 20 000 hours
UV-C radiation wave length	254 nm
Anion production	DC 12V ≥ 3×1 000 000 PCS/cm ³
Recommended room area	20–25 m ²

The declared noise emission level of the appliance is 30/40/55 dB(A), which represents a level A of acoustic power with respect to a reference acoustic power of 1 pW.

Explanation of technical terminology

Safety class for electrical shock protection:

Class II – Electrical shock protection is provided by double or heavy-duty insulation.

We reserve the right to change text and technical specifications.

INSTRUCTIONS AND INFORMATION REGARDING THE DISPOSAL OF USED PACKAGING MATERIALS

Dispose of used packaging material at a site designated for waste in your municipality.

DISPOSAL OF USED ELECTRICAL AND ELECTRONIC EQUIPMENT



This symbol on products or original documents means that used electric or electronic products must not be added to ordinary municipal waste. For proper disposal, renewal and recycling hand over these appliances to determined collection points. Alternatively, in some European Union states or other European countries you may return your appliances to the local retailer when buying an equivalent new appliance.

Correct disposal of this product helps save valuable natural resources and prevents potential negative effects on the environment and human health, which could result from improper waste disposal. Ask your local authorities or collection facility for more details.

In accordance with national regulations penalties may be imposed for the incorrect disposal of this type of waste.

For business entities in European Union states

If you want to dispose of electric or electronic appliances, ask your retailer or supplier for the necessary information.

Disposal in other countries outside the European Union.

This symbol is valid in the European Union. If you wish to dispose of this product, request the necessary information about the correct disposal method from the local council or from your vendor



This appliance meets all the basic requirements of EU directives related to it.

Air Purifier

SHA 8400WH

Ovaj dokument je originalno proizveden i objavljen od strane proizvođača, brenda Sencor, i preuzet je sa njihove zvanične stranice. S obzirom na ovu činjenicu, Tehnoteka ističe da ne preuzima odgovornost za tačnost, celovitost ili pouzdanost informacija, podataka, mišljenja, saveta ili izjava sadržanih u ovom dokumentu.

Napominjemo da Tehnoteka nema ovlašćenje da izvrši bilo kakve izmene ili dopune na ovom dokumentu, stoga nismo odgovorni za eventualne greške, propuste ili netačnosti koje se mogu naći unutar njega. Tehnoteka ne odgovara za štetu nanесenu korisnicima pri upotrebi netačnih podataka. Ukoliko imate dodatna pitanja o proizvodu, ljubazno vas molimo da kontaktirate direktno proizvođača kako biste dobili sve detaljne informacije.

Za najnovije informacije o ceni, dostupnim akcijama i tehničkim karakteristikama proizvoda koji se pominje u ovom dokumentu, molimo posetite našu stranicu klikom na sledeći link:

<https://tehnoteka.rs/p/sencor-preciscivac-vazduha-sha-8400wh-eue3-akcija-cena/>